



(11) **EP 2 774 501 A1**

(12) **EUROPEAN PATENT APPLICATION**

(43) Date of publication:
10.09.2014 Bulletin 2014/37

(51) Int Cl.:
A43B 1/00 (2006.01) **A43B 13/00 (2006.01)**
A43B 3/00 (2006.01) **F21V 7/00 (2006.01)**

(21) Application number: **13159986.2**

(22) Date of filing: **19.03.2013**

(84) Designated Contracting States:
AL AT BE BG CH CY CZ DE DK EE ES FI FR GB GR HR HU IE IS IT LI LT LU LV MC MK MT NL NO PL PT RO RS SE SI SK SM TR
Designated Extension States:
BA ME

(72) Inventor: **Chou, Szu-Chi**
Taichung City 403 (TW)

(30) Priority: **04.03.2013 TW 102203932**

(74) Representative: **Straus, Alexander**
Patentanwälte
Becker, Kurig, Straus
Bavariastrasse 7
80336 München (DE)

(71) Applicant: **Chou, Szu-Chi**
Taichung City 403 (TW)

(54) **Illuminous sole**

(57) An illuminous sole (10) is configured with a sole body (20) and electronic device (30). The sole body (20) defines a compartment (25) and a transparent portion (26) surrounding the compartment (25). The transparent portion (26) has an external side (262) and an internal side (264) which having a plurality of reflecting surfaces (264b). The electronic device (30) is arranged within the compartment (25) and includes at least a first light-emitting device (34). Portion of the light beam projected from the first light emitting device (34) is directed outward from the outer side of the transparent portion (26) after the portion of light beam is redirected by the reflecting surfaces (264b). By this arrangement, the light beam from the first light-emitting device (34) is redirected and broadened to cover wider scope and range. In addition, interweaving of the light beams creates more brighter and colorful effect.

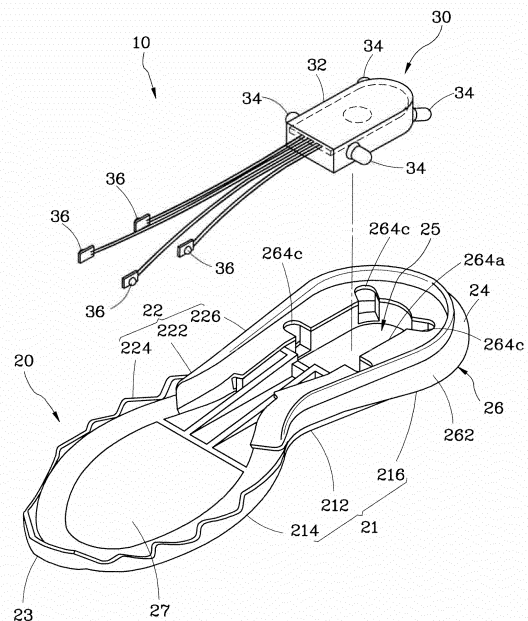

FIG. 1

EP 2 774 501 A1

Description

BACKGROUND OF THE INVENTION

[0001] 1. Technical Field

[0002] The present invention relates to a sole, and more particularly to an illuminous sole with bright, colorful, homogeneous and excellent illumination effect to cover a certain scope and range.

[0003] 2. Description of Related Art

[0004] There is a variety of footwear with illuminated sole available in the market. The light beam projected from the sole serves a purpose for giving both illumination as well as courtesy to observer during night or in dark environment. In addition, the illuminated sole can also provide a dramatic effect for certain performing art. Taiwanese Utility Patent No. M408,261(US2012/0192462) discloses a footwear with a transparent sole in which a plurality of light sources are arranged so as to provide an illumination effect.

[0005] However, the estate of the sole has its inherited limitation, and the light beam is projected directly from inside of the sole, consequently, the scope and range of illumination is also limited. In order to increase the range and scope of illumination, the power of the light source has to be increased, or the number of the light source has to be increased. Nevertheless, the energy consumption will also be increased inevitably.

SUMMARY OF THE INVENTION

[0006] In view of the foregoing, it is an objective of the present invention to provide an illuminous sole featured with bright, colorful, homogeneous and excellent illumination effect to cover a certain scope and range, while without increasing the quantity of light emitting devices as well as power consumption.

[0007] An illuminous sole is configured with a sole body and electronic device. The sole body defines a compartment and a transparent portion surrounding the compartment. The transparent portion has an external side and an internal side which having a plurality of reflecting surfaces. The electronic device is arranged within the compartment and includes at least a first light-emitting device. Portion of the light beam projected from the first light emitting device is directed outward from the outer side of the transparent portion after the portion of light beam is redirected by the reflecting surfaces.

[0008] By this arrangement, the light beam from the first light-emitting device will be redirected by the reflecting surfaces instead directly projecting outward in a straightforward manner. As a result, a wider range and scope of illumination can be reached. In addition, the light beams from the first emitting device will interweave with each other so as to make it brighter. A bright, colorful, homogeneous and excellent illumination effect to cover a certain scope and range can be reached while without increasing the quantity of light emitting devices as well

as power consumption.

[0009] In order to give a better and thorough understanding to the whole and other intended purposes, features and advantages of the technical solution of the illuminous sole made in accordance with the present invention, detailed description will be given with respect to preferred embodiments provided and illustrated herebelow in accompanied drawings. Apparently, with the spirit of the embodiments disclosed, person in the skilled in the art can readily come out with other modifications as well as improvements without undue experiment. It should be noted that the embodiments disclosed and illustrated herewith are all by way of elaboration instead of imposing any limitations to the appended claims.

BRIEF DESCRIPTION OF DRAWINGS

[0010] Figure 1 is a perspective and exploded view of an illuminous sole made in accordance with the present invention;

[0011] Figure 2 is a perspective and exploded view of a sole body of the illuminous sole made in accordance with the present invention;

[0012] Figure 3 is a cross-sectional view of a transparent portion of the illuminous sole made in accordance with the present invention;

[0013] Figure 4 is a top view of the illuminous sole made in accordance with the present invention;

[0014] Figure 5 is a cross-sectional view taken along line 5-5 of Figure 4; and

[0015] Figure 6 is a side elevation view of the illuminous sole made in accordance with the present invention, in which the actual implementation is depicted.

DETAILED DESCRIPTION OF PREFERRED EMBODIMENTS

[0016] Referring to Figure 1, an illuminous sole 10 made in accordance with the present invention includes a sole body 20, and an electronic device 30.

[0017] The sole body 20 includes a left side 21, a right side 22, a front portion 23 and a rear portion 24. A left recess 212 pointing toward the right side 22 is defined on the left side 21, and a front-left portion 214 is arranged between the left recess 212 and the front portion 23. A rear-left portion 216 is arranged between the left recess 212 and the rear portion 24. A right recess 222 pointing toward the left side 21 is defined on the right side 22, and a front-right portion 224 is arranged between the right recess 222 and the front portion 23. A rear-right portion 226 is arranged between the right recess 222 and the rear portion 24.

[0018] The sole body 20 defines a compartment 25 located between the rear-left portion 216 and the rear-right portion 226, and includes a transparent portion 26 surrounding the compartment 25. As shown in Figure 2, in the current embodiment, the sole body 20 includes an opaque bottom 27, and the transparent portion 26 is

made from transparent plastic material, and then attached to the opaque bottom 27 by means of glue or the equivalent. It should be readily appreciated that the sole body 20 can also be integrally formed with a transparent material.

[0019] Referring further to Figures 1, and 3~5, the transparent portion 26 has an external side 262 and an internal side 264. The internal side 264 includes an inner edge 264a, and a plurality of reflecting surfaces 264b located between the inner edge 264a and the external side 262. The transparent portion 26 further defines four cells 264c extending from the inner edge 264a toward the external side 262. The reflecting surfaces 264b are adjoining with each other, and extending from the rear-left side 216 to the rear portion 24 and the rear-right side 226 of the sole body 20. Every two adjacent reflecting surfaces 264b jointly defines an obtuse angle θ .

[0020] Referring to Figures 1 and 4, the electronic device 30 includes a box 32 with a battery and a controlling circuit (not disclosed in Figures) installed therein. The electronic device 30 includes four first light emitting devices 34 extending out of the box 32. The electronic device 30 further includes four second light emitting devices 36 terminated to electrical wires extending out of the box 32. The box 32 is securely disposed within the compartment 25 located in the inner edge 264a of the transparent portion 26 of the sole body 20. The plurality of first light emitting devices 34 are securely disposed within the corresponding cells 264c, and therefore properly disposed in the rear-left side 216, the rear-right side 226, and the rear portion 24 of the sole body 20. As shown in Figures 4 and 6, the second light emitting devices 36 are disposed in the front-left side 214 and the front-right side 224 of the sole body 20.

[0021] When the electronic device 30 is powered on, the first and second light emitting devices 34, 36 will start to emit lights from illuminous sole 10's different positions. According to preferred embodiments, the first and second light emitting devices 34, 36 can be implemented with LED (light emitting diode) of different colors, such as red, green, blue and white. With this arrangement, a colorful visual effect can be reached.

[0022] Most importantly, since the internal side 264 of the transparent portion 26 of the sole body 20 is defined with reflecting surfaces 264b, and the light beam from the first light-emitting device 34 will be redirected by the reflecting surfaces 264b firstly, and then emits out of the transparent portion 26 through the external side 262. As compared to the direct or straightforward projection, the reflected or redirected light beam of the first light emitting device 34 will create a wider range of illumination after reflection. In addition, the light beams from the first and second light emitting devices 34 and 36 will intertwined with each other so as to create a brighter illumination effect after the directions of light beams are changed, i. e. without increasing the quantity of the first and second light emitting devices 34 and 36 as well as the power consumption, a brighter range and scope of illumination

of the illuminous sole 10 can be reached.

[0023] It should be noted that the compartment 25, the transparent portion 26, and the first light emitting device 34 of the illuminous sole 10 are arranged adjacent to a heel of a user. However, this implementation should not be construed as a limitation, but an illustration, i.e. that they can be arranged in any suitable position of the luminous sole 10. In addition, the quantity and style of the first and second light emitting devices 34 and 36 can also be modified according to actual requirements. Since the transparent portion 26 is defined with the reflecting surfaces 264b with which the light beam from the first emitting device 34 can be redirected, and the installation of the second light-emitting device 36 can be also omitted.

[0024] Embodiments of the present invention have been described, but not intending to impose any unduly constraint to the appended claims. Any modification of equivalent structure or equivalent process made according to the disclosure and drawings of the present invention, or any application thereof, directly or indirectly, to other related fields of technique, is considered encompassed in the scope of protection defined by the claims of the present invention.

Claims

1. An illuminous sole (10), comprising:
 - a sole body (20) defining a compartment (25) and a transparent portion (26) surrounding the compartment (25), the transparent portion (26) having an external side (262) and an internal side (264) which having a plurality of reflecting surfaces (264b); and
 - an electronic device (30) arranged within the compartment (25) and including at least a first light emitting device (34), portion of light beam projected from the first light emitting device (34) being projected outward from the outer side of the transparent portion (26) after the portion of light beam is redirected by the reflecting surfaces (264b).
2. The illuminous sole (10) as recited in claim 1, wherein the reflecting surfaces (264b) are adjoining with each other and creating an obtuse angle (θ) therebetween.
3. The illuminous sole (10) as recited in claim 1, wherein the sole body (20) includes a left side (21), a right side (22), a front portion (23) and a rear portion (24); a left recess (212) pointing toward the right side (22) being defined on the left side (21), a front-left portion (214) arranged between the left recess (212) and the front portion (23), and a rear-left portion (216) arranged between the left recess (212) and the rear portion (24); a right recess (222) pointing toward the

- left side (21) being defined on the right side (22), a front-right portion (224) arranged between the right recess (222) and the front portion (23), and a rear-right portion (226) arranged between the right recess (222) and the rear portion (24); wherein the reflecting surfaces (264b) are arranged on the rear-left portion (216), the rear-right portion (226), and the rear portion (24).
4. The illuminous sole (10) as recited in claim 3, wherein the first light-emitting device (34) of the electronic device (30) is arranged on the rear-left portion (216), the rear-right portion (226), and the rear portion (24).
5. The illuminous sole (10) as recited in claim 1, wherein the transparent portion (26) of the sole body (20) includes an inner edge (264a) in which at least a cell (264c) is defined and pointing toward the external side (262), wherein in the first light emitting device (34) of the electronic device (30) is arranged within the cell (264c) of the transparent portion (26).
6. The illuminous sole (10) as recited in claim 5, wherein the electronic device (30) includes a box (32) attached to the inner edge (264a) of the transparent portion (26) of the sole body (20), and the first light-emitting device (34) of the electronic device (30) is arranged out of the box (32).
7. The illuminous sole (10) as recited in claim 5, wherein the sole body (20) includes a left side (21), a right side (22), a front portion (23) and a rear portion (24); a left recess (212) pointing toward the right side (22) being defined on the left side (21), a front-left portion (214) arranged between the left recess (212) and the front portion (23), and a rear-left portion (216) arranged between the left recess (212) and the rear portion (24); a right recess (222) pointing toward the left side (21) being defined on the right side (22), a front-right portion (224) arranged between the right recess (222) and the front portion (23), and a rear-right portion (226) arranged between the right recess (222) and the rear portion (24); wherein the reflecting surfaces (264b) are arranged on the rear-left portion (216), the rear-right portion (226), and the rear portion (24).
8. The illuminous sole (10) as recited in claim 7, wherein the first light-emitting device (34) of the electronic device (30) is arranged on the rear-left portion (216), the rear-right portion (226), and the rear portion (24).
9. The illuminous sole (10) as recited in claim 8, wherein the electronic device (30) includes a box (32) attached to the inner edge (264a) of the transparent portion (26) of the sole body (20), and a plurality of first light emitting devices (34) extending out of the box (32), a plurality of cells (264c) defined within the transparent portion (26), and the plurality of first light emitting devices (34) being each arranged within the corresponding cell (264c) of the transparent portion (26).
10. The illuminous sole (10) as recited in claim 9, wherein the reflecting surfaces (264b) are adjoining with each other and creating an obtuse angle (θ) therebetween.
11. The illuminous sole (10) as recited in claim 3, wherein the electronic device (30) further includes a plurality of second light emitting devices (36) arranged on the front-left portion (214) and the front-right portion (224) of the sole body (20), respectively.
12. The illuminous sole (10) as recited in claim 1, wherein the sole body (20) includes a left side (21), a right side (22), a front portion (23) and a rear portion (24); a left recess (212) pointing toward the right side (22) being defined on the left side (21), a front-left portion (214) arranged between the left recess (212) and the front portion (23), and a rear-left portion (216) arranged between the left recess (212) and the rear portion (24); a right recess (222) pointing toward the left side (21) being defined on the right side (22), a front-right portion (224) arranged between the right recess (222) and the front portion (23), and a rear-right portion (226) arranged between the right recess (222) and the rear portion (24); wherein the electronic device (30) further includes a plurality of second light emitting devices (36) arranged in the front-left portion (214) and the front-right portion (224), respectively.
13. The illuminous sole (10) as recited in claim 2, wherein the sole body (20) includes a left side (21), a right side (22), a front portion (23) and a rear portion (24); a left recess (212) pointing toward the right side (22) being defined on the left side (21), a front-left portion (214) arranged between the left recess (212) and the front portion (23), and a rear-left portion (216) arranged between the left recess (212) and the rear portion (24); a right recess (222) pointing toward the left side (21) being defined on the right side (22), a front-right portion (224) arranged between the right recess (222) and the front portion (23), and a rear-right portion (226) arranged between the right recess (222) and the rear portion (24); wherein the electronic device (30) further includes a plurality of second light emitting devices (36) arranged in the front-left portion (214) and the front-right portion (224), respectively.
14. The illuminous sole (10) as recited in claim 5, wherein the sole body (20) includes a left side (21), a right side (22), a front portion (23) and a rear portion (24); a left recess (212) pointing toward the right side (22)

being defined on the left side (21), a front-left portion (214) arranged between the left recess (212) and the front portion (23), and a rear-left portion (216) arranged between the left recess (212) and the rear portion (24); a right recess (222) pointing toward the left side (21) being defined on the right side (22), a front-right portion (224) arranged between the right recess (222) and the front portion (23), and a rear-right portion (226) arranged between the right recess (222) and the rear portion (24); wherein the electronic device (30) further includes a plurality of second light emitting devices (36) arranged in the front-left portion (214) and the front-right portion (224), respectively.

5

10

15

- 15. The illuminous sole (10) as recited in claim 6, wherein the sole body (20) includes a left side (21), a right side (22), a front portion (23) and a rear portion (24); a left recess (212) pointing toward the right side (22) being defined on the left side (21), a front-left portion (214) arranged between the left recess (212) and the front portion (23), and a rear-left portion (216) arranged between the left recess (212) and the rear portion (24); a right recess (222) pointing toward the left side (21) being defined on the right side (22), a front-right portion (224) arranged between the right recess (222) and the front portion (23), and a rear-right portion (226) arranged between the right recess (222) and the rear portion (24); wherein the electronic device (30) further includes a plurality of second light emitting devices (36) arranged in the front-left portion (214) and the front-right portion (224), respectively.

20

25

30

35

40

45

50

55

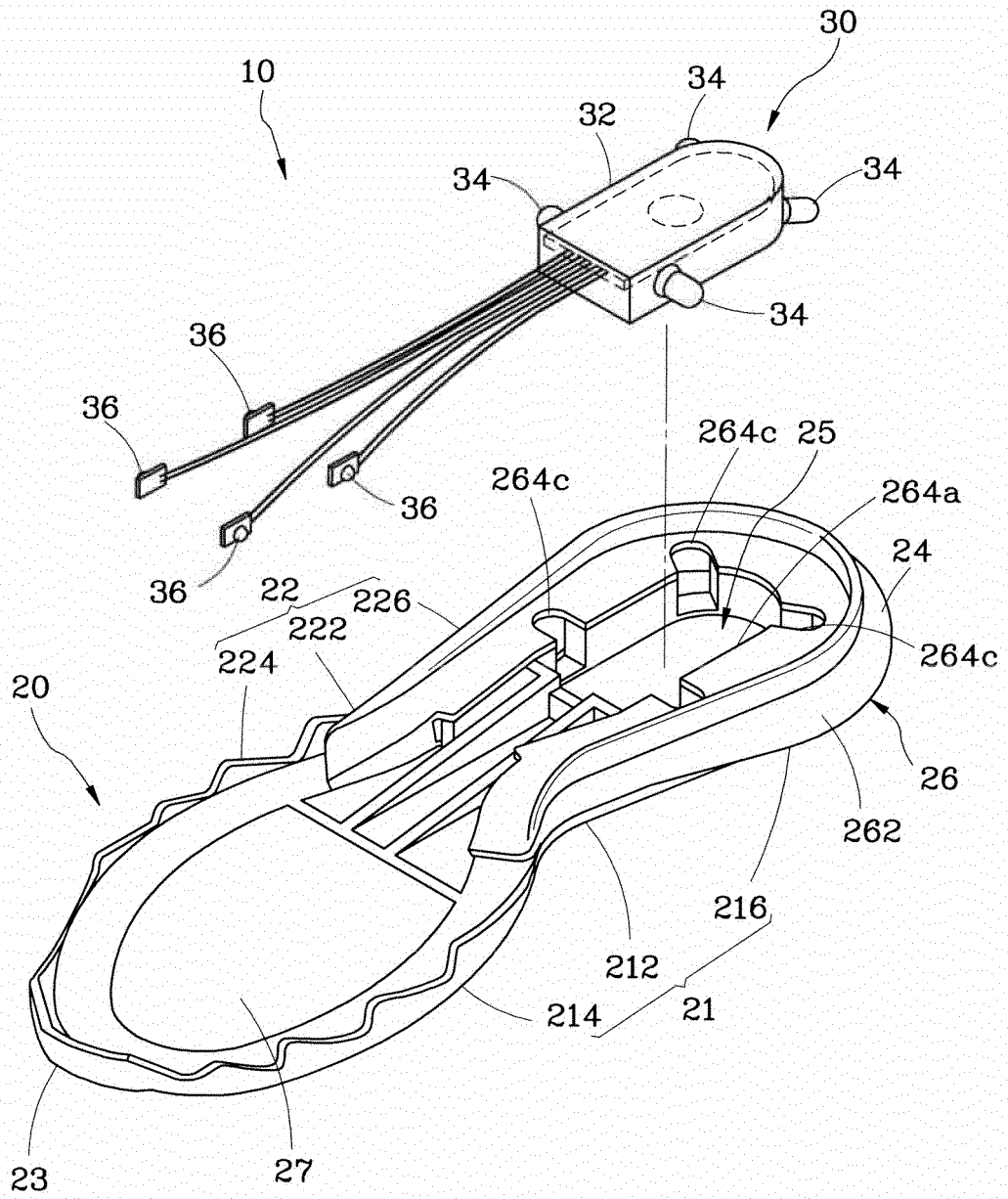

FIG. 1

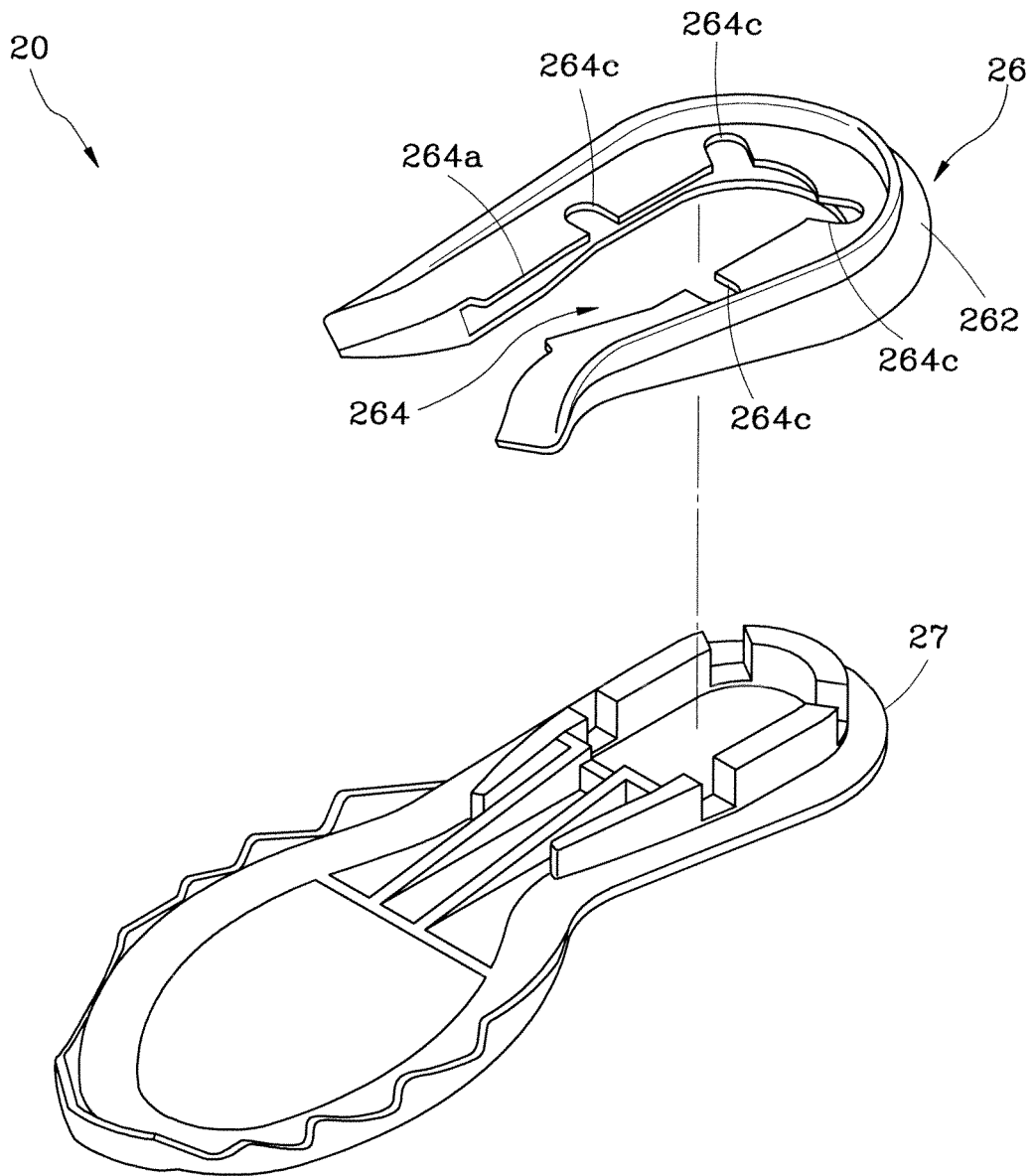

FIG. 2

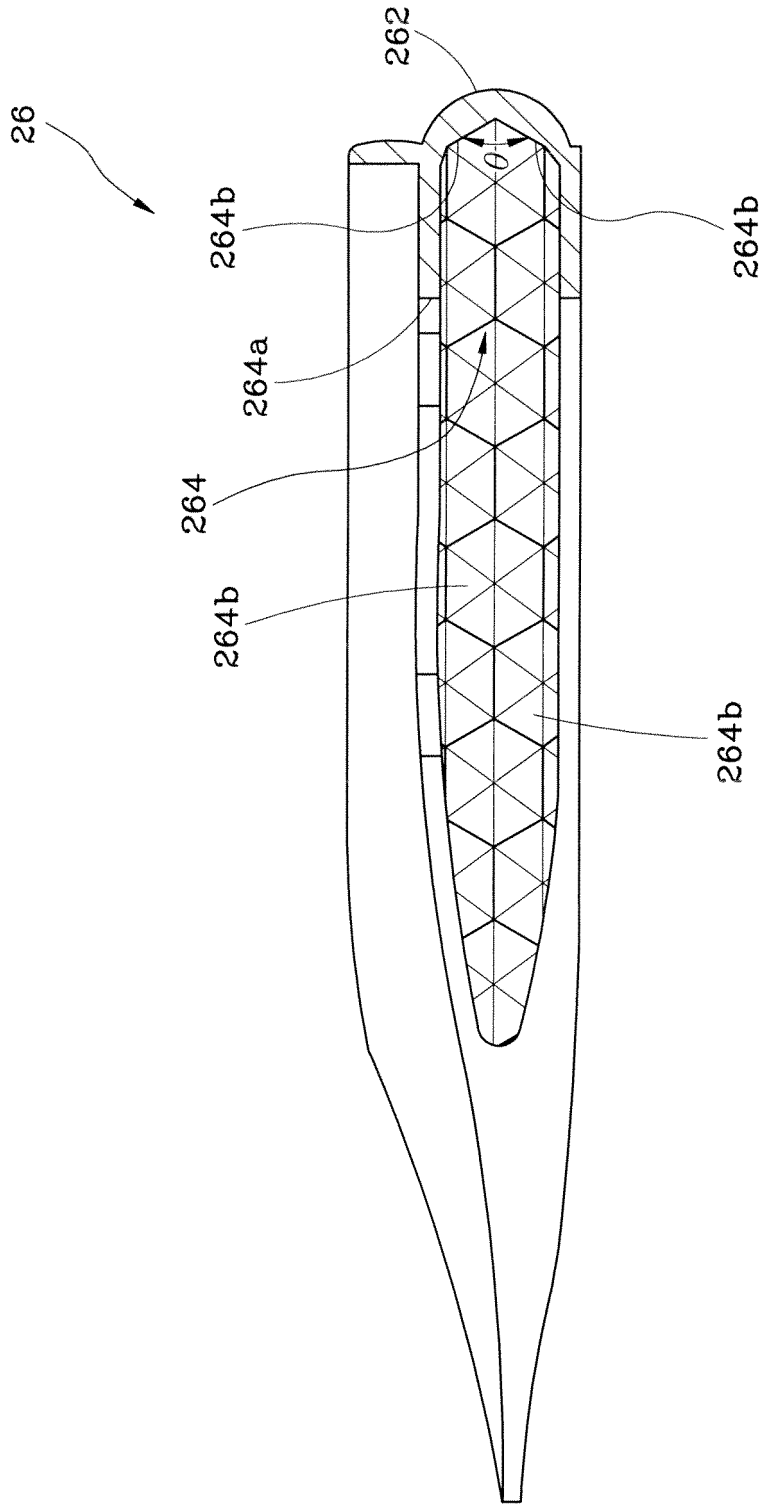

FIG. 3

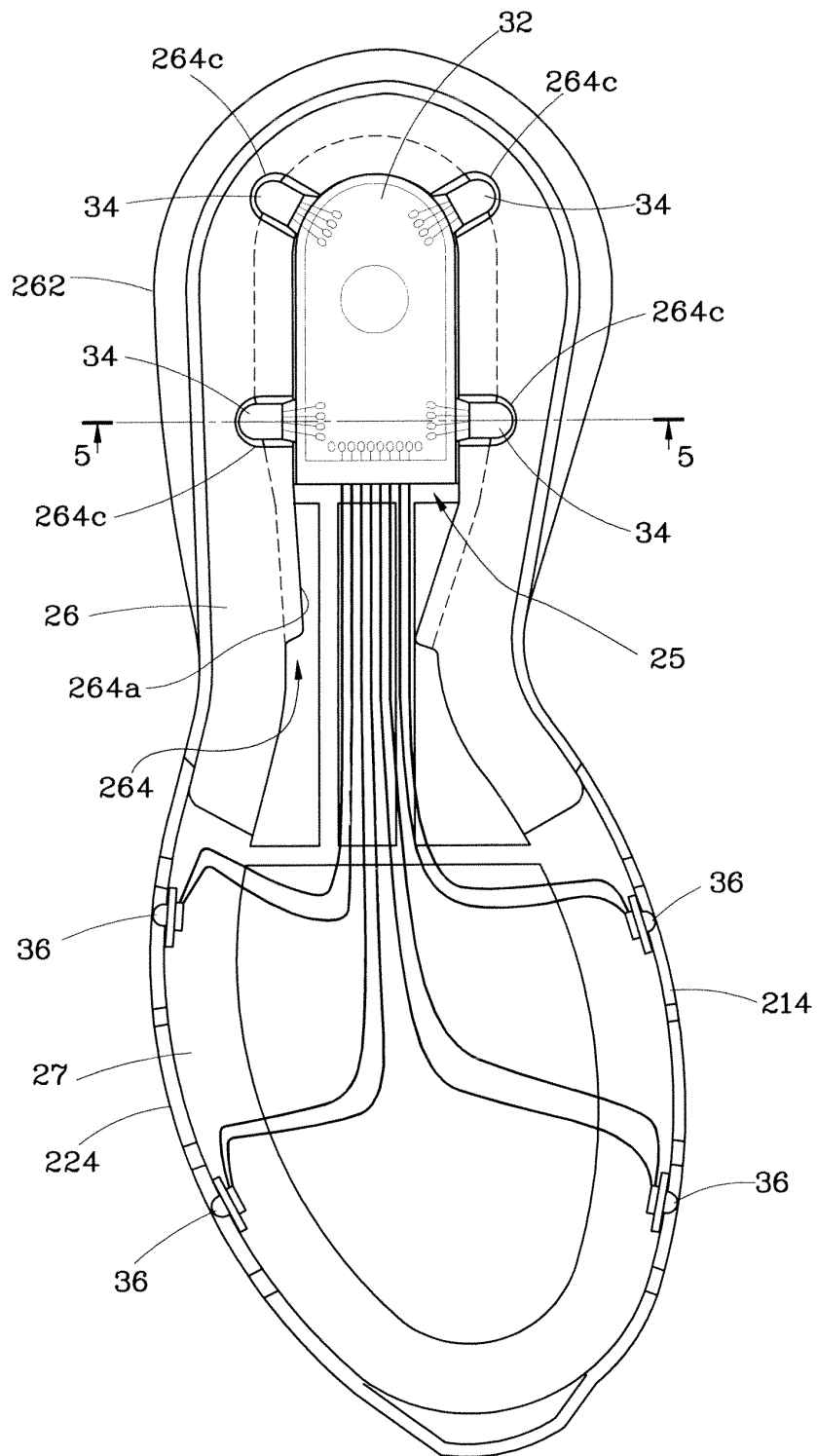

FIG. 4

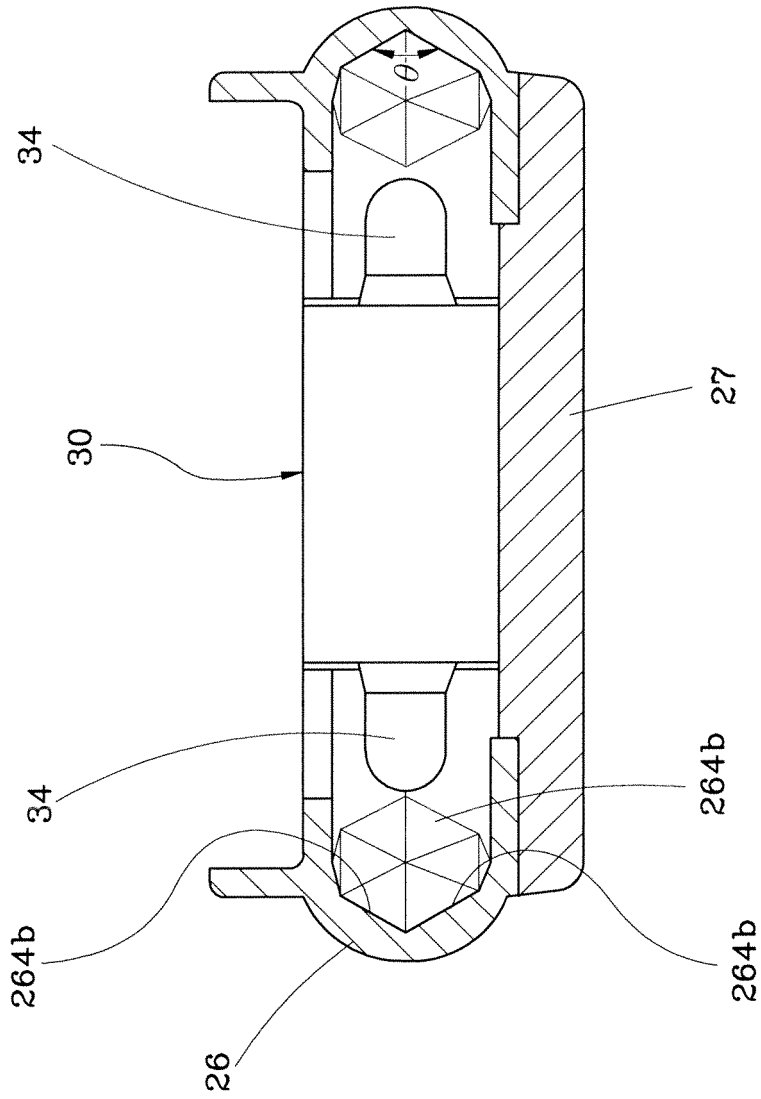

FIG.5

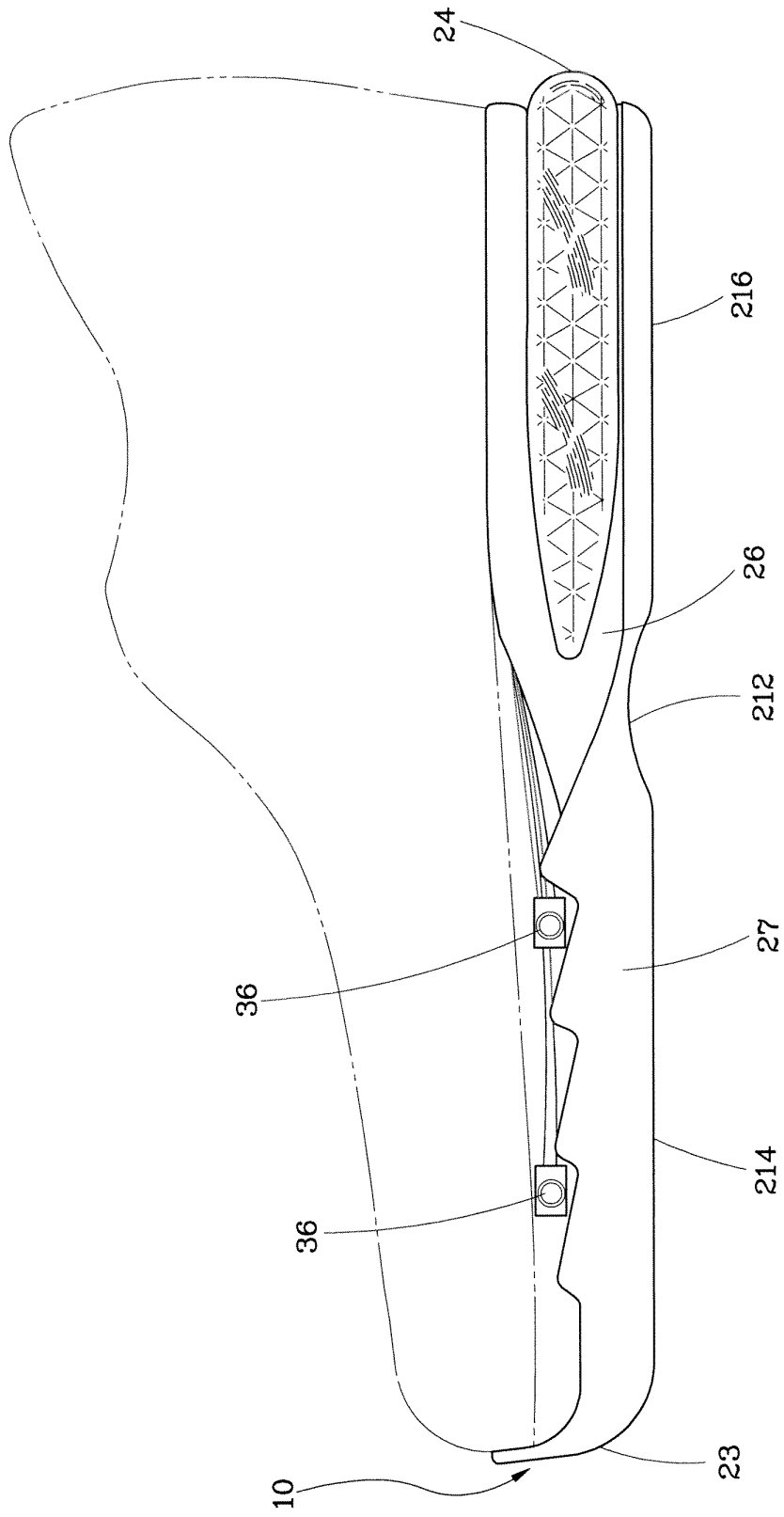

FIG. 6



EUROPEAN SEARCH REPORT

Application Number
EP 13 15 9986

5

10

15

20

25

30

35

40

45

50

55

DOCUMENTS CONSIDERED TO BE RELEVANT			
Category	Citation of document with indication, where appropriate, of relevant passages	Relevant to claim	CLASSIFICATION OF THE APPLICATION (IPC)
X	US 5 930 921 A (SOROFMAN HOWARD [US] ET AL) 3 August 1999 (1999-08-03) * the whole document * -----	1-15	INV. A43B1/00 A43B13/00
X	US 5 237 760 A (ALTMAN PETER R [US] ET AL) 24 August 1993 (1993-08-24) * the whole document * -----	1	ADD. A43B3/00 F21V7/00
X	WO 94/15494 A1 (IDEA INC [US]; HUANG JING) 21 July 1994 (1994-07-21) * figures 9-14 * * page 10, line 10 - page 11, line 22 * -----	1	
			TECHNICAL FIELDS SEARCHED (IPC)
			A43B F21V
The present search report has been drawn up for all claims			
Place of search The Hague		Date of completion of the search 23 July 2013	Examiner Millward, Richard
CATEGORY OF CITED DOCUMENTS X : particularly relevant if taken alone Y : particularly relevant if combined with another document of the same category A : technological background O : non-written disclosure P : intermediate document		T : theory or principle underlying the invention E : earlier patent document, but published on, or after the filing date D : document cited in the application L : document cited for other reasons & : member of the same patent family, corresponding document	

1
EPO FORM 1503 03 82 (P04C01)

**ANNEX TO THE EUROPEAN SEARCH REPORT
ON EUROPEAN PATENT APPLICATION NO.**

EP 13 15 9986

5

This annex lists the patent family members relating to the patent documents cited in the above-mentioned European search report. The members are as contained in the European Patent Office EDP file on The European Patent Office is in no way liable for these particulars which are merely given for the purpose of information.

23-07-2013

10

Patent document cited in search report	Publication date	Patent family member(s)	Publication date
US 5930921 A	03-08-1999	NONE	

US 5237760 A	24-08-1993	IT 1280027 B1 US 5237760 A	23-12-1997 24-08-1993

WO 9415494 A1	21-07-1994	AU 6093094 A CN 1090481 A EP 0680266 A1 WO 9415494 A1	15-08-1994 10-08-1994 08-11-1995 21-07-1994

15

20

25

30

35

40

45

50

55

EPO FORM P0459

For more details about this annex : see Official Journal of the European Patent Office, No. 12/82

REFERENCES CITED IN THE DESCRIPTION

This list of references cited by the applicant is for the reader's convenience only. It does not form part of the European patent document. Even though great care has been taken in compiling the references, errors or omissions cannot be excluded and the EPO disclaims all liability in this regard.

Patent documents cited in the description

- TW M408261 [0004]
- US 20120192462 A [0004]