

- [54] REJECTION TYPE FUSE HOLDER
- [75] Inventor: Robert S. Tillson, Terryville, Conn.
- [73] Assignee: General Electric Company, New York, N.Y.
- [22] Filed: Dec. 12, 1974
- [21] Appl. No.: 532,009

Related U.S. Application Data

- [62] Division of Ser. No. 433,824, Jan. 16, 1974, Pat. No. 3,890,032.
- [52] U.S. Cl. 339/186 R; 339/258 F
- [51] Int. Cl.² H01R 13/64
- [58] Field of Search 339/147, 184, 186, 252, 339/253, 256, 258, 259, 262

References Cited

UNITED STATES PATENTS

1,218,221	3/1917	Smith	339/258 F
2,942,228	6/1960	Swick	339/184 R
2,943,295	6/1960	Stewart.....	339/258 F

FOREIGN PATENTS OR APPLICATIONS

535,610 4/1941 United Kingdom 339/258 F

Primary Examiner—Joseph H. McGlynn
Attorney, Agent, or Firm—R. A. Cahill; W. C. Bernkopf; F. L. Neuhauser

[57] **ABSTRACT**

The fuse clip includes opposed arms, at least one of which is deflectable, for receiving the end terminal of a fuse cartridge. Maximum separation between the arms is determined by an abutment operatively associated with the deflectable arm. An obstruction is formed on at least one of the arms which is accommodated in an appropriately grooved fuse end terminal to accept insertion thereof. The obstruction engages an ungrooved fuse end terminal to thus require a separation of the arms precluded by the abutment, thereby rejecting insertion.

4 Claims, 7 Drawing Figures

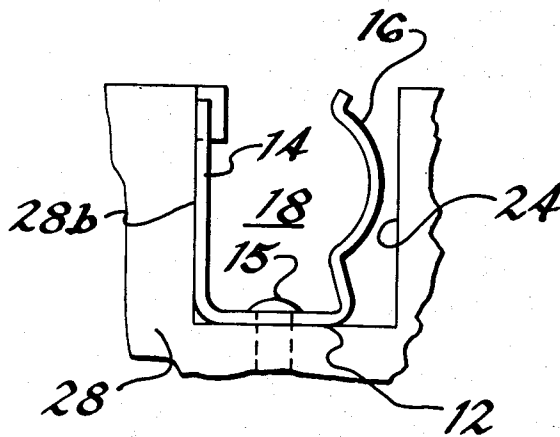

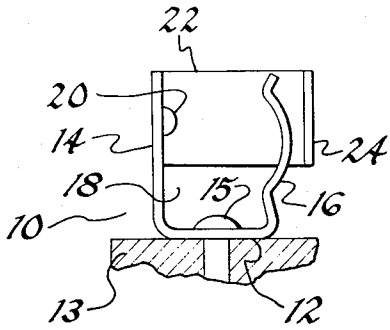

Fig. 1.

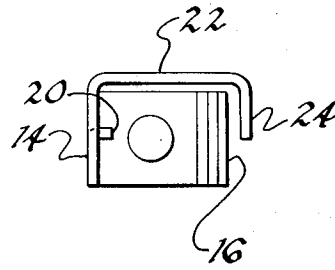

Fig. 2.

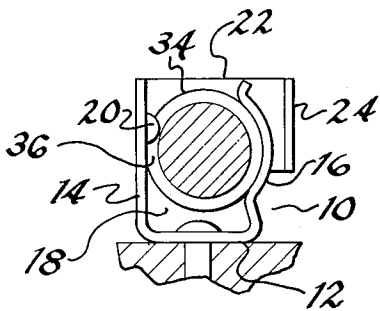

Fig. 6.

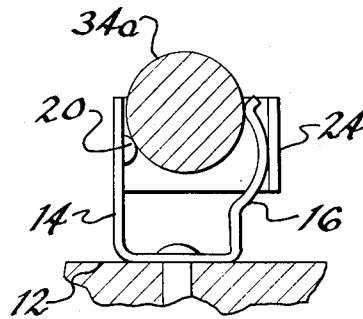

Fig. 7.

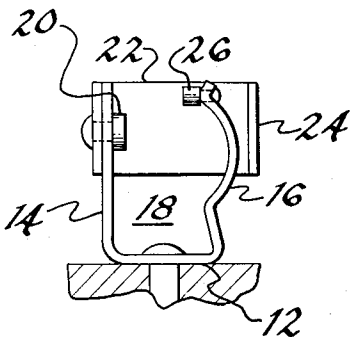

Fig. 3.

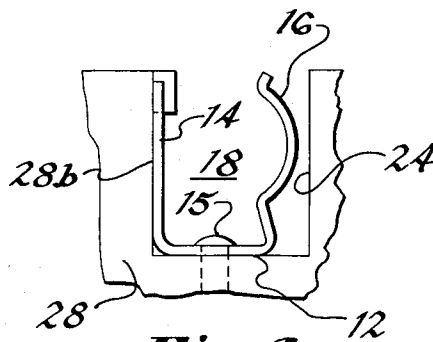

Fig. 4.

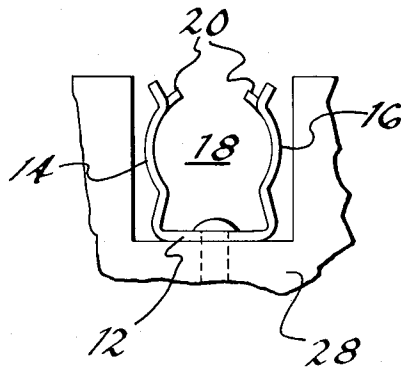

Fig. 5.

REJECTION TYPE FUSE HOLDER

This is a division of application Ser. No. 433,824, filed Jan. 16, 1974, now U.S. Pat. No. 3,890,032.

BACKGROUND OF THE INVENTION

This invention relates generally to a fuse clip structure for accepting an appropriately keyed fuse end terminal and rejecting an improperly keyed fuse end terminal. More specifically, the present invention relates to a fuse clip for only accepting a ferruled fuse end terminal which is appropriately grooved.

Rejection-type fuse clips for ferruled end terminals are known as evidenced by U.S. Pat. No. 2,943,295. In this patent, a separate interference means is assembled with a fuse clip, the latter including a pair of deflectable clamping arms formed for receiving a ferruled end terminal. The rejection means includes a rigid U-shaped member extending upwardly into the space between the clamping arms. The clamping arms deflect independently of the rejection means through appropriate slots in their side walls. The clearance across the U-shaped member corresponds to the outside diameter of a corresponding annular recess in a ferrule of an end terminal specifically formed for reception by the fuse clip. When such a ferrule is inserted, the clamping arms deflect outwardly independently of the rejection means to receive the non-recessed surface of the end terminal. The rejection means acts to prevent proper seating of an ungrooved ferrule.

Another type of rejection fuse clip for a ferrule type end terminal, disclosed in U.S. Pat. No. 2,558,581, includes a projection or protuberance on one side wall of an essentially rigid semicylindrical seat. When a ferruled end terminal not including a special recess for accommodating the aforesaid projection is presented for insertion into the clip, the projection in effect reduces the inside diameter of the seat to less than the ferrule diameter, thus to prevent proper seating therein which is determined and maintained by a separate screw clamp.

The disadvantage of the first form of fuse clip structure resides in the fact that an unknowledgeable or non-observant installer could partially insert an improper fuse such that, although not fully seated, it is nevertheless physically held and electrically inserted into the circuit to be protected. In the latter form, the fuse holder, though possibly more foolproof, is relatively expensive to manufacture and somewhat cumbersome to the installer. This is a potentially hazardous condition inasmuch as the circuit is not properly protected.

Accordingly, one object of the present invention is to provide a rejection-type fuse clip for fuses with ferruled end terminals which minimizes possible retention of improperly rated fuses.

Another object of the present invention is to provide a rejection type fuse holder of relatively simplified structure which is inexpensive to manufacture and easy to use.

Other objects of the present invention will be apparent to those skilled in the art.

SUMMARY OF THE INVENTION

Briefly stated, the present invention provides a fuse clip for reception of an appropriately formed end terminal of a fuse cartridge. The fuse clip, at at least one end of the fuse holder, includes a pair of spaced arms,

at least one of which being deflectable. At least one of the arms includes an arcuate mid-section for correspondingly receiving an arcuate portion of a ferruled fuse end terminal inserted in the pocket therebetween.

One of the arms carries an interference means or obstruction which extends laterally into the pocket adjacent the access opening thereto. In addition, a deflection limiting means or abutment is positioned externally of the pocket in closely spaced relation to the deflectable arm to limit the lateral dimension of the pocket opening induced by the forcible insertion of a ferruled end terminal. This maximum lateral dimension or clearance between the arms is adequate to admit the insertion of a ferruled end terminal keyed with a recess or groove located to accommodate the obstruction, but insufficient so as to deny insertion of an ungrooved end terminal since the obstruction bears against the outer surface of the end terminal to increase the clearance requisite to insertion; such clearance increase being prohibited by the abutment.

DESCRIPTION OF THE DRAWINGS

The subject matter which is regarded as the invention is particularly pointed out and distinctly claimed in the concluding portion of the specification. The invention, however, both as to organization and method of practice, together with further objects and advantages thereof, may be best understood by reference to the following description taken in conjunction with the accompanying drawings in which:

FIG. 1 is a side view of one fuse clip embodiment of the present invention.

FIG. 2 is a top view of the fuse clip shown in FIG. 1.

FIG. 3 is a side view of an alternative fuse clip embodiment of the invention.

Fig. 4 is a side view of another fuse clip embodiment of the present invention.

FIG. 5 shows still another fuse clip embodiment of the present invention.

FIG. 6 is a side view of the fuse clip embodiment of FIG. 1 illustrating acceptance of a properly keyed, ferruled fuse end terminal.

FIG. 7 is a side view of the fuse clip embodiment of FIG. 1 illustrating rejection of an improperly keyed, ferruled fuse end terminal.

Like reference numerals refer to corresponding parts throughout the several views of the drawings.

DESCRIPTION OF THE PREFERRED EMBODIMENTS

Referring to FIG. 1 of the drawings, which shows one embodiment of the invention, a fuse clip 10 is generally shown, the main body of which includes a base member 12 and two spaced apart clamping arms 14 and 16 which extend upwardly from the base member 12 in a cantilevered manner. Base member 12 is secured to a support 13 by a rivet or screw 15. The clamping arms 14 and 16 are separated from one another in their normal disposition to define a pocket 18 and are substantially parallel to one another. The clamping arm 16 includes an arcuate mid-portion for engaging a corresponding arcuate side of a ferruled end terminal of a cartridge fuse. An interference means or obstruction 20 is disposed on clamping arm 14 and extends laterally into pocket 18 to reduce the transverse clearance of the entrance or opening to the pocket defined by the upper end portions of the two clamping arms.

An L-shaped deflection limiting means, as seen in FIG. 2 of the drawings, has a leg portion 22 affixed to and extending from the side edge of clamping arm 14 transversely beyond the end of pocket 18 toward flexible clamping arm 16. Leg portion 22 terminates in a turned foot portion 24 located on the opposite side of arm 16 from pocket 18 to serve as a substantially rigid abutment limiting the maximum deflection of arm 16 and thus the maximum lateral dimension of the opening into the pocket.

In the alternative embodiment of the present invention shown in FIG. 3, an additional interference means or obstruction in the form of a post 26 is riveted or otherwise secured to the free end portion of arm 16 in transverse alignment with obstruction 20. Post 26 is provided to prevent deformation of the uppermost crooked portion of clamping arm 16 against abutment 24 upon attempted insertion of an end terminal of a cartridge fuse not keyed for reception in the fuse clip. Post 26 cooperates with obstruction 20 to reject insertion of an unkeyed, ferruled end terminal, while the former effectively resists insertion forces tending to flatten out the uppermost crooked portion of the clamping arm 16 against abutment 24, and thus over-ride the rejection feature of the invention. In addition, it is to be noted that the deflection limiting means can be separately affixed to the clamping arm 14 as shown in FIG. 3 as opposed to the integral nature of the attachment to the clamping arm shown in FIG. 2. It will also be noted that this attachment, in the form of a rivet, etc., can also mount or constitute in whole or in part the obstruction 20.

A further alternative embodiment of the invention is shown in FIG. 4 to include a clip body having arms and an interconnecting base in a similar configuration to that illustrated for the embodiments of FIGS. 1 and 3. However, mounting of the clip body and the deflection limiting means is provided by a mounting block 28. Specifically, the mounting block is formed having a U-shaped cavity with the clip body supported by the cavity floor 28a while arm 14 is situated against one cavity sidewall 28b. The other deflectable arm 16 is upstanding in closely spaced relation to the other cavity sidewall, which constitutes the deflection limiting abutment 24. In this embodiment, arm 14 is slotted to accommodate obstruction 20 which is formed on or attached to cavity sidewall 28b.

The embodiment of the invention shown in FIG. 5 of the drawings is similar to that shown in FIG. 4 except that the deflection limiting means is constituted by both sidewalls of the cavity formed in mounting block 28. Consequently, the arms 14 and 16 are identically, complementarily shaped and are both deflectable; their deflection movements being limited in magnitude by the closely spaced cavity sidewalls. In addition, the interference means is in the form of a pair of opposed obstructions 20 extending inwardly at the opening into cavity 18 from the clamping arms.

The mode of operation and principal advantage of the present invention can be understood from a comparison of FIGS. 6 and 7 of the drawings. In FIG. 6, a ferruled end terminal 34 is received in the fuse clip 10. An annular groove 36 in the end terminal 34 receives the interference means 20 and the outside or major diameter of the non-recessed portion of the end terminal

is dimensioned to correspond to the maximum clearance between the arms at the opening into the pocket as established by the deflection limiting means. In FIG. 7, a ferruled end terminal 34a not grooved to accept the interference means requires an opening clearance into the pocket in excess of the maximum allowed clearance. It is seen that the interference means bears against the outer surface of the end terminal, thus, in effect, adding its length to the major diameter of the end terminal to create a total clearance requirement exceeding that permitted by the limiting means 24. Entry into the pocket 18 is therefore denied. It will be noted that the location of the interference means adjacent the entrance or opening into the pocket affords rather complete rejection in that even partial insertion of an ungrooved end terminal is precluded. Thus the fuse clip of the present invention effectively precludes any retention whatsoever of an improperly rated fuse.

While a number of embodiments of the present invention have been specifically disclosed herein, other modifications will occur to those skilled in the art and it is desired to cover in the appended claims all such modifications as fall within the true spirit and scope of the invention.

We claim:

1. A fuse clip for accommodating a fuse end terminal appropriately keyed with a special recess, said fuse clip comprising, in combination:
 - A. a pair of spaced arms defining therebetween a pocket having a constricted opening for receiving a fuse end terminal, at least one of said arms being deflectable to accommodate enlargement of said pocket opening;
 - B. interference means approximate one of said arms and extending laterally into said pocket adjacent said opening;
 - C. limiting means disposed externally of said pocket adjacent said deflectable arm for limiting the deflection thereof so as to establish a maximum separation of said arms at said pocket opening corresponding to the major lateral dimension of a fuse end terminal having the keyed recess for accommodating said interference means upon insertion, said interference means engaging the outer surface of a fuse end terminal lacking the keyed recess to increase the separation of said arms at said pocket opening necessary for insertion to a spacing which is prohibited by said limiting means, thereby to reject insertion thereof; and
 - D. a mounting block for supporting said arms, said limiting means being provided by a surface of said block.
2. The fuse clip defined in claim 1, wherein said arms are situated in a cavity formed in said block, said limiting means being provided by a sidewall of said cavity.
3. The fuse clip defined in claim 2, wherein said interference means is carried by said other cavity wall for extension into said pocket.
4. The fuse clip defined in claim 2, wherein both of said arms are deflectable, said interference means is carried by at least one of said arms and said limiting means is provided by opposed sidewalls of said cavity disposed in deflection limiting physical relation with said arms.

* * * * *