

A. N. HUMPHREY.

Gang-Plows.

No. 136,062. Patented Feb. 18, 1873.

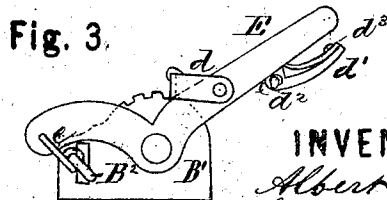
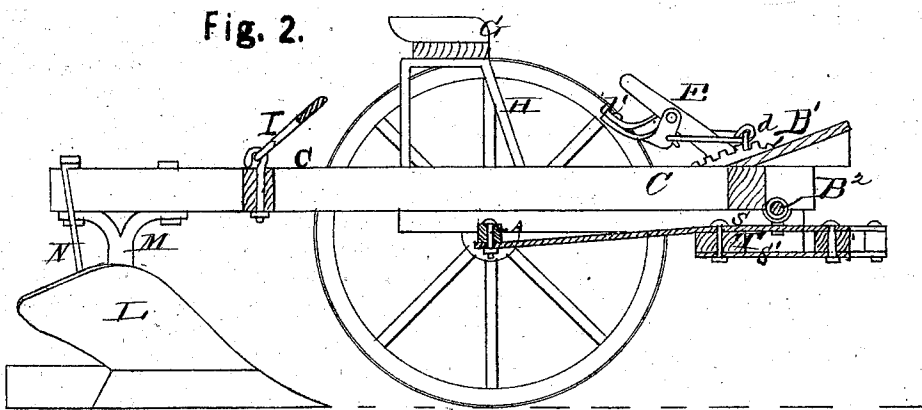
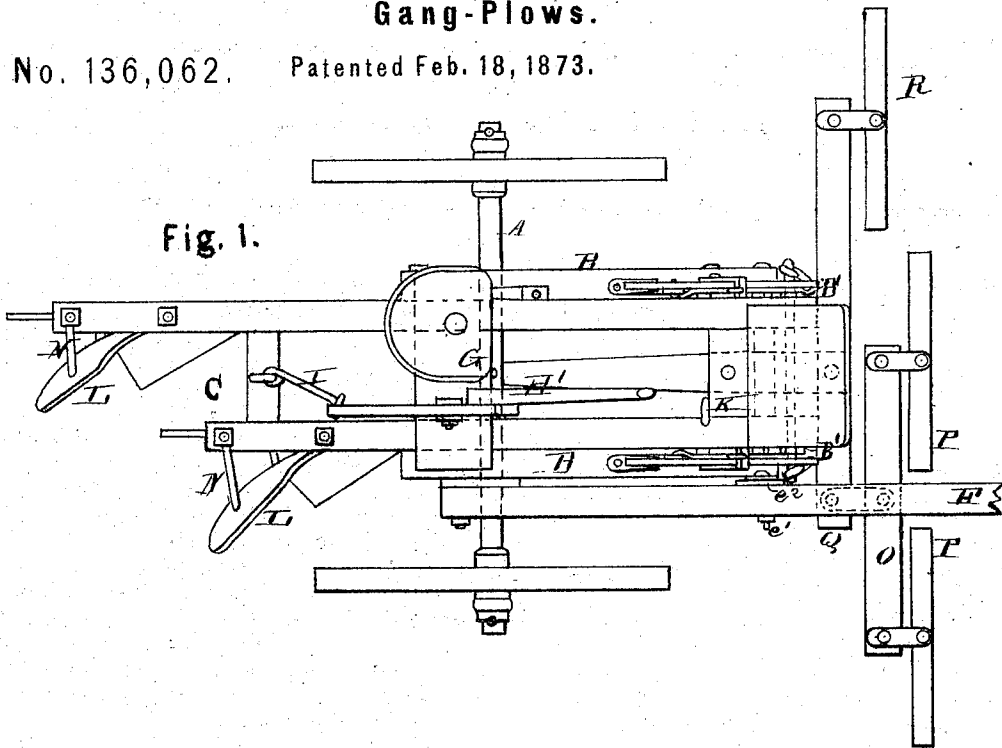

WITNESSES.

Phil. Mason,
C. B. Steele.

INVENTOR.

Albert N. Humphrey
Chipman & Fosmire & Co
Atty.

UNITED STATES PATENT OFFICE.

ALBERT N. HUMPHREY, OF BRODHEAD, WISCONSIN.

IMPROVEMENT IN GANG-PLOWS.

Specification forming part of Letters Patent No. 136,062, dated February 18, 1873.

To all whom it may concern:

Be it known that I, A. N. HUMPHREY, of Brodhead, in the county of Green and State of Wisconsin, have invented a new and valuable Improvement in Sulky Gang-Plows; and do hereby declare that the following is a full, clear, and exact description of the construction and operation of the same, reference being had to the annexed drawing making a part of this specification, and to the letters and figures of reference marked thereon.

Figure 1 of the drawing is a representation of a top view of my invention. Fig. 2 is a vertical section of my invention. Fig. 3 is a detail view of my invention.

My invention has relation to sulky gang-plows; and it consists in the construction and novel arrangement of the draft or riding and plow frames, the devices for raising and lowering said frames together or the plow-frames separately at the forward end to adjust the plows to different depths, the peculiar method of attaching the plows to the plow-frame; all substantially as and for the purpose specified.

Referring to the drawing, A represents the axle-tree, having its middle part bent or sunk and shouldered to receive the rear end of the draft-frame B, which is bolted directly to said axle-tree. The sides of said frame are notched to fit down over said axle-tree. By this arrangement the draft is strengthened and brought low, and the draft and plow frames allowed to work close together, thereby giving greater compass to the depth of plowing. The frame B has attached to the inner surfaces of the side bars, at their forward ends, metallic plates B¹, which project forward, and have vertical slots to receive a transverse rod, B², which, being secured to the under side of the plow-frame C, connects the two frames together at their forward ends. The rod B² is secured to the frame C by means of loops, and serves as a pivot for the frame C to work upon. The upper parts of the plates B¹ are cut to the form of segmental racks. Bell-crank levers E are pivoted to these plates on the outside, and connected, by means of links e, to the ends of the rod B². The sides of the plow-frame fit between the sides of the draft-frame; hence, when the levers E are lowered or raised, the forward end of the frame C is raised or low-

ered, as the case may be, and the plows thereby adjusted to the required depth of furrow. The levers E have bent lugs or pawls d pivoted to them. These pawls engage with the teeth of the racks, and are lifted from them by means of levers or latches d¹, constructed as shown, pivoted to the levers E, and connected to the lugs d by means of links d². When the hand is taken from the lever E a spring, d³, throws the lever d¹ back to its original position, and forces the lug into one of the notches of the rack, where it remains until the lever is again taken hold of. It will be observed that the lever E and latch d¹ are both grasped at once with the one hand, and thereby controlled as effectually as if both hands were used. When one only of the levers E is operated one side only of the plow-frame is raised, and thus the plows may be adjusted to surface irregularities. The draft-pole F is pivoted at its rear end to one side of the frame B. A bolt, e¹, passing through the pole near the forward end of the frame B, also passes through a slotted plate, e², secured to the adjacent side of the frame. When the nut on this bolt is loosened the two frames B C may be raised or lowered together at their forward ends. The driver's seat G is supported by standards H attached to the frame C. A bent lever, H', is pivoted to the board of the driver's seat, and extends forward. At its rear end the lever is connected to the frame C by means of a coupling, I. By lowering the forward end of said lever the plows may be raised entirely from the ground. K designates a hook or catch for holding the forward end of the lever down. L represents the plows, the standards M of which rise vertically, and, being bifurcated and spread open at their upper ends, are each secured to its appropriate frame-bar by means of two bolts. Diagonal braces N extend from the mold-boards to the top of the bars of the frame, and are each secured thereto by means of the hind bolt of the bifurcated standard. The bars of the frame C are of unequal length to allow the plows to be properly arranged for gang-plowing. O represents the double-tree of the draft attachments, holding the two single-trees P, and attached to the short arm of the evener Q, to the long arm of which is attached another single-tree marked R. The

evener is pivoted to a clevis or pair of plates, S S', the upper one of which runs back, and is secured to the axle-tree, while the under one is secured to a transverse bar, T, at the forward and under part of the frame B, as shown.

The draft is from three distinct parts of the axle-tree—from the middle part, through the plate S, and from nearer the ends by means of the draft-frame.

What I claim as my invention, and desire to secure by Letters Patent, is—

1. The combination and arrangement of the pivoted inner frame C carrying the plows L and transverse rod B², the outer draft-frame

B having the slotted segmental plates B¹ and levers E, substantially as specified.

2. The plate S secured to the axle A, and plate S' secured to the frame B, in combination with the evener Q, double-tree O, and single-trees P P R, substantially as described.

In testimony that I claim the above I have hereunto subscribed my name in the presence of two witnesses.

ALBERT NORMAN HUMPHREY.

Witnesses:

NATHAN P. MCNITT,
NAPOLEON ENFIELD.