

[54] **PRESSURE RELIEVING CLOSURE CAP**
 [75] Inventor: **Theo Gerdes**, Langenfeld, Germany
 [73] Assignee: **Blau KG Fabrik Fuer Kraftfahrzeugteile**, Langenfeld, Germany
 [22] Filed: **Nov. 2, 1972**
 [21] Appl. No.: **303,216**

[52] **U.S. Cl.**.....**220/205, 137/513.5, 220/200, 220/210**
 [51] **Int. Cl.**..... **B65d 51/16, F16k 17/00**
 [58] **Field of Search**..... **220/44 R, 24 GT; 137/493, 137/218, 513.5**

[56] **References Cited**

UNITED STATES PATENTS

3,047,235	7/1962	Eshbaugh et al.	220/44 R
3,194,262	7/1965	Hamilton et al.	137/513.5
3,333,836	8/1967	Bahout	137/513.5
3,580,273	5/1971	Schwarz	137/218
3,616,960	11/1971	Miller	220/44 R

FOREIGN PATENTS OR APPLICATIONS

1,081,237	12/1954	France	137/493
1,153,277	8/1963	Germany	220/44 R
1,145,304	10/1957	France	220/44 R
904,867	7/1949	Germany	137/493

OTHER PUBLICATIONS

R. Blau et al., Defense Publication Search Copy of Serial No. 340,456, filed 6/14/41, Published 5/25/43.

Primary Examiner—William I. Price
Assistant Examiner—Allan N. Shoap
Attorney, Agent, or Firm—Michael S. Striker

[57] **ABSTRACT**

A cap for closing a container comprises a housing defining an enclosed space, and a circular plate connected to the housing and subdividing the enclosed space into two chambers, one of which communicates with the exterior of the housing and the other of which communicates with the interior of the container. The circular plate is formed in its central region with an annular elevated portion facing the other chamber and surrounding a circular depression. At least one aperture is provided in the plate radially outwardly of the elevated portion and establishing communication between the two chambers. An elastically yieldable diaphragm is connected to the circular plate in its outer marginal portion, and is provided with a central hole bounded by an inner marginal portion which is normally urged by pretension in the diaphragm into contact with the elevated portion. At least one groove is provided in the elevated portion establishing communication between the aperture and the central opening and, consequently, between the two chambers in such a manner that gaseous fluid is permitted to pass between the two chambers through the groove at a first volumetric rate at all times, and at a higher second volumetric rate when the pressure in the one chamber exceeds that in the other chamber to a degree sufficient to deflect the inner marginal portion of the diaphragm out of contact with the elevated portion of the central plate, while liquid is prevented from leaving the interior of the container.

7 Claims, 3 Drawing Figures

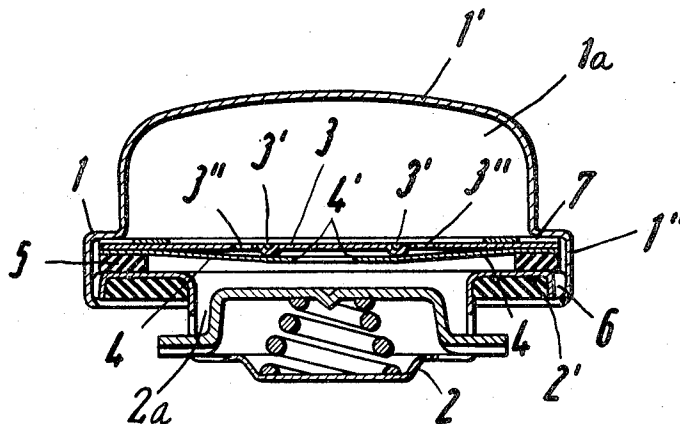

Fig. 1

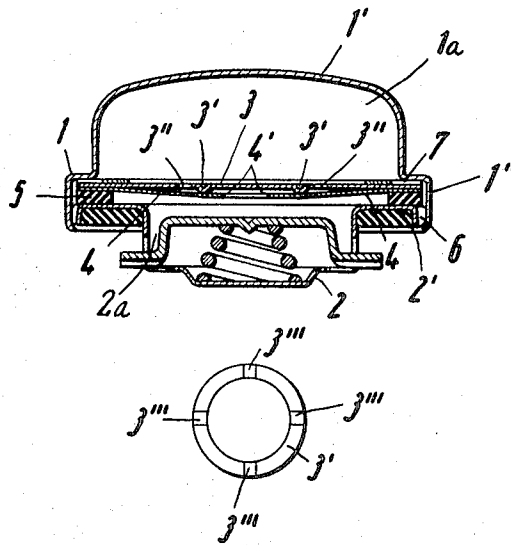
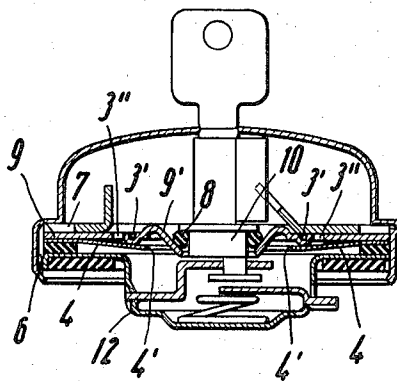

Fig. 1a

Fig. 2



PRESSURE RELIEVING CLOSURE CAP

BACKGROUND OF THE INVENTION

The present invention relates to a cap for closing containers, such as storage receptacles or pipes.

There are already known various caps for closing containers in which a flexible diaphragm abuts against one or more rigid profiled members so as to selectively close or open at least one pressure equalizing passage or aperture in such a manner that liquid is prevented from escaping from the container while the gas pressure inside the container is equalized with that of the ambient atmosphere.

It is already known, particularly in connection with caps for closing fuel tanks of motor vehicles, to obtain pressure equalization between the interior and exterior of the container by means of a diaphragm having a central hole and contacting an elevated portion of a rigid profiled member located inside the cap, the elevated portion being provided with a channel extending diametrically of the elevated portion and communicating with the central hole of the diaphragm, so that gas is permitted to pass through the central hole in the diaphragm while liquid even in droplet form is prevented from passing therethrough. The dimensions of the channel are so selected that only vapor or air can pass therethrough while liquid droplets adhere to the surfaces bounding the channel and are prevented from passing through the channel.

SUMMARY OF THE INVENTION

It is an object of the present invention to provide a cap for closing a container which is more effective than the heretofore known caps.

It is a further object of the present invention to provide a cap for closing a container which insures fast and reliable response to the change of the pressure conditions prevailing inside the container.

In pursuance of these objects and of others which will become apparent hereafter, one feature of the present invention resides, in a cap for closing a container, in an arrangement for controlling the passage of a gaseous fluid between the exterior and the interior of the container, which means includes a diaphragm clamped within the cap in the region of its circumferential marginal portion and urged by pretension into contact with an elevated portion of a rigid circular member connected to the cap interiorly thereof. A rigid insert is provided with through apertures located outwardly of the elevated portion of the circular member and with pressure-equalizing grooves. The elevated portion is of annular configuration, and the grooves are formed therein and extend radially thereof, establishing communication between the two sides of the annular elevated portion. The control diaphragm, which abuts against this annular elevated portion, is provided with a circular central hole bounded by an inner marginal portion which projects radially inwardly for the annular elevated portion. The interior of the container communicates with the exterior thereof via the central hole in the diaphragm, the radially extending grooves in the annular portion, the apertures in the rigid insert wall and the lower edge of the cap.

The invention will now be described with reference to the accompanying drawings.

BRIEF DESCRIPTION OF THE DRAWINGS

FIG. 1 is a sectional side view of a bayonet-type closure cap according to the invention;

FIG. 1a is a bottom-plan view of an elevated annular portion of the rigid insert member; and

FIG. 2 is a sectional side view of a modified embodiment of the invention provided with a mortise lock.

DESCRIPTION OF THE PREFERRED EMBODIMENTS

Discussing the drawings in detail, and first the embodiment shown in FIGS. 1 and 1a, it may be seen that the housing of the cap is comprised of an upper housing portion 1 which is formed with a grip portion 1' extending upwardly of the upper cap portion 1 and diametrically thereof and with a cap edge portion 1'' extending downwardly from the upper housing portion 1 and constituting a circumferential wall, and of a lower housing portion 2 of cup-shaped configuration having a flange edge portion 2' extending toward the cap edge portion 1''. A rigid insert 3 is clamped in the region of its marginal portion to the upper housing portion 1 and is provided with an annular elevated portion 3' in its central region which faces towards lower housing portion 2. The rigid insert 3 subdivides the space bounded by the upper housing portion 1 and the lower housing portion 2 in an upper chamber 1a and a lower chamber 2a. The rigid insert 3 is provided with a plurality of apertures 3'' located radially outwardly of the annular elevated portion 3' and establishing communication between the chambers 1a and 2a. A plurality of grooves 3''' — which are also illustrated in FIG. 1a — is provided in the annular elevated portion 3', extending radially thereof and establishing communication between a depression surrounded by the annular elevated portion 3' and the apertures 3'', as will be explained in more detail later on. In the lower chamber 2a, there is provided an annular sealing element 5 and a control diaphragm 4 clamped in the region of its outer marginal portion between the sealing element 5 and the insert 3. The diaphragm 4 is provided in its central region with a circular hole bounded by an inner marginal portion which is urged by pretension in the control diaphragm 4 into contact with the annular elevated portion 3' and projects radially inwardly beyond the same. The grooves 3''' are distributed over the circumference of the annular elevated portion 3' extending radially thereof and establish communication between the chamber 2a and the chamber 1a via the central hole 4' and the apertures 3''.

The cap is provided with a conventional spring-loaded bayonet-type connector which is known in the art and is not described. When the cap is connected with the container, by means of the connector, the lower chamber 2a communicates with the interior of the container. The cap operates for equalizing the pressure between the interior and exterior of the container in the following manner:

When the pressure inside the container is the same as that outside the container, the control diaphragm 4 is urged by the pretension therein into contact with the annular elevated portion 3' of the rigid insert 3; when the pressure inside the container and thus in the lower chamber 2a drops below the pressure outside the container and thus in the upper chamber 1a, the pressure drop across the diaphragm 4 displaces the inner mar-

ginal portion thereof downwardly and out of contact with the annular elevated portion 3' so that air from the outside of the container can enter the upper chamber 1a through the passages 6 and cutouts 7 of conventional design, and proceeds through the apertures 3'', 5 between the annular elevated portion 3' and the inner marginal portion of the diaphragm 4 and through the central hole 4' into the lower chamber 2a and from there into the interior of the container.

On the other hand, when the pressure inside the container exceeds that outside thereof, the pressure drop across the diaphragm 4 is added to the pretension therein, thus pressing the inner marginal portion thereof against the annular elevated portion 3'. In this manner, the only communication between the upper chamber 19 and the lower chamber 2a is established via the radially extending grooves 3''' provided in the annular elevated portion 3' so that the air at elevated pressure is permitted to pass from the interior of the container to the exterior thereof via the chamber 2a, 20 the central hole 4', the grooves 3''', the apertures 3'', the cutouts 7 and the passages 6. It is to be mentioned in this connection that the cutouts 7 may either be provided directly in the rigid insert 3, or a separate spacing ring may be provided between the rigid insert 3 and the upper cap portion 1, and the cutouts 7 may be provided therein.

A modified embodiment of the invention is illustrated in FIG. 2, in which the cap is provided with a mortise lock serving for locking the cap and thus preventing unauthorized opening of the container. In this embodiment, a rigid insert 9 is substituted for the rigid insert 3 of the previously-described embodiment of the invention, and is provided with a central opening through which the lock 10 extends into a lower housing portion 12. The rigid insert 9 is provided with an inner marginal portion 9' surrounding the central opening, and a sealing ring 8 is interposed between the inner marginal portion 9' and the lock 10. The construction and operation of the mortise lock 10 is entirely conventional and thus will not be discussed.

The rigid insert 9 is provided with an annular elevated portion 3' which is formed with grooves 3''' similar to those described in connection with the first embodiment of the invention. The operation of the cap is similar to that previously described. Accordingly, when the pressure inside the container exceeds that outside thereof, excess air can escape from the interior of the container through the central opening 4' of the control diaphragm 4, through the grooves 3''' provided in the elevated annular portion 3', through the holes 3'' provided in the rigid insert 9, to the outside of the cap and of the container through the cutouts 7 and the passages 6. On the other hand, when the pressure inside the container drops below the pressure outside the same, the diaphragm 4 which is pressed against the annular elevated portion 3' by pretension therein is displaced downwardly out of contact with the annular elevated portion 3' so that outside air can pass through the passages 6, the cutouts 7, the apertures 3'', through the gap between the annular elevated portion 3' and the inner marginal portion of the diaphragm 4, and through the control hole 4' to the interior of the container.

The pressure equalizing grooves 3''' which extend radially of the annular elevated portion 3' and which are distributed over the circumference thereof, can ei-

ther be notches machined in the annular elevated portion or depressions pressed into the same. The apertures 3'' which extend through the rigid insert 3 or 9 radially outwardly of the annular elevated portion 3' may preferably be located diametrically opposite one another and the combined cross-sections of the apertures may be so selected as to afford the required flow rate therethrough.

What is claimed as new and desired to be protected by Letters Patent is set forth in the appended claims.

1. In a cap for closing a container, a combination comprising first wall means defining an enclosed space; second wall means connected to said first wall means and subdividing said space into a first and a second chamber and including a circular plate formed with an annular elevated portion in the central region thereof facing said second chamber and surrounding a circular depression; means for establishing communication between said first chamber and the exterior of said first wall means; means for establishing communication between said second chamber and the interior of the container; means for establishing communication between said first and second chambers and including at least one aperture in said second wall means radially outwardly of said elevated portion; and means situated in said second chamber and operative for controlling the passage of a gaseous fluid through said aperture and including an elastically yieldable diaphragm having an outer marginal portion fluid-tightly connected with said circular plate and an inner marginal portion bounding a central hole in said diaphragm communicating with said depression, and normally urged by pretension in said diaphragm into contact with said elevated portion, and at least one groove extending in said elevated portion radially outwardly thereof for establishing communication between said depression and said aperture, whereby the gaseous fluid is permitted to pass at least from said second chamber into said first chamber at a first volumetric rate when the pressure in the former exceeds that in the latter, and from said first chamber into said second chamber at a second higher volumetric rate when the pressure in the former exceeds that in the latter to such a degree that said inner marginal portion of said diaphragm is deflected out of contact with said elevated portion of said circular plate.

2. A cap as defined in claim 1, and further comprising a plurality of additional grooves similar to said groove and distributed along the circumference of said annular elevated portion extending radially thereof.

3. A cap as defined in claim 2, wherein said grooves are notches cut into said annular elevated portion.

4. A cap as defined in claim 2, wherein said grooves are depressions pressed into said annular elevated portion.

5. A cap as defined in claim 2, wherein said grooves are undulated and extend at least partially circumferentially in said annular elevated portion.

6. A cap as defined in claim 1, and further comprising a plurality of additional apertures similar to said aperture and situated along a circle outwardly surrounding said annular elevated portion.

7. A cap as defined in claim 6, wherein said apertures are arranged in pairs diametrically opposite one another across said annular elevated portion.

* * * * *

UNITED STATES PATENT OFFICE
CERTIFICATE OF CORRECTION

PATENT NO. : 3 858 751
DATED : January 7, 1975
INVENTOR(S) : Theo GERDES

It is certified that error appears in the above-identified patent and that said Letters Patent are hereby corrected as shown below:

In the heading insert

(30) Foreign application priority date
November 10, 1971, Germany P 21 55 854.3

Signed and sealed this 20th day of May 1975.

(SEAL)
Attest:

RUTH C. MASON
Attesting Officer

C. MARSHALL DANN
Commissioner of Patents
and Trademarks