

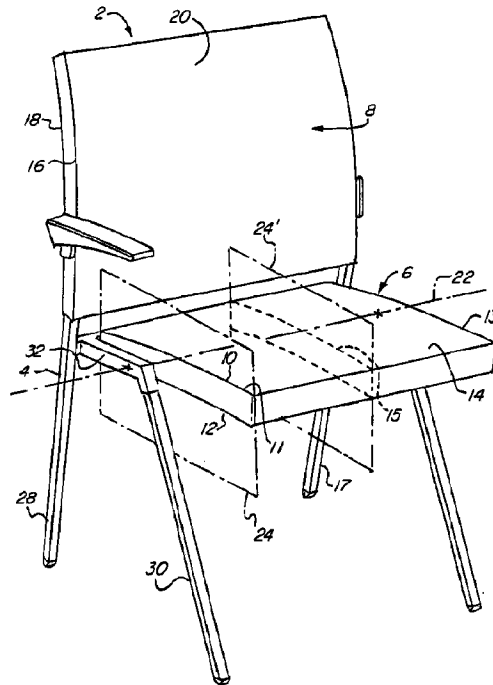

(86) Date de dépôt PCT/PCT Filing Date: 2016/05/12
 (87) Date publication PCT/PCT Publication Date: 2016/11/17
 (45) Date de délivrance/Issue Date: 2022/06/07
 (85) Entrée phase nationale/National Entry: 2017/11/10
 (86) N° demande PCT/PCT Application No.: US 2016/032050
 (87) N° publication PCT/PCT Publication No.: 2016/183299
 (30) Priorité/Priority: 2015/05/13 (US14/711,409)

(51) Cl.Int./Int.Cl. *A47C 3/04* (2006.01),
A47C 1/121 (2006.01), *A47C 1/124* (2006.01),
A47C 3/18 (2006.01), *A47C 4/04* (2006.01),
A47C 4/06 (2006.01), *A47C 5/06* (2006.01),
A47C 7/02 (2006.01), *A47C 7/60* (2006.01)
 (72) Inventeur/Inventor:
 OLARTE, ALVARO MAURICIO, US
 (73) Propriétaire/Owner:
 SERIES INTERNATIONAL, LLC, US
 (74) Agent: ROBIC

(54) Titre : CHAISE EMPILABLE
 (54) Title: STACKABLE CHAIR



(57) Abrégé/Abstract:

A stacking chair with a frame connected to a rotating seating portion and backrest portion each of the seating portion and backrest portion having matching profiles such that when stacked the weight of the chairs is distributed across facing surfaces that nest together due to matching profiles, the seating portion may rotate through an angle of rotation greater than 90 degrees and the seating and/or backrest portions may include a injection molded foam interior surrounding an internal frame and with a removable cover on the outside of the foam.

(12) INTERNATIONAL APPLICATION PUBLISHED UNDER THE PATENT COOPERATION TREATY (PCT)

(19) World Intellectual Property
Organization
International Bureau(10) International Publication Number
WO 2016/183299 A1(43) International Publication Date
17 November 2016 (17.11.2016)

(51) International Patent Classification:

A47C 3/04 (2006.01) A47C 4/42 (2006.01)
A47C 3/00 (2006.01) A47C 4/00 (2006.01)
A47C 4/28 (2006.01)

(21) International Application Number:

PCT/US2016/032050

(22) International Filing Date:

12 May 2016 (12.05.2016)

(25) Filing Language:

English

(26) Publication Language:

English

(30) Priority Data:

14/711,409 13 May 2015 (13.05.2015) US

(71) Applicant: **SERIES INTERNATIONAL, LLC** [US/US];
20900 Northeast 30th Avenue; Suite 901, Aventura, FL
33180 (US).

(72) Inventor: **OLARTE, Alvaro, Mauricio**; 2600 Island
Boulevard, Apt.1404, Aventura, FL 33160 (US).

(74) Agents: **WINTER, Gene, S.** et al.; St.Onge Steward John-
ston & Reens LLC, 986 Bedford Street, Stamford, CT
06905 (US).

(81) Designated States (unless otherwise indicated, for every
kind of national protection available): AE, AG, AL, AM,

AO, AT, AU, AZ, BA, BB, BG, BH, BN, BR, BW, BY,
BZ, CA, CH, CL, CN, CO, CR, CU, CZ, DE, DK, DM,
DO, DZ, EC, EE, EG, ES, FI, GB, GD, GE, GH, GM, GT,
HN, HR, HU, ID, IL, IN, IR, IS, JP, KE, KG, KN, KP, KR,
KZ, LA, LC, LK, LR, LS, LU, LY, MA, MD, ME, MG,
MK, MN, MW, MX, MY, MZ, NA, NG, NI, NO, NZ, OM,
PA, PE, PG, PH, PL, PT, QA, RO, RS, RU, RW, SA, SC,
SD, SE, SG, SK, SL, SM, ST, SV, SY, TH, TJ, TM, TN,
TR, TT, TZ, UA, UG, US, UZ, VC, VN, ZA, ZM, ZW.

(84) Designated States (unless otherwise indicated, for every
kind of regional protection available): ARIPO (BW, GH,
GM, KE, LR, LS, MW, MZ, NA, RW, SD, SL, ST, SZ,
TZ, UG, ZM, ZW), Eurasian (AM, AZ, BY, KG, KZ, RU,
TJ, TM), European (AL, AT, BE, BG, CH, CY, CZ, DE,
DK, EE, ES, FI, FR, GB, GR, HR, HU, IE, IS, IT, LT, LU,
LV, MC, MK, MT, NL, NO, PL, PT, RO, RS, SE, SI, SK,
SM, TR), OAPI (BF, BJ, CF, CG, CI, CM, GA, GN, GQ,
GW, KM, ML, MR, NE, SN, TD, TG).

Published:

- with international search report (Art. 21(3))
- before the expiration of the time limit for amending the
claims and to be republished in the event of receipt of
amendments (Rule 48.2(h))

(54) Title: STACKABLE CHAIR

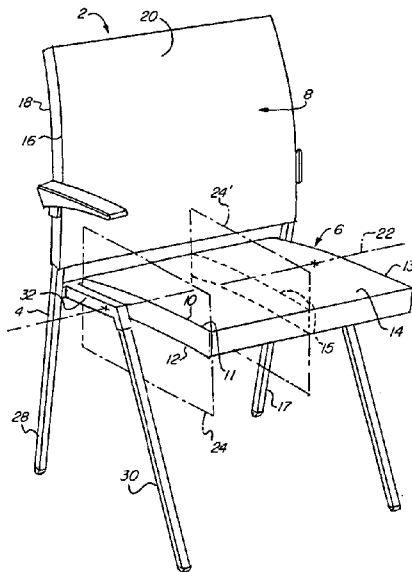

FIG. 1

(57) Abstract: A stacking chair with a frame connected to a rotating seating portion and backrest portion each of the seating portion and backrest portion having matching profiles such that when stacked the weight of the chairs is distributed across facing surfaces that nest together due to matching profiles, the seating portion may rotate through an angle of rotation greater than 90 degrees and the seating and/or backrest portions may include a injection molded foam interior surrounding an internal frame and with a removable cover on the outside of the foam.



WO 2016/183299 A1

-1-

TITLE OF INVENTION

STACKABLE CHAIR

FIELD OF THE INVENTION

[0001] The invention relates to chairs, more particularly chairs that are foldable and/or stackable.

BACKGROUND OF THE INVENTION

[0002] There are many versions of stacking chairs available that are designed for temporary seating in small and large areas, auditoriums or other event spaces. In one exemplary use of such chairs, a school may have a gymnasium that serves both for athletic purposes and for school meeting purposes. Folding chairs are needed for the meeting purposes, but would get in the way of the athletic uses. Therefore, chairs have been designed to stack upon each other so that when not in use, they can be stored in a relatively small space.

[0003] The process of un-stacking and stacking the chairs for storage and use often causes the chair frames to rub against each other which can damage the finish. In some cases, metal on metal contact can cause chairs to become stuck due to the concentration of the weight of many chairs onto relatively small contact areas. For example, the bottom two chairs in a stack of ten or more may become stuck together or difficult to remove from each other.

[0004] In addition, many of the stacking chairs do not include the ability to have a tilting seating surface. Some common folding chairs may fold flat, for stacking when flat, but when opened, the seating area often cannot be

- 2 -

tilted relative to a generally stationary frame. Since many stacking chairs are designed for frame to frame contact, padding on the chairs is often minimal because the padding takes up a large amount of space. Since some prior art stacking chairs are often designed for frame on frame contact to avoid surface to surface contact of the upholstered seat, adding padding reduces the number of chairs that can be stacked and still fit in typical door heights found in many buildings.

SUMMARY OF THE INVENTION

[0005] One object of the invention is to provide a stacking chair that distributes the mass of multiple chairs across a relatively large surface area.

[0006] Another object of the invention is to provide a stacking chair that avoids contact between legs and/or reduces the contact force between legs to reduce the likelihood that chairs will become stuck together or damaged upon stacking.

[0007] Yet another object of the invention is to provide a tilt mechanism that allows for increased rotation of the seat of the chair, which may provide increased space in aisles which could make it easier people to fill in rows while reducing the spacing between rows.

[0008] Yet other objects of the invention are to provide a comfortable stacking chair that is padded and is also space saving in storage.

[0009] These and other objects are achieved by providing a chair with a frame connected to a rotating seating portion and backrest portion each of the seating portion and backrest portion having matching profiles such that when stacked the weight of the chairs is distributed across facing surfaces that nest together due to matching profiles, the seating portion may rotate through an

- 3 -

angle of rotation greater than 90 degrees and the seating and/or backrest portions may include a injection molded foam interior surrounding an internal frame and with a removable cover on the outside of the foam.

[0010] In one aspect one cross section of the seating portion defines a first set of two profiles of matching shape one of which corresponds to a seating surface, and a cross section of the backrest portion defines a second set of two profiles of matching shape one of which corresponds to a backrest surface. The seating or backrest surfaces may be curved in a first plane perpendicular to a second plane where the second plane corresponds to the first or second set of two profiles. The seating portion may rotate about an axis parallel to the first plane and the axis of rotation may be located between the first set of two profiles.

[0011] The first or second sets of two profiles may correspond to 25%-100% or preferably 50%-90% of the corresponding seating or backrest surfaces across the corresponding seating or backrest surfaces and along the axis. In some cases the frame has a first section of a thickness less than a thickness of the seating portion where the axis passes through the first section. This may help avoid frame to frame contact.

[0012] A guard may be connected or may surround to the first section and may extend below a bottom of the first section at a distance corresponding to a difference between a thickness of the seating portion and the first thickness. This may enable contact between both the guard and the seating/backrest surfaces when chairs are stacked. The top and bottom surfaces of the guard may have profiles that match to enable nesting of the guards when stacked.

[0013] The seating portion may be configured to rotate freely relative to the frame between first and second positions such that an angle of rotation

- 4 -

between the first and second positions is greater than 90 degrees. In some cases, this may allow for additional space in rows of seats as people move in and out of the rows.

[0014] An interior cavity of the seating or backrest portions may include an internal frame and a compressible padding material injection molded around the internal frame. This may add comfort to the chair while also providing sufficient structural rigidity and resilience in a compact size to enable easy stacking and storage.

[0015] In order to avoid frame on frame contact, the first section of the frame may have a thickness greater than that of the seating portion. The seating portion may be connected to the first section at a rotation axis located between first and second surfaces of the seating portion wherein at least part of the first surface and at least part of the second surface define two matching profiles and the first surface is a seating surface. A second thickness measured between the first and second surface may be greater than the first thickness. This may cause the first sections to be spaced apart when chairs are stacked.

[0016] In some cases two or more chairs are provided in a stacked configuration. The first chair is configured to stack on the second chair such that the second surface the second chair is in contact with the first surface of the first chair. In this configuration, the first sections of the chairs are spaced apart. The first and second surfaces of the respective chairs may nest where contact occurs due to the matching profiles. It is understood that only part of the surfaces may be in contact/nest.

[0017] In some cases a contact area is defined where the surfaces meet and the second thickness may be measured from a point in the contact

- 5 -

area. The contact area may be 25%-100% or 50%-75% of a size of the first surface. The contact area may be at least 75% of the size of the first surface.

[0018] A guard may be connected to the first section and may extend below a bottom of the first section at a distance corresponding to a difference between the first thickness and second thickness. The guard may define top and bottom surfaces having matching profiles. This guard may also cover space between the first section and the seating portion where the rotation mechanism is housed in order to avoid or reduce the possibility of pinching of fingers in this space.

[0019] In some cases a rolling support has two axles spaced apart and receives the stacking chairs thereon such that a center of gravity of the stack of chairs is located between the two axles. In some configurations, thirteen chairs or possibly more can fit on the rolling support within eighty inches.

[0020] In other aspects the chair is provided with a leg portion of the frame having a first thickness. At least one cross section of the backrest portion may define a set of two profiles of matching shape one of which corresponds to a backrest surface. At least one of the seating or backrest surfaces may be curved in a first plane perpendicular to a second plane corresponding to the set of two profiles. A second thickness may be defined between the set of two profiles where the second thickness is greater than the first thickness. This may enable the leg portions of chairs to be spaced apart when stacked.

[0021] The curve in the first plane may also center the chairs relative to each other when stacked to avoid or reduce frame to frame contact where the first portion of one chair is approximately perpendicular to or overlaps the top of the leg.

- 6 -

[0022] In some cases a first section of the frame has a third thickness, and the seating portion is connected to the first section at a rotation axis. A fourth thickness may be defined between first and second surfaces of the seating portion wherein the fourth thickness is greater than the third thickness. This may avoid contact between the first sections of two chairs when stacked.

[0023] The seating portion may be configured to rotate freely relative to the frame between first and second positions such that an angle of rotation between the first and second positions is greater than 90 degrees. In some cases the set of two profiles correspond to at least 50% or at least 75% of the first and second surfaces.

[0024] In other aspects a folding chair is provided. A seating portion of the chair has first and second surfaces and an interior cavity. The interior cavity may have a compressible padding material. The seating portion may be connected to and configured to rotate relative to the frame about a rotation axis between first and second positions such that an angle of rotation between the first and second positions is greater than 90 degrees. This may enable added spacing in aisles/rows of seats as people fill in the rows.

[0025] Rotation from the first position towards the second position may move the seating portion towards a rotational equilibrium is caused by weight imbalance of the seating portion. The weight imbalance may exist in the first position and be relative to the rotation axis when no added weight or no user is on the seating surface. This may allow the seating portion to move an end of the seating element past a vertical axis passing through the rotation axis.

[0026] A front leg section of the frame may extend along a leg axis and in the second position, the seating portion may align parallel to the leg axis. A rotational equilibrium position of the seating portion may be defined where the seating portion is balanced about the axis of rotation. The rotational

equilibrium position may be located at an angle relative to the first position that is greater than the angle of rotation. This may enable the seating portion to rotate easily.

[0027] In some cases a backrest portion is connected to the frame and may prevent rotation of the seating portion beyond the angle of rotation.

[0028] An improved covering system is also contemplated. The chair may have a frame defining a backrest support. A channel may be connected to the frame and may have at least one inwardly turned rib and an inner void. A cover may have an open end and two sides, the open end configured to receive the backrest support. A section of the open end may define an elongated loop extending in a direction between the two sides. A c-shaped elongated member may be configured to insert into the elongated loop such that the rib can be positioned between two parts of the elongated loop and the two parts are clamped within the c-shaped elongated member to secure the cover to the frame.

[0029] In some cases. A cross section of the seating portion and a cross section of the backrest portion of the chair may each define two matching profiles corresponding to at least part of the first and second surfaces. At least one pair of the two matching profiles may be curved. In some cases, the seating portion rotates about an axis located between the first and second surfaces of the seating portion.

[0030] Hence, according to a broad aspect, the invention provides a chair adapted to stack, the chair comprising: a frame; a seating portion connected to the frame; a backrest portion connected to the frame; at least one cross section of the seating portion defining a first set of two profiles of matching shape one of which corresponds to a seating surface; at least one cross section of the backrest portion defining a second set of two profiles of matching shape one of which corresponds to a backrest surface; and at least one of the seating or backrest surfaces is curved in a first plane perpendicular to a second plane corresponding to the first or second set of two profiles; wherein the seating portion rotates about an axis parallel to the first plane and

is located between the first set of two profiles.

According to another broad aspect, the invention provides system of stacking chairs, the system comprising at least two chairs, each chair comprising: a frame including a first section defining a first thickness; a seating portion connected to the first section at a rotation axis, the rotation axis located between first and second surfaces of the seating portion wherein at least part of the first surface and at least part of the second surface define two matching profiles and the first surface is a seating surface, the seating portion rotates about the rotation axis, wherein a second thickness measured between the first and second surface is greater than the first thickness, and wherein a first one of the at least two chairs is configured to stack under a second one of the at least two chairs.

According to a further broad aspect, the invention provides chair adapted to stack, the chair comprising: a frame having at least one leg portion, the at least one leg portion having a first thickness; a seating portion connected to the frame at a rotation axis, the rotation axis located between first and second surfaces of the seating portion wherein the first surface is a seating surface, the seating portion rotates about the rotation axis; a backrest portion connected to the frame; at least one cross section of the backrest portion defining a set of two profiles of matching shape one of which corresponds to a backrest surface; at least one of the seating or backrest surfaces is curved in a first plane perpendicular to a second plane corresponding to the set of two profiles; and a second thickness defined between the set of two profiles wherein the second thickness is greater than the first thickness.

According another broad aspect, there is provided a chair adapted to stack, comprising: a frame; a seating portion connected to the frame, wherein the seating portion rotates about an axis parallel to a first plane, the axis being located between a first set of two profiles having matching curved shape, the first set of two profiles being defined by at least one cross section of the seating portion, the at least one cross section being located in a second plane perpendicular to the axis and the first plane and the first set of two profiles being located on first and second surfaces of the seating portion, one of the first and second surfaces being a seating surface; a backrest portion connected to the frame so that the backrest portion is in a fixed vertical position; and a second set of two profiles of matching curved shape defined by at least one cross section of the backrest

portion, the at least one cross section of the backrest portion being located in the second plane and the second set of two profiles being located on first and second surfaces of the backrest portion, wherein one of the first and second surfaces is a backrest surface, and wherein at least one of the seating or backrest surfaces is curved in the first plane.

According to a further broad aspect, there is provided a chair adapted to stack, comprising: a frame; a seating portion connected to the frame; a backrest portion connected to the frame; at least one cross section of the seating portion defining a first set of two profiles of matching shape the first set of two profiles located on first and second surfaces of the seating portion, one of the first and second surfaces being a seating surface; and at least one cross section of the backrest portion defining a second set of two profiles of matching shape; wherein the second set of two profiles is located on first and second surfaces of the backrest portion and one of the first and second surfaces is a backrest surface; wherein at least one of the seating or backrest surfaces is curved in a first plane perpendicular to a second plane, wherein the first and second sets of two profiles are located in the second plane, and wherein the first and second sets of two profiles are curved; wherein the at least one cross section of the seating portion and the at least one cross section of the backrest portion are located in the second plane; wherein the seating portion rotates about an axis parallel to the first plane and is located between the first set of two profiles; wherein the frame comprises a first section with a first thickness, the axis passing through the first section; and wherein a guard is connected to the first section and extends below a bottom of the first section at a distance corresponding to a difference between a thickness of the seating portion and the first thickness.

According to another broad aspect, there is provided a system of multiple chairs, comprising: a first one of at least two chairs; a second one of at least two chairs, the at least two chairs each having: a frame including a first section defining a first thickness; and a seating portion connected to the first section at a rotation axis, the rotation axis being located between first and second surfaces of the seating portion; wherein at least part of the first surface and at least part of the second surface define two matching profiles which are curved and the first surface is a seating surface; wherein a second thickness measured between the first and second surface is greater than the first thickness; and

wherein the first one of the at least two chairs is configured to stack on the second one of the at least two chairs such that the at least part of the second surface of the second one of the at least two chairs is in contact with the at least part of the first surface of the first one of the at least two chairs such that the first sections of the at least two chairs are spaced apart.

According to a further broad aspect, there is provided a chair adapted to stack, comprising: a frame including a first section defining a first thickness; and a seating portion connected to the first section at a rotation axis, the rotation axis being located between first and second surfaces of the seating portion; wherein at least part of the first surface and at least part of the second surface define two matching profiles which are curved and wherein the first surface is a seating surface; wherein a second thickness measured between the first and second surfaces is greater than the first thickness; and wherein a guard is connected to the first section and extends below a bottom of the first section at a distance corresponding to a difference between the first thickness and second thickness.

According to another broad aspect, there is provided a chair adapted to stack, comprising: a frame having at least one leg portion, the at least one leg portion having a first thickness measured between two outer portions of the at least one leg portion at an axis; a seating portion connected to the frame; and a backrest portion connected to the frame; wherein at least one cross section of the backrest portion defines a set of two profiles of matching curved shape, the set of two profiles being located on respective ones of first and second surfaces of the backrest portion, one profile of the set of two profiles being located on a backrest surface; wherein the seating surface and the backrest surface are both curved in a first plane perpendicular to a second plane, the set of two profiles being located in the second plane; wherein a second thickness is defined between the set of two profiles and wherein the second thickness is greater than the first thickness; and wherein the seating portion rotates about the axis and the axis is parallel to the first plane and located between the set of two profiles.

According to a further broad aspect, there is provided a chair adapted to stack, comprising: a frame having at least one leg portion, the at least one leg portion having a first thickness measured between two outer portions of the at least one leg portion; a

seating portion connected to the frame; a backrest portion connected to the frame; wherein at least one cross section of the backrest portion defines a set of two profiles of matching curved shape, the set of two profiles being located on respective ones of first and second surfaces of the backrest portion, one profile of the set of two profiles being located on a backrest surface; wherein at least one of the seating or backrest surfaces is curved in a first plane perpendicular to a second plane, the set of two profiles being located in the second plane; wherein a second thickness is defined between the set of two profiles and wherein the second thickness is greater than the first thickness; wherein a first section of the frame has a third thickness, the seating portion being connected to the frame at the first section at a rotation axis; and wherein a fourth thickness is defined between first and second surfaces of the seating portion and wherein the fourth thickness is greater than the third thickness.

According to another broad aspect, there is provided a chair adapted to stack, comprising: a frame; a seating portion connected to the frame; a backrest portion connected to the frame; a first set of two matching profiles defined by at least one cross section of the seating portion, the at least one cross section located in a second plane perpendicular to a first plane, the first set of two profiles being located on first and second surfaces of the seating portion, one of the first and second surfaces being a seating surface, the first plane being parallel to a width-wise axis of the chair which extends from left to right through the frame; and a second set of two profiles of matching curved shape defined by at least one cross section of the backrest portion, the at least one cross section of the backrest portion being located in the second plane and the second set of two profiles being located on first and second surfaces of the backrest portion and one of the first and second surfaces is a backrest surface, wherein at least one of the seating or backrest surfaces is curved in the first plane.

According to a further broad aspect, there is provided a system of multiple chairs, comprising: a first one of at least two chairs; a second one of at least two chairs, the at least two chairs each having: a frame including a first section defining a first thickness; a seating portion; and a backrest portion; wherein the seating portion is connected to the first section at the first section of the frame through which a width-wise axis passes through, the width wise axis extending from left to right of the at least two chairs and the

axis located between first and second surfaces of the seating portion; wherein at least part of the first surface of the seating portion and at least part of the second surface of the seating portion define a first set of two matching profiles and the first surface of the seating portion is a seating surface, the backrest portion having first and second surfaces wherein at least part of the first surface of the backrest portion and at least part of the second surface of the backrest portion define a second set of two matching profiles and the first surface of the backrest portion is a backrest surface; wherein at least one of the first set or the second set of two matching profiles is curved; wherein a second thickness measured between the first and second surfaces is greater than the first thickness; wherein the first one of the at least two chairs configured to stack on the second one of the at least two chairs such that the at least part of the second surface of the second one of the at least two chairs is in contact with the at least part of the first surface of the first one of the at least two chairs such that the first sections of the at least two chairs are spaced apart.

According to a further broad aspect, there is provided a system of multiple chair comprising a chair adapted to stack, the chair comprising: a frame including a first section defining a first thickness; and a seating portion connected to the first section at an axis, the axis extending left to right on the chair in a width-wise direction, the axis being located between first and second surfaces of the seating portion; wherein at least part of the first surface and at least part of the second surface define two matching profiles which are curved; wherein a second thickness measured between the first and second surfaces is greater than the first thickness; and wherein a guard is connected to the first section and extends below a bottom of the first section at a distance corresponding to a difference between the first thickness and second thickness.

According to another broad aspect, there is provided a chair adapted to stack, comprising: a frame; a seating portion connected to the frame, wherein the seating portion is adapted about an axis parallel to a first plane, the axis being located between a first set of two profiles having matching curved shape, the first set of two profiles being defined by at least one cross section of the seating portion, the at least one cross section being located in a second plane perpendicular to the axis and the first plane and the first set of two profiles being located on first and second surfaces of the seating portion, one of the

first and second surfaces being a seating surface; a backrest portion connected to the frame; and a second set of two profiles of matching curved shape defined by at least one cross section of the backrest portion, the at least one cross section of the backrest portion being located in the second plane and the second set of two profiles being located on first and second surfaces of the backrest portion, wherein one of the first and second surfaces is a backrest surface, and wherein at least one of the seating or backrest surfaces is curved in the first plane; wherein the seating portion is adapted to rotate freely relative to the frame between first and second positions such that an angle of rotation between the first and second positions is greater than 90 degrees.

According to a further broad aspect, there is provided a system of multiple chairs, comprising: a first one of at least two chairs; and a second one of the at least two chairs; wherein the at least two chairs each comprises a frame comprising legs and a first section defining a first thickness, the legs supporting the first section; a seating portion; and a backrest portion, the seating portion connected to the first section at the first section of the frame, a width-wise axis passes through the first section and extends from left to right of the at least two chairs and is located between first and second surfaces of the seating portion wherein at least part of the first surface of the seating portion and at least part of the second surface of the seating portion define a first set of two matching profiles and the first surface of the seating portion is a seating surface, and a second thickness measured between the first and second surface of the seating portion is greater than the first thickness; and wherein the first one of the at least two chairs is adapted to stack on the second one of the at least two chairs such that the at least part of the second surface of the second one of the at least two chairs is in contact with the at least part of the first surface of the first one of the at least two chairs such that the first sections of the at least two chairs are spaced apart and the legs of the at least two chairs are spaced apart.

According to another broad aspect, there is provided a system of multiple chairs, comprising: a first one of at least two chairs; a second one of the at least two chairs; wherein the at least two chairs each comprises a frame comprising legs and a first section defining a first thickness, the legs supporting the first section; a seating portion; and a backrest portion, the seating portion connected to the first section at the first section of the frame, a width-wise axis passes through the first section and extends from left to right

of the at least two chairs and is located between first and second surfaces of the seating portion wherein at least part of the first surface of the seating portion and at least part of the second surface of the seating portion define a first set of two matching profiles and the first surface of the seating portion is a seating surface, and a second thickness measured between the first and second surface of the seating portion is greater than the first thickness; wherein the first one of the at least two chairs is adapted to stack on the second one of the at least two chairs such that the at least part of the second surface of the second one of the at least two chairs is in contact with the at least part of the first surface of the first one of the at least two chairs; and wherein the seating portion is adapted to move between open and closed positions, the open position being with the seating portion generally horizontal and the first and second ones of the at least two chairs stack together with the seating portion in the open configuration.

Variants, examples, preferred embodiments of the invention, and other objects of the invention and its particular features and advantages, will become more apparent from consideration of the following drawings and accompanying detailed description.

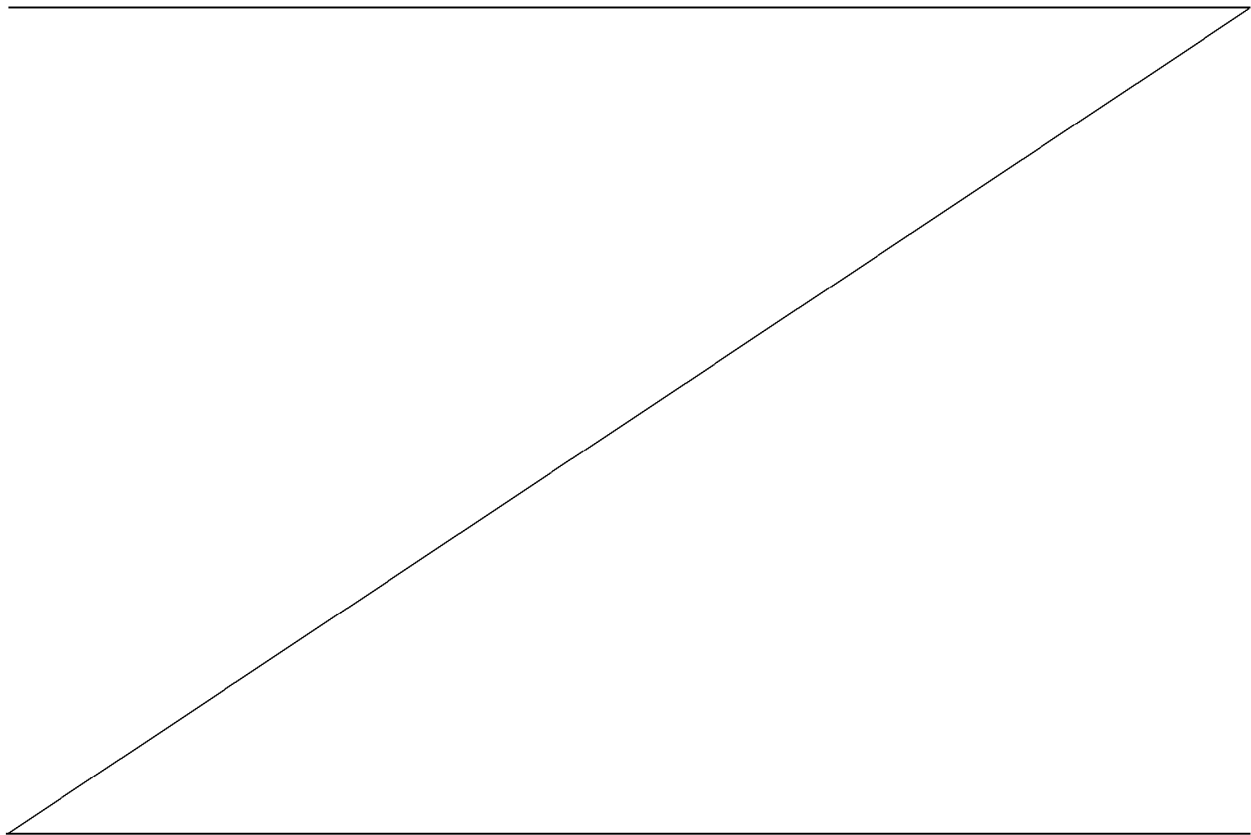

- 8 -

BRIEF DESCRIPTION OF THE DRAWINGS

[0031] FIG. 1 is a perspective view of a chair as disclosed herein.

[0032] FIG. 2 is a right side partial perspective view of the chair of FIG. 1.

[0033] FIG. 3 is a left side partial perspective view of the chair of FIG. 1.

[0034] FIG. 4 is a cutaway view of the chair of FIG. 1.

[0035] FIG. 5 is a front view of a row of chairs according to FIG. 1.

[0036] FIG. 6 is a top view of a row of chairs according to FIG. 1.

[0037] FIG. 7 is a side view of FIG. 1.

[0038] FIG. 8 is a section view of two chairs in FIG. 1 stacked with the section along line 8-8 of FIG. 10.

[0039] FIG. 9 is a section view of two chairs in FIG. 1 stacked with the section along line 9-9 of FIG. 10.

[0040] FIG. 10 is a perspective view of two chairs of FIG. 1 stacked and including a guard.

[0041] FIG. 11 is a side view of two chairs of FIG. 1 stacked on each other.

[0042] FIG. 12 is a side view of multiple chairs of FIG. 1 stacked on a trolley.

- 9 -

[0043] FIG. 13 is a perspective view of a frame piece for the chair of FIG. 1

[0044] FIG. 14 is a cross section view of FIG. 13

[0045] FIG. 15 is a cross section view of the backrest of the chair in FIG 1.

[0046] FIG. 16 is a detail cross section view of FIG. 15.

[0047] FIGS. 17-19 are perspective views of the guard for the chair of FIG. 1.

[0048] FIG. 20 is an exploded detail view showing the rotation and stop mechanism of the chair of FIG. 1.

[0049] FIG. 21 is a bottom perspective partial cutaway view of an alternate rotation and stop mechanism for the chair of FIG. 1.

DETAILED DESCRIPTION OF THE INVENTION

[0050] Referring now to the drawings, wherein like reference numerals designate corresponding structure throughout the views. The following examples are presented to further illustrate and explain the present invention and should not be taken as limiting in any regard.

[0051] Referring to Figure 1, an exemplary chair 2 is shown with a frame 4, a seating portion 6 and a backrest portion 8. The seating portion 6 is connected to the frame 4 at axis 22. Axis 22 passes between the seating portion 6 between top profile 10 and bottom profile 12. In some embodiments, the axis 22 passes through the seating portion 6 closer to profile 12 than profile 10. The first set of profiles 10/12 of the seating portion

- 10 -

6 having matching curves. Although profiles 10/12 are shown at the edge of the seat, it is understood that the profiles could be considered at any cross section across the seating surface and the cross sections may be taken perpendicular to the axis 22 or in other orientations. As shown, the profiles 10/12 are the same across the entire width of the seating portion. See plane 24' showing cross section 15 with matching top and bottom profiles. In the embodiment shown, profiles 10/12 are the same as the profiles of cross section 15.

[0052] It is contemplated that the profiles at edges 11/13 could be different than the profiles in the middle plane 24'. However, the top profile and the bottom profile will match in order to allow for the chairs to be supported across a relatively large surface when stacked. It is contemplated that the profiles 10/12 may not match entirely. For example, a middle section of bottom profile 12 may taper towards the front face 17 of the seating portion 6 such that less than 100% of the top 10 and bottom 12 profiles match. Where the profiles match, the seating surface 14 of one chair would contact bottom surface 19 of another chair when the chairs are stacked. Additional cross section examples are shown in Figs 10-12.

[0053] The backrest portion 8 of the chair 2 may have similar matching characteristics to the seating portion. As one example backrest surface 20 has a profile 16 that matches profile 18. As with the seating portion, the profiles of the backrest portion can change across the backrest in the direction of the axis 22 or the chair can be designed such that less than 100% of the profiles match. In one embodiment, the profiles 10/12 and/or 16/18 can be a section of a circle having a radius. The radius corresponding to profile 10 could be different than profile 16. It is understood that the radius of profile 10 would match the radius of profile 12 and the radius of profile 16 would match the radius of profile 18. The centers of the corresponding radii of the profiles

of two chairs when stacked may be spaced apart from each other at a distance corresponding to a thickness of the corresponding backrest/seating portion.

[0054] The backrest or seating portion or both may be curved in a plane that is perpendicular to plane 24.

[0055] Referring to Figs 8-10, other examples of cross sections and their corresponding profiles 180/160 and/or 180'/160' are shown. As can be seen in Fig. 8, profile 160 and profile 162 nest together such that a front surface of the backrest is in contact with a rear surface of the backrest of a second chair. In Fig. 9, profile 160' and profile 162' nest together such that a front surface of the backrest is in contact with a rear surface of the backrest of a second chair.

[0056] In Figs 2 and 3, the chair 2 is shown with a single sided arm configuration. The arm 38 in this example is attached to the right side of the chair and securing member 42 extends from the base of the arm near the frame. A female securing member 40 is on the opposite (left) side of the chair and includes channel 44 that receives securing member 42 and the chair is built without an arm on the opposite (left) side, however the chair could be built with two arms. The securing member as shown has an intermediate diameter/size that fits in the channel 44 and end 43 is larger than the opening in the channel and fits between the side 41 of the backrest and the inner surface of the securing member 40 that faces the side 41. The securing member is typically inserted into the channel 44 from top to bottom, but the reverse assembly configuration is contemplated as well. The chair 2 can also be built with no arms and still use the securing system shown and described herein.

[0057] In Fig. 4, additional detail regarding the inner structure of the seating and backrest portions is shown. The backrest portion includes support wires 48 and an-internal frame 49/58. Foam 46 is molded around the internal frame and wires to create the padding for the backrest. The foam 46 may be injection molded. For examples of injection molded seating elements with internal frames, see U.S. 7,690,732. Frame piece/channel 58 may be partially exposed in order to allow for

attachment of the seat cover 44 as more fully shown and described with reference to Figs 13-16.

[0058] As also shown in Fig. 4 the seating portion may include an inner frame 50 a webbing 52 or other support structure/member, injection molded foam 54 and cover 56. At the rear of the frame is weight 51. This weight induces rotation of the seat when a user stands up and allows the seat to rotate freely. As also shown, more foam 54 is on the top side of the frame 50 than on the bottom. This causes a rotational instability that allows the seating portion to rotate past 90 degrees as shown and described in reference to Fig. 7.

[0059] In Fig. 5, three chairs are shown aligned in a row. Although not shown, it is contemplated that end chair 2' could include two arms with the remaining chairs including a single arm as described previously. In the top view shown in Fig. 6, the inner edge 98 of the arm of chair 2' is shown spaced apart from outer edge 100 of the first portion of the frame. The distance 95 is preferably larger than the width 97 of the rear leg. This allows for sufficient space during stacking. Also, since the chairs are configured with single arms and the legs insert between the arm and the frame, the use of a single arm also saves a considerable amount of space. As one example, distance 94 may be approximately 4 inches. If each chair had two arms, an additional 4 inches per seat would be needed. With rows of 20 seats, an additional 80 inches is provided, which could accommodate two or more additional chairs per row. The spacing 95 may also be in reference to guard 34 which is not shown in Fig 6.

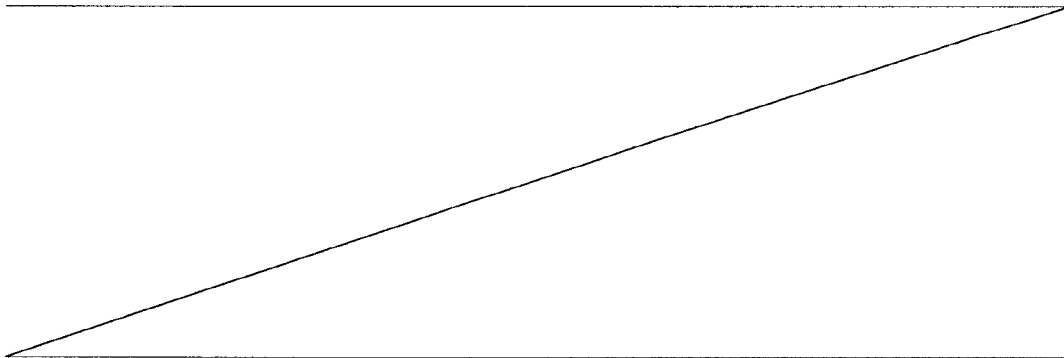

- 13 -

[0060] Referring to Fig 7, the seating portion is shown in first position 102, which would be the position where someone is sitting on the chair. When weight is removed from the chair, the seating portion will rotate 101 towards position 106 and through position 104. Also shown is rotational equilibrium position 108 of the seating portion relative to axis 22. This position 108 is due to the weight 51 being positioned above axis 22 in position 102 and more foam being positioned above the inner frame 50 than below and the positioning of axis 22 relative to the seating portion. This causes the seat to have a tendency to move towards position 108, however the seating portion stops at position 106 due to contact with the backrest portion. The rotation shown in Fig. 7 is due to weighting without other mechanical forces such as springs or elastic materials or motors.

[0061] In Figs. 8-10, additional cross sections are shown in the example of two stacked chairs to show how various profiles match and nest when chairs are stacked. For example, profiles 180 and 160 match and profiles 162 and 160 nest together when stacked. Referring to Fig. 9, the vertical profiles 162'/160'/180' may be a radius of a circle since when the chairs stack, the backrest and seating portions are slightly offset with respect to each other. Since the profiles are a constant radius, there is consistent contact between the respective surfaces to distribute weight of the chairs across a relatively large surface.

[0062] In Fig. 11, two chairs are shown stacked together. As shown, the thickness 72 of the seating portion is larger than the thickness 70 of the first portion of the frame. This causes the bottom of the first portion of the top chair to be spaced apart at a distance 74 from the top of the first portion of the bottom chair. Distance 74 in this case is equal to the difference between distance 72 and 70. Also shown is thickness 76 of the backrest is greater than thickness 78 of the leg.

- 14 -

[0063] In some cases a large number of chairs, possibly up to 16 or more (depending on the thickness of the seating/backrest portions) may be stacked in the horizontal configuration show in Fig. 11 with the center of gravity of the stack still between the bases of the legs. This may prevent the stack from toppling/rotating over around the front leg in storage without the dolly shown in Fig. 12.

[0064] In Fig. 12, twenty-seven (27) chairs are shown stacked together. As can be seen the profiles of each chair match. In the configuration shown, the profiles are sections of a circle, which allows the chairs to nest such that the front faces of the seating portions are offset slightly with respect to each other. As can also be seen, the chairs stack vertically such that the center of gravity of each chair and the center of gravity of the stack aligns along axis 80. As shown, axis 80 is located between wheels of the dolly 86. In the example shown, distance 88 is 80 inches or slightly smaller in order to accommodate a door frame height of 80 inches and fit 21 chairs therein. As also shown, 22 chairs fit within 84 inches (distance 90) and 27 chairs fit within 96 inches (distance 92).

[0065] Figs 13-16 show a chair covering system. Channel 58 is connected to the frame as previously shown. This channel 58 includes two inwardly turned ribs 60. The cover 44 includes loops at the open end. The loops may be formed by sewing 66 an end of the fabric of the cover 44 on an intermediate portion of the fabric of the cover 44. To install the chair, C-shaped elongated clips 62 are inserted into the loops and clipped over the inwardly turned ribs 60. The C-shaped clips are shown rounded but could include or be made entirely of straight sections. The cover 44 is placed under tension and the clips engage against the rib 60 such that portions 65/70 are between the clip 62 and the rib 60. To remove the cover, the cover 44 is pulled down and the clips 62 are removed from the ribs 60 to release the cover 44 from the channel 58. The cover 44 may have holes therein that align

- 15 -

with the arm 38 and the female securing member 44 when the cover is inserted over the backrest such that these parts can be bolted/secured after covering.

[0066] The guard 34 is shown in FIGS 17-19. This guard includes top 300 and bottom 302 surfaces that are spaced apart a distance that allows for the guard to fit between the first portions 32 of the chairs when stacked. Channel 306 allows stop 200 to rotate therein when the seating surface is folded to position 106. Channel 304 of the guard 34 fits around the first portion 32 and the lower portion below the guard is of a size slightly less than than distance 74. For example, the sum of the thicknesses of the lower section below the channel 304 and the upper portion above the channel 304 may be equal to distance 74. The upper 300 and lower surfaces 302 may also be curved and can have matching profiles in order to allow for nesting of the guards in addition to nesting of the seating surfaces. The guard may be formed out of a plastic or rubber material.

[0067] In Fig 20, the seating stop 200 is shown and interacts with stop 204 in position 102 when weight is on the seating surface (someone sitting on the chair). Pivot 202 rotates with respect to the frame to allow the seating portion to rotate relative to the frame.

[0068] In Fig. 21, the seating stop 200' includes a threaded cylinder 203' that is shown passing through a hole in the seat frame. The cylinder 203' may be welded to the seat frame. Threaded rod 201' threads into the cylinder and section 205' close to the threads may be of a diameter larger than that of the outer threads. This reduces bending stresses on the threads, which would be apt to break in bending due to stress concentrations if the cylinder 203' was not used. Stop 204' is formed as a channel in first portion 32'. As shown, portion 32' is solid 320 and is welded to hollow leg 30. Rotation mechanism 206'/202' is shown to allow the seating portion to rotate relative to

- 16 -

the frame. The outer portion 206' may be fixed relative to the frame and inner portion 202' may rotate therein. In other aspects, outer portion 206' may rotate relative to the frame and 202' may allow for removal of the seating portion from the frame. Cover 56' is shown very close to portion 32', and foam 54' may partially surround seating stop 200' and rotation mechanism 206'/202'. By placing the stop 204' in the portion 32' of the frame, stop 204 is not needed and there may be a savings space on each side of the seating portion. This space savings may be $\frac{1}{4}$ inch on each side which would allow the seating portion to be wider by approximately $\frac{1}{2}$ inch. This may provide added comfort to the user.

[0069] Although the invention has been described with reference to a particular arrangement of parts, features and the like, these are not intended to exhaust all possible arrangements or features, and indeed many other modifications and variations will be ascertainable to those of skill in the art.

CLAIMS

1. A chair adapted to stack, comprising:

a frame;

a seating portion connected to the frame, wherein the seating portion rotates about an axis parallel to a first plane, the axis being located between a first set of two profiles having matching curved shape, the first set of two profiles being defined by at least one cross section of the seating portion, the at least one cross section being located in a second plane perpendicular to the axis and the first plane and the first set of two profiles being located on first and second surfaces of the seating portion, one of the first and second surfaces being a seating surface;

a backrest portion connected to the frame so that the backrest portion is in a fixed vertical position; and

a second set of two profiles of matching curved shape defined by at least one cross section of the backrest portion, the at least one cross section of the backrest portion being located in the second plane and the second set of two profiles being located on first and second surfaces of the backrest portion, wherein one of the first and second surfaces is a backrest surface, and wherein at least one of the seating or backrest surfaces is curved in the first plane.

2. The chair of claim 1, wherein at least one profile of the first or second sets of two profiles corresponds to at least 50% of the corresponding seating or backrest surfaces across the corresponding seating or backrest in a direction of the axis.

3. The chair of claim 1, wherein at least one profile of the first or second sets of two profiles corresponds to at least 75% of the corresponding seating or backrest surfaces across the corresponding seating or backrest surfaces in a direction of the axis.

4. The chair of any one of claims 1 to 3, wherein the seating portion is adapted to rotate freely relative to the frame between first and second positions such that an angle of rotation between the first and second positions is greater than 90 degrees.

5. The chair of any one of claims 1 to 4, comprising an interior cavity of the seating or backrest portion comprising an internal frame and a compressible padding material injection molded around the internal frame.

6. The chair of claim 1, wherein the seating portion rotates between first and second positions such that an angle of rotation between the first and second positions is greater than 90 degrees and wherein rotation from the first position towards the second position moves the seating portion towards a rotational equilibrium is caused by weight imbalance of the seating portion in the first position relative to the rotation axis such that the seating portion moves an end of the seating element past a vertical axis, the vertical axis passing through the rotation axis.

7. The chair of claim 6, comprising a front leg section of the frame extending along a leg axis wherein in the second position, the seating portion aligns parallel to the leg axis.

8. The chair of claim 7, comprising a rotational equilibrium position of the seating portion defined where the seating portion is balanced about the axis of rotation, the rotational equilibrium position located at an angle relative to the first position, the angle greater than the angle of rotation.

9. The chair of claim 8, wherein the backrest portion is connected to the frame for preventing rotation of the seating portion beyond the angle of rotation.

10. The chair of claim 1, comprising at least one channel connected to the frame and having at least one inwardly turned rib and an inner void, a cover having an open end and two sides, the open end being adapted to receive a backrest support; a section of the open end defining an elongated loop extending in a direction between the two sides; and a C-shaped elongated member adapted to insert into the elongated loop such that the rib is positioned between two parts of the elongated loop and the two parts are clamped within the C-shaped elongated member to secure the cover to the frame.

11. The chair of claim 10, wherein the seating portion is connected to the frame portion and wherein the backrest portion comprises the backrest support, each of the seating and backrest portions defining first and second surfaces, the first surface of the seating portion being a seating surface, a cross section of the seating portion and a cross section of the backrest portion each defining two matching profiles corresponding to at least part of the first and second surfaces, and wherein at least one pair of the two matching profiles is curved.

12. The chair of claim 11, wherein the axis is located between the first and second surfaces of the seating portion.

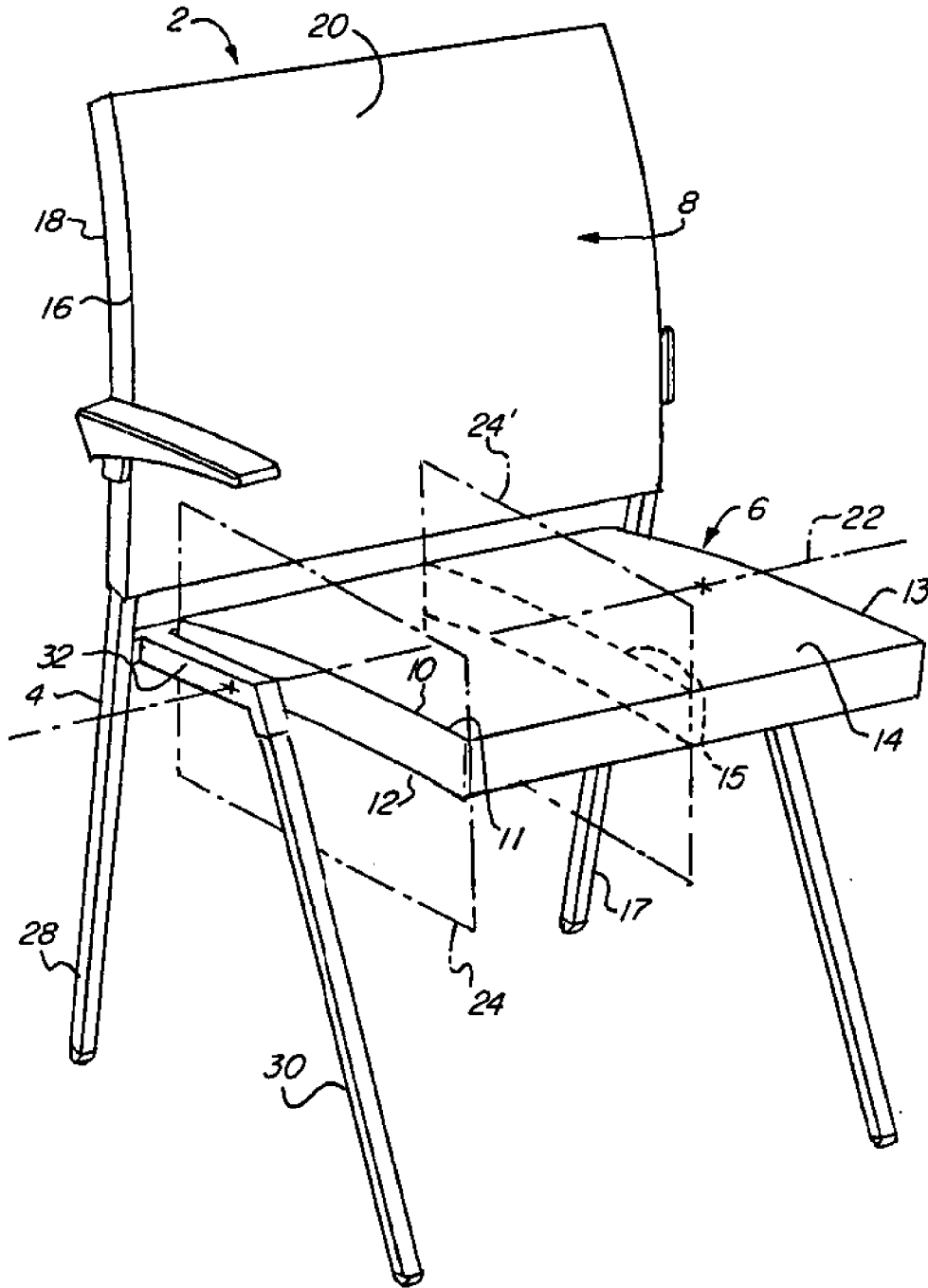

FIG. 1

2/13

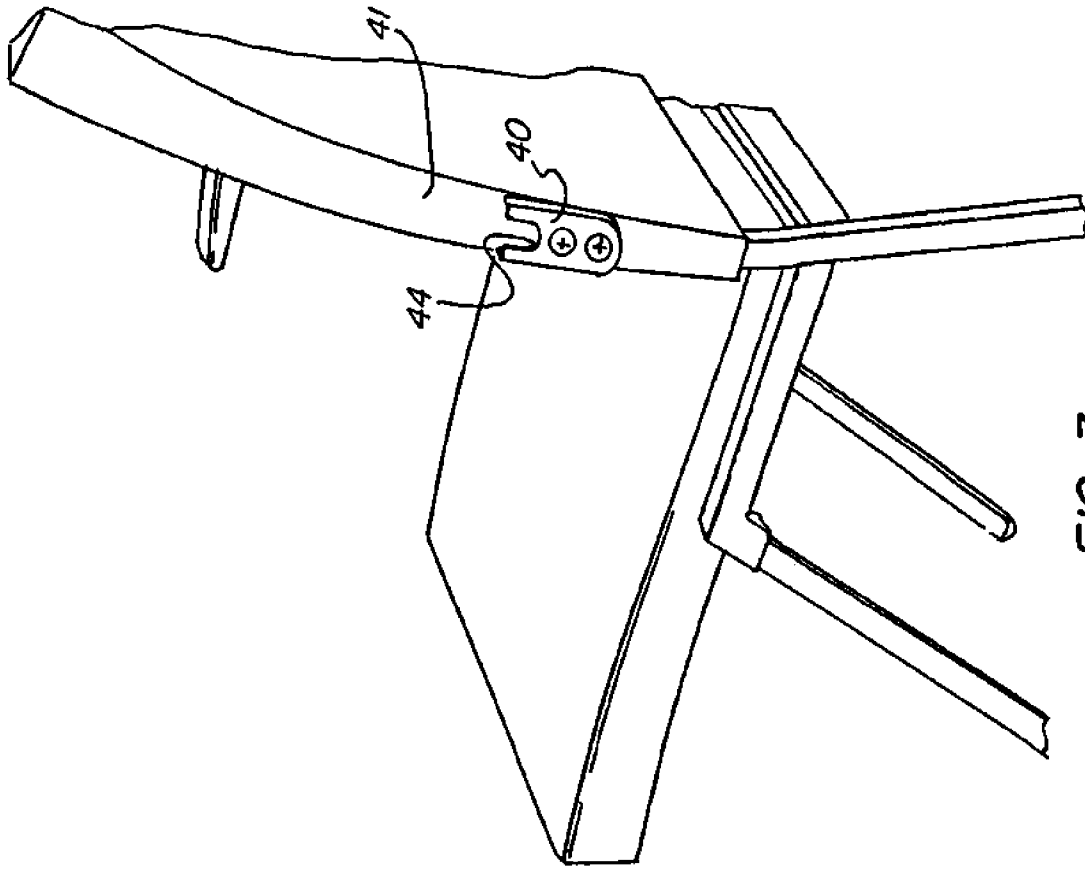

FIG. 3

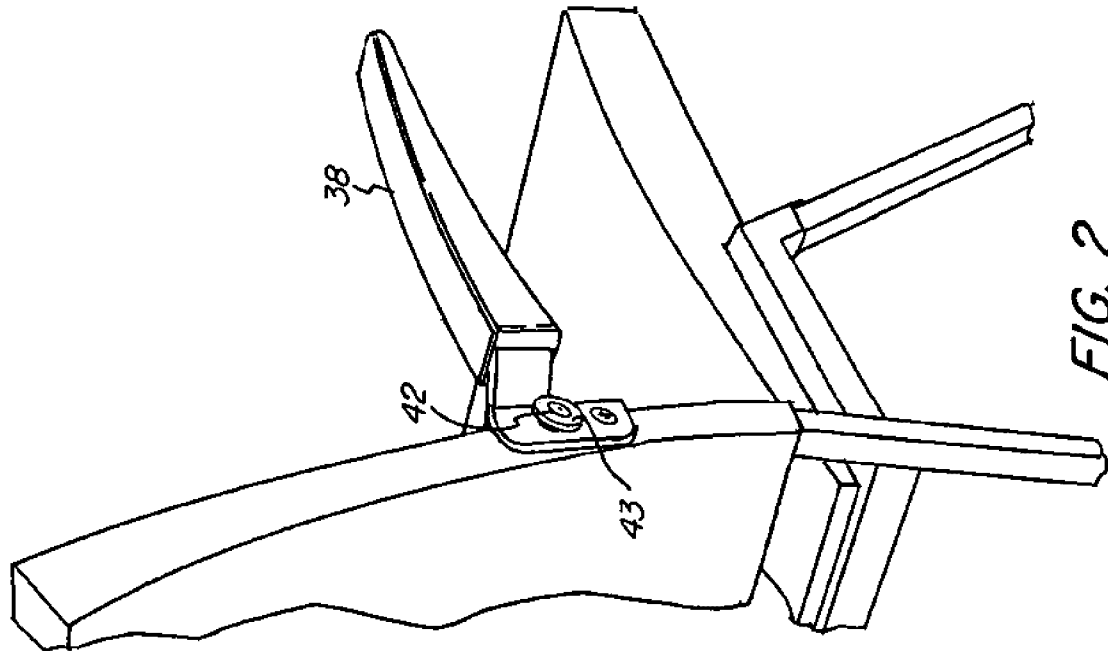

FIG. 2

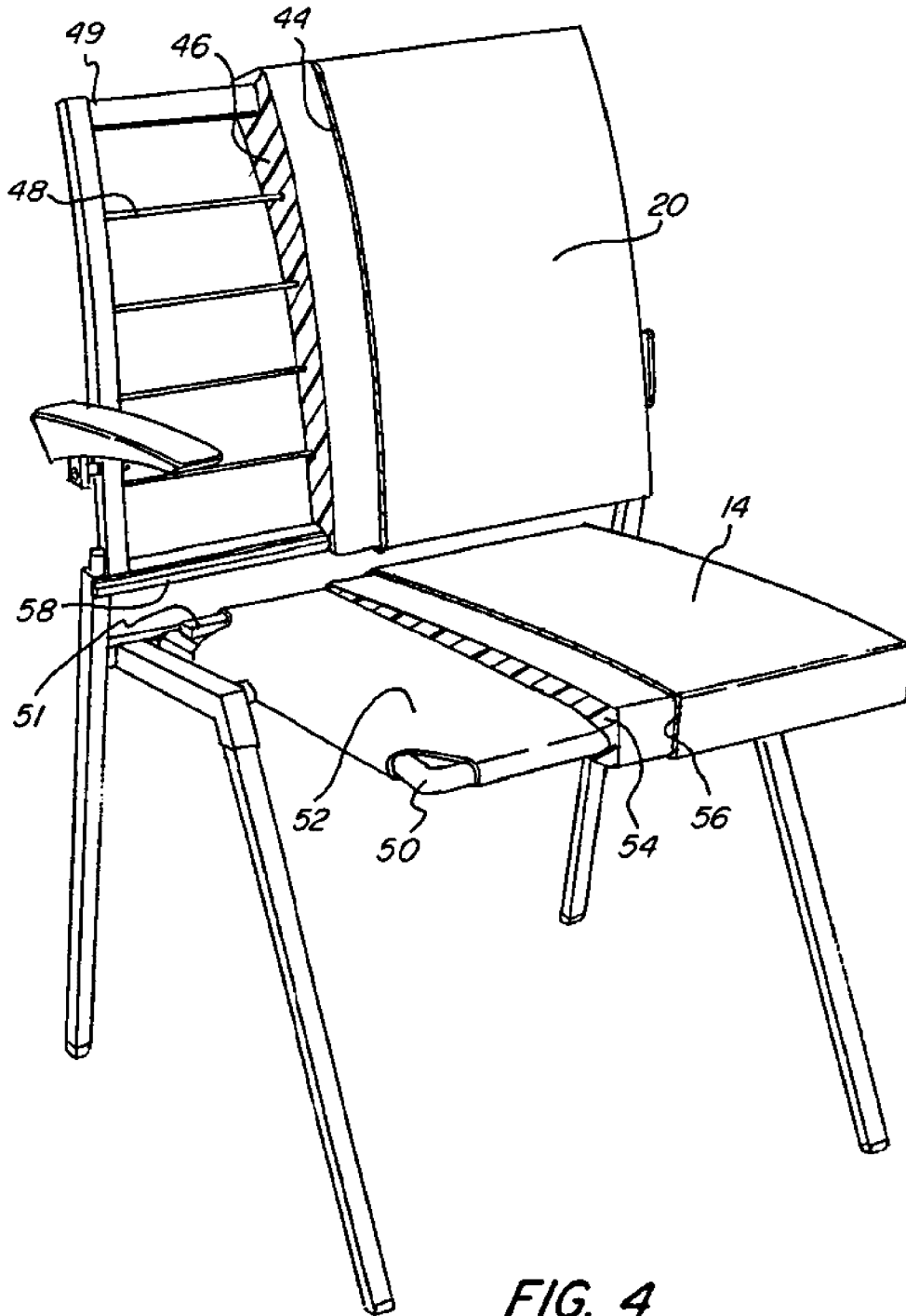
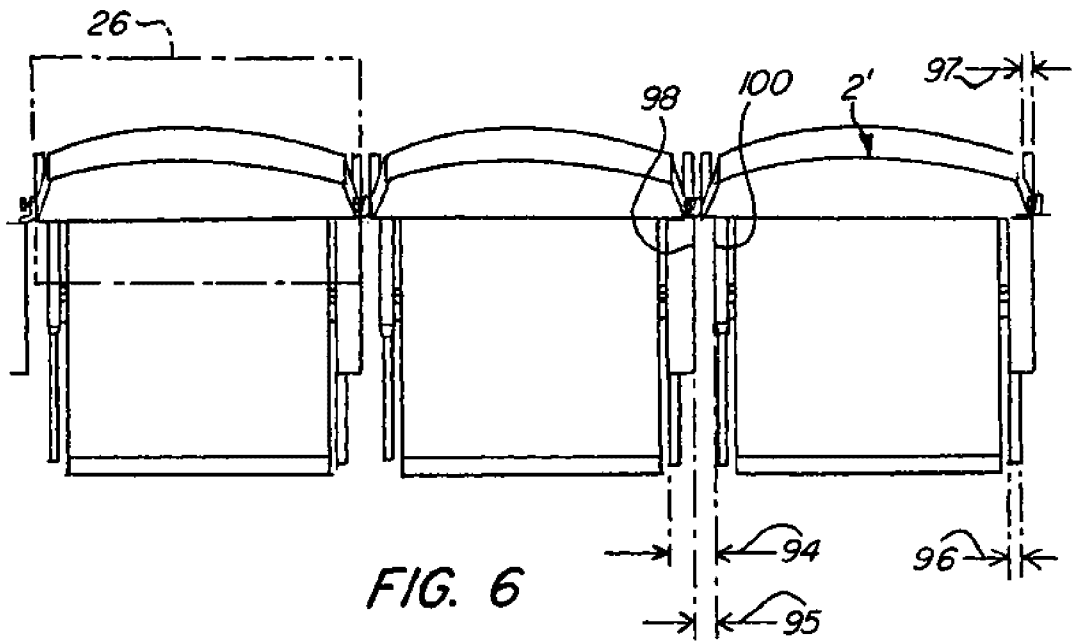
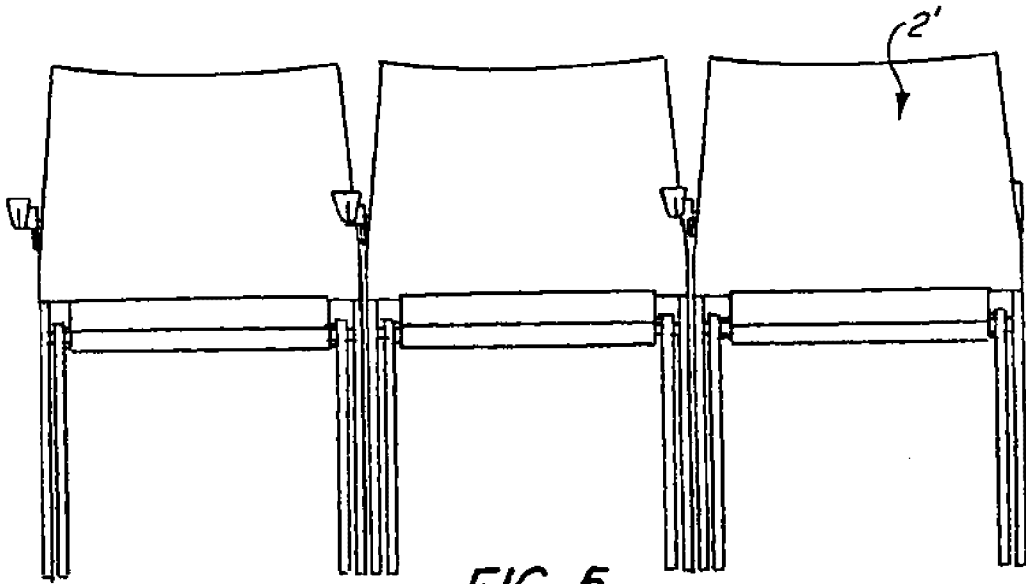

FIG. 4



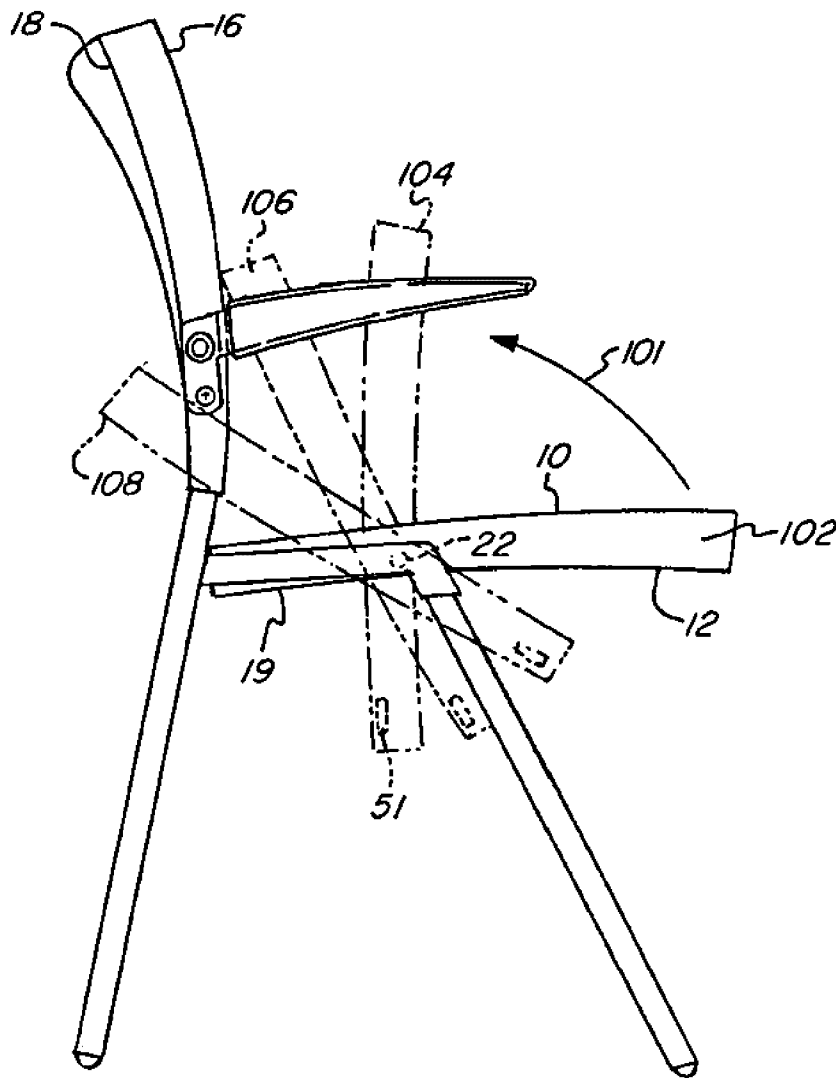

FIG. 7

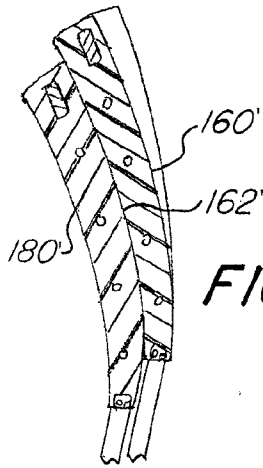

FIG. 9

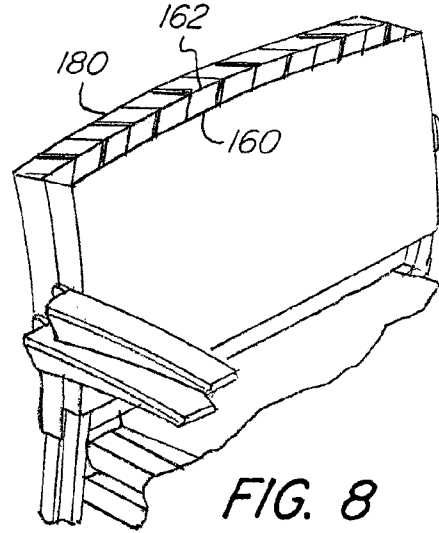

FIG. 8

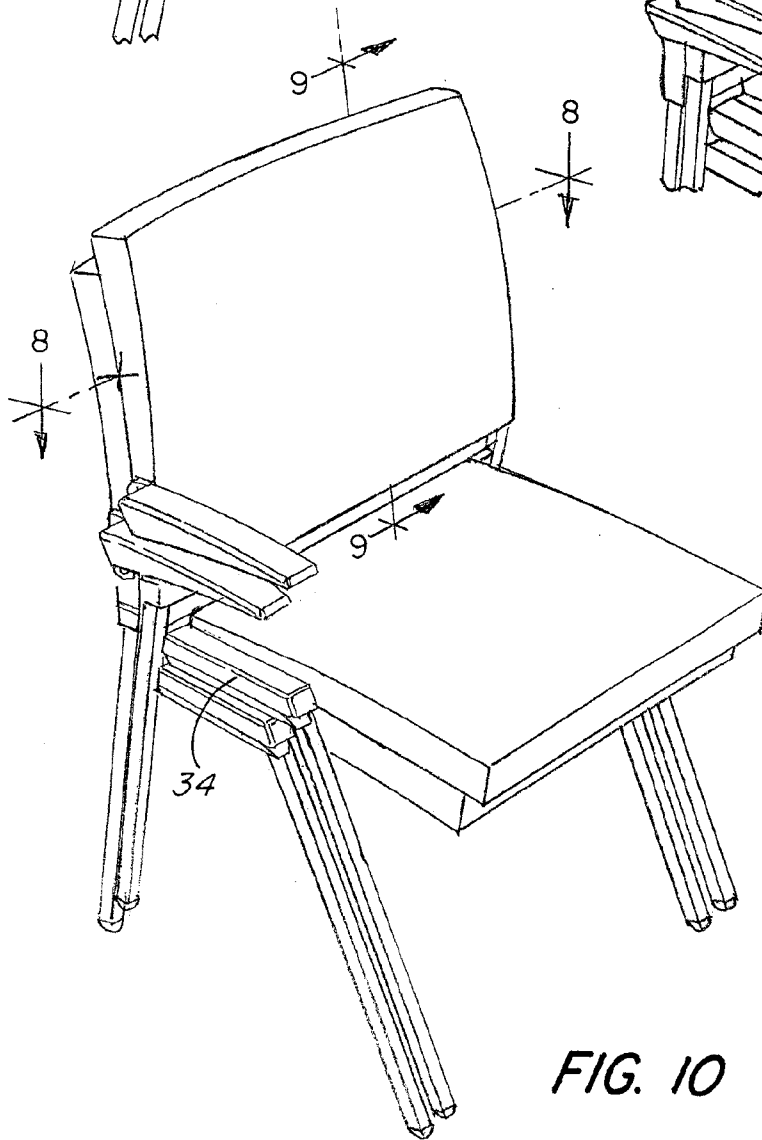

FIG. 10

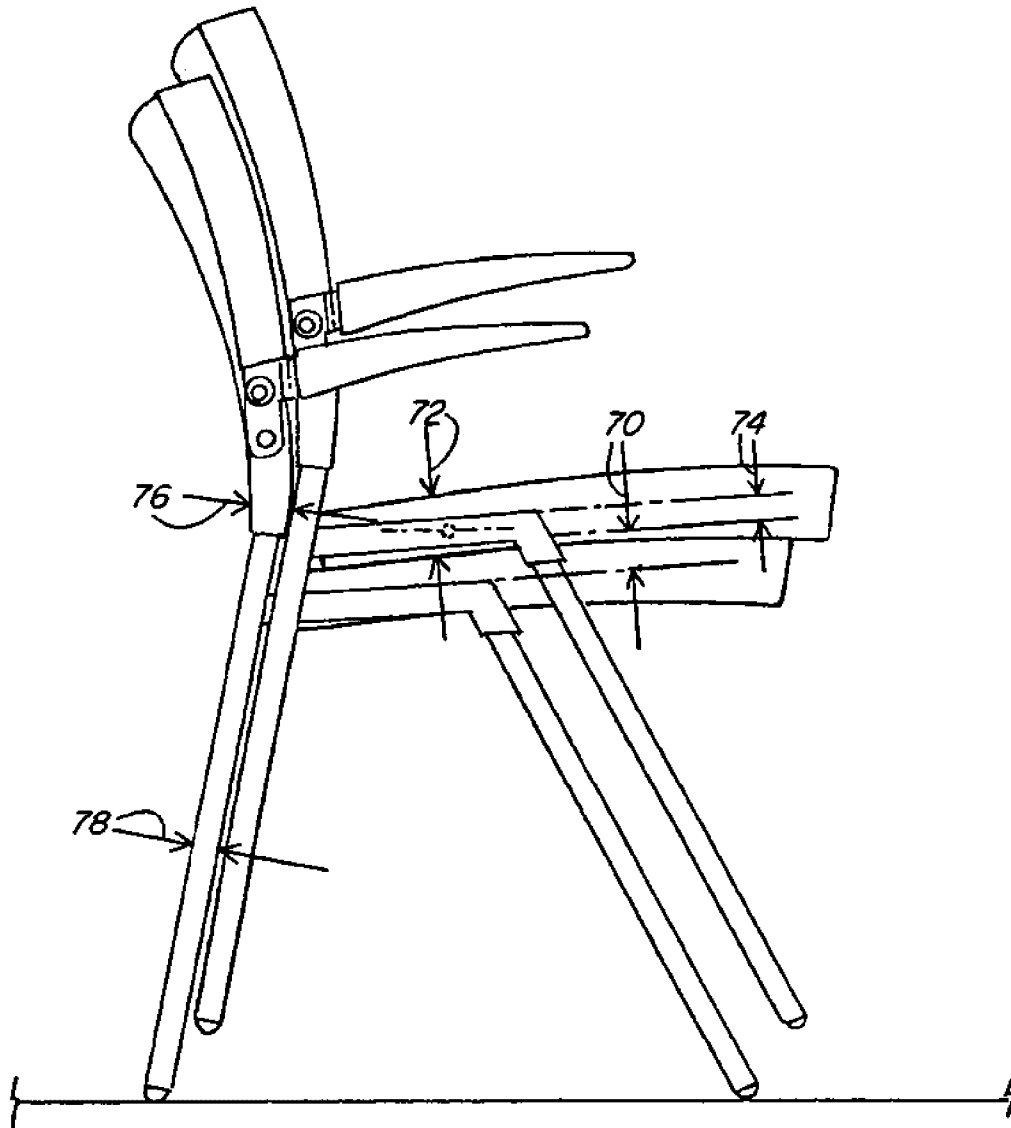
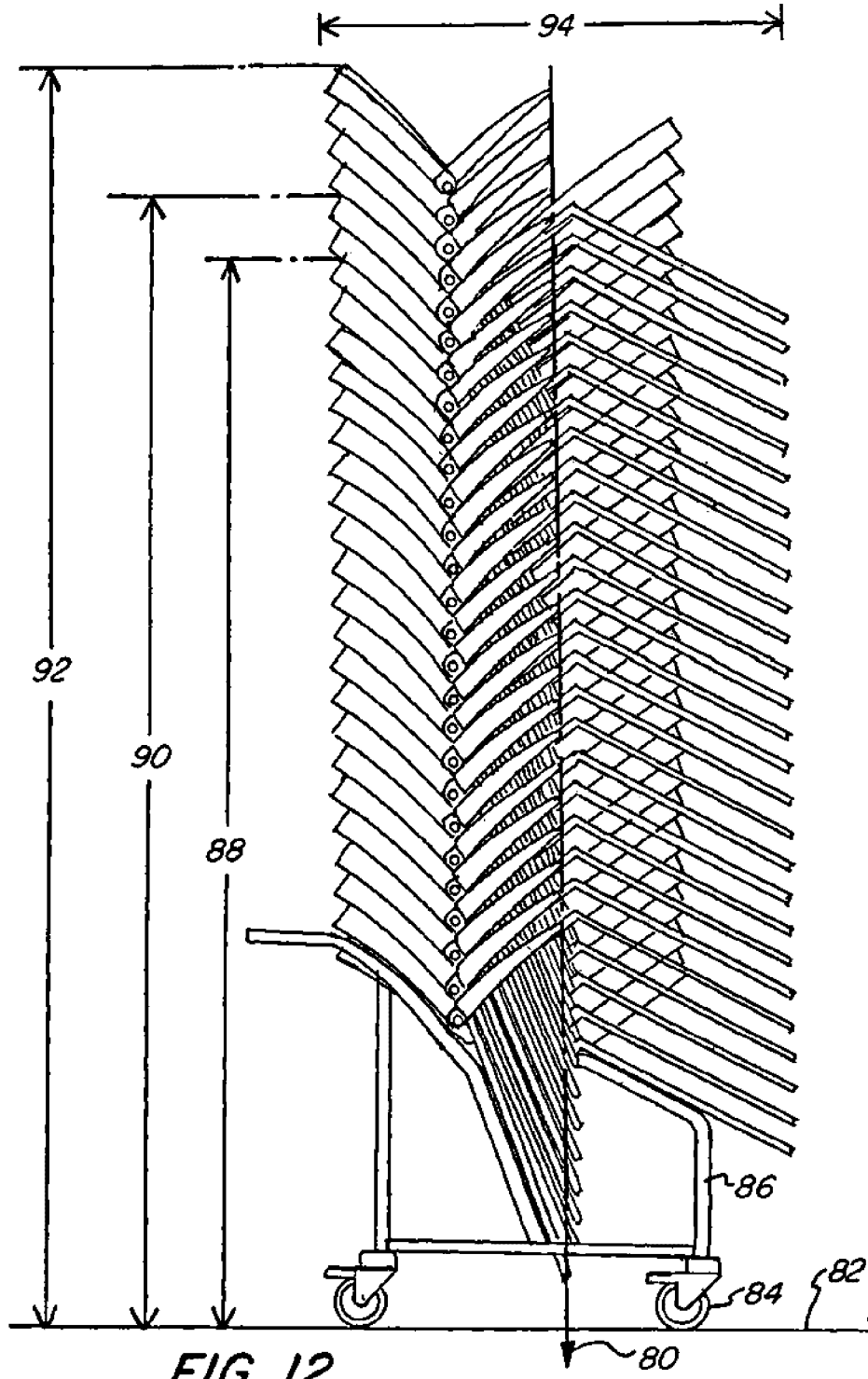
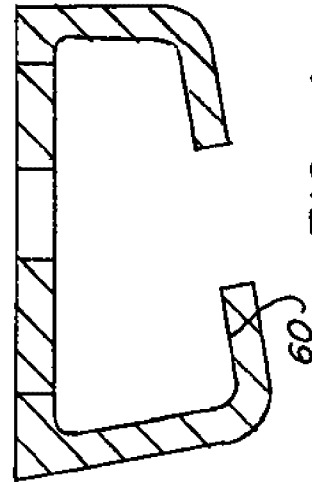
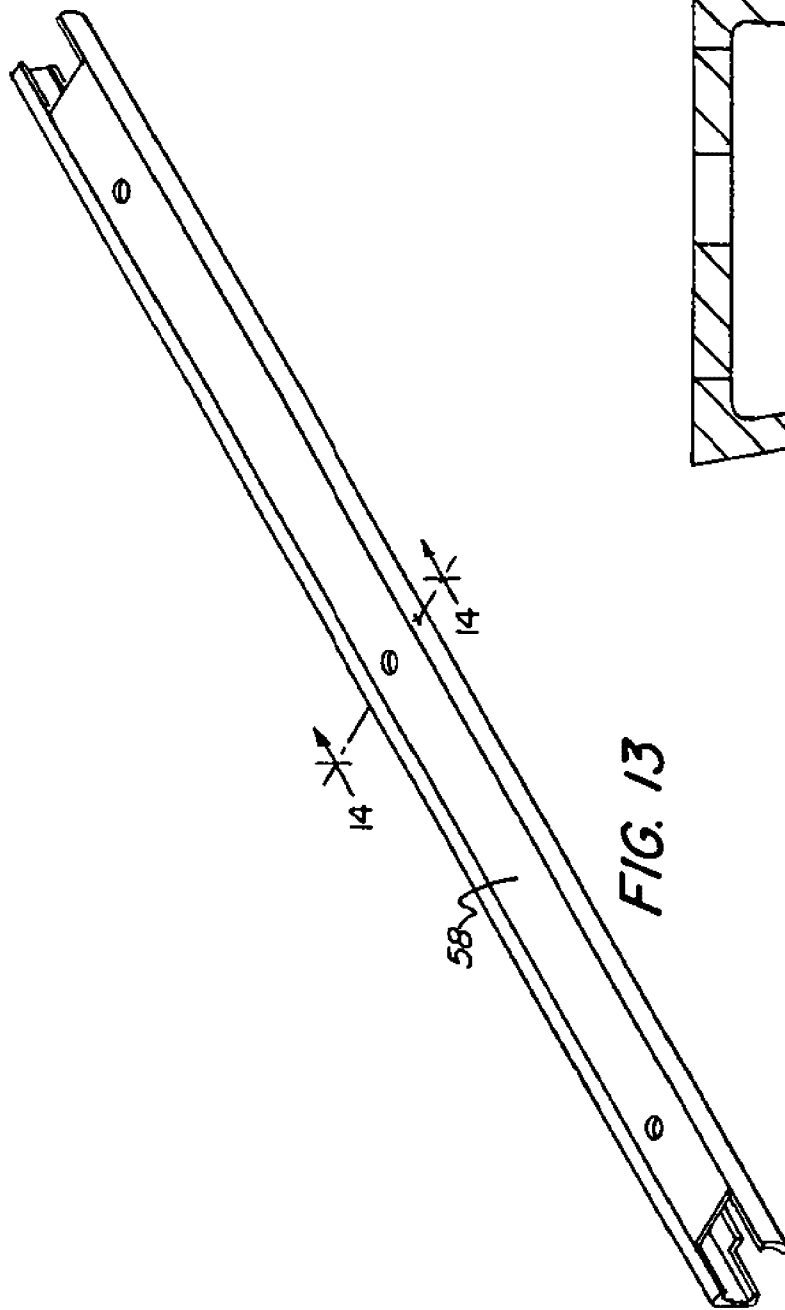
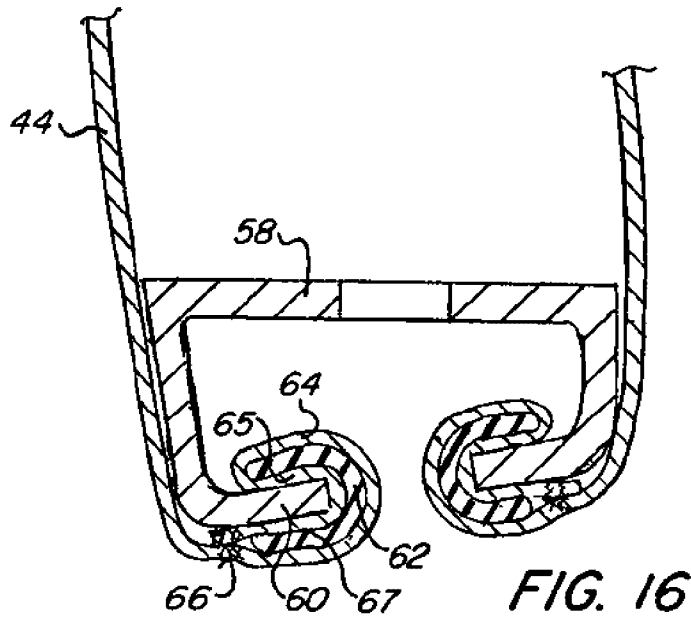
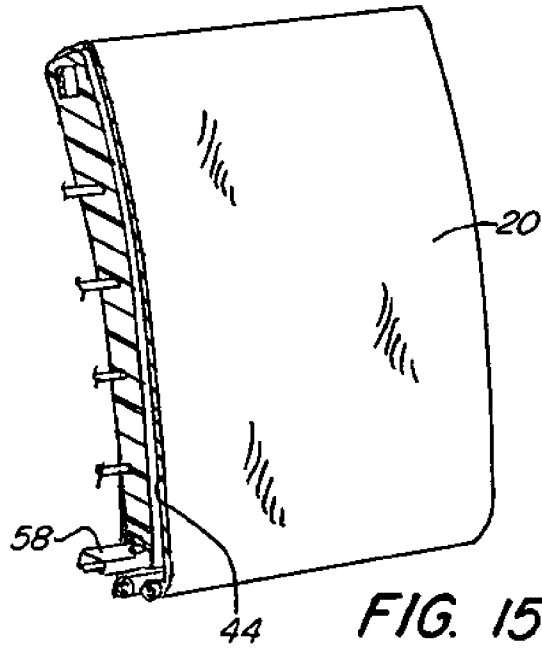

FIG. 11





10/13



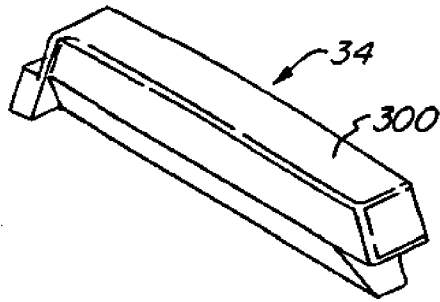

FIG. 17

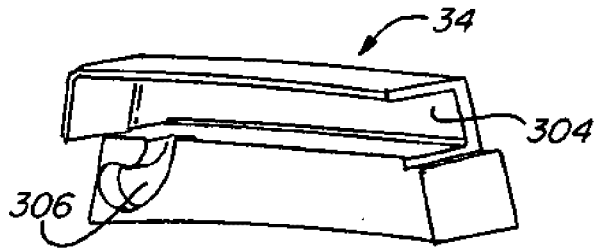

FIG. 18

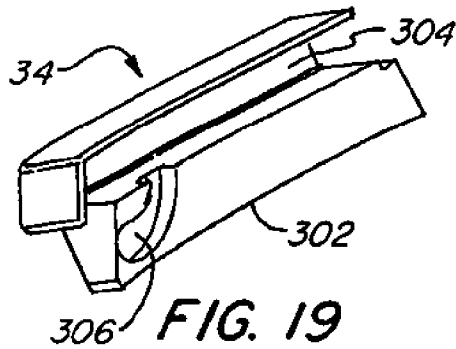

FIG. 19

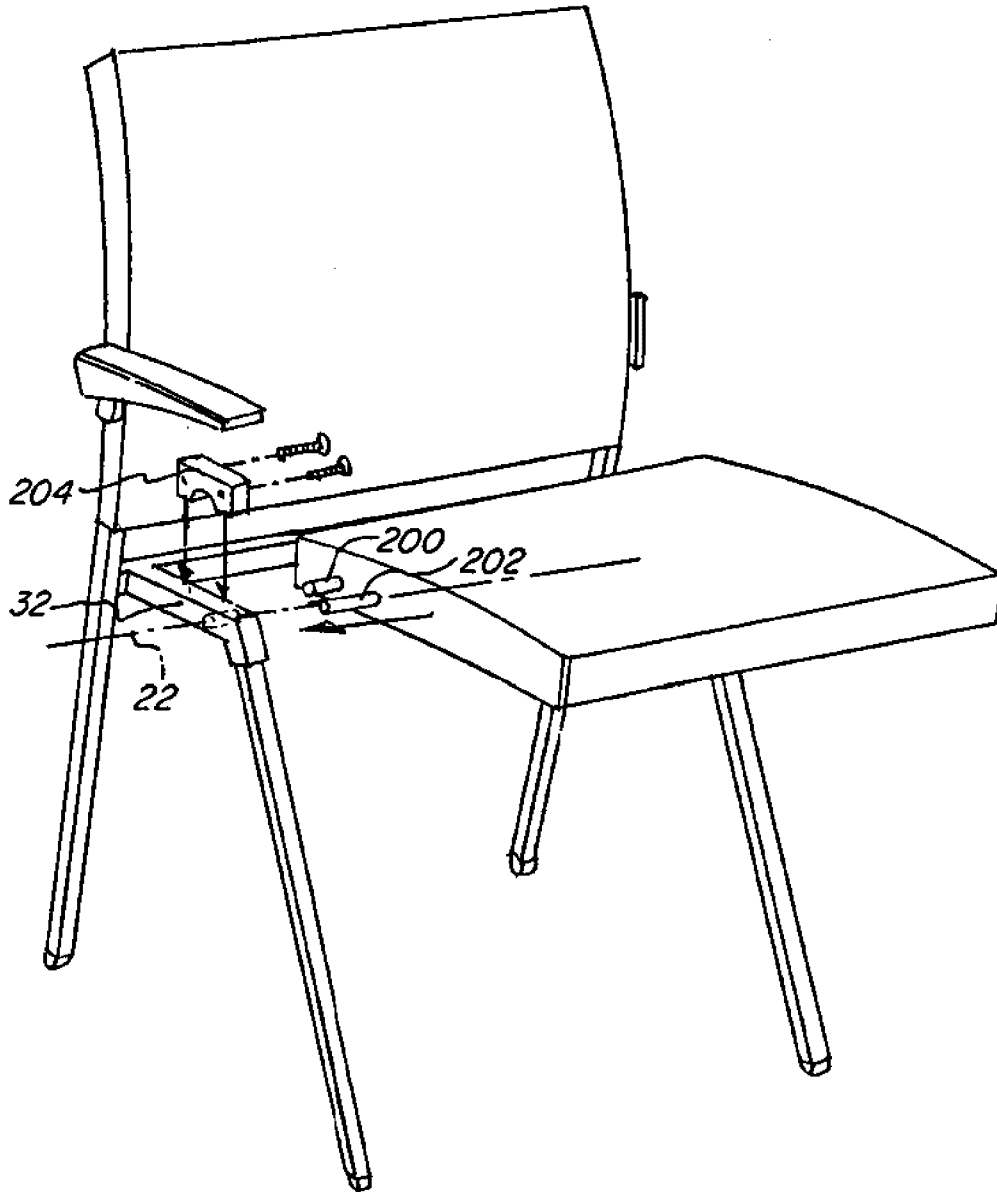

FIG. 20

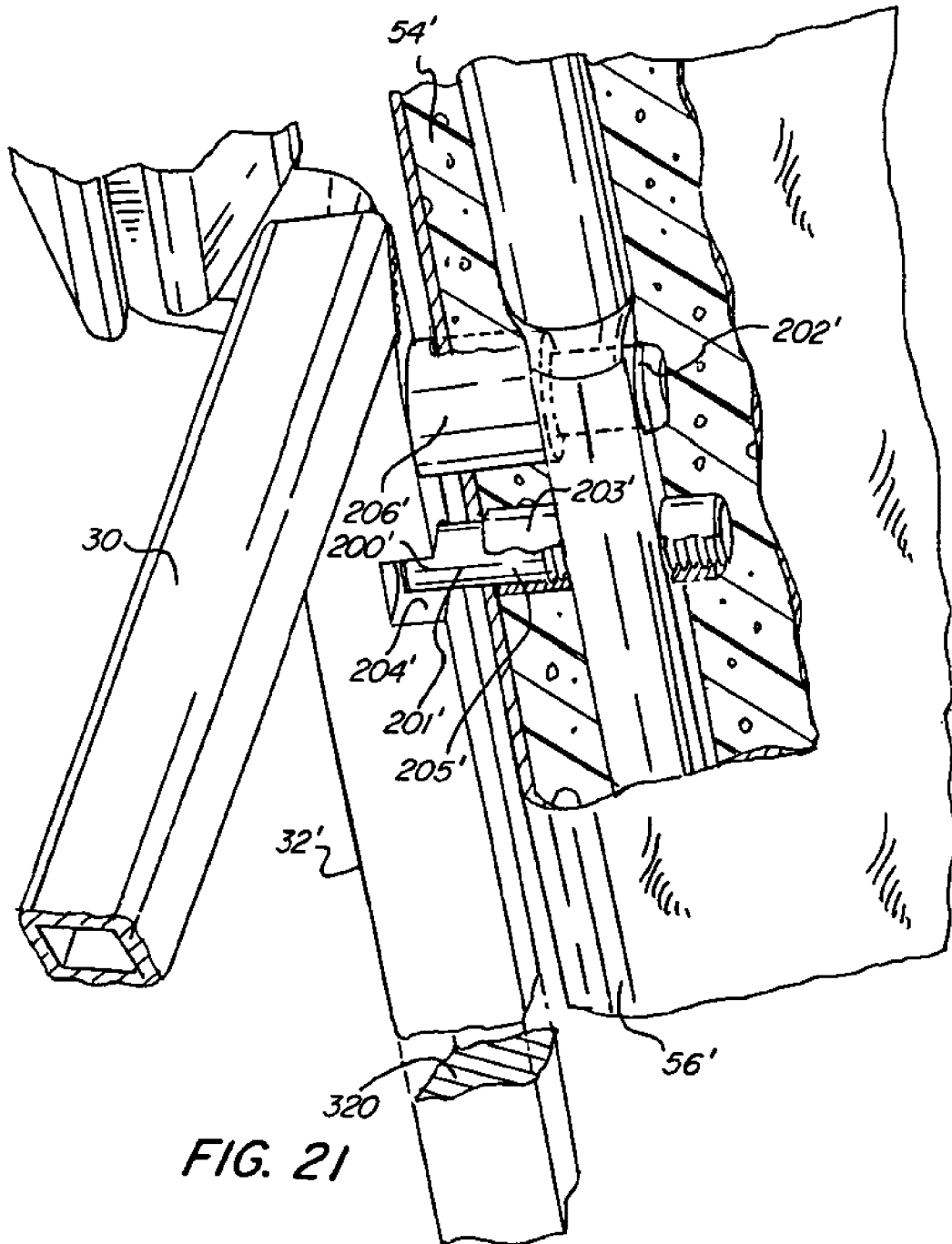

FIG. 21

