



(43) International Publication Date
29 September 2016 (29.09.2016)

- (51) International Patent Classification:
E21B 6/02 (2006.01) E21B 4/10 (2006.01)
- (21) International Application Number:
PCT/CA2016/000082
- (22) International Filing Date:
24 March 2016 (24.03.2016)
- (25) Filing Language: English
- (26) Publication Language: English
- (30) Priority Data:
62/137,863 25 March 2015 (25.03.2015) US
- (71) Applicant: DRECO ENERGY SERVICES ULC
[CA/CA]; 2900 Manulife Place, 10180 - 101 Street, Ed-
monton, Alberta T5J 3V5 (CA).
- (72) Inventors: SHEEHAN, Mark; 8907 - 7th Avenue SW,
Edmonton, Alberta T6X 1B9 (CA). PRILL, Jonathan;
7603 -16 Avenue SW, Edmonton, Alberta T6X 1M3 (CA).
- (74) Agent: TOMKINS, Donald V.; c/o Tomkins Law Office,
740, 10150 - 100 Street, Edmonton, Alberta T5J 0P6 (CA).
- (81) Designated States (unless otherwise indicated, for every
kind of national protection available): AE, AG, AL, AM,
AO, AT, AU, AZ, BA, BB, BG, BH, BN, BR, BW, BY,
BZ, CA, CH, CL, CN, CO, CR, CU, CZ, DE, DK, DM,
DO, DZ, EC, EE, EG, ES, FI, GB, GD, GE, GH, GM, GT,

HN, HR, HU, ID, IL, IN, IR, IS, JP, KE, KG, KN, KP, KR,
KZ, LA, LC, LK, LR, LS, LU, LY, MA, MD, ME, MG,
MK, MN, MW, MX, MY, MZ, NA, NG, NI, NO, NZ, OM,
PA, PE, PG, PH, PL, PT, QA, RO, RS, RU, RW, SA, SC,
SD, SE, SG, SK, SL, SM, ST, SV, SY, TH, TJ, TM, TN,
TR, TT, TZ, UA, UG, US, UZ, VC, VN, ZA, ZM, ZW.

(84) Designated States (unless otherwise indicated, for every
kind of regional protection available): ARIPO (BW, GH,
GM, KE, LR, LS, MW, MZ, NA, RW, SD, SL, ST, SZ,
TZ, UG, ZM, ZW), Eurasian (AM, AZ, BY, KG, KZ, RU,
TJ, TM), European (AL, AT, BE, BG, CH, CY, CZ, DE,
DK, EE, ES, FI, FR, GB, GR, HR, HU, IE, IS, IT, LT, LU,
LV, MC, MK, MT, NL, NO, PL, PT, RO, RS, SE, SI, SK,
SM, TR), OAPI (BF, BJ, CF, CG, CI, CM, GA, GN, GQ,
GW, KM, ML, MR, NE, SN, TD, TG).

Declarations under Rule 4.17:

- as to applicant's entitlement to apply for and be granted a
patent (Rule 4.17(ii))
- as to the applicant's entitlement to claim the priority of the
earlier application (Rule 4.17(iii))
- of inventorship (Rule 4.17(iv))

Published:

- with international search report (Art. 21(3))

(54) Title: IMPACT-DRIVEN DOWNHOLE MOTORS

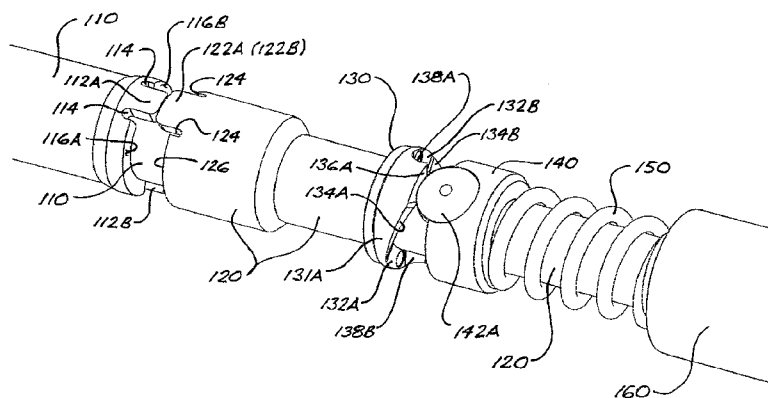

FIG. 2A

(57) Abstract: A downhole motor has a bearing mandrel rotatably disposed within a housing, plus an impact adapter disposed above and connected to the bearing mandrel and rotatable therewith. The impact adapter has upwardly-projecting teeth engageable with downwardly-projecting teeth on a drive mandrel disposed above and coaxially aligned with the impact adapter. The drive mandrel is both rotatable and axially movable within the housing, and relative to the impact adapter. By means of a cam assembly and a helical spring (or other energy storage means) associated with the drive mandrel, rotation of the drive mandrel causes upward movement of the drive mandrel within the housing, thus compressing the spring. Further rotation causes instantaneous dropping of the drive mandrel, releasing energy stored in the spring, and causing the application of rotational and/or axial impacts to the bearing mandrel, and thus to a drill bit connected to the bearing mandrel.



IMPACT-DRIVEN DOWNHOLE MOTORS

FIELD

5 The present disclosure relates in general to downhole motors used for drilling oil, gas, and water wells, and relates in particular to drive systems incorporated into such downhole motors.

BACKGROUND

10 In drilling a wellbore into the earth, such as for the recovery of hydrocarbons or minerals from a subsurface formation, it is conventional practice to connect a drill bit to the lower end of an assembly of drill pipe sections connected end-to-end (commonly referred to as a “drill string”), and then to rotate the drill string so that the drill bit progresses downward into the earth to create the desired wellbore. In conventional vertical wellbore drilling operations, the drill string and bit are rotated by means of either a “rotary table” or a “top drive” associated with a drilling rig erected at the ground surface over the wellbore (or, in offshore drilling operations, on a seabed-supported drilling platform or a suitably adapted floating vessel).

15 During the drilling process, a drilling fluid (also called “drilling mud”, or simply “mud”) is pumped under pressure downward through the drill string, out the drill bit into the wellbore, and then upward back to the surface through the annular space between the drill string and the wellbore. The drilling fluid, which may be water-based or oil-based, carries wellbore cuttings to the surface, but can also perform other valuable functions, including enhancement of drill bit performance (e.g., by ejection of fluid under pressure through ports in the drill bit, creating mud jets that blast into and weaken the underlying formation in advance of the drill bit), drill bit cooling, and formation of a protective cake on the wellbore wall (to stabilize and seal the wellbore wall).

25 Particularly since the mid-1980s, it has become increasingly common and desirable in the oil and gas industry to use “directional drilling” techniques to drill horizontal and other non-vertical wellbores, to facilitate more efficient access to and

production from larger regions of subsurface hydrocarbon-bearing formations than would be possible using only vertical wellbores. In directional drilling, specialized drill string components and “bottomhole assemblies” (BHAs) are used to induce, monitor, and control deviations in the path of the drill bit, so as to produce a wellbore of desired non-
5 vertical configuration.

Directional drilling is typically carried out using a downhole motor (also called a “drilling motor” or “mud motor”) incorporated into the drill string immediately above the drill bit. A typical downhole motor assembly includes the following primary components (listed in sequence, from the top of the motor assembly):

- 10 • a top sub adapted to facilitate connection to the lower end of a drill string (“sub” being the common general term in the oil and gas industry for any small or secondary drill string component);
- a power section operably connected to the top sub;
- a drive shaft housing (which may be straight, bent, or incrementally adjustable
15 between zero degrees and a maximum angle);
- a drive shaft enclosed within the drive shaft housing, with the upper end of the drive shaft being operably connected to the power section; and
- a bearing section comprising a bearing mandrel coaxially and rotatably disposed
20 within a bearing mandrel housing, with an upper end coupled to the lower end of the drive shaft, and a lower end adapted for connection to a drill bit.

The bearing mandrel is rotated by the drive shaft, which rotates in response to the flow of drilling fluid under pressure through the power section. The bearing mandrel rotates relative to the bearing mandrel housing, which is connected to the drill string (via the drive shaft housing and other housing sections forming part of the BHA) such that the
25 bearing mandrel housing rotates with the drill string.

Conventional downhole motor assemblies commonly include power sections incorporating either a “Moineau” drive system (i.e., a progressive cavity motor,

comprising a positive displacement motor of well-known type, with a helically-vaned rotor eccentrically rotatable within a stator section) or a turbine-type drive system.

In one operational mode, a downhole motor may rotate the bit without concurrent rotation of the drill string; this is referred to as “slide drilling”. In another operational mode, the downhole motor may rotate the bit relative to the drill string in conjunction with rotation of the drill string by a top drive or rotary table.

In recent years, the available torque output of downhole motor power sections has continued to increase due to improved technologies and manufacturing capabilities, and is outpacing the torsional capacity of downhole motors. This trend appears likely to continue as increasingly higher torques are required for drilling through hard subsurface formation materials.

Such high torque requirements are straining the capabilities of conventional downhole motors, causing premature failures and unfavorable drilling conditions such as “stick slip” and “BHA whirl” (terms that will be familiar to persons skilled in the art). Due to the design characteristics of conventional drilling tools, increased reactive torque loads are being transferred through the drill string components, resulting in back-offs and fatigue failures.

For the foregoing reasons, there is a need for downhole motors that will allow the use of lower-torque conventional power sections to drill through hard subsurface materials while reducing the magnitude of reactive torque loads being transferred to the drill string.

BRIEF SUMMARY

In general terms, the present disclosure teaches embodiments of downhole motors in which intermittent rotational and/or axial impacts are applied to the bearing mandrel and, therefore, to the drill bit.

In a first embodiment of a downhole motor in accordance with this disclosure (which first embodiment will be referred to herein for convenience as an “impact driver

motor”), the bearing mandrel is rotated relative to the other primary drill string components by the application of regular axial and rotational impacts to the bearing mandrel, so as to rotate the bearing mandrel and the drill bit relative to the drill string. The impact driver motor can be used either for slide drilling operations or in conjunction
5 with rotation of the drill string.

A second embodiment of a downhole motor in accordance with this disclosure (which second embodiment will be referred to herein for convenience as a “torsional impact motor”) is particularly intended for enhancing drilling effectiveness and efficiency by a higher frequency of axial impacts being applied to the bearing mandrel to enhance
10 drilling effectiveness while continuously rotating the bit with the drive shaft assembly. In certain variants of the torsional impact motor, the impacts applied to the bearing mandrel may include a rotational (i.e., torque) component, inducing relative rotation between the bearing mandrel and the drill string.

Accordingly, the present disclosure teaches a downhole motor that includes:

- 15 • a bearing mandrel rotatably disposed within a housing;
- an impact adapter disposed above and connected to the bearing mandrel so as to be rotatable with the bearing mandrel, with the impact adapter having an upper end with upwardly-projecting impact adapter teeth;
- a drive mandrel disposed within the housing above and in coaxial alignment with
20 the impact adapter, with the drive mandrel being both rotatable and axially movable relative both to the housing and the impact adapter, and with the drive mandrel having a lower end with downwardly-projecting drive mandrel teeth that are engageable with the impact adapter teeth;
- a cam apparatus associated with the drive mandrel; and
- 25 • kinetic energy storage means associated with the drive mandrel and the cam assembly.

This downhole motor and its components are configured such that:

- rotation of the drive mandrel (such as by the power section of the downhole motor) will cause axially-upward movement of the drive mandrel relative to the impact adapter and the housing, resulting in kinetic energy being stored in the kinetic energy storage means; and
- 5
- further rotation of the drive mandrel will cause axially-downward movement of the drive mandrel so as to release the kinetic energy stored in the kinetic energy storage means, such that the drive mandrel imparts axial impact forces to the bearing mandrel.

10 In alternative variants, the downhole motor may be configured such that both rotational and axial impact forces will be imparted to the bearing mandrel upon the release of kinetic energy stored in the kinetic energy storage means.

15 In one non-limiting variant of the downhole motor, the cam apparatus includes a cam ring that has a central opening, and the cam ring is mounted within the bore of the housing so as to be rotatable with the housing. The drive mandrel passes through the central opening in the cam ring such that the drive mandrel is axially movable relative to the cam ring and the cam ring is rotatable about the drive mandrel. A plurality of cam lobes are formed on an upper end of the cam ring, with uniform angular intervals between adjacent cam lobes. Each cam lobe has a cam profile that defines a lower flat section, which is contiguous with a ramp section, which is contiguous with an upper flat section, 20 which is contiguous with an axial face, which is contiguous with the lower flat section of the next adjacent cam lobe.

25 The cam apparatus in this variant also includes a roller cage disposed above the cam ring and coaxial therewith. The roller cage is disposed around and fixed to drive mandrel such that the roller cage is rotatable with the drive mandrel. The roller cage includes a plurality of rollers corresponding to the cam lobes in terms of number and angular spacing, with the rollers being configured for rollable engagement with the cam profiles of the cam lobes.

The kinetic energy storage means may comprises a helical spring disposed within an annulus between the drive mandrel and the housing, with a lower end of the spring

reacts against the roller cage and an upper end of the spring reacting against a shoulder formed in the bore of the housing. In alternative variants, the kinetic energy storage means may be provided in the form of a gas spring.

5 In some variants of the downhole motor, the impact adapter teeth and the drive mandrel teeth are completely disengaged when the drive mandrel is at its uppermost axial position. In other variants, the impact adapter teeth and the drive mandrel teeth are never completely disengaged.

BRIEF DESCRIPTION OF THE DRAWINGS

10 Embodiments in accordance with the present disclosure will now be described with reference to the accompanying Figures, in which numerical references denote like parts, and in which:

15 **FIGURE 1** is an isometric view of the impact mechanism of a first embodiment of a downhole motor assembly in accordance with the present disclosure, shown with portions of the motor assembly housing removed for illustration purposes.

FIGURE 2A is an enlarged isometric detail of the impact mechanism shown in FIG. 1, illustrating the anvil adapter and the hammer mandrel of the impact mechanism in a first operational position.

20 **FIGURE 2B** is an enlarged isometric detail of the impact mechanism shown in FIG. 1, illustrating the anvil adapter and the hammer mandrel of the impact mechanism in a second operational position.

FIGURE 3 is a longitudinal cross-section through the impact mechanism shown in FIGS. 1, 2A, and 2B.

25 **FIGURE 4** is an isometric view of the impact mechanism of a second embodiment of a downhole motor assembly in accordance with the present disclosure, shown with portions of the motor assembly housing removed for illustration purposes.

FIGURE 5A is an enlarged isometric detail of the impact mechanism shown in FIG. 4, illustrating the impact adapter and the drive mandrel of the impact mechanism in a first operational position.

5 **FIGURE 5B** is an enlarged isometric detail of the impact mechanism shown in FIG. 1, illustrating the impact adapter and the drive mandrel of the impact mechanism in a second operational position.

FIGURE 6 is a longitudinal cross-section through the impact mechanism shown in FIGS. 4, 5A, and 5B.

10

DETAILED DESCRIPTION

Impact Driver Motor

FIGS. 1, 2A, 2B, and 3 illustrate an exemplary variant of an impact driver motor **100** in accordance with the present disclosure.

15 Referring first to FIGS. 1 and 3, impact driver motor **100** includes a bearing mandrel **20** (having a lower end **10L** adapted for connection to a drill bit), with an upper portion of bearing mandrel **20** being rotatably disposed within a bearing mandrel housing **30** (which forms part of the overall motor assembly housing, and only part of which is shown in FIG. 1). An upper end **10U** of the assembly shown in FIG. 1 is adapted for connection to a downhole motor drive shaft (and an associated drive shaft housing). As
20 shown in FIG. 3, bearing mandrel **20** has a central bore **15** through which drilling fluid can be pumped to the drill bit. Central bore **15** is in fluid communication with the drill string through contiguous bores or passages in other components of the motor assembly between bearing mandrel **20** and the drill string.

25 In the illustrated variant, a balancing piston **40** is disposed within an annulus **25** between bearing mandrel **20** and bearing mandrel housing **30** for prevention of differential pressure across a rotating seal between bearing mandrel **20** and bearing mandrel housing **30**. However, this is by way of illustration only; the above-described

function of piston **40** could be accomplished by other means known to persons skilled in the art, and piston **40** or functionally-equivalent means are not essential elements of the broadest embodiments within the scope of this disclosure.

As best appreciated with reference to FIG. 3, the upper end of bearing mandrel **20** is connected to the lower end of an impact adapter so as to be rotatable therewith. For purposes of describing the impact driver motor illustrated in FIGS. 1, 2A, 2B, and 3, this impact adapter will be referred to as anvil adapter **110**, to distinguish it from the impact adapter of the torsional impact motor described further on in this disclosure and illustrated in FIGS. 4 5A, 5B, and 6.

Anvil adapter **110** is rotatable within an anvil adapter housing **115** (which forms part of the overall motor assembly housing, and is shown only in FIG. 3) which is connected to bearing mandrel housing **30** so as to be rotatable therewith. A plurality of anvil adapter teeth **112** project axially upward from the upper end of anvil adapter **110** at equal angular intervals around the perimeter of anvil adapter **110**. In the illustrated variant, anvil adapter **110** has two anvil adapter teeth **112** at 180° spacing; however, the number of anvil adapter teeth **112** could be higher in alternative variants without departing from the scope of the present disclosure.

Although the two anvil adapter teeth in the illustrated variant are of essentially identical configuration, they are denoted in FIGS. 2A and 2B by reference numbers **112A** and **112B** for illustrative purposes. Annular shoulders **116** (or **116A** and **116B** in the illustrated embodiment, per FIGS. 2A and 2B) are formed between adjacent anvil adapter teeth (**112A**, **112B**). Optionally, notches **114** may be provided at junctures of anvil adapter teeth **112** and shoulders **116**, as shown by way of example in FIGS. 2A and 2B, to provide a lubricant flow path.

A drive mandrel is provided above and in coaxial alignment with anvil adapter **110**. For purposes of describing the impact driver motor illustrated in FIGS. 1, 2A, 2B, and 3, this drive mandrel will be referred to as hammer mandrel **110**, to distinguish it from the drive mandrel of the torsional impact motor described further on in this disclosure and illustrated in FIGS. 4 5A, 5B, and 6.

Hammer mandrel **120** is rotatable within a hammer mandrel housing **125** (which forms part of the overall motor assembly housing, and is shown only in FIG. 3), which is connected to anvil adapter housing **115** so as to be rotatable therewith. A plurality of hammer mandrel teeth **122** (corresponding to anvil adapter teeth **112** in number and angular spacing) project axially downward from the lower end of hammer mandrel **120**.

Although the two hammer mandrel teeth in the illustrated variant are of essentially identical configuration, they are denoted in FIGS. 2A and 2B by reference numbers **122A** and **122B** for illustrative purposes. Annular shoulders **126** (or **126A** and **126B** in the illustrated embodiment, per FIGS. 2A and 2B) are formed between adjacent hammer mandrel teeth (**122A**, **122B**). Optionally, notches **124** may be provided at junctures of hammer mandrel teeth **122** and shoulders **126**, as shown by way of example in FIGS. 2A and 2B, to provide a lubricant flow path. Hammer mandrel **120** is axially movable within hammer mandrel housing **125** such that it can stroke axially relative to anvil adapter **110**.

An upper cylindrical portion of hammer mandrel **120** passes through and is axially movable relative to a cam ring **130**, which is mounted within the bore of the motor assembly housing so as to be rotatable therewith; hammer mandrel **120** therefore is rotatable relative to cam ring **130**. The upper end of cam ring **130** is formed with a plurality of cam lobes **131** (corresponding to teeth **112** and **122** in number and angular spacing). In the illustrated variant, cam ring **130** has two cam lobes, which although of essentially identical configuration are denoted in FIGS. 2A and 2B by reference numbers **131A** and **131B** for illustrative purposes. Each cam lobe (**131A**, **131B**) in the illustrated variant has a cam profile defining a lower flat section (**132A**, **132B**), which is contiguous with a ramp section (**134A**, **134B**), which is contiguous with an upper flat section (**136A**, **136B**), which is contiguous with an axial face (**138A**, **138B**), which is contiguous with the lower flat section (**132B** or **132A**) of the other cam lobe (**131B** or **131A**).

Above cam ring **130**, a roller cage **140** is coaxially disposed around and fixed to hammer mandrel **120** so as to be rotatable therewith. Roller cage **140** includes a plurality of rollers **142** corresponding to cam lobes **131** in number and angular spacing, and

configured for rollable engagement with the cam profiles of cam lobes **131**. In the illustrated variant, roller cage **140** has two rollers, which although of essentially identical configuration are denoted in FIGS. 2A and 2B by reference numbers **142A** and **142B** for illustrative purposes.

5 Above roller cage **140**, hammer mandrel **120** passes through a helical spring **150** disposed within an annulus **121** between hammer mandrel **120** and hammer mandrel housing **125**. As best seen in FIG. 3, spring **150** bears at its lower end against roller cage **140** and at its upper end against a shoulder formed in the bore of hammer mandrel housing **125**. Annulus **121** will preferably be filled with a suitable oil.

10 As best seen in FIG. 3, the upper end of hammer mandrel housing **125** connects to a piston housing **160**, and the upper end of hammer mandrel **120** extends into piston housing **160** and then is operably connected to the power section (not shown) of the downhole motor assembly. In the illustrated variant, an annulus **161** between hammer mandrel **120** and piston housing **160** is also filled with a suitable oil, and a balancing piston **165** is disposed in annulus **161** to provide hydraulic pressure balancing during
15 operation of impact driver motor **100**.

 The operation of impact driver motor **100** can be best understood with reference to FIGS. 2A and 2B. The rotation of hammer mandrel **120** (by the power section of the downhole motor) causes rollers **142A** and **142B** to travel along the cam profiles of cam
20 ring **130**. Because cam ring **130** is fixed relative to the housing assembly, roller cage **140** and hammer mandrel **120** are drawn upward within hammer mandrel housing **125** as the rollers (**142A**, **142B**) move up the cam ramp sections (**134A**, **134B**) onto the upper flat sections (**136A**, **136B**) of the cam profile as shown in FIG. 2A, completely disengaging hammer mandrel **120** from anvil adapter **110**, and axially compressing helical spring **150**,
25 resulting in kinetic energy being stored therein. At this point, hammer mandrel **120** does not transfer any torque to the bit (via anvil adapter **110**), as the bit is not rotating at this point. The additional power section pressure required to turn the rollers **142** up the cam ramp sections **134** can now be fully released, as no drilling loads are acting on the power section.

As rotation of hammer mandrel **120** continues, and as seen in FIG. 2B, the rollers (**142A**, **142B**) drop off the upper flat sections that they had been on (i.e., **136A**, **136B**, as seen in FIG. 2A), and onto the adjacent lower flat sections (**132B**, **132A**). This causes instantaneous release of the stored energy in spring **150** such that hammer mandrel **120** strokes downward and imparts an axial impact force against anvil adapter **110** (by way of either axial impact of hammer mandrel teeth **122A**, **122B** against annular shoulders **116A**, **116B** on anvil adapter **110**, or axial impact of annular shoulders **126A**, **126B** on hammer mandrel **120** against anvil adapter teeth **112A**, **112B**), which in turn transfers the axial impact force to the drill bit via bearing mandrel **20**. The axial impact force from the stored energy in spring **150** is augmented by additional stored energy in the mass of the drive shaft and the power section rotor above hammer mandrel **120**, which additional energy is released concurrently with the energy in spring **150**.

Due to the continuing rotation of hammer mandrel **120**, the side faces of the hammer mandrel teeth (**122A**, **122B**) also impart lateral impact forces against the side faces of the next-adjacent anvil adapter teeth (i.e., **112B** and **112A**) as seen in FIG. 2B, thus incrementally rotating anvil mandrel **110**, bearing mandrel **20**, and the drill bit relative to the drill string.

As rotation of the drive shaft (not shown) continues, the rollers (**142A**, **142B**) again move up the cam ramp sections **132**, as shown in FIG. 2B, raising hammer mandrel **120** so as to fully disengage the hammer mandrel teeth (**122A**, **122B**) from anvil adapter **110** and again compressing spring **150**, with the axial loads on the rotor, the drive shaft, and hammer mandrel **120** being reacted through cam ring **130** to the motor assembly housing.

This application of regular impact forces to anvil adapter **110** occurs continuously as the drive shaft and hammer mandrel **120** rotate, with the number of impacts per rotation equalling the number of anvil adapter teeth **112** (and hammer mandrel teeth **122** and cam lobes **131**). For each full rotation of the rotor, the bit will only rotate a percentage of a turn, and this will lessen the reactive torque transferred to the drill string.

Torsional Impact Motor

FIGS. 4, 5A, 5B, and 6 illustrate an exemplary variant of a “torsional impact motor” in accordance with the present disclosure.

Referring first to FIGS. 4 and 6, torsional impact motor **200** includes a bearing mandrel **20** having a lower end (not shown) adapted for connection to a drill bit, with an upper portion of bearing mandrel **20** being rotatably disposed within a bearing mandrel housing **30** (only part of which is shown in FIG. 4). An upper end **10U** of the assembly shown in FIG. 4 is adapted for connection to a downhole motor drive shaft (and drive shaft housing). As shown in FIG. 6, bearing mandrel **20** has a central bore **15** through which drilling fluid can be pumped to the drill bit. Central bore **15** is in fluid communication with the drill string through contiguous bores or passages in other components of the motor assembly between bearing mandrel **20** and the drill string. In the illustrated variant, a balancing piston **40** is disposed within an annulus **25** between bearing mandrel **20** and bearing mandrel housing **30**.

As best appreciated with reference to FIG. 6, the upper end of bearing mandrel **20** is connected to the lower end of an impact adapter **210** so as to be rotatable therewith. Impact adapter **210** is rotatable within an impact adapter housing **215** (shown only in FIG. 6) which is connected to bearing mandrel housing **30** so as to be rotatable therewith. A plurality of impact adapter teeth **212** project axially upward from the upper end of impact adapter **210** at equal angular intervals around the perimeter of impact adapter **210**. In the illustrated variant, impact adapter **210** has four impact adapter teeth **212** at 90° spacing; however, the number of impact adapter teeth **212** could be higher or lower in alternative variants without departing from the scope of the present disclosure. Although the four impact adapter teeth in the illustrated variant are of essentially identical configuration, they are denoted in FIGS. 5A and 5B by reference numbers **212A** and **212B** for illustrative purposes.

A drive mandrel **220** is provided above and in coaxial alignment with impact adapter **210**. Drive mandrel **220** is rotatable within a drive mandrel housing **225** (shown only in FIG. 6), which is connected to impact adapter housing **215** so as to be rotatable

therewith. A plurality of drive mandrel teeth **222** (corresponding to impact adapter teeth **212** in number and angular spacing) project axially downward from the lower end of drive mandrel **220**.

5 As seen in greater detail in FIG. 5A, each impact adapter tooth **212** in the illustrated variant has an upper end face **213** extending between an axial side face **214** and an angled side face **216**, creating an annular shoulder **218** on the upper end of impact adapter **210** between the roots of each pair of adjacent teeth **212**. Each drive mandrel tooth **222** has a lower end face **225** extending between an axial side face **224** and an angled side face **226**, creating an annular shoulder **228** on the lower end of drive mandrel
10 **220** between the roots of each pair of adjacent teeth **222**.

As seen in FIGS. 5A and 5B, drive mandrel **220** is assembled in engagement with impact adapter **210** such that the lower end face **225** of each drive mandrel tooth **222** faces the upper end face **213** of a corresponding impact adapter tooth **212**, with the axial side face **224** of each drive mandrel tooth **222** being adjacent to and parallel to the axial
15 side face **214** of the corresponding impact adapter tooth **212**, and with the angled side face **226** of each drive mandrel tooth **222** being adjacent to and parallel to the angled side face **216** of the corresponding impact adapter tooth **212**.

Drive mandrel **220** is axially movable within drive mandrel housing **225** such that it can stroke axially relative to impact adapter **210**. However, the assembly is configured
20 such that drive mandrel **220** is never completely disengaged from impact adapter **210**, and relative rotational movement between drive mandrel **220** and impact adapter **210** is limited to the angular twist between impact adapter teeth **212** and drive mandrel teeth **222**.

An upper cylindrical portion of drive mandrel **220** passes through and is axially
25 movable relative to a cam ring **230** which is mounted within the bore of the motor assembly housing so as to be rotatable therewith; drive mandrel **220** therefore is rotatable relative to cam ring **230**. The upper end of cam ring **230** is formed with a plurality of cam lobes **231**. In the illustrated variant, cam ring **230** has two cam lobes, which although of essentially identical configuration are denoted in FIGS. 5A and 5B by

reference numbers **231A** and **231B** for illustrative purposes. Each cam lobe (**231A**, **231B**) in the illustrated variant has a cam profile defining a lower flat section (**232A**, **232B**), which is contiguous with a ramp section (**234A**, **234B**), which is contiguous with an upper flat section (**236A**, **236B**), which is contiguous with an axial face (**238A**, **238B**),
5 which is contiguous with the lower flat section (**232B** or **232A**) of the other cam lobe (**231B** or **231A**).

Above cam ring **230**, a roller cage **240** is coaxially disposed around and fixed to drive mandrel **220** so as to be rotatable therewith. Roller cage **240** includes a plurality of rollers **242** corresponding to cam lobes **231** in number and angular spacing, and
10 configured for rollable engagement with the cam profiles of cam lobes **231**. In the illustrated variant, roller cage **240** has two rollers, which although of essentially identical configuration are denoted in FIGS. 5A and 5B by reference numbers **242A** and **242B** for illustrative purposes.

Above roller cage **240**, drive mandrel **220** passes through a helical spring **250**
15 disposed within an annulus **221** between drive mandrel **220** and drive mandrel housing **225**. As best seen in FIG. 6, spring **250** bears at its lower end against roller cage **240** and at its upper end against a shoulder formed in the bore of drive mandrel housing **225**. Annulus **221** will preferably be filled with a suitable oil.

As best seen in FIG. 6, the upper end of drive mandrel housing **225** connects to a
20 piston housing **260**, and the upper end of drive mandrel **220** extends into piston housing **260** and then is operably connected to the power section (not shown) of the downhole motor assembly. In a preferred variant, an annulus **261** between drive mandrel **220** and piston housing **260** is also filled with a suitable oil (not necessarily of the same type as the oil in annulus **221**), and a pressure equalization piston **265** is disposed in annulus **261**
25 to provide hydraulic pressure balancing during operation of torsional impact motor **200**.

The operation of torsional impact motor **200** can be best understood with reference to FIGS. 5A and 5B. The rotation of drive mandrel **220** (by the power section of the downhole motor) causes rollers **242A** and **242B** to travel along the cam profiles of cam ring **230**. Because cam ring **230** is fixed to drive mandrel housing **225**, roller cage

240 and drive mandrel **220** are drawn upward within drive mandrel housing **225** as the rollers (**242A**, **242B**) move up the cam ramp sections (**234A**, **234B**) onto the upper flat sections (**236A**, **236B**) of the cam profile as shown in FIG. 5A, and this in turn causes compression of helical spring **250**, resulting in kinetic energy being stored therein.

5 As rotation of drive mandrel **220** continues, and as seen in FIG. 2B, the rollers (**242A**, **242B**) drop off the upper flat sections that they had been on (i.e., **236A**, **236B**, as seen in FIG. 5A), and onto the adjacent lower flat sections (**232B**, **232A**). This causes instantaneous release of the stored energy in spring **250** such that drive mandrel **220** strokes downward and imparts an axial impact force against impact adapter **210** (by way
10 of either axial impact of lower end faces **223** of drive mandrel teeth **222** against annular shoulders **218** on impact adapter **210**, or axial impact of annular shoulders **228** on drive mandrel **220** against upper end faces **213** on impact adapter teeth **212**), which in turn transfers the axial impact force to the drill bit via bearing mandrel **20**. The axial impact force from the stored energy in spring **250** is augmented by additional stored energy in
15 the mass of the drive shaft and rotor above drive mandrel **220**, which additional energy is released concurrently with the energy in spring **250**.

At the same time, the angled side faces **226** of the drive mandrel teeth **222** impart lateral impact forces against the angled side faces **216** of the corresponding impact adapter teeth **212** as seen in FIG. 5A, thus incrementally rotating impact adapter **210**,
20 bearing mandrel **20**, and the drill bit relative to the drill string. The magnitude of these lateral impact forces will be a function of the angle of angled side faces **216** and **226** (which is shown by way of non-limiting example in FIGS. 5A and 5B as approximately 15°).

This application of intermittent impact forces to impact adapter **210** occurs
25 continuously as the power section and drive mandrel **220** rotate, with the number of impacts per rotation equalling the number of cam lobes **231**.

Unlike the operation of impact driver motor **100**, where the bit turns only when hammer mandrel **120** is engaged with anvil adapter **110**, the operation of torsional impact motor **200** is characterized by constant rotation of the bit, but with the effectiveness of the

bit being augmented by the application of axial and torsional impacts to increase the rate of penetration (ROP).

The imparting of axial and torsional impacts and the provision within the motor assembly of an oscillating internal mass (comprising, in the case of impact driver motor **100**, hammer mandrel **120**, the drive shaft, and the rotor; or, in the case of torsional impact motor **200**, drive mandrel **220**, the drive shaft, and the rotor) have an operational effect analogous to placing a vibration-inducing tool (or an additional vibrating-inducing tool) in the BHA very close to the bit.

It is to be understood that the scope of the claims appended hereto should not be limited by the preferred embodiments described and illustrated herein, but should be given the broadest interpretation consistent with the description as a whole. It is also to be understood that the substitution of a variant of a claimed element or feature, without any substantial resultant change in functionality, will not constitute a departure from the scope of the disclosure. By way of only one non-limiting example, variant embodiments within the scope of the present disclosure could incorporate alternative known means for storing kinetic energy in substitution for helical spring **150** (or **250**), such as, for example, a gas spring, with annulus **121** (or **221**) being made substantially gas-tight and filled with a compressible gas.

In this patent document, any form of the word "comprise" is to be understood in its non-limiting sense to mean that any element following such word is included, but elements not specifically mentioned are not excluded. A reference to an element by the indefinite article "a" does not exclude the possibility that more than one of the element is present, unless the context clearly requires that there be one and only one such element.

Any use of any form of the terms "connect", "engage", "couple", "attach", or any other term describing an interaction between elements is not meant to limit the interaction to direct interaction between the subject elements, and may also include indirect interaction between the elements such as through secondary or intermediary structure. Relational or relative terms (including but not limited to "horizontal", "vertical", "parallel", and "perpendicular") are not intended to denote or require absolute

mathematical or geometrical precision. Accordingly, such terms are to be understood as denoting or requiring substantial precision only (e.g., “substantially horizontal”) unless the context clearly requires otherwise.

5 In this patent document, certain components of disclosed embodiments are described using adjectives such as “upper” and “lower”. These adjectives are used to establish a convenient frame of reference to facilitate explanation and to enhance the reader’s understanding of spatial relationships and relative locations of the various elements and features of the components in question. The use of these adjectives is not to be interpreted as implying that they will be strictly applicable in all practical applications and usages of downhole motor assemblies in accordance with the present disclosure, or 10 that such motor assemblies must be used in spatial orientations that are consistent with the strict meanings of these adjectives. For example, motor assemblies in accordance with the present disclosure may be used in drilling horizontal or angularly-oriented wellbores. For greater certainty, therefore, the adjectives “upper” and “lower”, when used herein with reference to disclosed motor assemblies and components thereof, should 15 be understood in the sense of “toward the upper or lower end (as the case may be) of the drill string”, regardless of what the actual spatial orientation of the motor assembly and the drill string might be in a given practical usage.

Wherever used in this document, the terms “typical” and “typically” are to be 20 interpreted in the sense of representative or common usage or practice, and are not to be understood as implying invariability or essentiality.

25

WHAT IS CLAIMED IS:

1. A downhole motor comprising:

- (a) a bearing mandrel rotatably disposed within a housing;
- (b) an impact adapter disposed above and connected to the bearing mandrel so as to be rotatable therewith, said impact adapter having an upper end with upwardly-projecting impact adapter teeth;
- (c) a drive mandrel disposed within the housing above and in coaxial alignment with the impact adapter, said drive mandrel being rotatable and axially movable relative to the housing and relative to the impact adapter, and said drive mandrel having a lower end with downward-projecting drive mandrel teeth engageable with the impact adapter teeth;
- (d) a cam apparatus associated with the drive mandrel; and
- (e) kinetic energy storage means, said kinetic energy storage means being associated with the drive mandrel and the cam assembly;

wherein:

- (f) rotation of the drive mandrel will cause axially-upward movement of the drive mandrel relative to the impact adapter and the housing, resulting in kinetic energy being stored in the kinetic energy storage means; and
- (g) further rotation of the drive mandrel will cause axially-downward movement of the drive mandrel so as to release the kinetic energy stored in the kinetic energy storage means, such that the drive mandrel imparts axial impact forces to the bearing mandrel.

2. A downhole motor as in Claim 1 wherein rotational impact forces will be imparted to the bearing mandrel upon the release of kinetic energy stored in the kinetic energy storage means.

3. A downhole motor as in Claim 1 or Claim 2 wherein the cam apparatus comprises:

(a) a cam ring having a central opening and being mounted within the bore of the housing so as to be rotatable therewith, wherein:

5 - the drive mandrel passes through said central opening in the cam ring such that the drive mandrel is axially movable relative to the cam ring and the cam ring is rotatable about the drive mandrel;

- an upper end of the cam ring is formed with a plurality of cam lobes, with uniform angular spacing between adjacent cam lobes; and

10 - each cam lobe has a cam profile defining a lower flat section, which is contiguous with a ramp section, which is contiguous with an upper flat section, which is contiguous with an axial face, which is contiguous with the lower flat section of the next adjacent cam lobe; and

15 (b) a roller cage disposed above the cam ring and coaxial therewith, and also disposed around and fixed to drive mandrel so as to be rotatable therewith, wherein:

- the roller cage includes a plurality of rollers corresponding to cam lobes in number and angular spacing, and configured for rollable engagement with the cam profiles of the cam lobes.

20 4. A downhole motor as in any one of Claims 1-3 wherein the kinetic energy storage means comprises a helical spring disposed within an annulus between the drive mandrel and the housing.

5. A downhole motor as in Claim 3 wherein the kinetic energy storage means comprises a helical spring disposed within an annulus between the drive mandrel and the housing, wherein a lower end of the spring reacts against the roller cage and an upper end
25 of the spring reacts against a shoulder formed in the bore of the housing.

6. A downhole motor as in any one of Claims 1-3 wherein the kinetic energy storage means is provided in the form of a gas spring.

7. A downhole motor as in any one of Claims 1-6 wherein:
- 5 (a) each impact adapter tooth has an upper end face extending between an axial side face and an angled side face so as to create an annular shoulder on the upper end of the impact adapter between the roots of each pair of adjacent impact adapter teeth; and
- (b) each drive mandrel tooth has a lower end face extending between an axial side face and an angled side face so as to create an annular shoulder on the lower end of drive mandrel between the roots of each pair of adjacent teeth.
- 10 8. A downhole motor as in Claim 7 wherein each drive mandrel tooth faces the upper end face of a corresponding impact adapter tooth, with the axial side face of each drive mandrel tooth being adjacent to and parallel to the axial side face of the corresponding impact adapter tooth, and with the angled side face of each drive mandrel tooth being adjacent to and parallel to the angled side face of the corresponding impact
- 15 adapter tooth.
9. A downhole motor as in any one of Claims 1-8 wherein the impact adapter teeth and the drive mandrel teeth are completely disengaged when the drive mandrel is at its uppermost axial position.

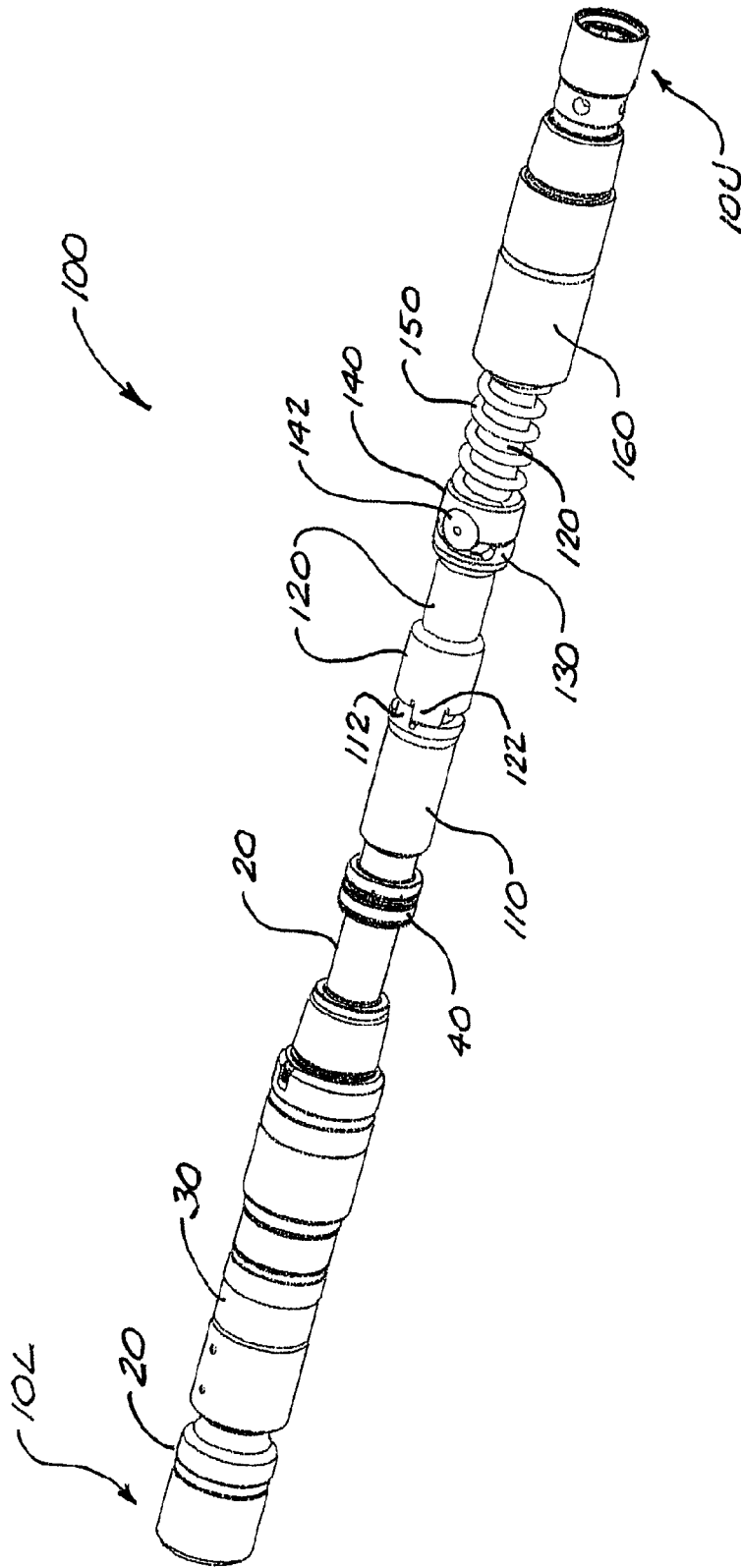

FIG. 1

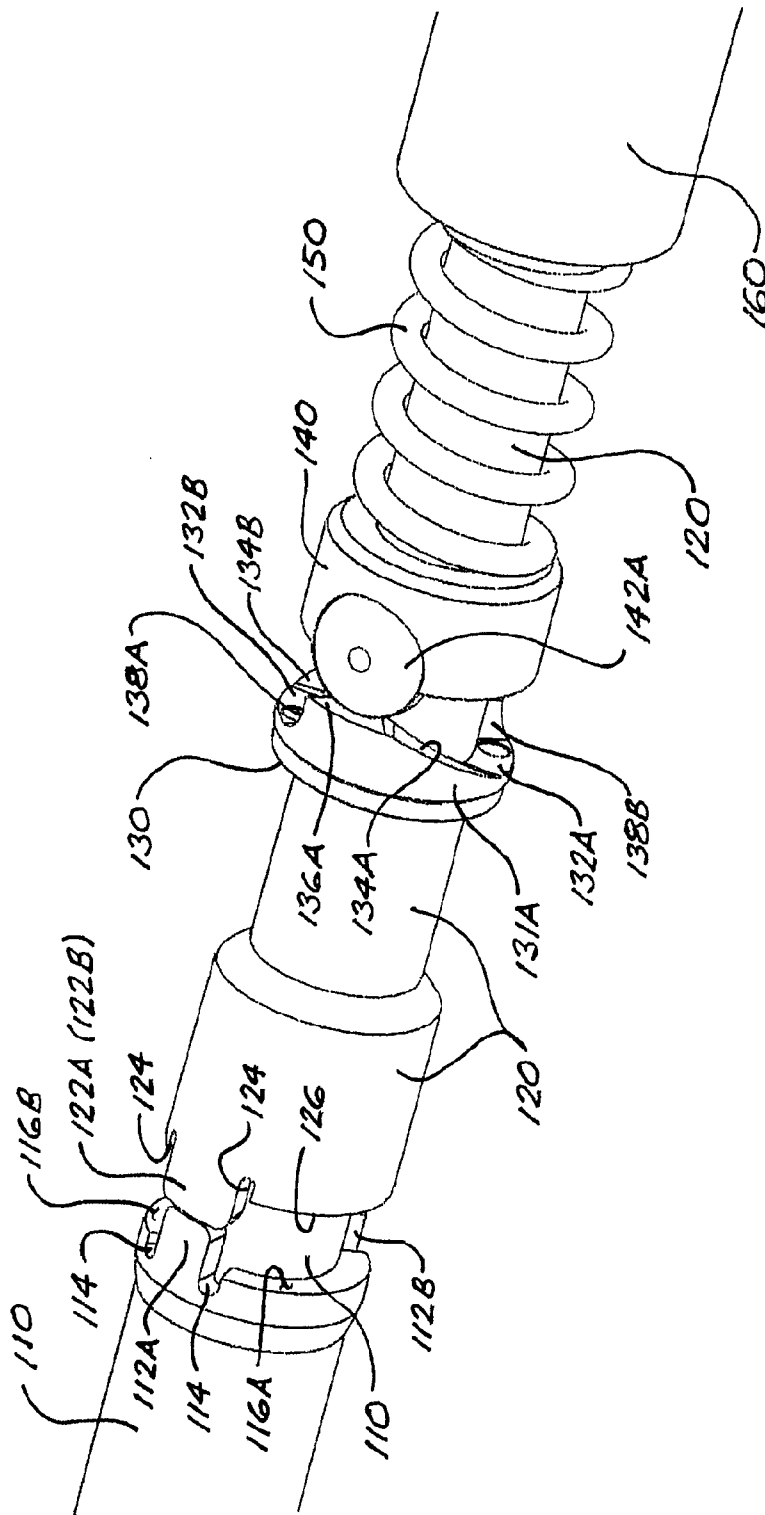

FIG. 2A

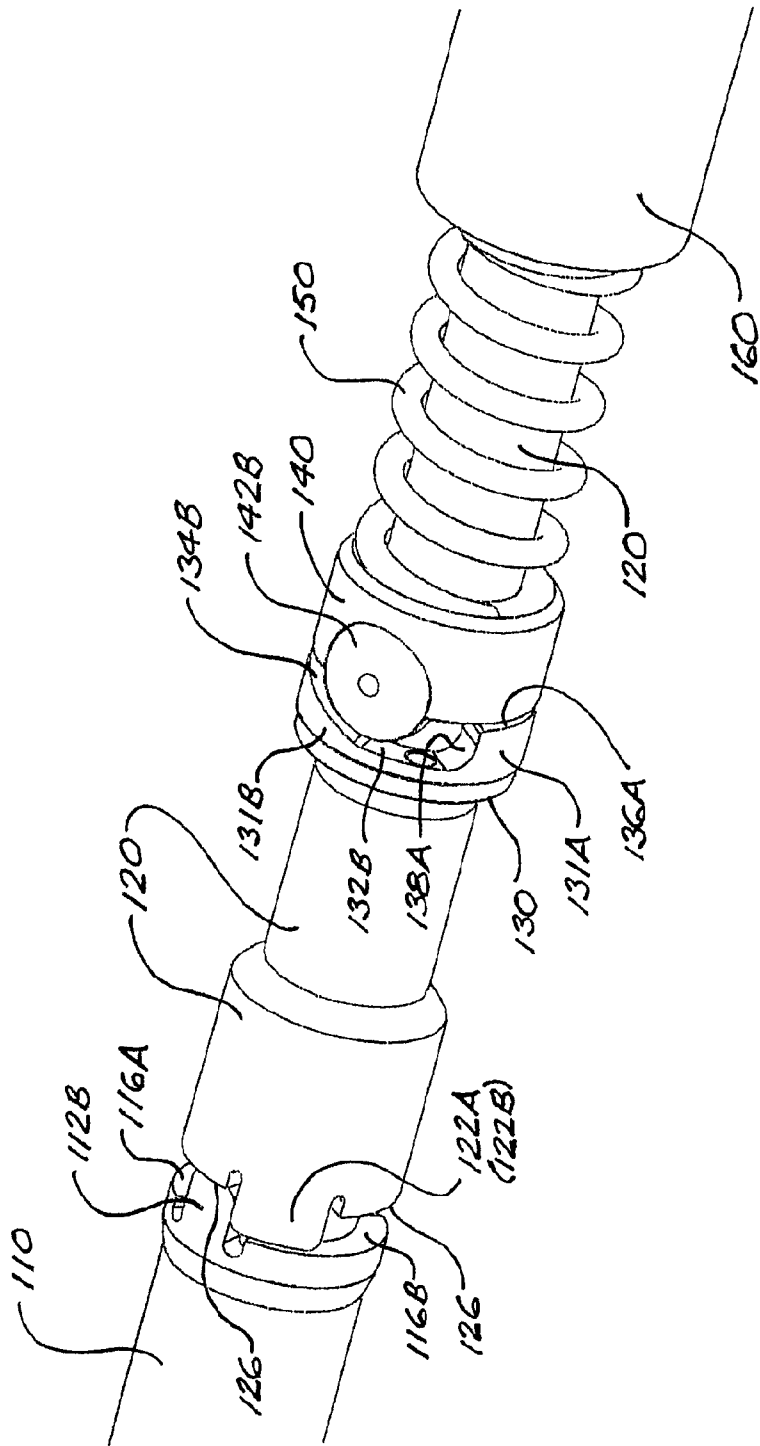

FIG. 2B

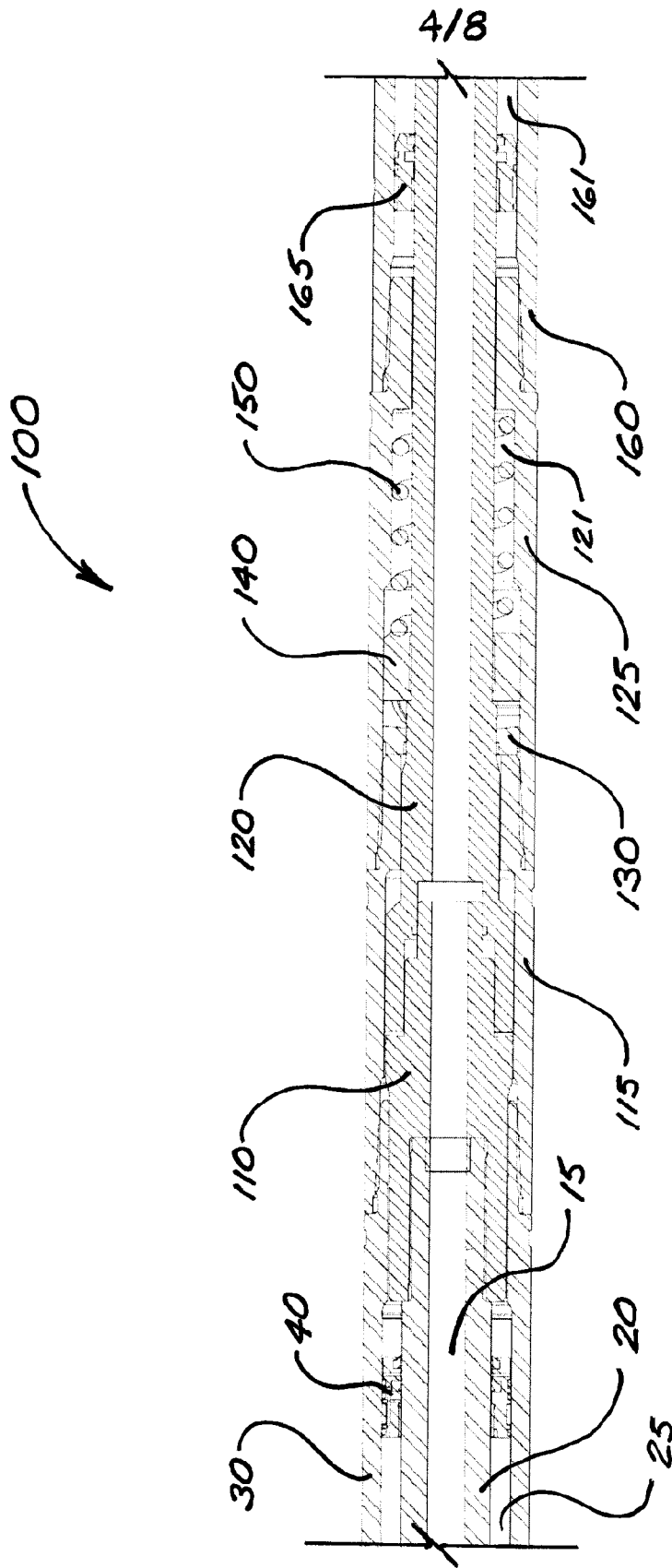

FIG. 3

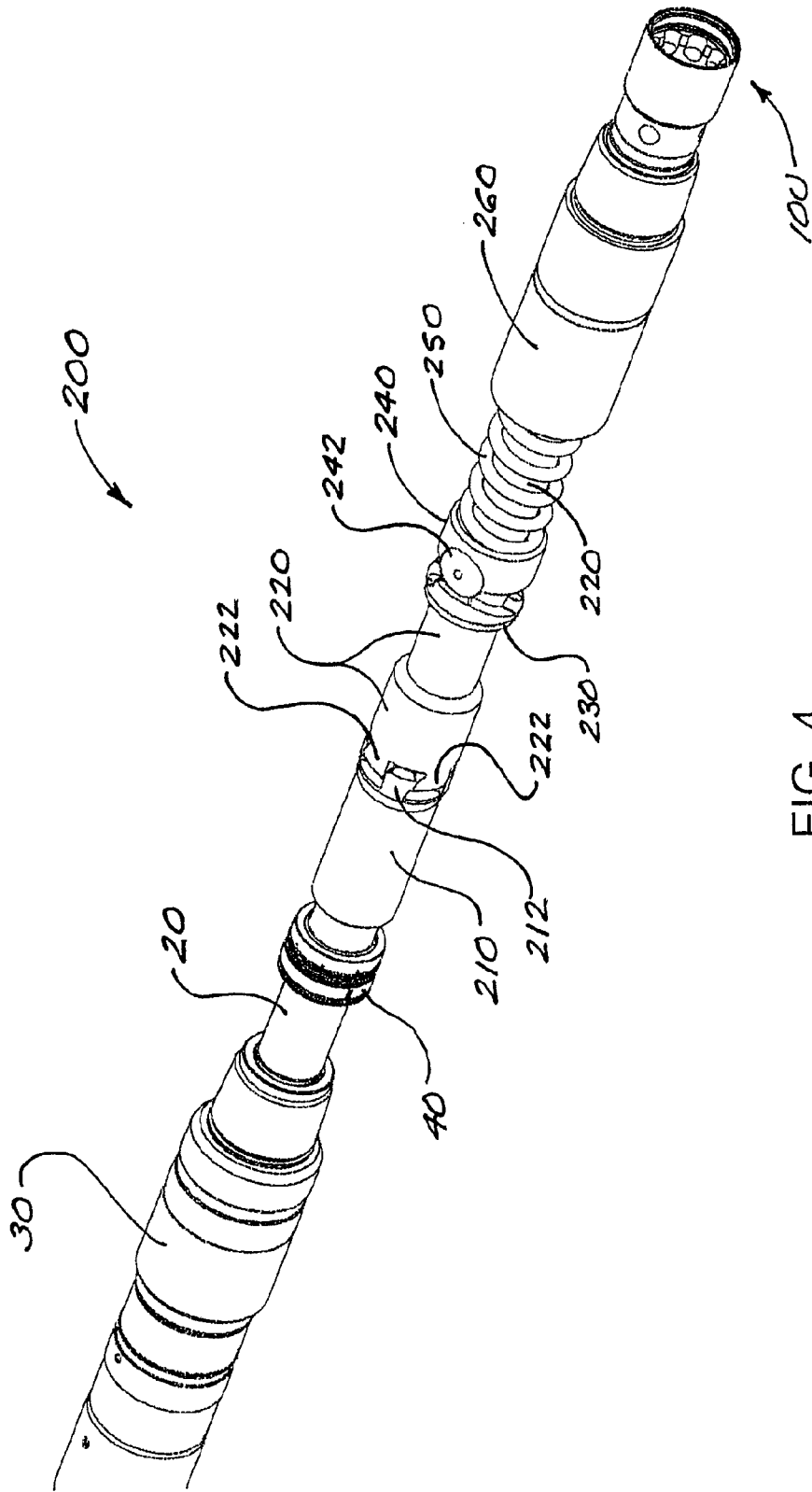

FIG. 4

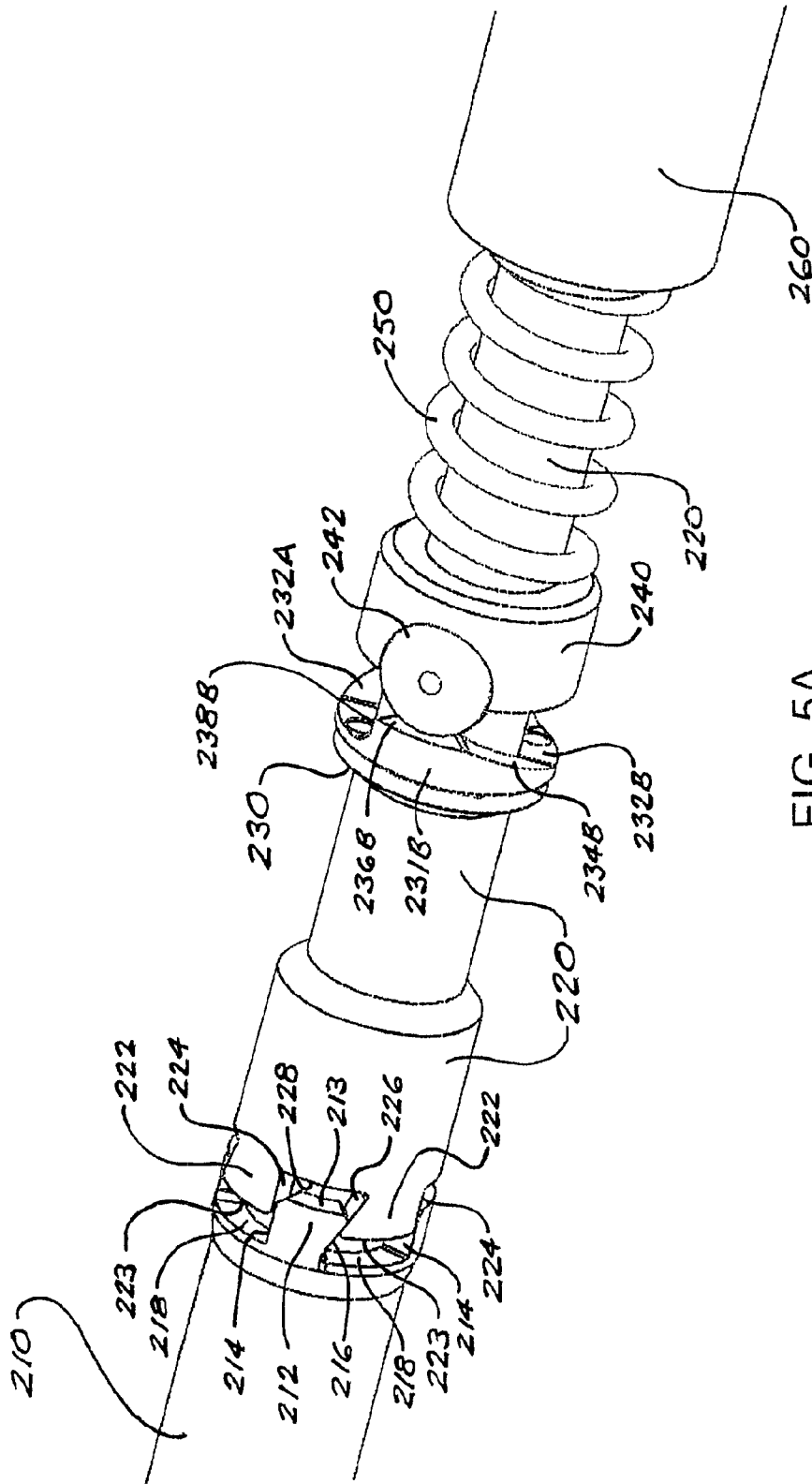

FIG. 5A

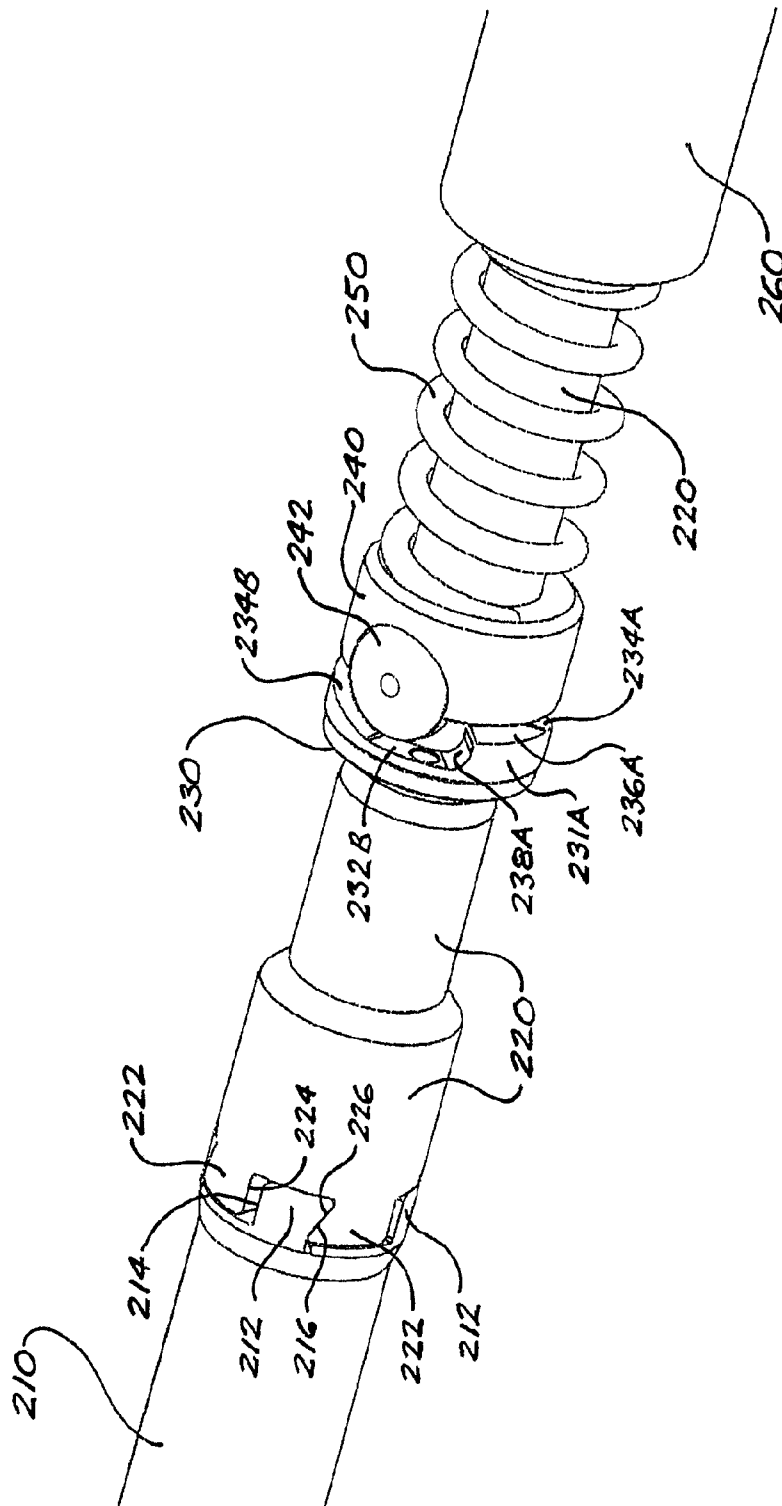

FIG. 5B

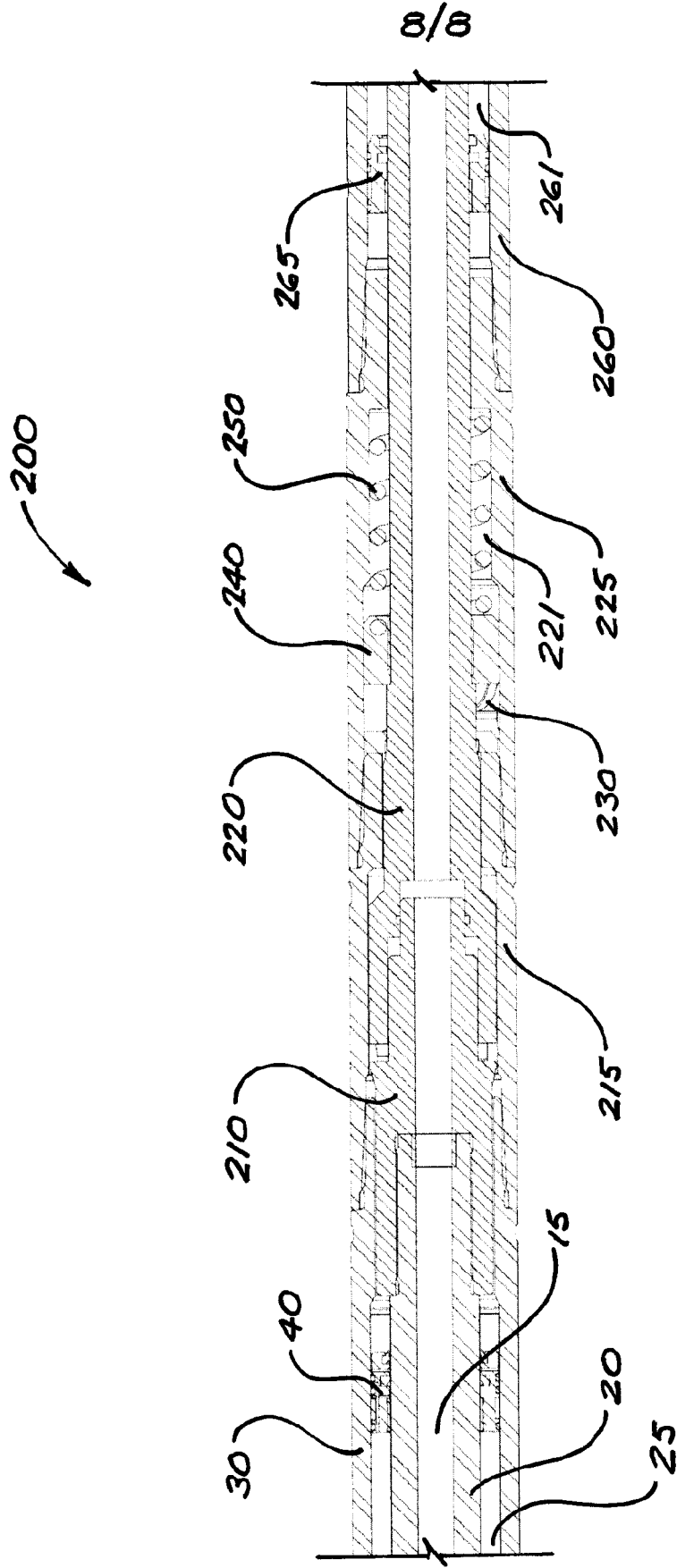

FIG. 6

INTERNATIONAL SEARCH REPORT

International application No.

PCT/CA2016/000082

A. CLASSIFICATION OF SUBJECT MATTER
 IPC: **E21B 6/02** (2006.01), **E21B 4/10** (2006.01)

According to International Patent Classification (IPC) or to both national classification and IPC

B. FIELDS SEARCHED

Minimum documentation searched (classification system followed by classification symbols)

IPC (2006.01) : E21B 6/02, E21B 4/10

Documentation searched other than minimum documentation to the extent that such documents are included in the fields searched

Electronic database(s) consulted during the international search (name of database(s) and, where practicable, search terms used)

DATABASES : Questel Orbit (FAMPAT), Canadian Patent Database (CPD)
KEYWORDS : teeth, cam, sor+, releas+, energy

C. DOCUMENTS CONSIDERED TO BE RELEVANT

Category*	Citation of document, with indication, where appropriate, of the relevant passages	Relevant to claim No.
	US 2,495,364 (CLAPP) 24 January 1950 (24-01-1950) * see whole document US 2,742,264 (SNYDER) 17 April 1956 (17-04-1956) * see whole document US 7,237,625 B2 (MINSHULL et al.) 3 July 2007 (03-07-2007) * see whole document US 4,359,109 (TRUONG-CAO) 16 November 1982 (16-11-1982) * see whole document US 4,408,570 (SCHOEFFLER) 11 October 1983 (11-10-1983) * see whole document	

Further documents are listed in the continuation of Box C.

See patent family annex.

* Special categories of cited documents:	“T” later document published after the international filing date or priority date and not in conflict with the application but cited to understand the principle or theory underlying the invention
“A” document defining the general state of the art which is not considered to be of particular relevance	“X” document of particular relevance; the claimed invention cannot be considered novel or cannot be considered to involve an inventive step when the document is taken alone
“E” earlier application or patent but published on or after the international filing date	“Y” document of particular relevance; the claimed invention cannot be considered to involve an inventive step when the document is combined with one or more other such documents, such combination being obvious to a person skilled in the art
“L” document which may throw doubts on priority claim(s) or which is cited to establish the publication date of another citation or other special reason (as specified)	“&” document member of the same patent family
“O” document referring to an oral disclosure, use, exhibition or other means	
“P” document published prior to the international filing date but later than the priority date claimed	

Date of the actual completion of the international search
 8 June 2016 (08-06-2016)

Date of mailing of the international search report
 13 June 2016 (13-06-2016)

Name and mailing address of the ISA/CA
 Canadian Intellectual Property Office
 Place du Portage I, C114 - 1st Floor, Box PCT
 50 Victoria Street
 Gatineau, Quebec K1A 0C9
 Facsimile No.: 819-953-2476

Authorized officer
 Casey Thomas (819) 639-7907

INTERNATIONAL SEARCH REPORT
Information on patent family members

International application No.
PCT/CA2016/000082

Patent Document Cited in Search Report	Publication Date	Patent Family Member(s)	Publication Date
US2495364A	24 January 1950 (24-01-1950)	None	
US2742264A	17 April 1956 (17-04-1956)	None	
US7237625B2	03 July 2007 (03-07-2007)	US2005230153A1 AU2003250644A1 AU2003250644B2 CA2493552A1 CA2493552C WO2004011764A1	20 October 2005 (20-10-2005) 16 February 2004 (16-02-2004) 02 August 2007 (02-08-2007) 05 February 2004 (05-02-2004) 12 October 2010 (12-10-2010) 05 February 2004 (05-02-2004)
US4359109A	16 November 1982 (16-11-1982)	None	
US4408570A	11 October 1983 (11-10-1983)	None	