



(12) **EUROPEAN PATENT APPLICATION**

(43) Date of publication:
08.12.2004 Bulletin 2004/50

(51) Int Cl.7: **G07F 7/06**

(21) Application number: **04012698.9**

(22) Date of filing: **28.05.2004**

(84) Designated Contracting States:
**AT BE BG CH CY CZ DE DK EE ES FI FR GB GR
HU IE IT LI LU MC NL PL PT RO SE SI SK TR**
Designated Extension States:
AL HR LT LV MK

(72) Inventor: **Sordella, Giacomo**
12038 Savigliano (Cuneo) (IT)

(74) Representative: **Buzzi, Franco**
Buzzi, Notaro & Antonielli d'Oulx S.r.l.
Via Maria Vittoria 18
10123 Torino (IT)

(30) Priority: **03.06.2003 IT TO20030408**

(71) Applicant: **LA BOITA S.r.l.**
I-12035 Racconigi (Cuneo) (IT)

(54) **Coin-operated lock for supermarket carts, luggage trolleys and the like**

(57) Coin-operated lock for supermarket carts, luggage trolleys and the like, comprising a case (1) with a slit (4) for the introduction/extraction of a coin or token (M) and an opening (5) for the introduction/extraction of

a key, and a mechanism housed inside the case (1) and formed by a single piece (7) able to achieve the locking, the unlocking and the extraction of the key (6) as well as to retain the coin or token (M) and to eject it.

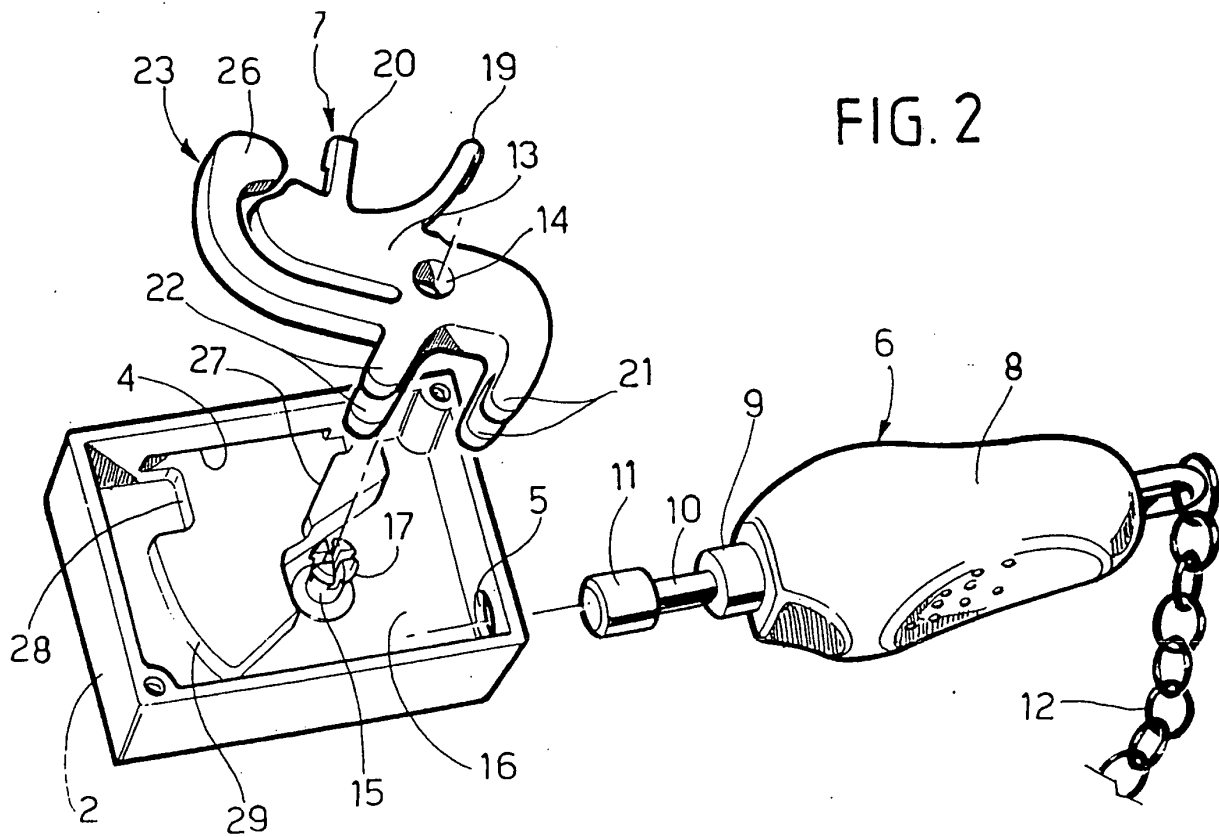

Description

[0001] The present invention relates to coin-operated locks for supermarket carts, luggage trolleys and the like, serving the function of securing, typically by means of chains, the carts arranged consecutively in rows, and to allow their withdrawal by users only as a result of the introduction of a coin or token into the coin-operated lock. The coin-operated lock can also secure the cart to a fixed body, instead of to an adjacent cart.

[0002] Such coin-operated locks traditionally comprise a case having a slit for the introduction/extraction of the coin or token, and an opening for the introduction/extraction of the key. Inside the case is housed a mechanism comprising the following elements:

- means for locking the key, movable between an operative position of locking the key inserted in said opening and an inoperative position of unlocking for freeing the extraction of the key from said opening,
- actuator means operated by effect of the insertion of the coin or token into said slit to actuate the displacement of said locking means from said operative position to said inoperative position,
- means for extracting the key as a result of the displacement of said means for locking from said operative position to said inoperative position,
- retaining means for holding the coin or token within the case as a result of the displacement of said locking means to the inoperative position,
- means for disengaging the means for retaining the coin or token, operated by effect of the insertion of the key into said opening, and
- means for ejecting the coin or token through said slit as a result of the operation of said disengagement means.

[0003] Coin-operated locks of this kind are known, for example, from the patent document EP-A-1035523 by SYSTEC, as well as from documents GB-A-2276482 and DE-A-19720557.

[0004] In all these known solutions, the coin-operated lock mechanism comprises a plurality of distinct elements assembled within the case, which are most metallic and include one or more springs.

[0005] These solutions are all extremely complicated, both from the viewpoint of fabrication and with regard to the assembly of their components, and thus are costly. Moreover, most of such known coin operated locks are heavy and above all bulky, because of the dimensions of the related cases, necessary to contain the various components of the mechanisms. The coin operated lock according to the aforementioned patent document EP-A-1035523 by SYSTEC has relatively limited bulk, but does not solve the problems connected with complexity and construction and costs.

[0006] Normally, coin operated locks are applied on the front side of the cart, at a bar that constitutes a thrust

handle: the bulk of known coin operated locks is ill suited with the need to use the thrust bar for the application, according to current tendencies, of accessories such as, in particular, displays of information for the user.

[0007] The object of the present invention is to overcome the aforesaid drawbacks, and to provide a coin operated lock of the type described above whose mechanism has an extremely simplified arrangement, totally lacking metallic springs, and that is simple and economical to fabricate and has very limited bulk, thereby drastically reducing the dimensions of the case and hence of the coin operated lock as a whole.

[0008] According to the invention, said object is achieved thanks to the fact that the aforesaid means for locking the key, the aforesaid actuator means, the aforesaid means for retaining the coin or token and the aforesaid disengagement means are formed in a single piece.

[0009] Advantageously, also the aforesaid means for extracting the key and/or the aforesaid means for expelling the coin or token are formed in a single piece with said means for locking the key, said actuator means, said means for retaining the coin or token and said disengagement means.

[0010] According to a preferred embodiment of the invention the aforesaid single piece is constituted by a body made of moulded plastic material, oscillating about a single rotation pivot. Said pivot is preferably but not necessarily borne by the case.

[0011] The actuator means conveniently coincide with the means for ejecting the coin or token and advantageously consist of an elastically springing arm of said single piece, which is integrally formed with an abutment with which co-operates a complementary stop formed in said case to retain the means for locking the key in the operative position; said abutment being disengageable from said complementary stop by the coin or token as a result of its introduction into the slit of the case, and being re-engageable with said complementary stop upon extraction of said coin or token relative to said slit.

[0012] The means for locking the key can consist of at least one hook-shaped appendage of said single piece, engageable with an abutment part of the key as a result of its insertion into the opening of the case. According to an optional characteristic of the invention, said abutment part of the key is formed by a generally cylindrical head, and the locking means include a pair of said hook appendages substantially configured in the manner of a fork for the engagement of said cylindrical head. In this way, the key can advantageously be introduced into the coin operated lock without a predetermined orientation, i.e. in any angular position relative to its direction of introduction into the opening of the case.

[0013] Additional characteristics and advantages shall become readily apparent from the description that follows with reference to the accompanying drawings, provided purely by way of non limiting example, in which:

- Figure 1 is a perspective schematic view of a coin operated lock for carts according to the invention,
- Figure 2 is an exploded partial perspective view of the coin operated lock, which shows its inner mechanism together with a particular key, usable with said mechanism,
- Figures 3 and 8 schematically show elevation views of the operation of the mechanism of the coin operated lock respectively during the introduction of the coin or token to obtain the extraction of the key (Figures 3, 4 and 5) and during the introduction of the key to obtain the extraction of the coin or token (Figures 6, 7 and 8),
- Figure 9 shows a perspective side view of the single piece constituting the mechanism of the coin operated lock,
- Figure 10 shows a perspective view of the single piece of Figure 9 from the other side, and
- Figure 11 is a variant of Figure 9.

[0014] Referring initially to Figure 1, a coin-operated lock for supermarket carts, luggage trolleys and the like according to the invention comprises a case 1 formed by a small, flattened parallelepiped box including a base 2 and a lid 3.

[0015] The box 1 has a slit 4 for the introduction/extraction of a coin or token designated by the reference M in Figures 3-8, and an opening 5 for the introduction/extraction of a key generically designated by the reference 6 in Figures 2-8.

[0016] In the case of the illustrated example, and in consideration of the conformation of the key 6 which shall be described below, the opening 5 is formed by a circular hole, and said hole is positioned on one of the smaller lateral walls of the case 1, whilst the slit 4 is positioned on another one of the smaller lateral walls of said case 1. More specifically, in the illustrated example the case 1 of the coin-operated lock is applied to a cart, advantageously in the area of its thrust bar, in the position shown in Figure 1, i.e. with the slit 4 in the upper lateral wall. In this case, the wall of the case 1 bearing the hole 5 is the dorsal one, i.e. the one oriented towards the rear side of the cart.

[0017] With this arrangement, as shall become more readily apparent below, the direction of introduction/extraction of the coin or token M and of the key 6, respectively designated by the arrows F and H in Figures 3-8, are substantially orthogonal to each other or, more properly, positioned obliquely. However, this is not at all necessary, since such directions may differ from those shown.

[0018] The case 1 contains a mechanism whereby when the key 6 is inserted in the hole 5, the introduction of the coin or token M through the slit 4 causes its extraction and, vice versa, when the coin or token M has been inserted in the case 1 through the slit 4, the introduction of the key 6 in the hole 5 causes its extraction.

[0019] According to the essential characteristic of the

invention, said mechanism is in practice constituted by a single piece, advantageously of moulded plastic material, globally designated by the reference 7.

[0020] The embodiment of the piece 7 that shall be described below is the one corresponding to a particular and innovative conformation of the key 6 which, as shown in the drawings, consists of a grip body 8 from an end whereof projects a cylindrical element 9 followed by a cylindrical tang of lesser diameter 10 bearing an end head 11, also cylindrical, of greater diameter. The diameter of the cylindrical head 11 is slightly smaller than that of the hole 5, to allow its passage through said hole. The grip body 8 bears, at the opposite end, a chain 12 which is also advantageously made of plastic material, serving to anchor the key 6 to another cart.

[0021] With such a configuration, the key 6 is able to operate the coin-operated lock without the user's having to be concerned with introducing it through the hole 5 in a particular angular position, as is the case instead with traditional keys which, instead of the cylindrical head 11, are provided with a holed plate or the like. However, as shall be seen below, even such a traditional key may be used with the coin-operated lock according to the invention: in this case, the circular hole 5 shall be replaced by a slit or the like.

[0022] With express reference to the use with the key 6 described above, the piece 7 which forms the coin-operated lock mechanism in a single piece comprises a central body 13 having a through hole 14, rotatably engageable on a pivot 15 projecting from the larger wall 16 of the base 2 of the case 1. The pivot 15 projects perpendicularly to the wall 16, integrally therewith, and is advantageously formed at its free end with a terminal 17 capable of contracting elastically in sectors which, when the piece 7 is mounted, is able axially to traverse its hole 14, engaging then in snap-on fashion beyond it. However, this characteristic is optional. Moreover, the pivot 15 could be borne, instead of by the case 1, by the piece 7 (for example, integrally therewith) and could rotatably engage a corresponding support or hole in the case.

[0023] It should be stated that the term "upper", "lower", "front" and "rear" and the like as used hereinafter are understood to refer to the position of the piece 7 within the case 1 in the condition of employment of the coin-operated lock in which the slit 4 is oriented upwards and the opening 5 is positioned posteriorly, with particular reference to Figures 9 and 10 the piece has the following integral parts:

- a cradle shaped seat 18 to receive a coin or token M in support, formed laterally and anteriorly to the central body 13;
- a first and a second arm 19, 20 for securing the coin or token M operatively associated at the side of the cradle seat 18 and projecting upwards with respect thereto;
- a pair of rear appendages 21 projecting below the

- central body 13 and defining a latching fork;
- a pair of central appendages 22, also projecting inferiorly to the central body 13, aligned with the latching appendages 21 and constituting a thrust device;
- an elongated springing arm 23 having a general L shape and projecting anteriorly to the central body 13, with an arm 24 of greater length springing underneath the cradle seat 18 and an arm with smaller length 25 folded anteriorly to said cradle seat 18 and whose free end is formed with a rounded abutment enlargement 26.

[0024] The variant of the piece 7 shown in Figure 11 corresponds to the configuration thereof that is usable with a traditional key, or with holed engagement plate: in this case, the piece 7 differs from the one described previously solely because it has a single latching appendage 21 and a single thrust appendage 22, which in this case, too, are aligned to each other.

[0025] To the mechanism of the coin-operated lock constituted by the piece 7 described above is operatively associated a formation provided, within the case 1, on the wall 16 of the base 2. Said formation essentially comprises three components: an inclined slide projection 27, situated below the rear end of the slit 4, an arresting seat 28 positioned below the front end of the slit 4, and an arched track 29 extending below the arresting recess 28. As will be seen below, the arresting recess 28 and the track 29 co-operate with the terminal abutment 26 of the springing arm 23 of the piece 7.

[0026] In the assembled condition of the coin-operated lock the piece 7 is mounted oscillating, as explained previously, on the pivot 15, whose axis is orthogonal to the directions of introduction/extraction F of the coin or token M and H of the key 6. The cradle-like seat 18 of the piece 7 is oriented towards the wall 16 of the base 2, i.e. towards the inclined guiding slide 27, and it is positioned below the slit 4, whilst the latching appendages 21 are oriented towards the hole 5.

[0027] Referring now to Figures 3-5 and 6-8, the operation of the coin-operated lock according to the invention shall be described.

[0028] It is supposed that the initial position, shown in Figure 3, is one in which the key 6 is engaged and locked in the coin-operated lock, by effect of the engagement of its cylindrical head 11 by the appendages 21 of the piece 7. The cylindrical head 11 is interposed between the latching appendages 21 and the thrust appendages 22, and the springing arm 23 is in a non-deformed position with its end abutment 26 engaged within the stopping recess 28. In this way, the piece 7 is locked in rotation relative to the case 1, thereby preventing by means of the latching appendages 21 the disengagement of the cylindrical head 11 and the extraction of the key 6 from the hole 5.

[0029] To allow the extraction of the key 6, in order to allow the removal of the cart whereon the coin-operated is installed in use, the coin or token M must be intro-

duced through the slit 4. The introduction of the coin M is conveniently performed from above, at first by simple gravity and then by means of a thrust operated manually downwards. By effect of said thrust, the coin M is made to roll or slide along the inclined guiding slide 27 in the direction of insertion F. Said direction of insertion F is clearly directed obliquely, parallel to the slide 27, so that during its insertion the coin M moves towards the front end of the slit 4, intercepting with its lateral edge the end abutment 26 of the springing arm 23 in the manner shown in Figure 4. In this way, continuing the insertion of the spring M in the case 1, the end abutment is disengaged by the arresting recess 28, by effect of the elastic deformation of the springing arm 23. This condition substantially occurs when the coin M is positioned on the cradle-like seat 18.

[0030] Starting from said position, the piece 7, no longer locked in rotation by the engagement between the end abutment 26 and the arresting recess 28, rotates about the axis of the pivot 15 counter-clockwise with reference to the figures, under the thrust applied to the coin M during the last phase of its introduction through the slit 4. By effect of said rotation, during which the end abutment 26 moves freely along the arched track 29 with the springing arm 23 not stressed and hence not deformed, the coin M is entirely positioned below the front end of the slit 4, whilst simultaneously the latching appendages 21 free the cylindrical head 11 of the key 6 and the appendages 22 apply to said head 11 a thrust in the direction of the opening 5.

[0031] At the end of this phase, shown in Figure 5, the key 6 can be extracted from the case 1 through the opening 5, freeing the coin-operated lock and hence allowing the removal of the cart. The coin or token M remains positioned within the case 1 both by gravity, and by the presence of the securing arm 19 which does not allow it to exit from the slit 4. The other securing arm holds the coin M against the wall 16 of the base 12, preventing it from being subjected to skipping within the case 1 during the movements of the cart whereon the coin-operated lock is applied.

[0032] At the end of the use of the cart, to recover the coin M it is necessary to re-insert the key 6 into the case 1 of the coin-operated lock. When the cylindrical head 11 traverses the opening 5, it intercepts the thrust appendages 21, in the manner shown in Figure 6. An additional thrust applied to the key 6 towards the interior of the coin-operated lock causes, by effect of the interaction between the head 11 and the thrust appendages 22, the piece 7 to rotate clockwise with reference to the figures. By effect of said rotation, the coin M is thrust on the inclined slide 27 towards the slit 4, whilst simultaneously the latching appendages 21 engage behind the head 11. The extraction of the coin or token M through the slit 4 is operated not only by the clockwise rotation of the piece 7, but also by the thrust action operated by the end abutment 26 when, during the rotation, it intercept the lateral edge of the coin M. When said end abut-

ment 26, at the end of its displacement along the track 29, reaches the arresting recess 28, it is engaged in snap-on fashion within said recess 28 by effect of the elastic deformation of the springing arm 23 and of its subsequent immediate return to the undeformed position, in the manner shown in Figure 7, possibly operating a more or less marked elastic ejection effect on the coin M. It should be noted that said engagement, thanks to the rounded conformations of the abutment 26 and of the part of the track 29 that is adjacent to the recess 28, occurs smoothly and with reduced wear of said parts.

[0033] The key 6 is thus blocked relative to the case 1, whilst the coin M can be withdrawn and extracted manually through the slit 4. This manoeuvre can be facilitated by applying an additional thrust on the key 6 towards the interior of the coin-operated lock, in such a way as to obtain a clockwise angular extra-travel of the piece 7 lifting the cradle-like seat 18 towards the slit 4 and, consequently, the coin M upwards. To allow said additional angular rotation of the piece 7, it will naturally be necessary for the arresting recess 28 to be larger than the end abutment 26.

[0034] It will be readily apparent from the previous description that the piece 7, which can be fabricated and assembled with the case 1 in extremely simple and economical fashion, in practice groups all the operative components of the mechanism of the coin-operated lock, i.e. the means for locking the key (latching appendages 21) and the related actuator means to actuate its unlocking (spring arm 23 and related end abutment 26), the means for retaining the coin or token M (seat 18 and securing arms 19, 20), the means for extracting the means for retaining the coin or token M (thrust appendages 22) which also operate as means for extracting the key 6, and the means for ejecting the coin or token M (also constituted by the springing arm 23 with the end abutment 26). Said operative components thus grouped in the piece 7 co-operate with the simple formations provided in the wall 16 of the case 1 (pivot 15, guiding slide 27, arresting recess 28 and track 29) to complete the operativeness of the mechanism, in equally simple and economical fashion from the construction point of view. The entire coin-operated lock can thus be advantageously obtained by moulding plastic material, with the exclusion of any metallic parts and in particular of springs, in just three parts: the case 1 formed by the base 2 with the pivot 15 and by the lid 3, and the piece 7.

[0035] Naturally, the construction details and the embodiments may vary widely from what is described and illustrated herein, without thereby departing from the scope of the present invention as defined in the claims that follow. Thus, as clarified above, the piece 7 may be adapted for use with traditional keys, and it may be formed with the pivot 15, also integrally. Moreover, the positions of the slit 4 and of the opening 5 may be different from those illustrated, and such that the direction of insertion/extraction F and H respectively of the coin or token M and of the key 6 are different from those de-

scribed with reference to the example. In any case, preferably said directions will not be mutually aligned as is normally the case in conventional coin-operated locks.

[0036] Lastly, it should be noted that the engagement between the abutment 26 of the springing arm 23 and the seat 28 of the case 1, in the inserted condition of the key 6 in the absence of the coin or token M, may be such that, if a force exceeding a threshold value is applied to extract the key, the piece 7 is freed in rotation in order to disengage the key and safeguard the lock-chain-cart system from breakage.

Claims

1. A coin-operated lock for supermarket carts, luggage trolleys and the like, comprising a case (1) having a slit (4) for the introduction/extraction of a coin or token (M) and an opening for the introduction/extraction of a key (6), and a mechanism housed inside the case and including:

- means (21) for locking the key (6) movable between an operative position for locking the key (6) inserted in said opening (5) and an inoperative, unlocking position to free the extraction of the key (6) from said opening (5),
- actuator means (23, 26) operated by effect of the insertion of the coin or token (M) into said slit (4) to actuate the displacement of said locking means (21) from said operative position to said inoperative position,
- means (22) for extracting the key (6) as a result of the displacement of said locking means (21) from said operative position to said inoperative position,
- retaining means (18, 19, 20) to hold said coin or token (M) in the case (1) as a result of the displacement of said locking means (21) to the inoperative position,
- means (22) for disengaging said means (18, 19, 20) for retaining the coin or token (M) operated by effect of the introduction of the key (6) into said opening (5), and
- means (23, 26) for ejecting the coin or token (M) through said slit (4) as a result of the operation of said disengagement means (22),

characterised in that said means (21) for locking the key (6), said actuator means (23, 26), said means (18, 19, 20) for retaining the coin or token (M) and said disengagement means (22) are formed in a single piece (7).

2. Coin-operated lock as claimed in claim 2, **characterised in that** said means (22) for extracting the key (6) are formed in a single piece (7) with said locking means (21), said actuator means (23, 26),

said retaining means (18, 19, 20) and said disengagement means (22).

3. Coin-operated lock as claimed in claim 1 or in claim 2, **characterised in that** said means (23, 26) for ejecting the coin or token (M) are formed in a single piece (7) with said locking means (21), said actuator means (23, 26), said retaining means (18, 19, 20) and said disengagement means (22). 5
4. Coin-operated lock as claimed in any of the claims 1 through 3, **characterised in that** said single piece (7) is capable of oscillating around a rotation pivot (15). 10
5. Coin-operated lock as claimed in any of the previous claims, **characterised in that** said single piece (7) is integrally formed with a reception seat (18) for the coin or token (M) introduced into said slit (4). 15
6. Coin-operated lock as claimed in claim 5, **characterised in that** said reception seat is shaped as a cradle (18). 20
7. Coin-operated lock as claimed in claim 5 or claim 6, **characterised in that** said means for retaining the coin or token (M) comprise at least one securing arm (19, 20) operatively associated to said reception seat (18). 25
8. A coin-operated lock as claimed in claim 5 or claim 6, **characterised in that** with said reception seat (18) co-operates an inclined guiding slide (27) formed within said case (1) in correspondence with said slit (4). 30
9. A coin-operated lock as claimed in claim 8, **characterised in that** said inclined guiding slide (27) determines a direction of introduction/extraction (F) of the coin or token (M) directed obliquely with respect to said slit (4). 35
10. Coin-operated lock as claimed in claim 2, **characterised in that** said actuator means (23, 26) coincide with said means (23, 26) for ejecting the coin or token (M). 40
11. Coin-operated lock as claimed in claim 10, **characterised in that** said actuator means and said ejection means are constituted by an elastically springing arm (23). 45
12. Coin-operated lock as claimed in claim 1, **characterised in that** said springing arm (23) is formed integrally with a terminal abutment (26) with which co-operates a complementary stop (28) formed in said case (1) to hold said means (21) for locking the key (6) in said operative position; said end abutment

(26) being disengageable from said complementary stop (28) by the coin or token (M) as a result of its introduction into said slit (4) and being re-engageable with said complementary stop (28) when said coin or token (M) is extracted relative to said slit (4).

13. A coin-operated lock as claimed in any of the previous claims, **characterised in that** said means for locking the key (6) consist of at least one hook appendage (21) of said single piece (7), engageable with an abutment part (11) of said key (6) as a result of its insertion through said opening (5).
14. Coin-operated lock as claimed in claim 13, **characterised in that** said locking means include a pair of said hook appendages (21) substantially configured in the form of a fork (21).
15. Coin-operated lock as claimed in claim 13 or claim 14, **characterised in that** said means for extracting the key (6) and said means for disengaging said means (18, 19, 20) for retaining the coin or token (M) consist of at least one thrust appendage (22) of said single piece (7).
16. A coin-operated lock as claimed in claim 15, **characterised in that** said at least one thrust appendage (22) is aligned with said at least one hook appendage (21) along the direction of introduction/extraction (H) of the key (6).
17. A coin-operated lock as claimed in claim 15 or claim 16, **characterised in that** said at least one thrust appendage (22) is adapted to command, by means of said key (6), an extra travel of said ejection means (23, 26) to facilitate the extraction of the coin or token (M) from said slit (4).
18. Coin-operated lock as claimed in claim 4, **characterised in that** said rotation pivot (15) is formed integrally with one of said case (1) and single piece (7).
19. Coin-operated lock as claimed in claim 4 or claim 18, **characterised in that** said rotation pivot (15) is provided with a rotatable rapid coupling formation for said single piece (7).
20. Coin-operated lock as claimed in one or more of the previous claims, **characterised in that** said case (1) is formed in the form of a flattened generally parallelepiped box.
21. Coin-operated lock as claimed in claim 20, **characterised in that** said slit (4) for the introduction/extraction of the coin or token (M) is formed on an upper wall of said box (1) and said opening (5) for the introduction/extraction of the key (6) is formed on a

lateral wall of said box (1).

22. Coin-operated as claimed in any of the previous claims, **characterised in that** said single piece (7) is made of moulded plastic material. 5
23. A key (6) usable in a coin-operated lock as claimed in claim 14, **characterised in that** it is formed with a generally cylindrical head (11) which constitutes said abutment part able to be engaged by said hook appendages (21) for locking the key (6) inserted in said opening (5) of the case (1) of the coin-operated lock. 10
24. Coin-operated lock as claimed in any of the claims 1 through 22, **characterised in that** it is associated to a key as claimed in claim 23. 15
25. A supermarket cart, luggage trolley and the like, **characterised in that** it is equipped with a coin-operated lock as claimed in any of the claims 1 through 22 and 24. 20
26. A supermarket cart, luggage trolley and the like, **characterised in that** it is equipped with a key as claimed in claim 23. 25

30

35

40

45

50

55

FIG. 1

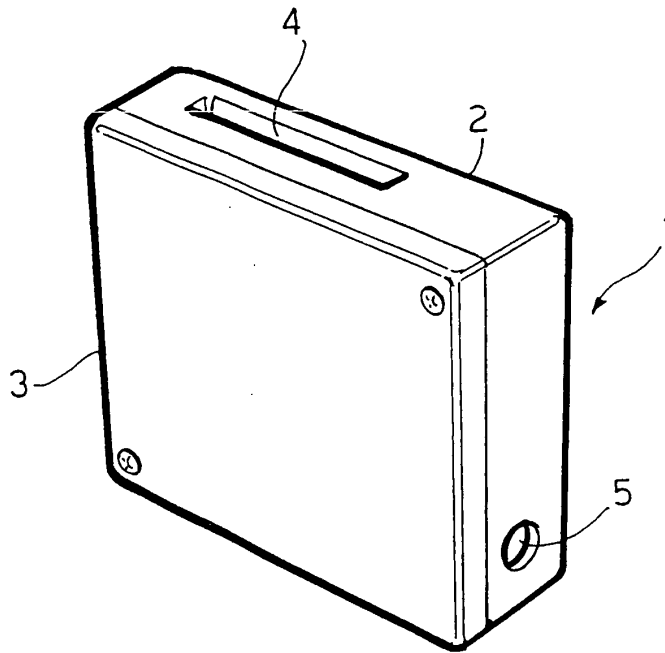
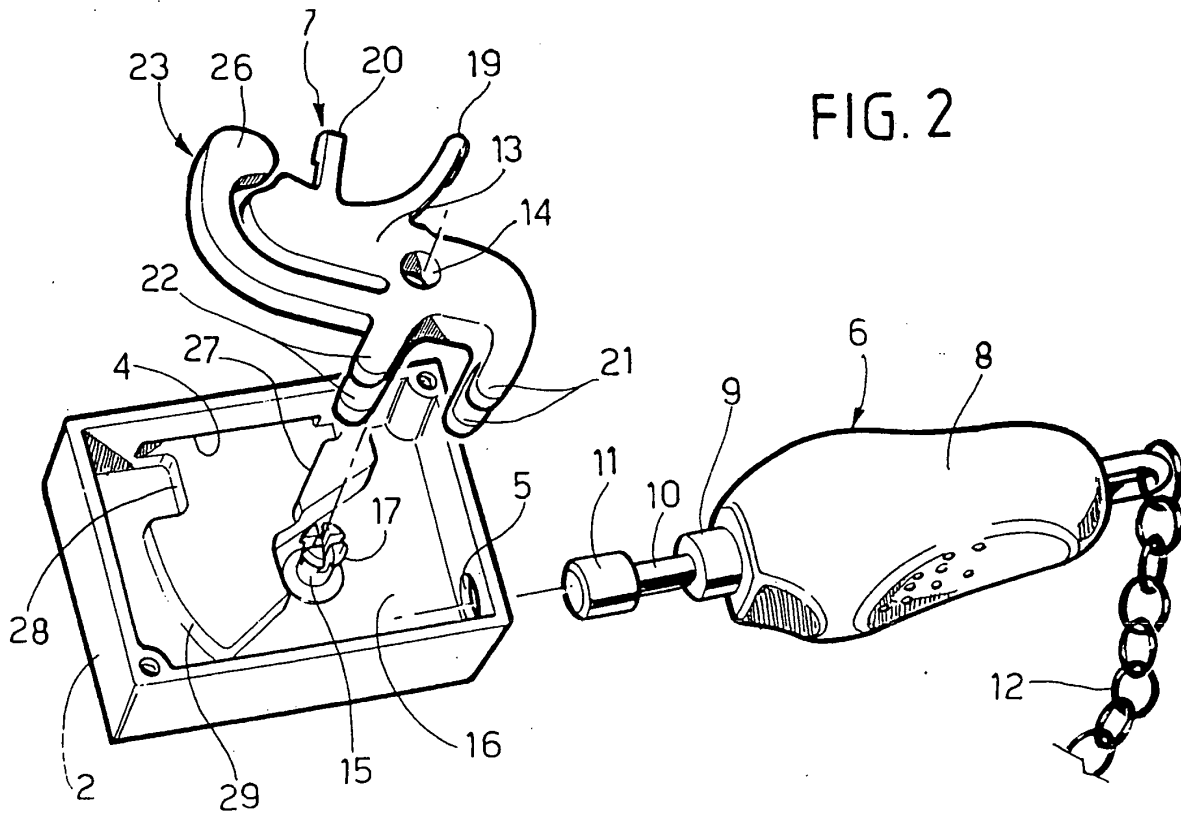
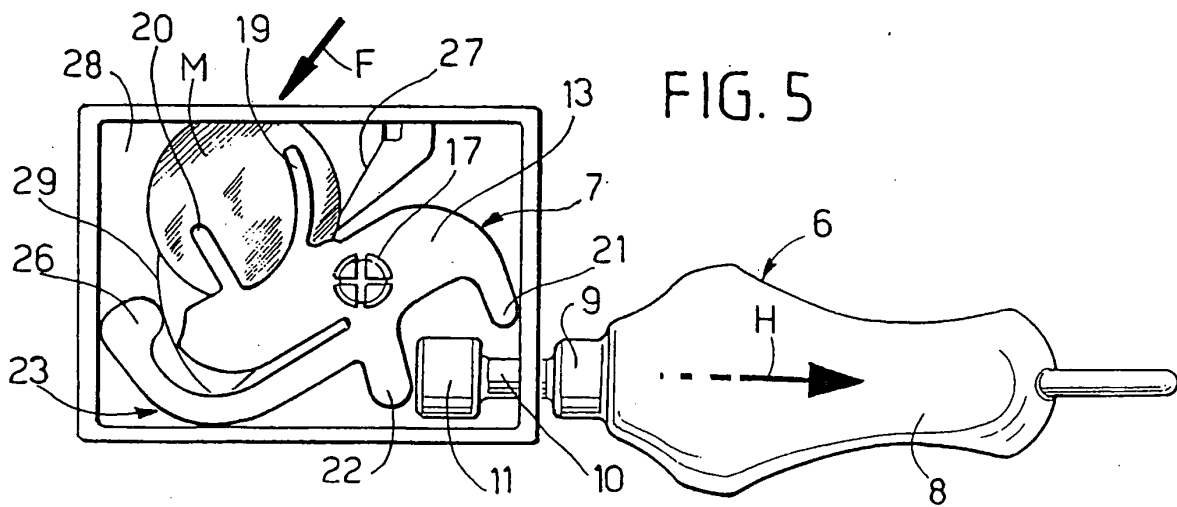
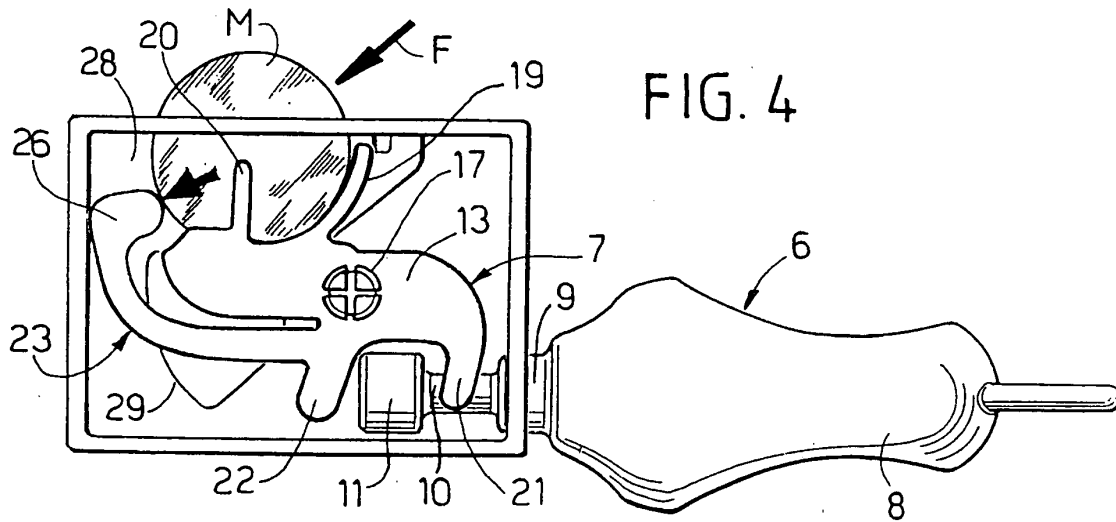
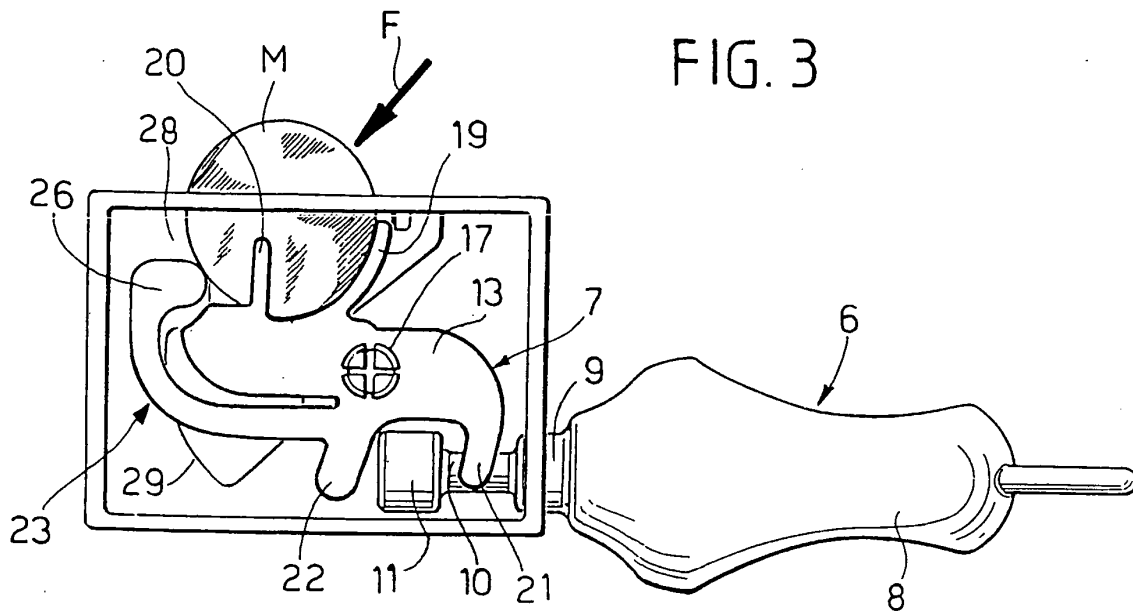

FIG. 2





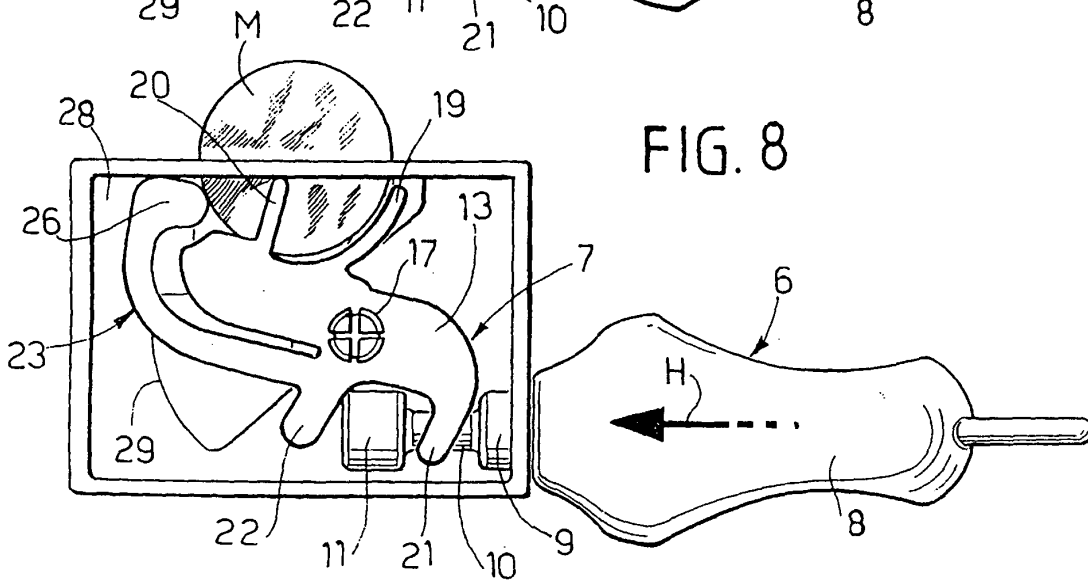
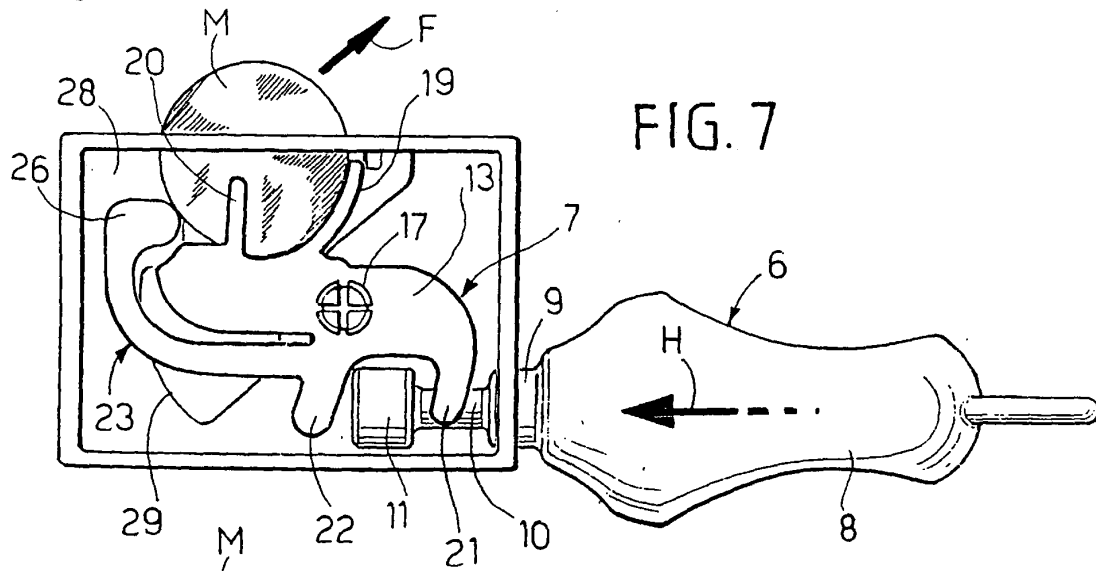
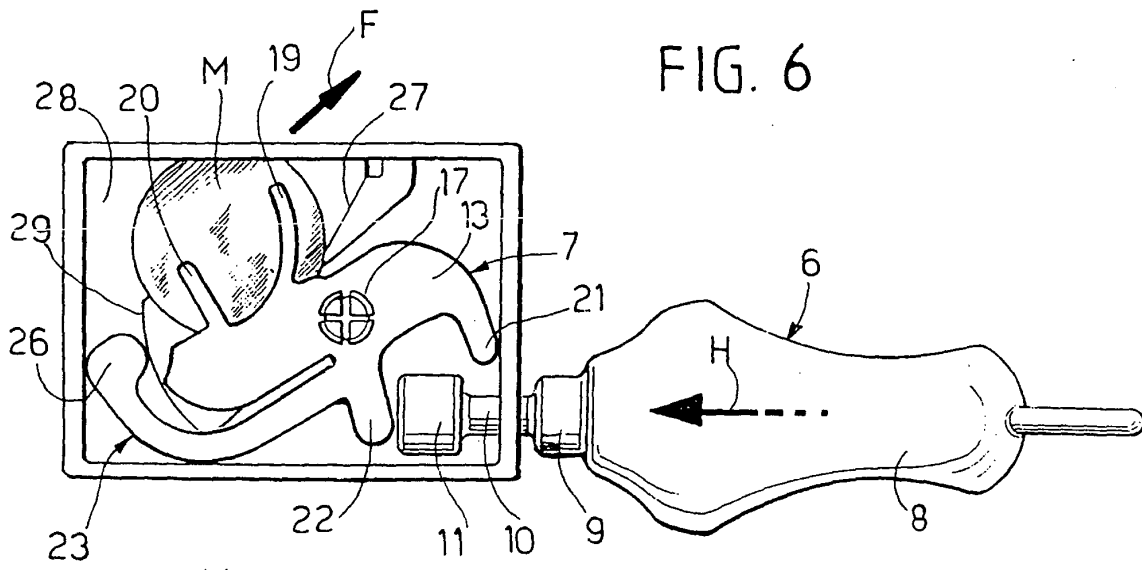

FIG. 9

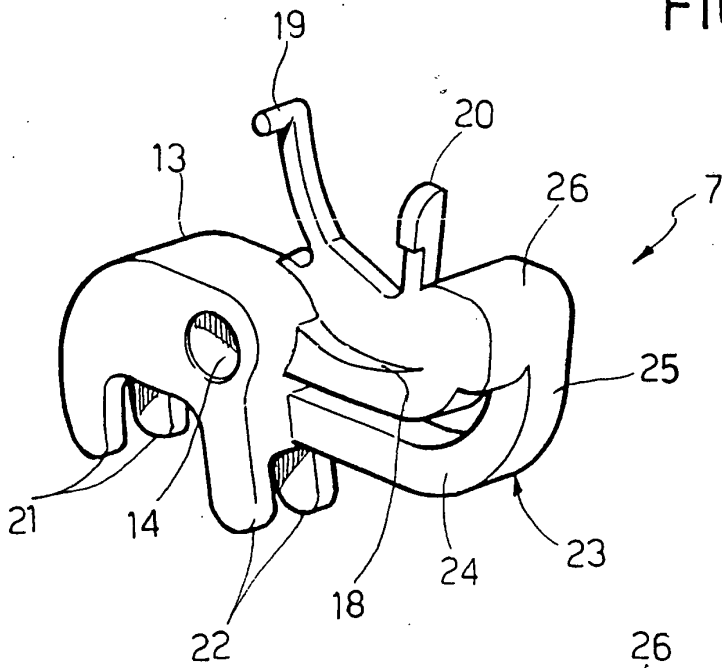

FIG. 10

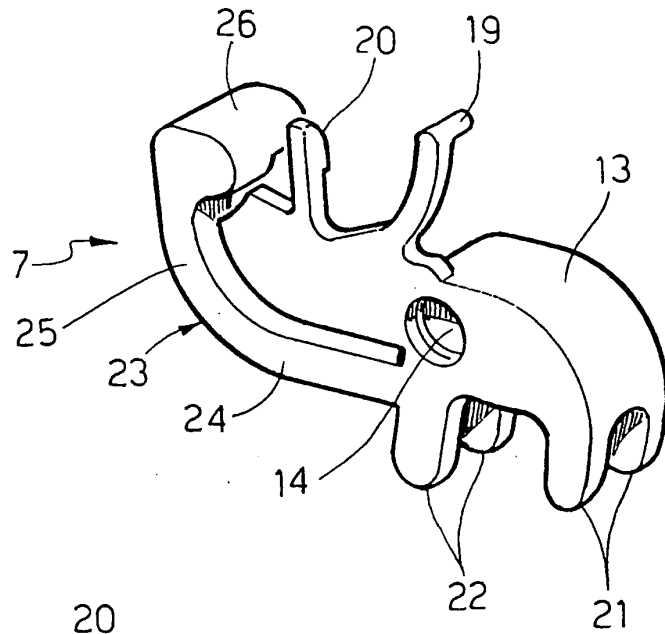

FIG. 11

