

(No Model.)

2 Sheets—Sheet 1.

A. AU.
SCRUBBING MACHINE.

No. 524,751.

Patented Aug. 21, 1894.

Fig I.

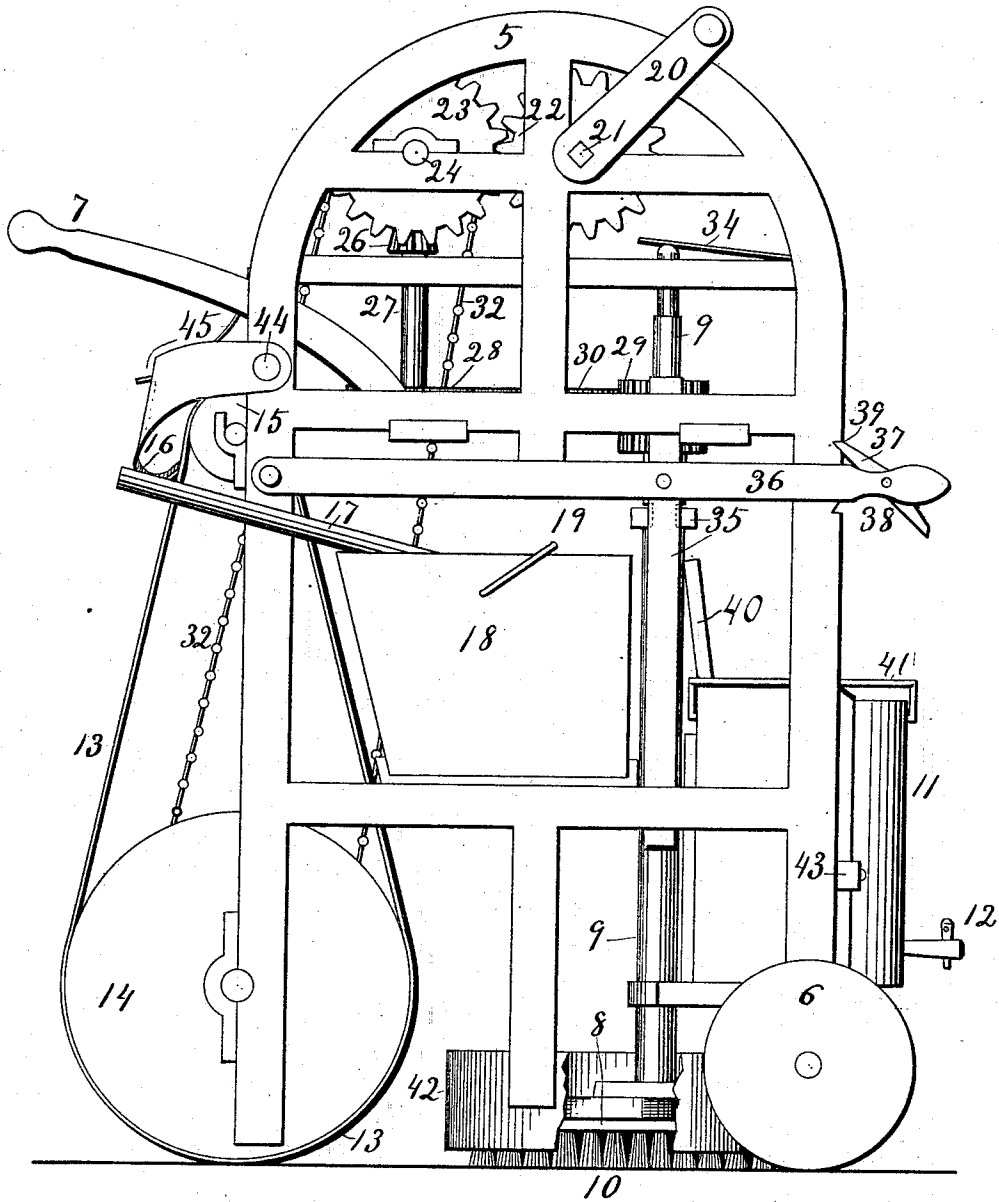

WITNESSES,
P. Egbert Stevens
M. C. Willyard.

INVENTOR,
Anton A. U.
by *W. C. Stevens* ATTORNEY.

(No Model.)

2 Sheets—Sheet 2.

A. A U.
SCRUBBING MACHINE.

No. 524,751.

Patented Aug. 21, 1894.

Fig II.

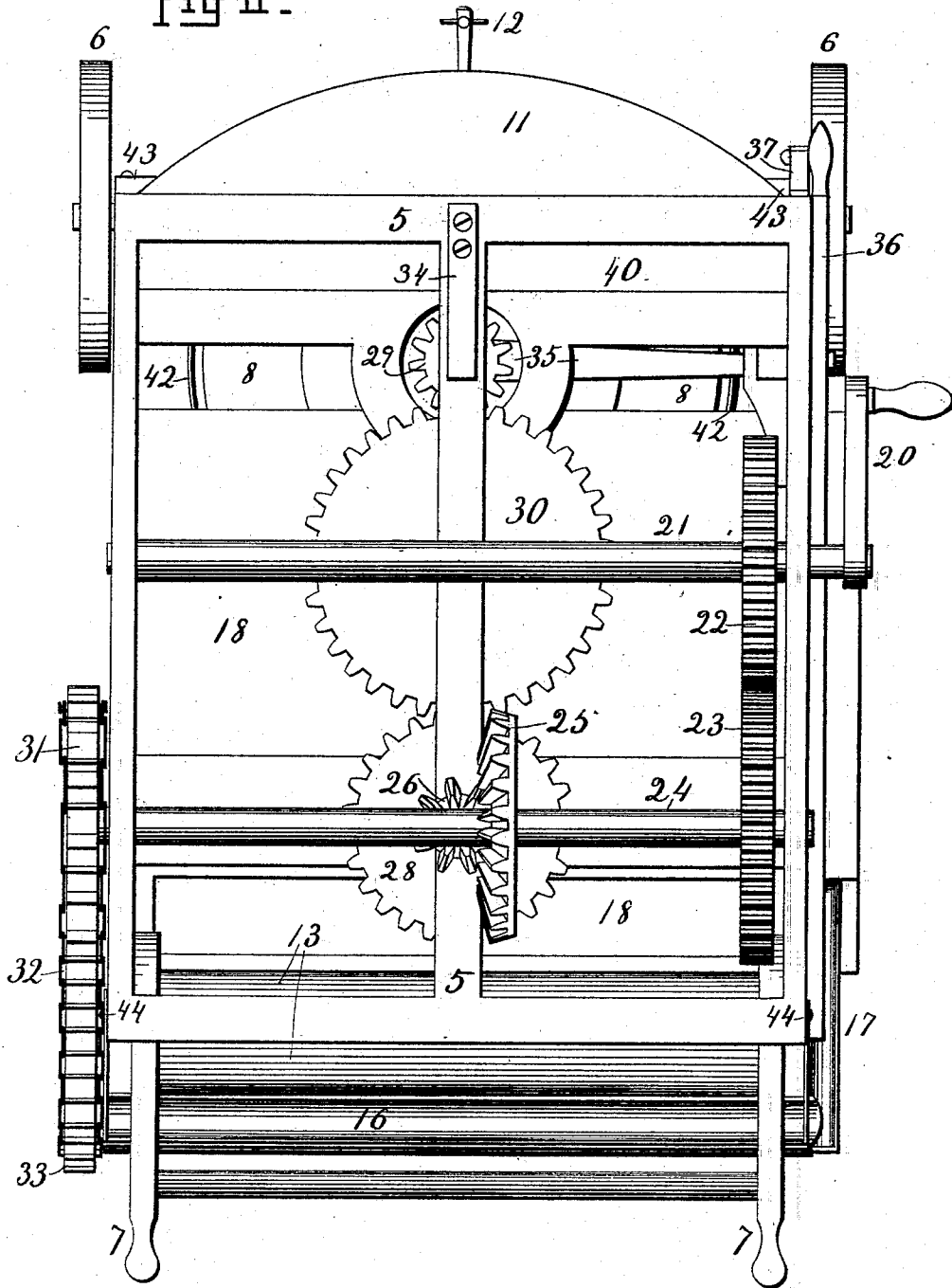

WITNESSES.

P. Egbert Stone.
M. C. Willyard.

INVENTOR.

Anton A. U.
by W. S. Stevens ATT'Y.

UNITED STATES PATENT OFFICE.

ANTON AU, OF CRANDON, SOUTH DAKOTA.

SCRUBBING-MACHINE.

SPECIFICATION forming part of Letters Patent No. 524,751, dated August 21, 1894.

Application filed April 28, 1894. Serial No. 509,380. (No model.)

To all whom it may concern:

Be it known that I, ANTON AU, a citizen of the United States, residing at Crandon, in the county of Spink and State of South Dakota, have invented certain new and useful Improvements in Floor-Scrubbing Machines; and I do hereby declare the following to be a full, clear, and exact description of the invention, such as will enable others skilled in the art to which it appertains to make and use the same.

This invention relates to machines which are used for scrubbing floors, and its objects are to revolve a brush or series of brushes bearing upon the floor; to deliver clean water ahead of the brush; to gather up the dirty water behind the brush and to wipe the floor so as to quickly clean and dry it.

To these ends my invention consists in the construction and combination of parts forming a floor scrubbing machine, hereinafter described and claimed, reference being had to the accompanying drawings, in which—

Figure I, is a side elevation of a scrubbing machine according to my invention, certain parts being broken away. Fig. II, is a top view of the same.

5 represents the frame of the machine mounted to travel on a pair of wheels 6 at its forward end, and provided with handles 7, by means of which it may be propelled and guided around over the floor.

8 represents the scrubber consisting of a head mounted upon a shaft 9 which is journaled vertically in bearings in the frame. This scrubber may have a single brush, or it may be provided with a number of brushes 10, fixed radially or in any slanting position desired upon the lower face thereof.

11 represents a tank for carrying clean water. It is removably located in the forward part of the frame and provided with a faucet 12 arranged to deliver water in front of the scrubber. This faucet may be set so as to drip the water slowly or it may be left farther open to deliver more water according as it may be required.

13 represents a mopping belt made of thick material adapted to soak up water. It is mounted upon the drum 14 and a pulley 15 to be rotated rubbing upon the floor against the direction of travel of the machine.

16 is a trough located with one edge bearing closely against the mopping belt to scrape therefrom the surplus water and the free dirt carried thereby. This trough slants a little to one side and is provided with a delivery spout 17 at that side to convey the dirty water into a tank 18. This tank is provided with a bail 19 whereby it may be drawn out from the frame and carried away to be emptied.

20 is a hand crank whereby both the scrubber and the mopping belt are rotated in service. This crank is mounted upon a shaft 21, which is provided with a gear wheel 22, adapted to engage a gear wheel 23, on another shaft 24, upon which is mounted a beveled gear 25, which engages a beveled gear 26 on a vertical shaft 27.

28 is a gear wheel fixed upon the shaft 27 and connected with a pinion 29 on the scrubber shaft 9 by means of an intermediate gear wheel 30.

31 is a sprocket wheel mounted upon the shaft 24, and 32 is a chain connecting this wheel with a sprocket wheel 33 which is fixed to the shaft of the drum 14. The shaft 9 is fitted to slide vertically in its bearings, and 34 is a spring pressing upon its end to impel the brushes downward upon the floor while at work.

35 is a shifter connected with a groove in the shaft 9 and provided with a lever handle 36 whereby it may be raised to lift the scrubber entirely free from the floor when the machine is being rolled from place to place, and 37 is a latch adapted to engage an upward facing notch 38 in the frame to hold the scrubber raised.

39 is a downward facing notch which may be engaged by the same latch to hold the lever 36 and the scrubber down when it is desired to press very hard upon the floor.

The tank 11 is provided with a convenient lid 40, and with a bail 41 whereby it may be carried to be filled.

42 is a fender made of sheet metal and located around the scrubber at a little distance therefrom, where it is held suspended from the frame to protect the mop-board and other objects which the scrubber may pass by when at work, from being spattered.

43 represent buttons on the frame projecting over the edges of the tank 11 to retain it

in place. The mopping belt may be of one or more thicknesses of any absorbent material suitable for this purpose.

5 The pinion 29 is vertically elongated in order that it may continue to engage the intermediate gear wheel 30 whether the scrubber be raised or lowered while in operation.

10 The absorbent nature of the mopping belt 13 tends to soak up the water and by being revolved to rub upon the floor against the direction of travel of the machine, its tendency is to rub the floor clean and leave it entirely free of standing water.

15 The trough 16 hanging from pivots 44 and further pressed by a spring 45 bears against the face of the mopping belt enough to press it somewhat out of line thereby serving as a scraper to strip off any loose particles which may be picked up by the belt, and to squeeze out the dirty water therefrom.

20 In operating this machine it may be stood over any particularly dirty spot and there the brushes may be revolved as long as required to do the cleaning.

25 By bearing much or little on the handles the mopping belt may be rubbed hard or lightly upon the floor.

Having described my invention, what I

claim as new, and desire to secure by Letters Patent, is—

30 1. The combination in a floor scrubbing machine, of a brush mounted on a vertical shaft in a frame and means for rotating it; a shifter connected with the shaft; an operating lever for the shifter; a reversible latch 35 on the lever and notches in the frame facing upward and downward to be engaged by the latch, substantially as described.

40 2. The combination of a floor scrubbing machine frame mounted on wheels; a water tank having a delivery faucet at its front end; a scrubber behind the tank delivery; a mopping belt mounted to rub on the floor to the rear of the scrubber; a scraping trough hung 45 thereon, a delivery spout from the trough; a tank to receive dirty water and means for operating the machine, substantially as described.

50 In testimony whereof I affix my signature in presence of two witnesses.

ANTON AU.

Witnesses:

JOHN HAGMANN,
FRED RICHARD.