

March 29, 1938.

L. E. BARTON

2,112,687

REMOTE CONTROL APPARATUS

Filed Feb. 28, 1934

3 Sheets—Sheet 1

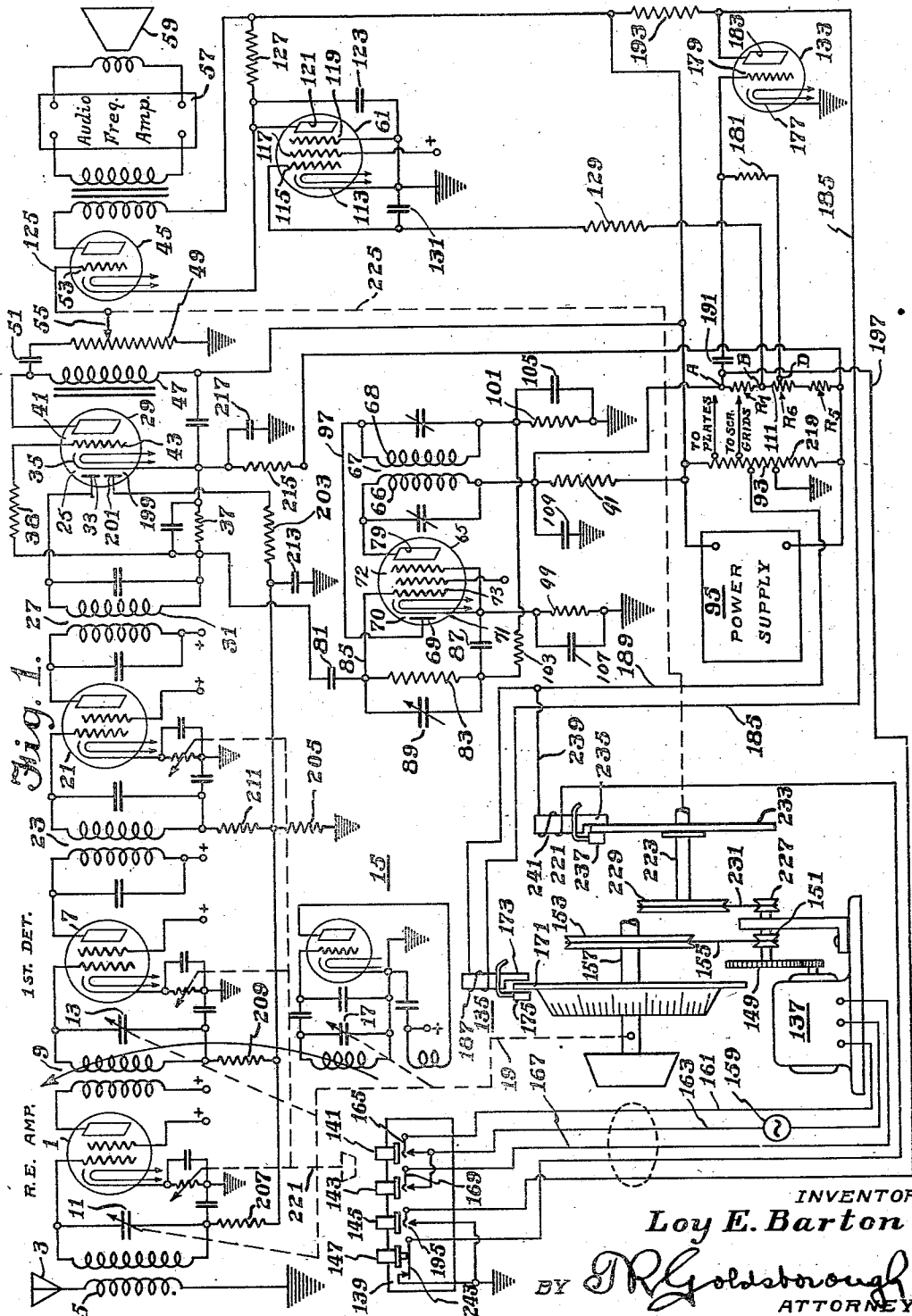

INVENTOR
Loy E. Barton

BY *R. Goldstoung*
ATTORNEY

March 29, 1938.

L. E. BARTON

2,112,687

REMOTE CONTROL APPARATUS

Filed Feb. 28, 1934

3 Sheets-Sheet 2

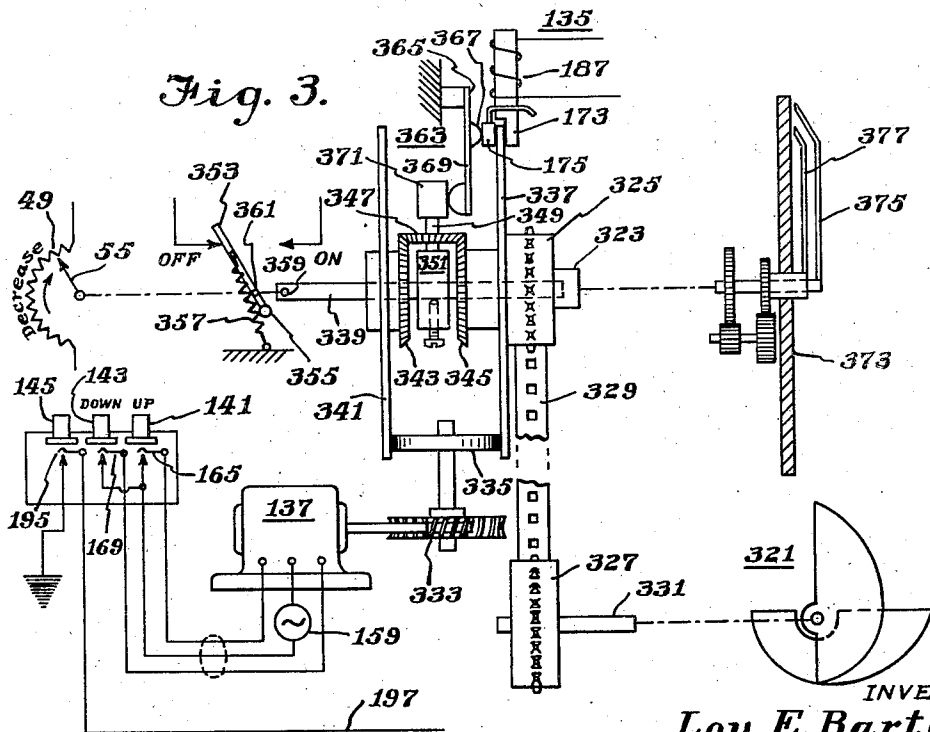
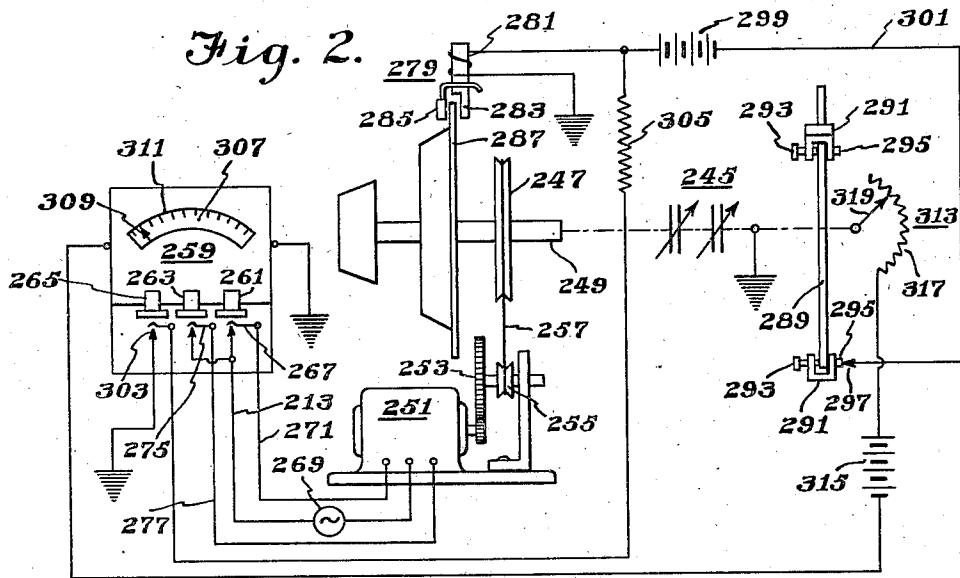

INVENTOR:

Loy E. Barton

BY *J. R. Goldborough*
ATTORNEY

March 29, 1938.

L. E. BARTON

2,112,687

REMOTE CONTROL APPARATUS

Filed Feb. 28, 1934

3 Sheets-Sheet 3

Fig. 4.

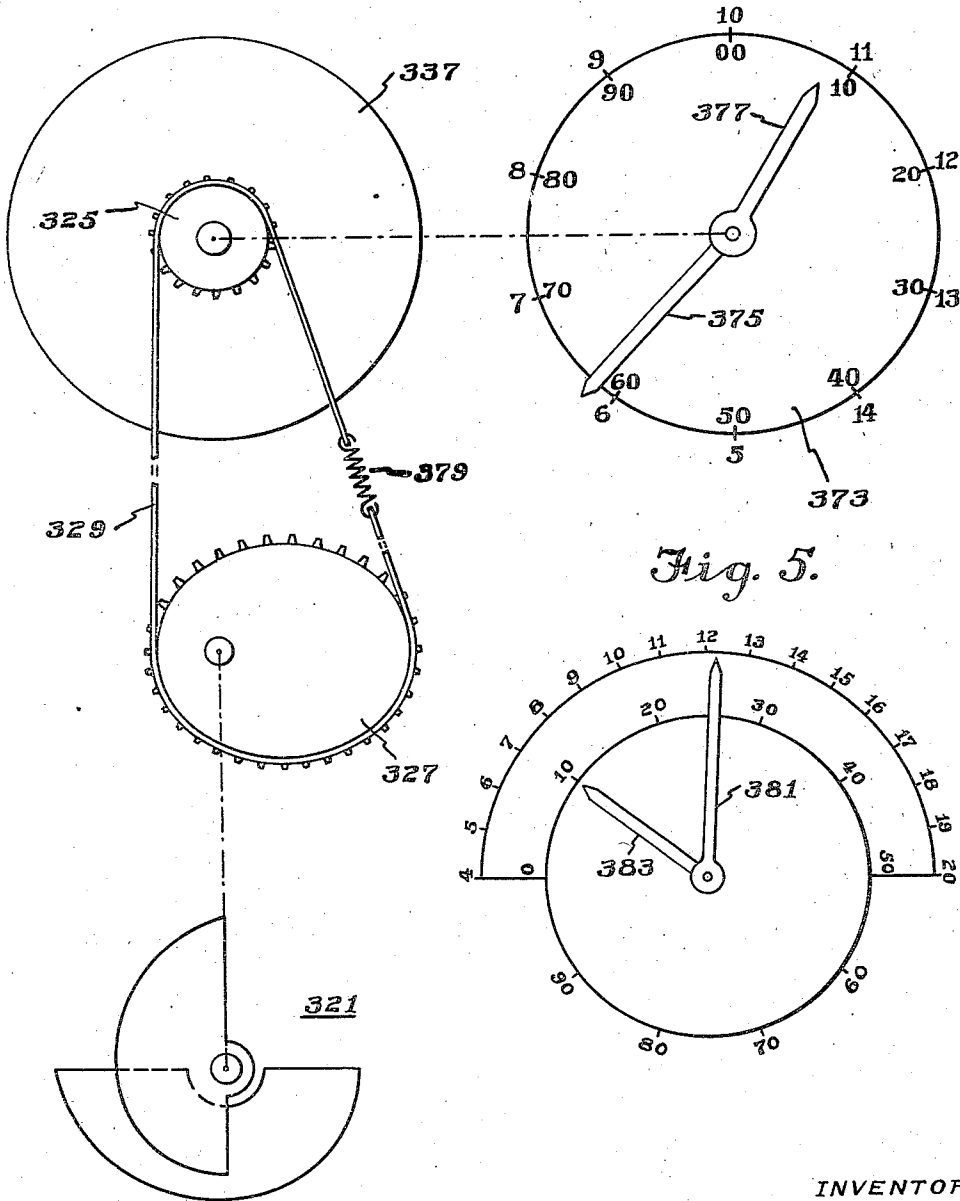
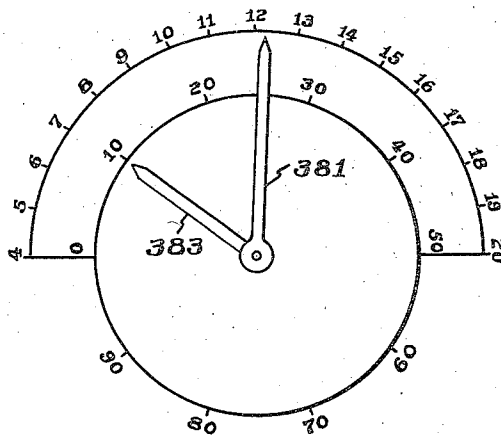

Fig. 5.



INVENTOR:
Loy E. Barton
BY *J. R. Goldborough*
ATTORNEY

UNITED STATES PATENT OFFICE

2,112,687

REMOTE CONTROL APPARATUS

Loy E. Barton, Collingswood, N. J., assignor to
Radio Corporation of America, a corporation of
Delaware

Application February 28, 1934, Serial No. 713,330

8 Claims. (Cl. 250—20)

My invention relates to remote control apparatus and particularly to remote control systems for radio receivers.

One object of my invention is to provide an improved remote control system by means of which a radio receiver may be tuned to receive any desired incoming signal.

A further object of my invention is to provide an improved remote control system which may be adjusted to tune the receiver to a predetermined number of transmitting stations.

A further object of my invention is to provide an improved remote control system having a small number of control buttons for tuning the receiver to a large number of stations.

A still further object of my invention is to provide an improved remote control system in which a tuning device and a volume control device may be actuated by a single motor.

A still further object of my invention is to provide an improved tuning dial mechanism for use with my remote control system.

In a preferred embodiment of my invention, I provide a motor which is coupled to the tuning condensers of a radio receiver through a friction drive and I further provide the tuning condensers with a magnetic brake for locking them in any desired position. The tuning condenser may be rotated in either direction by means of two push buttons located at a remote control point.

The brake is actuated in response to the tuning condensers reaching a position such that a radio station is tuned in, whereby they are immediately locked in the correct tuning position and the friction drive slips until the supply circuit to the motor is opened by releasing the push button in use at the remote control point. Preferably, the brake is actuated in response to the reception of a carrier wave having a predetermined amplitude.

By providing the receiver with a sensitivity control, it may be so adjusted that the remote control system will tune the receiver to a selected group of stations, such as local or nearby stations, having the strongest signals.

The volume control device for the receiver is driven through a second friction drive by the same motor that drives the tuning condensers. In one embodiment, a magnetic brake is provided for locking the volume control device in position while the receiver is being tuned to a station. After the station is tuned in and the tuning condensers locked in position by their magnetic brake, the volume control brake may be released and the volume increased or decreased by running the motor in one direction or the other. In another

embodiment, a single magnetic brake is employed and the volume control device is operated by locking in position one of two discs which are connected through gears for rotation in opposite directions.

Preferably, the receiver is provided with an improved tuning indicator consisting of two pointers mounted on a dial marked in kilocycles and resembling a clock face. One pointer is geared to rotate through ten scale divisions on a 360 degree scale while the other pointer rotates through one of its scale divisions. The relative position of the two pointers indicates the station setting of the receiver. Obviously these pointers can be seen from a considerable distance, especially if the dial is illuminated, so that a person tuning the receiver from a remote point can tell what station the receiver is tuned to.

By mechanically connecting the dial pointers and the tuning condensers through a cam, the scale divisions of the dial may be evenly spaced throughout the tuning range of the receiver while employing tuning condensers of the straight-line capacity or modified straight-line frequency type.

Other objects, features and advantages of my invention will appear from the following description taken in connection with the accompanying drawings, in which

Figure 1 is a circuit diagram of one embodiment of my invention;

Figure 2 is a schematic diagram of a modified form of my invention;

Figure 3 is a schematic diagram of tuning apparatus which may be substituted for that shown in Figure 1 and which includes a side-view of my improved tuning dial;

Figure 4 is a front view on an enlarged scale of the dial and a portion of the tuning apparatus shown in Figure 3; and

Figure 5 is a view of a modified form of my improved tuning dial.

Referring to Figure 1, an embodiment of my invention is shown applied to a superheterodyne receiver which comprises a radio frequency amplifier 1 having an input circuit coupled to an antenna 3 through a radio frequency transformer 5. The output circuit of the amplifier 1 is coupled to a first detector 7 through a radio frequency transformer 9.

The secondary windings of the transformers 5 and 9 have variable tuning condensers 11 and 13, respectively, connected thereacross in the usual manner, for tuning the input circuits of the amplifier 1 and first detector 7 to the desired incoming signal.

An oscillator 15 is coupled to the first detector 7 for the purpose of heterodyning an incoming signal to a lower intermediate frequency signal. The frequency of the oscillator output may be varied by means of a variable tuning condenser 17.

The tuning condensers 11, 13, and 17 are preferably units of a gang condenser, and may be varied simultaneously through a common tuning control indicated by a dotted line 19.

The intermediate frequency output of the first detector is impressed upon the input circuit of an intermediate frequency amplifier 21 through an intermediate frequency transformer 23, the primary and secondary of which are tuned to make the transformer function as a band-pass filter having a pass range of sufficient width to pass the intermediate frequency carrier and at least one signal side band.

It will be understood, of course, that the tuned radio frequency circuits of the amplifier 1 and detector 7 are also tuned broadly enough to pass the carrier of the incoming radio signal and at least one of its side bands.

The output of the intermediate frequency amplifier 21 is fed to the second detector 25 through an intermediate frequency transformer 27 tuned in the same manner as the preceding transformer 23.

In the particular embodiment illustrated, the second detector 25 is a diode rectifier which is one unit of a double diode-triode vacuum tube 29.

One terminal of the secondary 31 of transformer 27 is connected to the detector diode plate 33, while the other terminal of the secondary 31 is connected to the cathode 35 through a resistor 37, the resistor being shunted by means of an intermediate frequency by-pass condenser 39.

The triode section 41 of the vacuum tube 29 functions as the first audio frequency amplifier. Its control grid 43 is connected to the plate end of the resistor 37, whereby any audio signal appearing across the resistor 37 is impressed across the input of the triode section and an amplified audio signal appears in the plate circuit thereof.

A resistor 38 reduces the intermediate frequency voltage that may otherwise get to the grid 43.

The amplified audio signal is impressed upon the input circuit of another audio frequency amplifier stage comprising an electric discharge device such as a vacuum tube 45. The signal is impressed upon said input circuit through a coupling system which, in the embodiment shown, includes an audio frequency choke coil 47 in the plate circuit of the triode section 41. The upper end of the choke coil 47 is coupled to a volume control resistor 49 through a coupling condenser 51, the lower end of the resistor being connected to ground. The potentiometer 49 may be tapped to obtain the usual compensation of audio frequency signals at various volume levels.

The control grid 53 of the amplifier 45 is connected to the volume control resistor 49 through a variable volume control tap 55.

The output of the amplifier 45 may be further amplified by any suitable audio frequency amplifier, generally indicated at 57, and supplied to a loudspeaker 59.

It will be noted that the input circuit of the audio frequency amplifier 45 includes an electric discharge device 61 which may be a vacuum tube of the pentode type. The cathode-anode circuit of the tube 61 is connected between the cathode 63 of tube 45 and ground to function as a self-biasing resistor which may be given a very high resistance to block the amplifier tube 45 when

tuning between stations. In other words, the tube 61 applies noise suppressor control to the audio frequency amplifier tube 45 by functioning as a self-biasing resistor. This feature of my invention is described and claimed in my Patent No. 2,028,859, Serial No. 699,641, filed November 25, 1933, for Radio receivers, assigned to the same assignee as this application, and issued January 28, 1936.

The noise suppressor control is obtained, in the preferred circuit, through a diode-pentode vacuum tube 65 which is coupled to a transformer 67 sharply tuned to the intermediate frequency. As will be explained hereinafter, the tube 65 also functions to control the remote control circuit for tuning the receiver.

The tube 65 comprises a diode section 70 consisting of a diode plate 69 and a cathode 71, and a pentode section 72 consisting of the cathode 71, a control grid 73, a screen grid 75, a suppressor grid 77, and an anode 79.

The input circuit of the pentode section 72 is coupled to the resistor 37 in any suitable manner for impressing the low intermediate frequency voltage drop of the resistor across the pentode amplifier input circuit. In the drawings, this coupling device is shown as a small coupling condenser 81, having a comparatively low impedance to signals at the intermediate frequency, but having an impedance to audio frequency signals sufficient to prevent appreciable audio signal being applied to the control grid 73.

A coupling resistor 83 is provided which is connected at one end to the control grid 73 through a conductor 85, and connected at the other end to the cathode 71 through an audio-frequency by-pass condenser 87. The coupling resistor 83 is shunted by a variable condenser 89 which may be adjusted for the purpose of controlling the input voltage to the pentode amplifier 72.

The plate circuit of the pentode section 72 includes the primary winding 66 of the transformer 67 and a resistor 91, the primary winding and the resistor being connected in series, and the lower end of the resistor being connected to a positive point on the voltage divider 93 of the power supply 95.

The secondary winding 68 of the transformer 67 is loosely coupled to the primary winding 66, and both the primary and the secondary are tuned so that the transformer is tuned very sharply to the intermediate frequency.

The amplified intermediate frequency output of the pentode section 72 is transferred through the sharply tuned transformer 67 and impressed upon the elements 69 and 71 of the diode rectifier through a conductor 97 which connects the diode plate 69 to one terminal of the secondary winding 68, and through a connection from the cathode 71 to the other terminal of the secondary 68, which may be traced from the cathode 71 through a self biasing resistor 99 to ground, through ground to the lower terminal of a resistor 101, (which may have a resistance of the order of one megohm), and through the resistor 101 to the said other terminal of the secondary 68.

The sole function of the diode rectifier 70 is to increase the negative bias on the control grid 73 of the pentode section upon reception of a radio signal. Since a flow of current through the diode rectifier 70 causes the upper end of the resistor 101 to become negative, the control grid 73 also becomes more negative because of its connection to the negative end of the resistor 101 through a high impedance resistor 103.

Obviously an audio frequency signal will appear in the circuit of rectifier 70 which should not be impressed upon the control grid 73 of the pentode section. This is prevented by the audio frequency by-pass condenser 87.

It will be noted that the self biasing resistor 99, the resistor 101, and the plate resistor 91 are shunted by the usual intermediate frequency by-pass condensers 107, 105, and 109, respectively.

It will be apparent from the foregoing description that as soon as an intermediate frequency signal is impressed upon the input circuit of the pentode amplifier 72, the control grid 73 of that amplifier will become more negative because of the current flow through the circuit of the diode 70.

It may be noted that the change in bias on the control grid 73 depends, to a certain extent, upon the voltage drop produced in the self-biasing resistor 99, since this voltage drop is in series with the voltage drop along the resistor of the diode circuit. That these voltage drops are in series will be made evident by tracing the direct current path of the pentode section input circuit. It may be traced from the control grid 73 through the resistor 83, the high impedance resistor 103, through the diode circuit resistor 101 to ground, through ground to the self-biasing resistor 99, and through the self-biasing resistor 99 to cathode 71.

When there is no incoming signal, the plate current of the pentode amplifier portion 72 is large, since the only negative bias on the control grid 73 is that due to the self-biasing resistor 99, and this negative bias is comparatively small. Consequently there is a large voltage drop in the plate resistor 91, whereby the upper end of the resistor 91 is at a fairly high negative potential with respect to the upper end of the voltage divider 93. Also, the gain of amplifier 72 is low because of the low voltage on its anode 79.

As soon as the receiver is tuned to an incoming carrier wave, amplifier 72 supplies signal energy to the diode 70, the voltage drop in the diode circuit resistor 101 increases the negative bias on the control grid 73, whereby the plate current of amplifier 72 decreases and the upper end of the plate resistor 91 becomes less negative and the voltage applied to anode 79 is increased. It is the potential at this end of the plate resistor 91 which is utilized for actuating both the noise suppressor and certain remote control apparatus, this point in the circuit being identified as point A on the drawings.

It should be noted that although the decrease in plate current tends to cause a reduction in the biasing voltage in the self-biasing resistor 99, the increased negative bias provided by the current flow through the diode circuit is much greater than any decrease in bias due to reduction in plate current.

The above described action of the diode-pentode circuit whereby the upper end of plate resistor 91 becomes less negative in response to reception of a radio signal is preferably made a "trigger" action by giving plate resistor 91 a proper resistance value. This "trigger" action depends upon the fact that the increase in gain caused by the increase in the plate voltage is greater than the decrease in gain caused by the increase in negative bias on the grid until a more or less definite bias is reached. In practice, a tube of the type known as RCA 2B7 has been found satisfactory for use as the tube 65.

A trigger amplifier employing a resistor in the

plate circuit of a pentode tube is described and claimed in my co-pending application Serial No. 704,510, filed December 29, 1933, and assigned to the same assignee as this application.

In order to provide the proper control voltages for the noise suppressor biasing tube 61 and for the magnetic brake of the remote control circuit, which is described hereinafter, a potentiometer 111 is connected between the upper end of the plate resistor 91 and the negative end of the voltage divider 93. This potentiometer consists of three resistor sections, R5, R6, and R7, the sections R5 and R7 having a high resistance value which may be of the order of one megohm, while the resistor section R6 preferably has a lower value of the order of 100,000 ohms.

Referring now more specifically to the biasing tube 61, it has a cathode 113, a control grid 115, a screen grid 117, a suppressor grid 119, and an anode 121.

The anode 121 is connected to the cathode 63 of the audio frequency amplifier 45, while the cathode 113 is connected to ground, and through ground to the lower end of the volume control resistor 49. An audio frequency by-pass condenser 123 (preferably having a capacity of from 4 to 8 microfarads) is connected between the cathode 113 and anode 121 for by-passing the audio frequency signal around the plate impedance of the tube 61. Thus it will be seen that the plate impedance of the tube 61 is connected in the cathode circuit of the audio frequency amplifier 45 to act as a self-biasing resistor, while the audio frequency signal appearing across the volume control resistor 49 is impressed upon the input circuit of the audio frequency amplifier 45 through the conductor 125 and through ground and the by-pass condenser 123.

The anode 121 of the tube 61 preferably is connected to a positive point on the voltage divider 93 through a resistor 127 which may have a value of from one-fourth to one megohm. This resistor serves to maintain a high anode to cathode voltage when the tube 45 is blocked because of any leakage current taken by tube 61. The effect of the use of resistor 127 in the circuit is to make the noise suppressor more rapid and positive in operation.

When there is no incoming signal, the plate impedance of the biasing tube 61 is maintained at a very high value by means of the control grid 115 which has a high negative potential sufficient to block the tube. This high negative grid potential is obtained by connecting the control grid 115 to the lower end of the resistor R7, preferably through a resistor 129, this end of resistor R7 being identified as point B. Resistor 129 may be given a value of approximately one-half megohm.

The negative voltage applied to the control grid 115 from the point B is not critical in value, approximately 20 volts on the grid, with no incoming signal, having been found satisfactory when employing an RCA 57 tube as the tube 61.

Point B is given the desired negative voltage with respect to ground, the above-mentioned 20 volts, for example, by the proper selection of the resistor values of the potentiometer 111. In order to understand the operation of the circuit more clearly, specific voltage values for the voltage divider 93, the plate resistor 91, and the potentiometer 111 will be given.

In one specific embodiment, the voltage divider 93 is connected to ground at such a point intermediate its ends that the lower end of the voltage divider is 150 volts negative with respect to 75

ground, while the upper end of the voltage divider is 250 volts positive with respect to ground. With no incoming signal, and a plate resistor 91 having a value of from 50,000 to 100,000 ohms, the plate current of the pentode produces a voltage drop in the plate resistor 91 of sufficient magnitude to make the upper end of the resistor 91 and potentiometer 111 (identified as point A) 25 to 50 volts positive with respect to ground. The point B is then approximately 20 volts negative with respect to ground, and the upper end of resistor R5 (identified as point C) is still more negative with respect to ground.

Thus, with no incoming signal, a constant biasing voltage is applied from the point B to the control grid 115 of the biasing tube 61, a by-pass condenser 131 being connected between the control grid 115 and the cathode 113 for preventing audio frequency voltages or other ripple voltages from being applied to the grid.

The biasing voltage applied to the control grid 115 when there is no signal input is sufficient to block the tube 61, thereby making its plate resistance so high that the audio frequency amplifier tube 45 is likewise blocked. The blocking potential applied to tube 45 may become as high as 80 volts, this being much higher than necessary to block a tube such as an RCA 56 which has been found satisfactory for use with the RCA 57.

When the receiver is tuned exactly to an incoming signal, an intermediate frequency voltage is impressed upon the input circuit of the pentode section 72, whereby the voltage drop in the plate resistor 91 is decreased in value, causing the point B to assume a value sufficiently less negative to unblock the biasing tube 61 and greatly lower its plate impedance. This causes a normal biasing voltage to be applied to the grid 53 and the audio frequency amplifier 45 is immediately changed to its normal condition for an amplifier.

It should be noted that in case the point B becomes positive with respect to ground, it will cause grid current to flow through the resistor 129 so that the grid 115 will be maintained at substantially zero bias.

As fully explained in my above-mentioned co-pending application, Serial No. 699,641, filed November 25, 1933, the characteristics of the pentode 61 are such that the plate impedance of the tube remains substantially constant within the range of voltage applied to the control grid during the time the amplifier 45 is effective. This range of voltages is determined by the adjustment of the "trigger" amplifier 65. In a preferred adjustment the potential of point B is changed instantly from approximately 20 volts negative to about 3 volts negative upon reception of a signal.

Further slight voltage changes may be caused by variations in the strength of an incoming signal but they will not cause changes in the impedance of tube 61. For example, if the tube 61 is an RCA 57, its plate impedance will remain substantially constant for control grid voltages ranging from about 4 volts negative to zero and, since the variation in plate voltage of tube 65 is much greater than is necessary for the control of grid 115, considerable variation in signal may take place without affecting the bias on tube 45.

The remote control circuit for tuning the receiver comprises a control tube 133, a magnetic brake 135, a motor 137 and a remote control unit 139 which includes a plurality of control buttons 141, 143, 145 and 147. The motor 137 is connected through gears 149 and through a friction drive, such as a belt drive comprising pulleys 151

and 153 and a belt 155, to a shaft 157 for rotating the tuning condensers.

The shaft 157, which is shown broken off at one end, ordinarily would be the rotor shaft of a gang condenser, in the drawings a rigid connection 5 between this shaft and the tuning condensers being indicated by the dotted line 19.

The motor 137, which is of the reversible type, may be connected to a power supply 159 through cable conductors 161 and 163 for operation in one 10 direction by depressing the control button 141 to close a switch 165, or it may be run in the opposite direction by depressing the control button 143 whereby a reversing motor winding is connected to the power supply 159 through cable conductors 163 and 167 and a switch 169. Thus, it will be seen that the tuning condensers may be rotated to tune the receiver either up or down the tuning range by depressing either the button 141 or the button 143.

In order to stop the tuning condensers at the instant the receiver is exactly tuned to an incoming signal, the tuning condenser shaft 157 has mounted thereon a disc segment 171 which is positioned between the core 173 and the shoe 175 25 of the magnetic brake 135. The particular magnetic brake illustrated as well as the use of a brake for automatic tuning is disclosed and claimed in my co-pending application, Serial No. 700,471, filed December 1, 1933, and assigned to the same assignee as this application. It should be understood, however, that any electrically operated brake may be employed.

The brake 135 is actuated to lock the tuning condensers in position in response to the reception 35 of a signal by means of the trigger amplifier circuit and the control tube 133.

The control tube 133 includes a cathode 177 which is connected to ground, a control grid 179 40 which is connected to a point D on the resistor R6 through a grid leak resistor 181 (which may have a resistance of the order of one megohm), and an anode 183 which is connected through a conductor 185, to the magnet coil 187 of the brake 135, and a conductor 189 to a positive point on 45 the voltage divider 93. The control grid 179 also may be connected to the point A through a condenser 191, which may have a value of approximately 0.1 microfarad, to increase the speed with which the tube 133 is caused to function when the 50 receiver is tuned to an incoming signal.

It will generally be desirable to have the tube 133 and the biasing tube 61 start drawing plate current at the same time. Therefore, the point on the potentiometer 111 to which the control 55 grid 179 should be connected depends upon the relative characteristics of the two vacuum tubes. If the tube 133 were the same type as the tube 61, the control grid 179 preferably would be connected to the same point as the control grid of 60 tube 61, that is, to the point B.

So long as no signal is being received, as when the receiver is tuned between stations, the point D applies a negative potential to the control grid 179 which is sufficient to block the tube 133 so 65 that there is no plate current flow through the brake winding 187, and the brake 135 is deenergized.

There is, however, a small flow of current through the magnet winding 187, which flows in 70 a direction opposite to the flow of plate current, for the purpose of removing residual magnetism from the brake after it is de-energized. This flow of current may be traced from the positive end of the voltage divider 93, through a resistor 75

193 (which may have a resistance of the order of 100,000 ohms) to the conductor 185, and through the magnet winding 187 and the conductor 189 to a positive point on the voltage divider 93.

Assuming that the brake 135 is not energized, the receiver is tuned by depressing either the tuning button 141 or 143 to cause a rotation of the tuning condensers and the brake disc or segment 171. The instant the tuning condensers reach a position where the receiver is tuned to the carrier wave of an incoming signal, the voltage applied to the control grid 179 of the brake control tube 133 is changed. This change in control grid voltage is sufficient to cause a flow of plate current through the magnet coil 187 of the brake 135 and the brake is instantly energized thereby clamping the brake disc 171 between the brake shoe 175 and the core 173 to lock the rotors of the tuning condensers in position.

It should be noted that the tuning condensers are locked in the correct position for tuning the receiver exactly to a desired signal regardless of any tendency the motor may have to "over-run". In other words, it is not necessary to release a tuning button at a certain time in order to stop the tuning condensers at the right place. This result is obtained by means of the friction drive between the motor 137 and the tuning condenser shaft 157, the friction drive being so adjusted that it slips as soon as the brake 135 is energized whereby further rotation of the motor has no effect upon the position of the tuning condensers.

In order to tune the receiver to a different station after the brake has been energized, it is necessary to depress the brake release button 145 on the remote control unit. When the brake release button 145 is depressed, a switch 195 is closed whereby the upper end of the potentiometer resistor R7 is connected to ground through a conductor 197 so that a high negative potential is put on the control grid 179 thereby blocking the control tube 133 and releasing the brake 135.

From the above description it will be apparent that the receiver is tuned by depressing either the tuning button 141 or the tuning button 143, depending upon whether the receiver is to be tuned up or down the tuning range, and by depressing the brake release button 145 momentarily. Although the brake release button is depressed for only an instant to release the brake, (providing the next incoming signal is to be received), the tuning button is held down until a station is tuned in.

In some cases it may be desirable to have the receiver so adjusted that the remote control circuit will cause the receiver to tune in only a limited number of stations. Such an adjustment may be made by means of the sensitivity control. If the receiver is adjusted to have low sensitivity the magnetic brake 135 will be operated only in response to the reception of strong signals.

In practice, it is found both difficult and expensive to provide a control circuit for the magnetic brake which is so sharp that the selectivity of the control circuit is itself sufficient to prevent the magnetic brake from being operated too soon if strong signals are impressed upon the control circuit. This will readily be understood since the brake is operated when the plate current of tube 65 reaches a predetermined value. If signals of varying strength are impressed upon the input circuit of tube 65, a very strong signal at a frequency on one side of the resonant curve for the transformer 67 might produce the same plate current flow as a weaker signal at the inter-

mediate frequency which is located at the middle or peak of the resonant curve.

It has been found that the magnetic brake 135 may be made to operate at the proper time when employing a control circuit having reasonably sharp selectivity if the strength of all signals applied to the control circuit is held substantially uniform. A convenient way of accomplishing this is to provide the receiver with an automatic volume control circuit or AVC circuit which is applied to the portion of the receiver preceding the point supplying voltage to the brake control circuit.

While various forms of automatic volume control may be utilized, the circuit illustrated in the drawings is simple and effective in operation. The AVC circuit includes one of the diode rectifiers 199 of the vacuum tube 29, this diode comprising the cathode 35 and a plate 201. The plate 201 is connected through a filter resistor 203 and a volume control resistor 205 to ground. The junction point of the resistors 203 and 205 is connected to the control grids of the tubes 1, 7 and 21 through resistors 207, 209, and 211, respectively. A filter condenser 213 is connected between the grid end of the filter resistor 203 and ground.

The cathode 35 is connected to the negative end of the voltage divider 93 through a cathode resistor 215. This resistor is by-passed by means of an audio frequency by-pass condenser 217.

The operation of the AVC circuit is as follows: Assuming that a strong signal is being received, there is then maximum flow of current through the second detector resistor 37 and the control grid 43 is at a rather high negative potential, whereby the plate current of the tube 29 is small and there is a small voltage drop in the cathode resistor 215. Therefore, a large part of the voltage across the lower section 219 of the voltage divider 93 is impressed upon the diode rectifier 199. This will be seen by noting that the grounded point of the voltage divider 93 is connected to the plate 201 of the diode rectifier 199 through ground and through the volume control resistor 205, this grounded point being positive with respect to the cathode 35. The voltage across the voltage divider section 219 is large compared with the voltage drop in the volume control resistor 215 under the conditions assumed, so that although the two voltages are in opposition, the greater part of the voltage across the voltage divider section 219 is applied to the rectifier 199.

This results in a comparatively large flow of current through the resistor 205, with the result that the voltage drop in resistor 205 maintains the control grids of the tubes 1, 7, and 21 highly negative with respect to their cathodes, whereby their gain is held at a low value.

If the strength of the received signal becomes less, the control grid 43 becomes less negative, the plate current and the voltage drop in the resistor 215 increase, and a lower voltage is impressed across the rectifier 199. As a result, the current flow through the volume control resistor 205 decreases and the control grids of the tubes 1, 7, and 21 become less negative, whereby the gain of the receiver is increased to bring up the signal strength.

From the above description it will be apparent that the output of the transformer 27 remains substantially constant in amplitude so that signals of uniform amplitude are applied to the brake control circuit whereby it will function uniformly regardless of the strength of incoming signals.

Thus, the tuning condensers will never be stopped by the brake before they have been rotated to the proper position. The above described automatic volume control circuit is described and claimed in my application Serial No. 640,946, filed November 5, 1932, and assigned to the same assignee as this application.

The manual volume control device 55 in the receiver may be controlled from the remote control unit by utilizing the motor 137 and a second magnetic brake 231. The arm 55 of the volume control potentiometer 49 is preferably rotatably mounted and connected to a shaft 223, as indicated by the dotted line 225. The shaft 223 is connected to the motor 137 through the gears 149 and through a second friction drive which comprises pulleys 227 and 229 and a belt 231. A brake disc 233 is fastened to the shaft 223 and positioned to extend between the core 235 and brake shoe 237 of the magnetic brake 221.

A flow of current is normally supplied from voltage divider 93 through the conductors 189 and 239 to the magnet winding 241 of the brake for locking the shaft 223, and therefore the potentiometer arm 55, in position. It will be evident that so long as the shaft 223 is locked in position, rotation of the motor 137 merely causes slippage of the belt 231. Therefore the receiver may be tuned to any desired station and the volume control device 55 will not be affected.

After the receiver is tuned to a station, however, and the tuning brake 135 is energized, the volume control device 55 may be operated by depressing the volume control button 147 whereby a switch 243 is opened to break the circuit through the winding 241 of the volume control brake 221. So long as the volume control button 147 is depressed, the volume control device 55 may be operated to either increase or decrease the volume by depressing either the tuning button 141 or the tuning button 143, since the belt 155 will slip and the belt 231 will be effective.

A switch may be provided in the volume control or on the volume control shaft to permit turning off the set at the minimum volume control position. To turn the set on it would only be necessary to depress the up button until the dial is illuminated after which the tubes should be allowed to heat before further tuning is attempted, from the remote point. This operation necessitates a separate alternating current power source 159 for the motor. An "on-off" switch of this type is described hereinafter in connection with Figure 3.

Referring to Figure 2 there is shown a remote control circuit which permits a radio receiver to be set up for the reception of certain predetermined stations. The tuning condensers which are indicated generally at 245 have a pulley 247 mounted upon their rotor shaft 249. A motor 251 of the reversible type is connected to the rotor shaft 249 through gears 253 and through a pulley 255 which is connected to the pulley 247 by means of a belt 257.

A remote control unit 259 is provided which has tuning buttons 261 and 263 and a brake release button 265 mounted thereon. The motor may be run in one direction by depressing the tuning button 261 whereby a switch 267 is closed to connect a source of power 269 to one of the motor windings through cable conductors 271 and 273. The motor 251 may be run in the opposite direction by pressing the tuning button 263 whereby a switch 275 is closed to connect the reversing motor winding to the source of

power 269 through cable conductors 273 and 277.

A magnetic brake 279 is provided for locking the tuning condensers 245 in place at any predetermined position. This brake includes a magnetic winding 281, a magnetic core 283, and a brake shoe 285. A sector 287 of a disc, preferably of magnetic material, is mounted upon the condenser shaft 249 in such a position that it extends between the core 283 and the brake shoe 285 whereby actuation of the brake 279 will clamp it securely in position.

The apparatus for actuating the brake 279 when the receiver is tuned to a desired station comprises a disc 289 mounted upon the condenser shaft 249, or otherwise mounted for fixed rotation therewith, and a plurality of contact devices 291 clamped to the periphery of the disc 289. Each contact device consists of a U-shaped clamp member having a set screw 293 therein and a contact member 295 which preferably has a knife edge. By loosening the set screw 293, the contact device 291 may be moved to any desired position on the disc 289 for tuning in a certain station and again clamped in position.

A contact point 297 is fixedly mounted in such position that when a contact member 295 is rotated to a position adjacent thereto, contact is made to complete a circuit through the magnet winding 281 to energize the brake 279. This brake energizing circuit may be traced from the lower terminal of the brake winding 281, which is grounded, through the winding 281 and through a battery 299, the conductor 301, the contact member 297, and the disc 289, back to ground through the rotor shaft of the condensers 245.

From the above description it will be understood that the receiver may be tuned in one direction by depressing the tuning button 261, assuming that the brake 279 is de-energized. This will cause the tuning condensers 245 to be rotated until a contact member 295 comes into contact with the contact point 297, at which instant the brake 279 is energized to clamp the tuning condensers 245 in position. Further rotation of the motor 251 will have no effect upon the tuning of the receiver since the belt 257 will slip.

To tune the receiver to a different station either the tuning button 261 or the tuning button 263 is depressed, depending upon whether it is desired to tune the receiver up or down the tuning scale, and the brake release button 265 is depressed momentarily. By depressing the brake release button 265 a switch 303 is closed to connect a resistor 305 across the brake winding 281 whereby the winding is substantially short-circuited and the brake is de-energized. It will be seen that as soon as the brake 279 is released, the condensers 245 and the disc 289 are rotated and the brake circuit is broken at the contact member 295 and the contact point 297. Therefore, if the brake release button 265 has been permitted to move back to its upper position, the brake 279 will again be energized as soon as the contact point 297 comes into contact with the next contact member 295.

Since it may be desirable to operate the receiver at a remote point located where the tuning dial of the main receiver unit cannot be seen, it is desirable to have an indicator on the remote control unit 259 to indicate the tuning position of the receiver. Such a device is illustrated consisting of a milliammeter 307 having a pointer 309 cooperating with a scale 311 calibrated in kilocycles, and a variable resistance device 313 and a bat-

tery 315 for actuating the milliammeter 307. The resistance device 313 consists of a resistor winding 317 arranged in the form of a semi-circle and a contact arm 319 cooperating therewith and fastened to the condenser shaft 249. The resistor winding 317 is connected in series with the milliammeter 307 and the battery 315 so that the current flowing through the milliammeter, and consequently the position of the pointer 309, depends upon the position of the tuning condensers 245.

Referring to Figure 3 there is shown remote control apparatus which may be substituted for the corresponding remote control apparatus shown in Figure 1. In the two figures like parts are indicated by the same reference numbers. As will appear from the following description the apparatus shown in Figure 3 permits remote control of both the tuning and the volume while utilizing only one magnetic brake and only three control buttons. In this case the tuning condensers indicated at 321 are driven from a short shaft 323 through sprocket wheels 325 and 327 and a perforated metal belt 329, the sprocket wheel 327 being mounted off center on the tuning condenser shaft 331, as shown in Figure 4, to act as a cam for purposes which will be explained hereinafter. The shaft 323 is coupled to the motor 137 through a worm gear 333, and a friction driven device including friction wheels 335 and 337.

A volume control shaft 339 is provided upon which the friction disc 337 and a similar friction disc 341 are rotatably mounted. When the friction disc 337 is held in a fixed position by the brake 187, the shaft 339 may be driven through the friction discs 335 and 341 and bevel gears 343, 345, and 347. Gears 343 and 345 are mounted to rotate with the friction discs 341 and 337, respectively. The bevel gear 347, which is positioned between and meshes with the bevel gears 343 and 345, is rotatably mounted upon a short shaft 349 extending from a collar 351 locked in position on the shaft 339 by means of a set screw.

It will be seen that if the two friction discs 341 and 337 are free to rotate, operation of the motor 137 will cause them to rotate in opposite directions at the same speed whereby the center bevel gear 347 will rotate without causing rotation of the shaft 339. On the other hand, if the friction disc 337 is locked in position there will be slippage between the friction discs 335 and 337, and the friction disc 341 will be the only one which will rotate whereby the shaft 339 will be rotated through the bevel gears.

The magnetic brake 135 is mounted adjacent the friction disc 337 to lock it in position in response to the reception of an incoming signal. Therefore, if either the tuning button 141 or 143 is depressed, assuming that the brake is not clamping the friction disc 337 in position, the two friction discs 337 and 341 will be rotated in opposite directions, the shaft 339 will remain stationary while the tuning condensers 321 will be driven through the metal belt 329. As soon as the tuning condensers 321 reach a position such that a signal is tuned in, the brake 135 is automatically energized to prevent further movement of the tuning condensers (as explained in connection with Figure 1) and there is slippage between the friction discs 335 and 337 so long as the tuning button is held down. Therefore, as soon as a station is tuned in, the tuning button should be released immediately, unless it is desired to

change the volume as will be understood from the following description.

Remote control of the volume is obtained by connecting the movable arm 55 of the volume control device to the shaft 339. From the foregoing description it will be understood that, when the friction disc 337 is locked in position, the volume may be either increased or decreased by depressing the proper tuning button. Thus, after a station has been tuned in and the brake 135 energized, operation of either one of the tuning buttons will cause a change in the volume.

In order to turn the radio receiver on or off by actuating the tuning buttons, a switch 353 is mounted adjacent to the volume control shaft 339 for actuation thereby. The switch is of a conventional type pivoted at the point 355 and provided with a spring 357 for moving the switch either to the "on" or "off" position when the switch arm is moved to one side of its center position. A pin 359 on the volume control shaft cooperates with any suitable device such as a pin 361 on the switch arm for connecting the switch arm over to its "on" or "off" position when the volume control shaft is rotated to predetermined positions.

In Figure 3 the apparatus is illustrated in the "off" position of the receiver. It will be noted that the volume control device 55 is in its low volume position. It will also be noted that the friction disc 337 is locked in position by means of a spring arm and cam device 363 which is provided for reasons that will be apparent from the description hereinafter. A spring arm 365 is mounted opposite the brake 135 and provided with a projecting member 367 which is positioned to engage the brake shoe 175. The lower end of the spring arm 365 is provided with a cam member 369 positioned to cooperate with a pin 371 mounted upon one end of the bevel gear shaft 349. In the "off" position of the receiver, therefore, the pin 371 forces the projecting member 367 against the brake shoe and locks the friction disc 337 in position.

Assume now that it is desired to turn the receiving set on. The tuning button marked "Up" is depressed and the motor rotates the friction disc 341 in such a direction as to move the pin 371 off the cam 369, the friction disc 337 being locked up to this point. Before the pin 371 moves off the cam member 369, however, the volume control shaft 339 has been rotated sufficiently to kick the switch arm 353 over to the "on" position. The operator of the receiver should now wait a few seconds until the vacuum tubes of the receiver have warmed up sufficiently to permit operation of the receiver.

At the end of the warming up period the receiver may be tuned either up or down the tuning scale by depressing the proper tuning button since the spring arm 365 has released the brake shoe 175 and friction discs 337 and 341 are free to rotate. As soon as the receiver is tuned to an incoming signal, the brake 135 is automatically energized and the friction disc 337 is again locked in position. The volume may now be increased by depressing the tuning button marked "Up" or decreased by depressing the tuning button marked "Down".

To tune the receiver to another station, both a tuning button and the brake release button 145 are depressed, the brake release button being depressed only momentarily if the next incoming signal is to be received. If it is desired to tune the receiver through a number of stations, the

brake release button is held down until the receiver is tuned close to the desired station, at which time it is released.

To turn the power off the receiver, the "Down" tuning button is depressed. Ordinarily an incoming signal will be holding the brake 135 energized so that the friction disc 337 will not be free to move, and the volume control shaft 339 will be rotated to such a position that it will kick the switch arm 353 over to the "off" position. It will be noted that in this position the spring arm 365 is again forced against the brake shoe 175 to lock the friction disc 337. In the event that it is desired to turn off the receiver when there is no incoming signal, it is merely necessary to hold down the tuning button until the tuning condensers have been rotated to their limiting position, at which position further rotation of the friction disc 337 is prevented so that the other friction disc 341 will drive the volume control shaft.

While a conventional tuning dial may be employed with my receiver, the type of dial illustrated in Figures 3 and 4 is preferred. This tuning dial comprises a dial face 373 having two scales marked thereon (as shown in Figure 4), the inner scale being divided into ten equal units and the outer scale being divided into a number of units determined by the tuning range to be covered by the receiver. In Figure 4, both scales are shown divided into ten units.

Two pointers are provided, one pointer 375 being connected directly to the sprocket wheel shaft 323 and the other pointer 377 being geared to the sprocket wheel shaft 323, the gear ratio being such that the pointer 377 cooperating with the inner scale makes one complete rotation while the pointer 375 cooperating with the outer scale moves through one scale division. In the particular embodiment illustrated in Figure 4, the pointer 377 which cooperates with the inner scale makes ten rotations while the pointer 375 makes one rotation.

The dial shown in Figure 4 is calibrated for use with a receiver having a tuning range of from 550 kilocycles to 1500 kilocycles. The numerals on the outer scale represent the first numerals of the kilocycle reading, while the numerals on the inner scale represent the last two numerals of the kilocycle reading. Thus with the pointers in the position shown the dial reading is approximately 608 kilocycles.

It will be evident that when employing this type of dial the scale divisions should be evenly spaced apart throughout the tuning range of the receiver. Obviously the dial divisions would be so spaced if straight line frequency tuning condensers were employed, the tuning condensers being connected to the sprocket wheel through a simple sprocket wheel and belt mechanism having a 2:1 ratio. In practice, the use of straight line frequency condensers has been found undesirable for various reasons, one reason being that the straight line frequency condenser occupies too much space.

In accordance with one feature of my invention I utilize either straight line capacity condensers, or preferably, the so-called modified straight line frequency condensers, and shape the sprocket wheel 327 to form a cam. The cam 327 is so shaped that, at the high frequency end of the tuning range where the stations are normally crowded together on the tuning dial, the tuning condensers are rotated only a slight amount during a comparatively great rotation of the sprocket wheel 325 and the tuning dial

pointers. Since with this cam arrangement the length of belt required between the sprocket wheel 325 and the cam 327 varies with the position of the cam, the ends of the belt 329 are connected by means of a spring 379.

Referring to Figure 5, a modified tuning dial arrangement is illustrated in which the main pointer 381 rotates through only 180°. The small pointer 383, however, rotates through 360° and, as in the case of the dial shown in Figure 4, it rotates through ten dial divisions while the main pointer rotates through a single dial division. The dial illustrated is designed for use with a receiver having a tuning range from 400 kilocycles to 2000 kilocycles. The dial is read the same as the dial previously described, the reading for the dial with the pointers in the positions shown being 1210 kilocycles.

Various other modifications may be made in my invention without departing from the spirit and scope thereof and I desire therefore that only such limitations shall be placed thereon as are necessitated by the prior art and set forth in the appended claims.

I claim as my invention:

1. In a remote control system for a radio receiver having a tuning device and a volume control device, a motor, a friction drive connecting said motor and said tuning device, a second friction drive connecting said motor and said volume control device, a brake for said tuning device, a brake for said volume control device, means including a switch at a point remote from said receiver for starting said motor, and means including a switch at said remote point for operating said second brake.

2. Radio receiver apparatus comprising a tuning unit, a volume control unit, two coaxially and rotatably mounted drive members, said tuning unit being connected to one of said drive members, means for rotating said drive members in opposite directions through a friction drive, a volume control shaft extending through the axis of one of said drive members and connected to said volume control unit, a gear shaft rigidly secured to said volume control shaft, and at right angles thereto, a gear wheel rotatably mounted upon said gear shaft, a second gear wheel rigidly secured to one of said drive members and engaging one side of said first gear wheel, a third gear wheel rigidly secured to the other of said drive members and engaging the opposite side of said first gear wheel, and a brake for engaging the drive member to which the tuning unit is connected.

3. In a remote control system for a radio receiver having a tuning device, a motor, a tuning dial having equally spaced frequency markings thereon, a driving shaft, means for coupling said dial to said shaft, means for coupling said motor to said shaft, means for coupling said tuning device to said shaft, said last means including a driving wheel having teeth thereon, a driven wheel having teeth thereon, one of said wheels being shaped to act as a cam, and a belt connecting said two wheels, the ends of said belt being connected by means of a connector which is flexible in a longitudinal direction to permit variations in the length of the belt, means for applying power to said motor in response to the actuation of a tuning control unit whereby said tuning device is moved to tune the receiver, and means including a brake for stopping the movement of said driving shaft in response to the receiver being tuned to an incoming signal.

4. Radio apparatus comprising a main receiver unit having a tuning unit therein, a motor, a friction drive for coupling said motor and said tuning unit, a remote-control unit connected to said main unit and including two switches, means for running said motor in one direction in response to closing one of said switches, means for running said motor in the opposite direction in response to closing the other of said switches, a brake for said tuning unit, means independent of said first named means for actuating said brake, means provided in connection with said brake actuating means for controlling the latter in response to signal waves having a predetermined strength, and means for controlling the signal level at which said last named means responds.

5. Radio apparatus comprising a main receiver unit having a tuning unit therein, a motor, a friction drive for coupling said motor and said tuning unit, a remote-control unit connected to said main unit and including two switches, means for running said motor in one direction in response to closing one of said switches, means for running said motor in the opposite direction in response to closing the other of said switches, a brake for said tuning unit, means independent of said first named means for actuating said brake, and means provided in connection with said brake actuating means for controlling the latter in response to received signal waves of predetermined strength.

6. Radio apparatus comprising a main receiver unit having a tuning unit therein, a motor, a friction drive for coupling said motor and said tuning unit, a remote-control unit connected to said main unit and including two switches, means for

running said motor in one direction in response to closing one of said switches, means for running said motor in the opposite direction in response to closing the other of said switches, a brake for said tuning unit, means independent of said first named means for actuating said brake, in response to received signal of predetermined strength, a third switch at said remote-control unit, and means for releasing said brake in response to the actuation of said third switch.

7. In a remote control system for a radio receiver having a tuning device, a motor, a friction drive connecting said motor and said tuning device, a brake for said tuning device, means including a remote control unit having a pair of switches, means for running said motor in one direction in response to closing one of said switches, means for running said motor in the opposite direction in response to closing the other of said switches, means for actuating said brake in response to said receiver being tuned to an incoming signal, and means for making said last means effective only when the strength of said incoming signal is above a predetermined value.

8. In a remote control system for a radio receiver having a tuning device and a volume control device, a motor drive means connecting said motor and said tuning device, a second drive means connecting said motor and said volume control device, means for locking said tuning device and volume control device in positions of adjustment, means including a switch at a point remote from said receiver for starting said motor, and means including a switch at said remote point for operating said volume control means.

LOY E. BARTON.