

H. H. Haskett,

Watchmakers Lathe.

No. 100,891.

Patented Mar. 15, 1870.

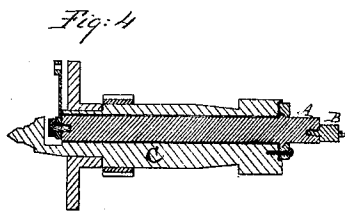
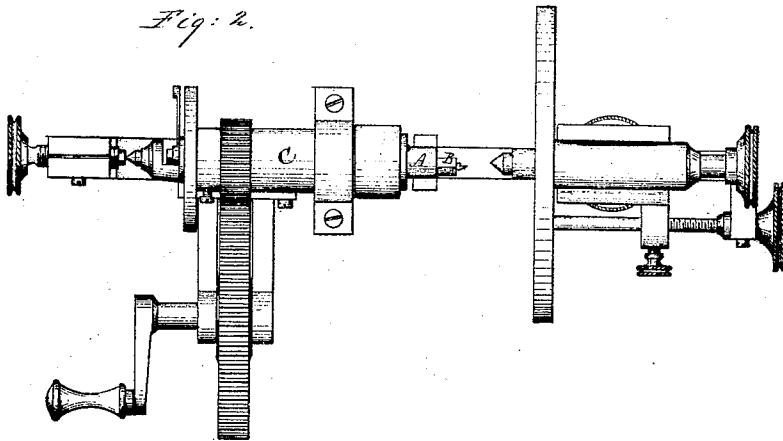
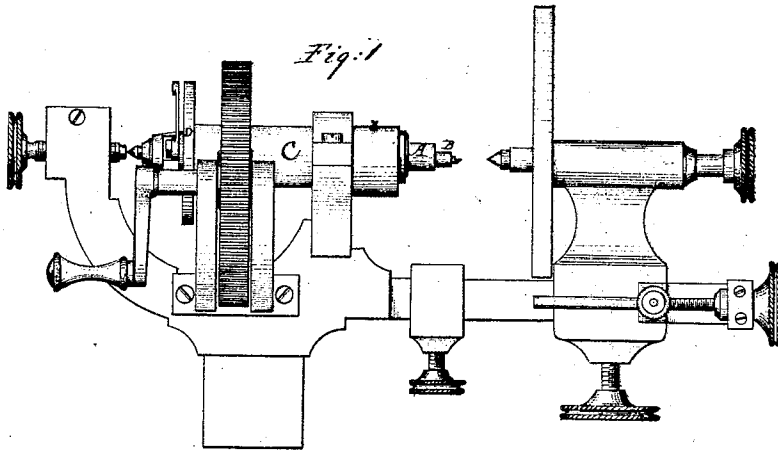

Fig. 3

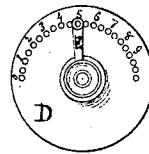

Fig. 5



Witnesses

*J. H. Phillips
S. C. Hestekrup.*

Inventor

*H. H. Haskett
By Jas. W. Somers
Att. in fact.*

United States Patent Office.

H. H. HESKETT, OF McLEAN COUNTY, ILLINOIS.

Letters Patent No. 100,891, dated March 15, 1870.

IMPROVED LATHE FOR SETTING JEWELS IN TIME-PIECES.

The Schedule referred to in these Letters Patent and making part of the same

To whom it may concern:

Be it known that I, H. H. HESKETT, of the county of McLean, and State of Illinois, have invented a new and useful Improvement in Lathes for Setting Jewels in Time-Pieces; and I do hereby declare that the following is a full, clear, and exact description of the construction and operation of the same, reference being had to the annexed drawings making a part of this specification, in which—

Figure 1 is a longitudinal elevation of a lathe with my improvement;

Figure 2, a plan view of the same;

Figure 3, the index-plate, with a combined pointer and lever for indicating the size of the jewel-sash and holding the bit in place;

Figure 4, a longitudinal section of the arbor and bit stock; and

Figure 5 showing the arrangement of the double eccentric, which constitutes the main feature of my invention.

The description of my invention is substantially as follows, to wit:

An arbor, C, a section of which is shown in fig. 4, is adjusted to an ordinary turning-lathe frame, as represented in figs. 1 and 2.

Said arbor has a hole extending longitudinally through it, eccentric to its axis, into which is inserted the bit-

stock A, and said bit-stock is provided also with a longitudinal hole, eccentric to its axis, into which is inserted the bit-holder B, in which the cutting-tool is held.

On the reverse or outer end of the arbor is attached the index-plate D, which is perforated with small holes or notches on one-half thereof, and near the circumference, for the purpose of indicating the size of the sash for the jewel, and also to secure the bit by means of a lever and pointer, E, attached to the bit-stock.

The holes or notches are numbered, to indicate the size of the jewel to be set.

The plate is centered and held in the usual manner in setting jewels, and for which no claim is made.

Having described my invention,

What I claim as new, and desire to secure by Letters Patent, is—

The combination of the arbor C, index-plate D, and lever E with bit-stock A and holder B, placed eccentrically relatively toward each other and to the said arbor, as described, and operating substantially in the manner and for the purpose set forth.

H. H. HESKETT.

Witnesses:

W. H. SOMERS,
JAMES H. LINCOLN.