

(19)



Europäisches Patentamt  
European Patent Office  
Office européen des brevets



(11)

**EP 0 867 685 A2**

(12)

**EUROPEAN PATENT APPLICATION**

(43) Date of publication:  
**30.09.1998 Bulletin 1998/40**

(51) Int Cl.6: **F41A 17/04**

(21) Application number: **98110305.4**

(22) Date of filing: **23.01.1992**

(84) Designated Contracting States:  
**AT BE CH DE DK ES FR GB GR IT LI LU MC NL SE**

(72) Inventor: **Brooks, Frank**  
**Jupiter, FL 33458 (US)**

(30) Priority: **24.01.1991 US 645565**  
**24.01.1991 US 645566**

(74) Representative: **Patentanwälte**  
**Ruff, Beier, Schöndorf und Mütschele**  
**Willy-Brandt-Strasse 28**  
**70173 Stuttgart (DE)**

(62) Document number(s) of the earlier application(s) in  
accordance with Art. 76 EPC:  
**92905282.7 / 0 568 634**

Remarks:

This application was filed on 05 06 98 as a divisional  
application to the application mentioned under INID  
code 62.

(71) Applicants:  
• **SAF T LOK CORPORATION**  
**West Palm Beach, FL 33407 (US)**  
• **BROOKS, Frank**  
**Jupiter, FL 33458 (US)**

(54) **Gun lock assembly**

(57) These and other objects are accomplished by  
a gun lock assembly having an engagement portion with  
a locked position in which a portion of the firing mecha-  
nism is operatively engaged to prevent firing of the fire-  
arm, and an unlocked position in which operation of the  
firearm is permitted. The lock preferably comprises a

lock housing with structure for attaching the lock hous-  
ing to the firearm. A combination lock is preferably pro-  
vided with structure for altering the combination. A  
mounting plate for the lock is also described. Alternative  
lock constructions suitable with different types of fire-  
arms are also disclosed.

**EP 0 867 685 A2**

## Description

### Cross-reference to Related Applications

This application is a continuation-in-part application of Applicant's co-pending United States Patent Application Serial No. 645,565, filed January 24, 1991, and United States Patent Application Serial No. 645,566, filed January 24, 1991.

### Technical Field

This invention relates generally to firearm locks, and more particularly to firearm locks which are provided so as to be substantially integral with the firearm.

### Background Art

There is a continuing need to provide locks for firearms which will effectively prevent operation of the firearm by unauthorized users, but which are readily manipulated by authorized users to permit deactivation of the lock and operation of the firearm in an emergency. It is desirable that such a lock be easily installed and non-intrusive to the integrity of the firearm, such that continued reliability of the firearm is insured after installation of the lock. It is also desirable that such a lock be entirely integral with the firearm, such that the lock or a key for the lock cannot be misplaced or lost.

There have been many attempts to devise locks for firearms which will prevent unauthorized use of the firearm. These locks often are not integral with the firearm, and accordingly, must be removed in order to render the firearm operable, and can thereby be lost or misplaced. Prior locks for firearms which have been made to be integral with the firearm require extensive modification to the firearm, and thus can affect the reliability of the firearm and require time and expense for proper installation. These firearm locks are sometimes difficult to manipulate, and therefore can be dangerous in an emergency where quick operation of the firearm is necessary.

### Disclosure of the Invention

It is an object of the invention to prevent the operation of firearms by unauthorized users.

It is another object of the invention to provide a lock for firearms which is easily installed.

It is yet another object of the invention to provide a lock for firearms which is integral with the firearm and will preclude the possibility that the lock will be lost or misplaced.

It is another object of the invention to provide a lock for firearms which will not affect the reliability of the firearm.

It is still another object of the invention to provide a lock for firearms which can be readily deactivated to per-

mit quick operation of the firearm in an emergency.

It is yet another object of the invention to provide a lock for firearms which can be installed in the firearm without extensive modification to the firearm.

It is still another object of the invention to provide a lock assembly in which the combination required to open the lock can be readily changed by an authorized user.

These and other objects are accomplished by a gun lock assembly having an engagement portion with a locked position in which a portion of the firing mechanism is operatively engaged to prevent firing of the firearm, and an unlocked position in which operation of the firearm is permitted. The lock preferably comprises a lock housing with structure for attaching the lock housing to the firearm.

A mounting plate is preferably provided which can be attached to the frame of the firearm. This can be accomplished in pre-existing firearms by removing the existing handle grip of the firearm and attaching the mounting plate to the firearm with fastening structure. The mounting plate has engagement structure for engaging a portion of the lock when the lock is in the locked position, and for disengaging the portion when the lock is in the unlocked position. The lock housing preferably encloses at least part of the fastening structure and the engagement structure, such that the mounting plate and lock cannot be removed from the firearm when the lock is in the locked position. The design of the mounting plate can be readily adapted to fit most firearms.

The lock is preferably a combination lock having a plurality of push buttons accessible from the exterior of the housing for entering an appropriate combination. A plurality of elongated ratchet members having ratchet teeth can be slidably disposed within the housing. A ratchet return biasing member is provided to return the ratchet members to an initial position. A ratchet pawl is connected to the push buttons and is operable to move the ratchet members against the biasing when the push buttons are depressed. Additional biasing is provided to return the push buttons and ratchet pawl to the starting position. A detent is associated with each ratchet member to prevent the return of the ratchet member to the initial position under the influence of the ratchet return biasing.

A key-way carrier is associated with each ratchet member and is moveable with each ratchet member. A lock slide is positioned adjacent to the ratchet members and includes a plurality of keys. The keys are slidable into the key-ways when the ratchet members and key-way carriers have been moved an appropriate number of times by operation of the push buttons to align each key-way with the respective key.

The engagement portion of the lock is fixed to the lock slide, such that the engagement portion can be moved to the unlocked position only when the key-ways are aligned with the keys of the lock slide according to the appropriate combination. The lock slide and the en-

gement portion can then be moved to the unlocked position.

A reset is provided to initialize the ratchet members for locking the lock and to provide a consistent starting point for re-entering the combination. Reset arms are disposed adjacent to the ratchet pawls and detents to move the pawls and detents out of engagement with the ratchet members to release the ratchet members when the reset button is pushed. This will permit the ratchet members to return to the initial position under the influence of the ratchet return spring.

The position of the key-way carriers with respect to the associated ratchet members is preferably adjustable so as to provide for changing the combination of the lock. In a preferred embodiment, the key-way carrier can be inverted so as to present an alternate side of the key-way carrier to the keys of the lock slide. The alternate side has a key-way in a different position, such that the number of operations of the push button necessary to align that key-way with the respective key on the lock slide is changed.

Structure is provided for preventing the operation of the reset button when the lock slide is not fully in the locked position. Structure is also provided for urging the lock slide and keys out of engagement with the key-way carriers to permit substantially free travel of the ratchet members to the initial position during the reset function.

The lock is particularly useful for engagement of any existing external safety mechanism of the firearm. In the locked position, the engagement portion of the lock prevents movement of the safety to the "unsafe" position, so as to prevent operation of the firearm. In the unlocked position, the engagement portion is moved out of operative engagement with the existing external safety, so as to permit movement of the safety to the "unsafe" position and operation of the firearm.

An embodiment of the invention is useful for locking revolvers, which typically do not have an external safety mechanism. A lever or other member is provided in association with the lock. The lever or other member has a locked position blocking the stirrup or another portion of the firing mechanism of the revolver to prevent operation of the revolver, and an unlocked position permitting operation of the revolver. The lever or other member is moved to the blocking position by movement of the lock to the locked position, and can be moved from the blocking position with movement of the lock to the unlocked position. The revolver lock of the invention is also useful with alternative lock constructions.

A grip lock assembly for firearms includes a lock having a locked position preventing operation of the firearm, and an unlocked position permitting operation of the firearm. A portion of the lock, when in the locked position, is adapted to operatively engage a portion of the firing mechanism of the firearm to prevent operation of the firearm. The invention is quickly installed by replacing an existing grip or stock of the firearm with grips or stocks according to the invention.

A draw bar lock for a firearm is operable to engage and disengage a draw bar or trigger bar of the firearm, which connects the trigger to the hammer. The lock includes a lock member which, in the locked position, operatively engages the draw bar to move the draw bar out of engagement with the hammer. The firearm is thereby rendered inoperative. The lock member, in the unlocked position, permits the draw bar to engage the hammer in the usual manner to permit operation of the firearm. The lock member can be provided as part of a lock assembly which can be readily installed in the firearm, and in a construction which is resistant to tampering.

#### 15 Brief Description of the Drawings

There are shown in the drawings embodiments which are presently preferred it being understood, however, that the invention is not limited to the precise arrangements or instrumentalities shown, wherein:

Fig. 1 is a perspective view of an automatic hand gun having a lock according to the invention.

Fig. 2 is an exploded front perspective.

Fig. 3 is an exploded rear perspective of a lock according to the invention.

Fig. 4 is an exploded perspective of a ratchet member and key-way carrier.

Fig. 5 is a rear elevation, partially broken away and partially in phantom.

Fig. 6 is a rear elevation, partially in phantom, and depicting an unlocking mode of operation.

Fig. 7 is a rear elevation similar to Fig. 5, and depicting a reset mode of operation.

Fig. 8 is a perspective view of a gun lock according to the invention as installed in a revolver.

Fig. 9 is an exploded perspective of the embodiment of Fig. 8.

Fig. 10 is a perspective, partially broken away, and in an unlocked mode of operation.

Fig. 11 is a perspective, partially broken away, and in a locked mode of operation.

Fig. 12 is a perspective view of a grip lock assembly according to the invention.

Fig. 13 is an exploded perspective of an alternative lock construction.

Fig. 14 is a front elevation of the lock construction of Fig. 13 as installed, the surrounding portions of the handle grip being removed to depict internal features, the lock being in a first, "locked" mode of operation.

Fig. 15 is a side elevation similar to that of Fig. 14, and depicting the lock in a second, "unlocked" mode of operation.

Fig. 16 is a perspective view of a firearm with a draw bar lock according to the invention.

Fig. 17 is a side elevation, partially broken away and partially in phantom, and depicting a first mode of

operation.

Fig. 18 is a side elevation opposite to that of Fig. 17, partially broken away and partially in phantom, and depicting the first mode of operation.

Fig. 19 is a side elevation similar to Fig. 18, and depicting a second mode of operation.

### Best Mode for Carrying Out the Invention

An embodiment of the invention suitable for automatic hand guns is shown in Figs. 1-6. The hand gun 20 includes a handle frame 24, slide 28, hammer 30, trigger 32, and safety 34, which can be according to known hand gun constructions. The safety 34 is depicted in the "safe" position in Fig. 1. Clockwise pivoting of a finger piece portion 36 of the safety 34 will place the safety in the "unsafe" position, which is necessary to operate the firearm.

A lock 40 according to the invention is provided and includes an engagement portion 46 which, in a locked position, blocks the safety 34 so as to prevent movement of the safety 34 to the "unsafe" position. In an unlocked position, the engagement portion 46 is positioned out of operative engagement with the safety 34 so as to permit the safety 34 to be moved to the "unsafe" position. The firearm can then be operated in the usual manner.

The lock 40 can be constructed according to several alternative lock constructions. Combination locks are most preferred because keys or other pieces are not necessary to unlock the lock. These other pieces can be lost, misplaced, or left behind, which could render the firearm unoperable to the authorized user in an emergency situation. Push buttons 50a-c are provided, although fewer or more push buttons can alternatively be utilized. The push buttons 50a-c could potentially be replaced by other combination lock structure, such as rotating dials or touch pads.

The precise size and configuration of the handle frame 24 can vary from firearm to firearm. It has been found to be useful to provide a mounting plate 58 by which the lock 40 can be mounted to several different types of firearms without substantially changing the lock 40. The mounting plate 58 can be attached to the handle frame 24 by suitable structure, such as the screw 62 which passes through aperture 64 in the mounting plate 58 to engage a female threaded socket 68 in the handle frame 24. A threaded screw 70 can be positioned through an aperture 71 to secure the mounting plate 58 to the handle frame 24 at a female threaded socket 73. The screw 70 can be provided with a female socket 72 at the head so as to receive a screw 76. The screw 76 is useful to secure a handle grip 78 to the handle frame 24. The handle grip 78 can be configured to fit around a portion of the lock 40.

Structure is provided for engaging the lock 40 to the mounting plate 58. A flange 80 can be provided which hingably engages cooperating structure on the lock 40.

A screw 82 can engage the lock 40 to a threaded socket 84 in the mounting plate 58. Further, structure on the lock 40 is preferably provided which, when in the locked position, engages a clasp portion 88 on the mounting plate 58 so as to prevent removal of the lock 40 from the mounting plate 58 when the lock 40 is in the locked position. The screw 62 used to secure the mounting plate 58 to the handle frame 24 is covered by the lock 40, and since the lock 40 cannot be removed from the mounting plate 58 when in the locked position, the mounting plate 58 also cannot be removed when the lock 40 is in the locked position.

A preferred lock construction is shown in Fig. 3. The lock 40 includes a lock housing 92. A push button finger piece 96 is associated with each of the push buttons 50a-c and extends through openings 100-102 that are provided in the housing 92. A pawl 106 is connected to each of the push buttons 50a-c. In a preferred embodiment, an extension arm 112 connects each pawl 106 to the push buttons 50a-c. The pawls 106 are preferably pivotally connected to the extension arms 112 as by pivot pin 118. Each pawl 106 includes an engagement portion 120 which is adapted to engage an elongated ratchet member 124. The ratchet member 124 can have plurality of ratchet teeth 128 for engagement with the engagement portion 120 of the pawls 106 (Fig. 4). Biasing structure such as a ratchet return spring 132 is adapted to urge the ratchet members 124 toward the respective push buttons 50a-c. The ratchet return spring 132 can be secured by mounting pins 136 fixed to the housing 92 and to mounting pins 140 on the ratchet members 124.

Detents 144 are provided to retain each ratchet member 124 against the force of the ratchet return spring 132 following movement of the ratchet member 124 by the pawl 106. The detents 144 can include engagement portions 148 which are adapted to engage the teeth 128 of the ratchet members 124. The detents 144 can be pivotally mounted to the housing 92 by suitable structure such as pivot pins 152.

The pawls 106 and detents 144 preferably are biased into engagement with the ratchet members 124 so as to prevent slippage. One or more biasing springs, such as the biasing spring 156, can be provided to perform this function. The biasing spring 156 can have spring arms 158, 159 which contact the pawls 106 and detents 144. The biasing spring 156 can be mounted in suitable fashion, such as to the mounting posts 160.

The pawls 106 and ratchet teeth 128 are configured according to known ratchet constructions so as to provide for engagement during a downward stroke of the push buttons 50a-c, and slippage of the pawl 106 past the ratchet teeth 128 during the return stroke of the push buttons 50a-c. Return of the push buttons 50a-c is accomplished by push button return springs 164 associated with each of the push buttons 50a-c, which are adapted to bias the push buttons 50a-c away from the ratchet members 124. The detents 144 are constructed in

known fashion so as to engage the ratchet members 124 oppositely to the pawls 106, such that the ratchet teeth 128 can move past the detents 144 when the ratchet members are moved by the pawls 106.

Structure may be provided to guide the sliding movement of the ratchet members 124 and the pawls 106. In one embodiment, rails 168 are provided with the housing 92 and are adapted to slidably engage a groove 170 formed in a back surface of each ratchet member 124. Grooves 172 can be formed in the housing 92 for guiding the movement of the ratchet members. Pawl guides 176 can also be provided with the housing 92 to guide the motion of the pawls 106. Ratchet stops 180 can be provided to limit the movement of the ratchet members 124 in response to the biasing of the ratchet return springs 132.

Key-way carriers 190a-c are associated with each of the ratchet members 124 and adapted to move with movement of the ratchet members 124. In a preferred embodiment, the key-way carriers 190 are detachably engaged to the ratchet members 124, such as by tongue 192 and groove 193 construction. Each key-way carrier 190a-c includes a respective key-way 194a-c, which can be formed as a notch or groove therein.

A lock slide 200 is operatively connected to the engagement portion 46 and can extend through a suitable opening 204 in the housing 92. The lock slide 200 includes keys 206a-c which, when assembled, are positioned substantially adjacent to respective key-way carriers 190a-c. The lock slide 200 and keys 206a-c are juxtaposed to the key-way carriers 190a-c such that transverse movement of the lock slide 200 relative to the key-way carriers 190a-c is blocked by contact between the keys 206a-c and the key-way carriers 190a-c.

The key-ways 194a-c are dimensioned to accept the keys 206a-c. Alignment of the key-ways 194a-c with the keys 206a-c is accomplished by depressing the respective push buttons 50a-c the appropriate number of times corresponding to the position of the key-way 194a-c on the respective key-way carrier 190a-c. A key-way 194 that is positioned nearer to the end of the ratchet member 124 that is closest to the respective push button 50 will require more operations of the push button 50 in order to move the ratchet member 124 and associated key-way carrier 190 a sufficient distance to align the key-way 194 with the respective key 206. Different positions of the key-way 194 on the key-way carrier 190 will require more or fewer operations of the push button 50. Accordingly, the relative positioning of the key-ways 194a-c on the respective key-way carriers 190a-c corresponds to a combination necessary to align all of the key-ways 194a-c with the keys 206a-c, so as to permit transverse movement of the keys 206a-c into the key-ways 194a-c, and corresponding movement of the lock slide 200. The engagement portion 46 will move with the lock slide 200 to the "unlocked" position.

A lock slide biasing spring 210 can be provided to urge the lock slide 200 to the unlocked position in which

the keys 206a-c are urged into the key-ways 194a-c. The biasing spring 210 can be mounted to the lock slide 200 at a mounting post 214, and can be engaged to a portion of the housing at a post 218 (Fig. 4).

Reset structure is provided for returning the ratchet members 124 to an initial position, which will move the key-ways 194 out of alignment with the keys 206 to lock the lock 40, and so that the combination can be entered from a consistent starting point. The reset structure can engage the pawls 106 and detents 144 to move them out of engagement with the ratchet members 124. The ratchet return springs 132 will move the ratchet members 124 to an initial position defined by the ratchet stops 180. A reset slide 220 can be provided with a plurality of reset arms 222. The reset slide 220 is so constructed that, when assembled, the reset arms 222 are juxtaposed to the pawls 106 and detents 144, which extend somewhat out of the plane of the ratchet members 124. The reset slide 220 is slidably disposed within the lock 40, and can be supported by a portion 226 which is slidably engaged in a slot 230 formed in the housing 92. A slot 234 can be provided to receive a mounting screw 238, which engages a threaded socket 240 in the housing 92 so as to provide slidable engagement of the reset slide 220 to the housing 92. A reset button 248 of the reset slide 220 can extend out of an opening 250 in the housing 92 for manipulation by the operator. Sliding movement of the reset slide 220 will cause contact between the reset arms 222 and the pawls 106 and detents 144, to move the pawls 106 and detents 144 out of engagement with the ratchet teeth 128 of the ratchet members 124.

In operation, when the lock slide 200 is in the locked position, the engagement portion 46 will be positioned so as to prevent movement of the safety 34 from the "unsafe" position. Keys 206a-c abut the respective key-way carriers 190a-c such that movement of the lock slide 200 to the unlocked position is not possible. Upon operation of the respective push buttons 50a-c, the key-ways 194a-c are aligned with the keys 206a-c. The lock slide 200 is urged by the lock slide spring 210 such that the keys 206a-c are moved into the respective key-ways 194a-c. The lock slide 200 and engagement portion 46 thereby are permitted to move from the locked position to the unlocked position, permitting movement of the safety 34 to the "unsafe" position, and operation of the firearm. Locking of the firearm can be accomplished by manually moving the engagement portion 46 and lock slide 200 to the locked position in which the keys 206a-c are out of engagement with the key-ways 194a-c. The lock slide 220 must be held against the biasing of the lock slide spring 210, so that accidental locking is avoided. Movement of the reset button 248 and reset slide 220 will cause the reset arms 222 to move the ratchet pawls 106 and the detents 144. This will permit movement of the ratchet members 124 and associated key-way carriers 190a-c to the initial position in which movement of the keys 206a-c is blocked by the key-way car-

riers 190a-c. This will lock the lock 40 and will also position each of the ratchet members 124 at the initial position defined by the ratchet stops 180 for subsequent entering of the combination.

Movement of the pawls 106 and detents 144 out of engagement with the ratchet members 124 prior to the completion of the movement of the keys 206a-c out of the respective key-ways 194a-c can result in dragging of one or more of the keys 206a-c against sides of the respective key-way carriers 190a-c. This will impede the return of the key-way carrier 190 and respective ratchet member 124 to the initial position during the reset function. The subsequent release of the reset button 248 will cause the ratchet pawls 106 and detents 144 to engage the respective ratchet member 124, which may not have returned fully to the initial position because of the dragging against the keys 206. Entering of the appropriate combination will be confused because the ratchet member 124 and key-way carrier 190 will not be in the true starting position. It is therefore desirable to provide structure to ensure that the reset button 248 is not operable until the lock slide 200 and keys 206a-c are completely out of engagement with key-way carriers 190a-c.

A pivoting reset stop lever 256 can be provided and can be pivotally secured to the housing 92 as by a mounting pin 260. A spring 262 biases the reset stop lever 256 into engagement with a shoulder 266 on the reset slide 220. Completion of the movement of the lock slide 200 to the locked position causes contact between the lock slide 200 and the reset stop lever 256 so as to pivot the lever out of engagement with the reset slide 220. The reset slide 220 can then be operated to reset the position of the ratchet members 124.

It is also desirable that structure be provided to urge the lock slide 200 completely out of engagement with the key-way carriers 190a-c during the reset function. The lock slide spring 210 may otherwise cause excessive contact between the keys 206a-c and the key-way carriers 190a-c. A reversing lever 270 can be pivotally mounted to the housing 92, as by a mounting pin 274. The reversing lever 270 includes a pin 271 that is contacted by an elongated slot 272 on the reset slide 220 when the reset slide is moved during the reset operation. The contact will pivot the reversing lever 270 and cause shoulder 282 of the reversing lever 270 to contact a shoulder 286 of the lock slide 200 to urge the lock slide 200 and keys 206a-c securely out of engagement with the key-way carriers 190a-c.

The key-way carriers 190 can include alternate key-ways 290 substantially on a side of the key-way carrier 190 opposite the key-way 194. The fastening structure such as the tongue 192 and groove 193 is such that the key-way carrier 190 can be inverted to face the alternate key-way 290 to the lock slide 200 and keys 206. The alternate key-way 290 can be at a different position along the key-way carrier 190 such that inversion of the key-way carrier 190 will result in alteration of the combination necessary to align the alternate key-way 290

with the respective key 206 to open the lock. The combination can thereby be readily changed if it becomes known to unauthorized users.

It is preferable that structure be provided to prevent the removal of the lock itself by unauthorized users and, as stated earlier, a catch 88 on the mounting plate 58 can be aligned with a cooperating catch 302 on the lock housing 92. A portion 298 of the lock slide 200 moves behind the catch 88 and in front of the catch 302 when the lock slide 200 is in the locked position. The mounting plate 58, lock slide 200, and housing 92 will thereby be interconnected to secure the lock 40 to the mounting plate 58 when the lock 40 is in the locked position. Further, the lock housing 92 covers and prevents access to the mounting screw 62, which secures the mounting plate 58 to the frame 24. The interconnecting structure provides a construction whereby the lock 40 cannot be removed from the hand gun when the lock 40 is in the locked position.

An alternative embodiment of the invention is useful for revolvers. Revolvers do not include an external safety mechanism, and accordingly, another portion of the firing mechanism must be operatively engaged in the locked position to prevent operation of the firearm. Figs. 8-11 depict such an embodiment of the invention for a revolver 306. In this embodiment, a lock 310 is provided with an engagement portion 314. The lock 310 can be similar in construction to the lock 40 described above, or can be made according to a different construction, including locks that are not combination locks.

Operation of the firearm 306 requires rearward pivoting of a hammer 308 upon squeezing of a trigger 312. A hammer stirrup 316 is engaged to the hammer 308 according to known firearm constructions. A hammer return spring 318 is provided to propel the hammer stirrup 316 and hammer 308 during firing of the weapon. An end 319 of the hammer stirrup 316 in some firearm constructions extends into an opening 326 of the frame 330 of the firearm.

A mounting plate 320 can be provided and secured to the firearm 306 by suitable fastening structure. In one embodiment, a screw 344 is passed through an aperture 348 in the mounting plate 320 and engaged to a suitable socket 352 in an opposing handle grip 356. The mounting plate 320 will then be secured to the frame 330 of the firearm 306.

A lever 366 is provided and can be pivotally mounted to the mounting plate 320 through a mounting aperture 370 which is secured to a mounting pin 374 on the mounting plate 320. A second, blocking lever 380 is pivotally mounted to the mounting plate 320, as by a mounting aperture 384 which is positioned on a mounting post 390 of the mounting plate 320. The first lever 366 can be engaged to the blocking lever 380 by a suitable engagement post 381 on the first lever 366, which cooperates with an engagement groove 383 on the blocking lever 380.

In a first, unlocked position, the blocking lever 380

is positioned out of alignment with the end 319 of the hammer stirrup 316 (Fig. 10). Normal operation of the firearm is thereby permitted. In a locked position, however, the engagement portion 314 engages and pivots the first lever 366 clockwise and secures it in this pivoted position. Pivoting of the first lever 366 causes counter-clockwise pivoting of the blocking lever 380. A blocking portion 388 of the blocking lever 380 is moved over the end portion 319 of the hammer stirrup 316 to prevent movement of the hammer stirrup 316 and operation of the weapon.

Structure can be provided to fix the position of the blocking lever 380. A suitable spring 400, such as a leaf spring, can be secured through a mounting aperture 404 by a screw 408, which engages a suitable socket 412 in the mounting plate 320. A groove 416 in the mounting plate 320 is adapted to receive a portion of the leaf spring 400 and provides additional fastening structure. The spring 400 includes either of a tit or a dimple to cooperate with two corresponding tits or dimples on a surface 426 of the blocking lever 380. A dimple 428 can engage either of tits 434, 436 to secure the blocking lever in either the locked or unlocked position.

The lock 310 can be secured to the mounting plate 320 by suitable structure such as a screw 444 which engages a suitable threaded opening 446 on the mounting plate 320. A flange 450 can be provided to engage a corresponding portion of the lock 310. Further, a catch 454 can be provided to engage a portion of the lock, such as a portion of the lock slide as previously discussed, to prevent removal of the lock 310 from the mounting plate 320 when the lock is in the locked position. The lock also covers the mounting screw 344 such that an interconnecting structure is provided wherein the lock 310 cannot be removed from the firearm 306 when the lock 310 is in the locked position. A handle grip 460 can be fashioned to fit over the lock 310 and secure to the mounting plate 320 as by a screw 436 engaging an aperture 438.

The safety mechanism of the invention can be used, with minor modification, in gun designs of many descriptions. The operation of most handguns and long arms is well understood, and described in several volumes including the Gun Digest Book of Firearms Assembly/Disassembly, Parts I and II; Automatic Pistols and Revolvers, by J.B. Wood, D.B.I. Books, Inc., Northbrook, IL, 1979; The S&W Revolver, A Shop Manual, Jerry Kuhnhausen, V.S.P. Publishers, Department 1A, Box 1966, Tusten, CA 92681; The Colt 45 Automatic, A Shop Manual, Jerry Kuhnhausen, V.S.P. Publishers, Department 1A, Box 1966, Tusten, CA 92681; and the NRA Guide to Firearms Assembly, National Rifle Association of America, 1600 Rhode Island Avenue N.W., Washington, D.C. 20036. The disclosures of the above-identified references are herein fully incorporated by reference. The invention can be utilized with automatic firearms such as the Beretta model 84BB, manufactured by the Fabbrica d'ArmiPietro Beretta S.P.A. of Via Pietro Ber-

etta, 18-25063 Gardone Val Trompia, Brescia, Italy. The weapon is fully described in the Owner's-Manual Beretta dal 1526, Series 81, distributed by the company, which manual hereby is fully incorporated by reference.

The invention can also be utilized with the Smith & Wesson semiautomatic centerfire pistols, manufactured by the Smith & Wesson Company of 2100 Roosevelt Avenue, Springfield, MA. The weapons are fully described in the Safety Instruction & Parts Manual, distributed by the company, which manual is hereby fully incorporated by reference.

There are shown in Figs. 12-15 a grip lock assembly according to the invention in which a lock is operatively incorporated into a handle grip for the firearm. The lock may easily be installed into the firearm by replacing the existing grip of the firearm with a grip according to the invention. The automatic handgun 516 depicted in Figs. 12-15 includes a barrel 520, handle frame 526, and slide 530, and hammer 531. An existing external safety mechanism 534 is adapted for upward movement into slots 538 formed in the slide 530 to prevent rearward movement of the slide 530 and cocking of the hammer 531, and thus operation of the firearm. The safety 534 can be moved downward out of the slots 538 to permit rearward movement of the slide 530 and operation of the firearm.

According to the invention, a lock 540 is provided in a handle grip 542 that is adapted for installation into the firearm 516. The lock 540 includes structure for engaging a portion of the firing mechanism of the firearm 516 so as to, in a locked position, prevent operation of the firearm. The portion of the firing mechanism which can be engaged can be varied depending on the type and style of the firearm. In an embodiment suitable for use with automatic firearms such as the firearm 516, the lock 540 can be designed to work with the existing external safety mechanism 534 of the firearm. The lock 540 includes a lock portion such as the locking bar 546 which is moveable to a position immediately beneath the safety 534.

The lock 540 can be selected from many different types of locks, including key locks, dialed combination locks, and the like. It is preferable, however, to provide a combination lock which is opened by entering the appropriate combination in one or more push members such as buttons. In this manner, external devices such as keys which are susceptible to loss are not necessary, and the combination can be entered in dark environments by simply sensing the location of the respective push buttons and entering the appropriate combination. Suitable lock constructions are also disclosed in Applicant's U.S. Patent No. 4,987,693. The disclosures of this patent are hereby incorporated fully by reference.

An alternative embodiment of a suitable lock construction is shown particularly in Figs. 13-15. The locking bar 546 can be extended through a slot 550 in a lock housing. In a first position, the locking bar 546 is beneath the safety 534 of the handgun 516 (Fig. 14). The locking

bar 546 will prevent movement of the safety 534 out of the groove 538 to the "unsafe" position. Entering the proper combination into the lock 540, however, will permit the locking bar 546 to be moved to an unlocked position (Fig. 15) away from abutment with the safety 534. The safety 534 can be manipulated between the "safe" and "unsafe" positions in the usual manner when the lock 540 is in the unlocked position, and the firearm can be operated to move the slide 530 rearward and cock the hammer 531.

The lock 540 can include a housing which can be mounted directly to an exterior surface of the handgun 516 directly below the safety 534, or the lock can be mounted directly in the handle grip 542 as shown. The lock can be provided with a complete lock housing having a front face formed by the handle grip 542, a top face 552, a bottom face 554, a back face 558, and side faces 560, 562. At least one ratchet member, and preferably three elongated ratchet members 568-570 as shown, are movably mounted by pins 571 which extend through slots 572 in the housing to slidably engage the ratchet members 568-570 to the housing. Each of the ratchet members can have a plurality of substantially aligned ratchet teeth 574 which have a ramp surface 578 which slopes outwardly from the long axis of the ratchet member. The ramp surface 578 terminates in a substantially planar notch surface 580 (Fig. 15). Biasing as by springs 584 is provided to move each ratchet member substantially along the long axis of the ratchet member.

Catch members such as detents 588 are provided to engage the notch surfaces 580 to prevent further movement under the bias of the springs 584. The detents 588 are biased into a position of engagement with the teeth 574 by suitable biasing means such as the leaf spring 590. The leaf spring 590 can engage a mounting pin 592 at an end of the detent 588, and a shaft 594 that is fixed to the back plate 558 and to which the detent 588 is pivotally mounted.

Movement of the ratchet members 568-570 can be accomplished by a push rod 600 having at one end a foot 602 adapted to engage the teeth 574. The push rod 600 is tangentially aligned with the ratchet members 568-570 in such a manner that axial movement of the push rod will engage the foot 602 with the notch surface 580 of the ratchet teeth 574 to move the ratchet member substantially along its long axis. A button head 610 or other push member is fixed to an end of the push rod 600 opposite the foot 602 and extends through the top plate 552 of the housing to allow for manipulation by the user.

The throw of the push rod 600 is at least equal to the length of one of the ratchet teeth 574. Movement of the ratchet member will cause the detent 588 to travel over the ramp surface 578 against the bias of the leaf spring 590 and subsequently to engage the notch surface 580 of the next succeeding tooth 574. The push rod 600 can be biased toward its original position by suitable means such as a coil spring 614, which is disposed

between a flange 618 on the button 610 and an inside surface 620 of the housing. When pressure on the button head 610 is relaxed, the spring 614 will return the push rod 600 to the original position. The push rod 600 can have a thinned portion 622 which permits the push rod 600 to spring outward over the ramp surface 578 of the succeeding tooth as the ratchet member moves. The push rod 600 will spring inward as it passes the notch surface 580 of the succeeding tooth, and will be positioned for another throw. The ratchet member is thereby incrementally moved by the discreet operations of the push rod 600.

The combination required to open the lock can be determined by the position of protrusion-receiving lock channels. These channels can be formed in the ratchet members by several suitable configurations. In a preferred configuration, removable stop members such as screws 636 are secured into suitable apertures formed in each of the sprocket members 568-570. The locking bar 546 is engaged to a slide bolt 640. The slide bolt 640 includes locking protrusions 644, one of which is positioned adjacent to each ratchet member 568-570. The protrusions 644 are substantially parallel with the surface of each of the ratchet members 568-570, and are oriented so as to be substantially transverse to the long axis of each ratchet member. The screws 636 extend for a distance from the surface of each of the ratchet members 568-570, such that transverse movement of the projections 644 across the ratchet members 568-570, and therefore also movement of the slide bolt 640 and the locking bar 546, will be prevented when in the locked position (Fig. 14). Absence of screws, as from the threaded apertures 630-632, will create protrusion-receiving lock channels which will receive the protrusions 644 and permit movement of the slide bolt 640 and locking bar 546.

Operation of the push rods 600 will move the ratchet members in increments corresponding to the teeth 574. A given number of discreet movements of the push rods 600 by the buttons 610, equivalent to the combination, will align the channels corresponding to the apertures 630-632 with the protrusions 644. The left-hand ratchet member in Fig. 14 will require one movement for alignment to occur, the center ratchet member 569 will require four, and the right-hand ratchet member 570 will require one. When each of the buttons 610 have been depressed the proper number of times, all the channels will be aligned with the protrusions 644. The protrusions 644 can then slide into the channels (Fig. 15) with corresponding movement of the slide bolt 640. The locking bar 546 can then be moved from beneath the safety 534, whereupon the safety 534 can be operated in the usual manner. It will be readily appreciated that the combination may be easily changed by removing one of the screws 636 on a ratchet member and placing it into a presently unfilled aperture. This will close the prior receiving channel and create a new channel corresponding to a different combination.

It is desirable for this embodiment that the operator be able to repeatedly initialize the ratchet members to the same starting position relative to the push rods 600. The operator may inadvertently enter the wrong number into the device, or may lose count of the number that has been entered. The combination must be reentered. The operator may start over by returning the ratchet members to a "0" position and repeating the process of entering the combination. This can be accomplished by provision of structure adapted to move the detents 588 and push rods 600 from engagement with the teeth 574 so that the ratchet members 568-570 can move under the bias of the springs 584. An elongated reset arm 660 can be slidably mounted within the housing in an adjacent alignment with the push rods 600 and the detents 588. The reset arm 660 can have slots 664 which can be axially aligned with the long axis of the reset arm 660. Pins 666 can be fixed to the back face 558 of the housing and slidably mount in the slots 664. The reset arm 660 can then slide past the mounting pins 666 and relative to the detents 588 and push rods 600.

A plurality of push rod cam pins 670 are fixed to the reset arm 660 so as to be substantially adjacent to the push rods 600. A plurality of detent cam pins 674 are fixed to the reset arm 660 so as to be substantially adjacent to the detents 588. The push rod cam pins 670 and detent cam pins 674 extend outwardly from the reset arm 660 such that they contact the push rods 600 and the detents 588 when the reset arm 660 is moved axially through the housing.

The reset arm 660 extends through the side face 562 of the housing, and can be fitted with a button 678 for manipulation by the user. A spring 680 is disposed between a seat 682 in the housing and flange 686 on the button 678. The spring 680 is adapted to bias the reset arm 660 to a position wherein push rod cam pins 670 and the detent cam pins 674 are substantially removed from contact with the push rods 600 and the detents 588, respectively, or to the right in Fig. 14.

The reset function is performed by depressing the reset button 678. This moves the push rod cam pins 670 and detent cam pins 674 into contact with the push rods 600 and detents 588, respectively. The push rods 600 are moved by the cam pins 670 to the left in Fig. 14 and the detents 588 are pivoted by the motion of the detent pins 674, to a position out of contact with the ratchet teeth 574. The ratchet members 568-570 can then move under the bias of the springs 584 to the starting position (Fig. 14). Movement of the ratchet members is halted by stop surfaces 690 which project downwardly from the inside surface 620 of the housing. The ratchet members 568-570 will then be moved to the locked, starting position each time the reset button 678 is depressed. The operator may then reenter the combination when operation of the firearm is desired.

The use of the invention will be described with reference to a Smith & Wesson semiautomatic centerfire pistol, manufactured by The Smith & Wesson Company

of 2100 Roosevelt Avenue, Springfield, MA. The weapon is fully described in the Safety Instruction & Parts Manual, distributed by the company, which manual hereby is fully incorporated by reference.

5 There is shown in the drawings a firearm 710 which has a draw bar 722 connecting the trigger 714 and the hammer 720. The trigger 714 can be pivotally mounted about a mounting pin 726, and the hammer 720 can be pivotally mounted about a mounting pin 728. The operation of the draw bar is known in the art, in a variety of configurations, and the following explanation is intended only as an example. A draw bar engagement portion 730 of the trigger 14 is adapted to abut a trigger engagement portion 724 of the draw bar 722 when the trigger is operated. This action will move the draw bar 722 forward against the biasing of a return spring 738. A hammer engagement portion 732 of the draw bar 722 is adapted to engage a draw bar engagement portion 734 of the hammer 720, such that forward movement of the draw bar 722 will cause the hammer 720 to pivot about the pivotal mounting 728. The hammer 720 and draw bar 722 are configured in a manner known in the art such that the draw bar 722 will release the hammer 720 when the hammer 720 has rotated rearwardly to a pre-determined position. Spring biasing of the hammer is provided such that, in known fashion, the hammer 720 will rotate forward when released to strike the firing pin and fire the gun.

The draw bar 722 is provided in existing firearms as a safety which will prevent operation of the firearm when the magazine has been removed. The magazine fits into a shaft 740 in the handle frame 742 of the firearm, and is typically inserted through an opening in the base of the handle frame 742. In known fashion, removal of the magazine (not shown) from the handle frame 742 will permit the draw bar 722 to move out of engagement with the hammer 720, whereby operation of the trigger 714 will be ineffective to rotate the hammer 720 and operate the firearm. Accidental firing of the gun when the magazine has been removed is thereby prevented.

According to the invention, a lock is installed so as to be integral with the firearm. The lock has a draw bar engagement portion which is adapted to, in the locked position, move the draw bar 722 out of engagement with the hammer 720, whether or not the magazine of the firearm is in place. The lock assembly may be provided in a housing 750 as shown. Alternatively, the lock may be installed in a handle grip which replaces the existing handle grip of the firearm. This will facilitate the installation process and proper alignment with the draw bar 722. The lock assembly is mounted in a position of the firearm such that a drawbar engagement portion 754 of the lock will directly engage or substantially abut the draw bar 722. The draw bar engagement portion 754 can be provided in any configuration suitable for moving the draw bar 722 out of engagement with the hammer 720 when the lock is in the locked position.

The type of lock that is used can be selected from

a number of suitable lock designs. It is necessary only that the lock be configured such that, in the locked position, the draw bar 722 will be moved to a position out of engagement with the hammer 720, while in the unlocked position engagement of the hammer 720 by the draw bar 722 will be permitted. Desirable features include tamper resistance and a reduced size which will not interfere with normal operation of the firearm. It is also desirable that the lock be operable without the assistance of external accessories such as keys, which can be lost or misplaced and are difficult to manipulate in an emergency. It further is desirable that dials and other similar lock-opening constructions be avoided, as these cannot be utilized in dark environments and are also difficult to manipulate in an emergency. In a preferred embodiment, the lock includes push buttons 756 which operate to unlock the lock when the buttons have been pressed a proper number of times or in a proper sequential order.

According to Applicant's other lock constructions, a lock member 760 is moveable between locked and unlocked positions upon proper entry of a combination through utilization of push members such as the push buttons 756. A reset button 757 can be provided to initialize the lock for re-entering the combination. According to the present embodiment, a lever member 764 is pivotally connected to the lock assembly about a pivot mounting 766. The lever member 764 is mounted to the lock member 760 by a shaft 768, which can be mounted within a slot 770 formed in the lock member 760. The draw bar engagement portion 754 is provided on the lever member 764 and, upon installation, abuts the draw bar 722.

In the unlocked position (Figs. 17-18), the lock member 760 is in a first position in which the lever member 764 and draw bar engagement portion 754 are in a pivotal position whereby engagement of the hammer 720 by the draw bar 722 is permitted. The lock member 760 can be moved to cause the lever member 764 to pivot about the pivotal mounting 766, which movement will rotate the draw bar engagement portion 754 downward into contact with the draw bar 722, which will move the draw bar 722 out of engagement with the hammer 720, and thereby will prevent operation of the firearm. Upon entry of the appropriate combination or otherwise unlocking the lock, biasing can be provided to drive the lock member 760 to the original position, which will return the lever member 764, draw bar engagement portion 754, and draw bar 722 to the unlocked position of Figs. 17-18 to quickly render the firearm operable.

The invention provides a tamper-resistant construction which is easily locked against unauthorized use, yet which can readily be activated by unlocking the lock as by entering the appropriate combination. Since the lock operates in conjunction with the existing draw bar in the firearm, the lock is easily installed and will not otherwise affect the normal operation of the weapon.

The locks described in the above embodiments of

the invention require the user to enter the combination selection in the form of a predetermined number of discrete depressions of each button. Other combination selections are contemplated. For example, the combination could require the user to depress a plurality of buttons in a proper sequential order. Other types of lock mechanisms are also known in the art, and are within the scope of the present invention. The lock described can also have utility as a lock for items other than firearms, such as suitcases, briefcases, and jewelry boxes.

This invention can be provided in alternative embodiments which do not depart from the spirit or essential attributes thereof, and accordingly, reference should be had to the following claims, rather than to the foregoing specification, as indicating the scope of the invention.

## Claims

### 1. Lock for firearms, comprising:

a lock having a lock portion moveable with operation of the lock, the lock portion having a locked position in which the lock portion operatively engages a portion of the firing mechanism of the firearm so as to prevent operation of the firearm, and having an unlocked position permitting operation of the firearm;

a mounting plate for engagement to the firearm substantially at an external surface of the firearm, the mounting plate having structure for engaging the firearm and structure for engaging the lock.

### 2. Lock according to claim 1, characterized in that the structure for engaging the lock to the mounting plate is in part moveable with the lock portion, whereby the lock will be locked to the mounting plate when the lock is in the locked position, and releasable from the mounting plate when the lock is in the unlocked position.

### 3. Lock according to claim 1 or 2, characterized in that at least part of the structure for engaging the mounting plate to the firearm is shielded by the lock from external access, whereby removal of the lock and the mounting plate from the firearm cannot occur when the lock is in the locked position.

### 4. Lock according to any one of the preceding claims, characterized in that the lock has a lock housing adapted for installation at an external surface of the firearm;

the lock portion being connected to a lock slide, the lock slide being mounted substantially adjacent at least one elongated ratchet member,

each ratchet member having a biasing member associated therewith and adapted to urge the ratchet member to an initial position;  
 a push member extending through the housing and adapted to move the ratchet member against the biasing of the biasing member;  
 a detent adapted to engage the ratchet member following movement by the push member to prevent the return of the ratchet member to the initial position; and,  
 corresponding key and key-way portions on the ratchet members and the lock slide, movement of the ratchet member by the push member a distance corresponding to a lock combination being required to align the keys and key-ways to permit movement of the keys into the key-ways and movement of the lock slide and the lock portion.

5. Lock according to claim 4, characterized in that one of the keys and key-ways are provided on a carrier detachably engaged to the ratchet members, whereby the combination of the lock can be changed by changing the carriers.

6. Lock according to claim 5, characterized in that each carrier is capable of engagement to the ratchet members in at least two positions, each position presenting a different combination relative to the ratchet member.

7. Lock according to claim 5 or 6, characterized in that each carrier is elongated and includes a key-way on opposite sides thereof, whereby inversion of the carrier will alter the combination of the lock.

8. Lock according to any one of the preceding claims, characterized in that the firearm is a revolver having a hammer stirrup, the lock having a blocking portion moveable with operation of the lock, said blocking portion having a locked position in which the blocking portion operatively blocks movement of the hammer stirrup of the firearm so as to prevent operation of the firearm, and having an unlocked position permitting operation of the firearm.

50

55

FIG. 1

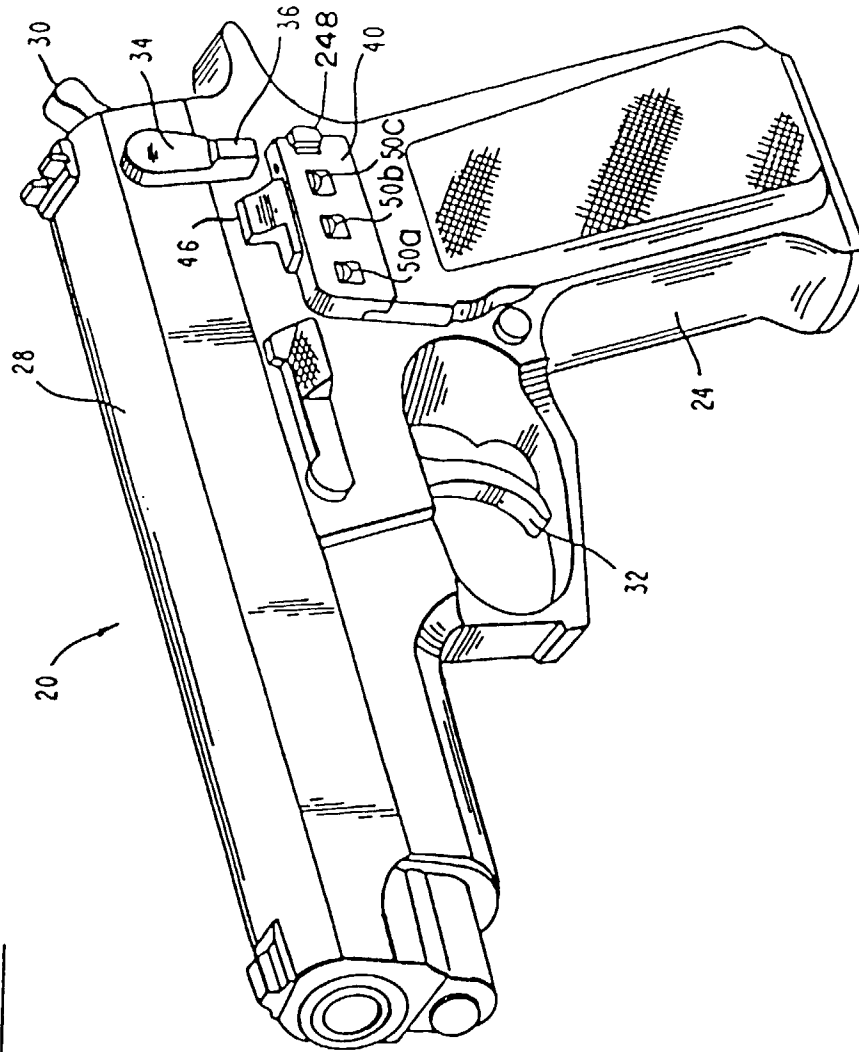

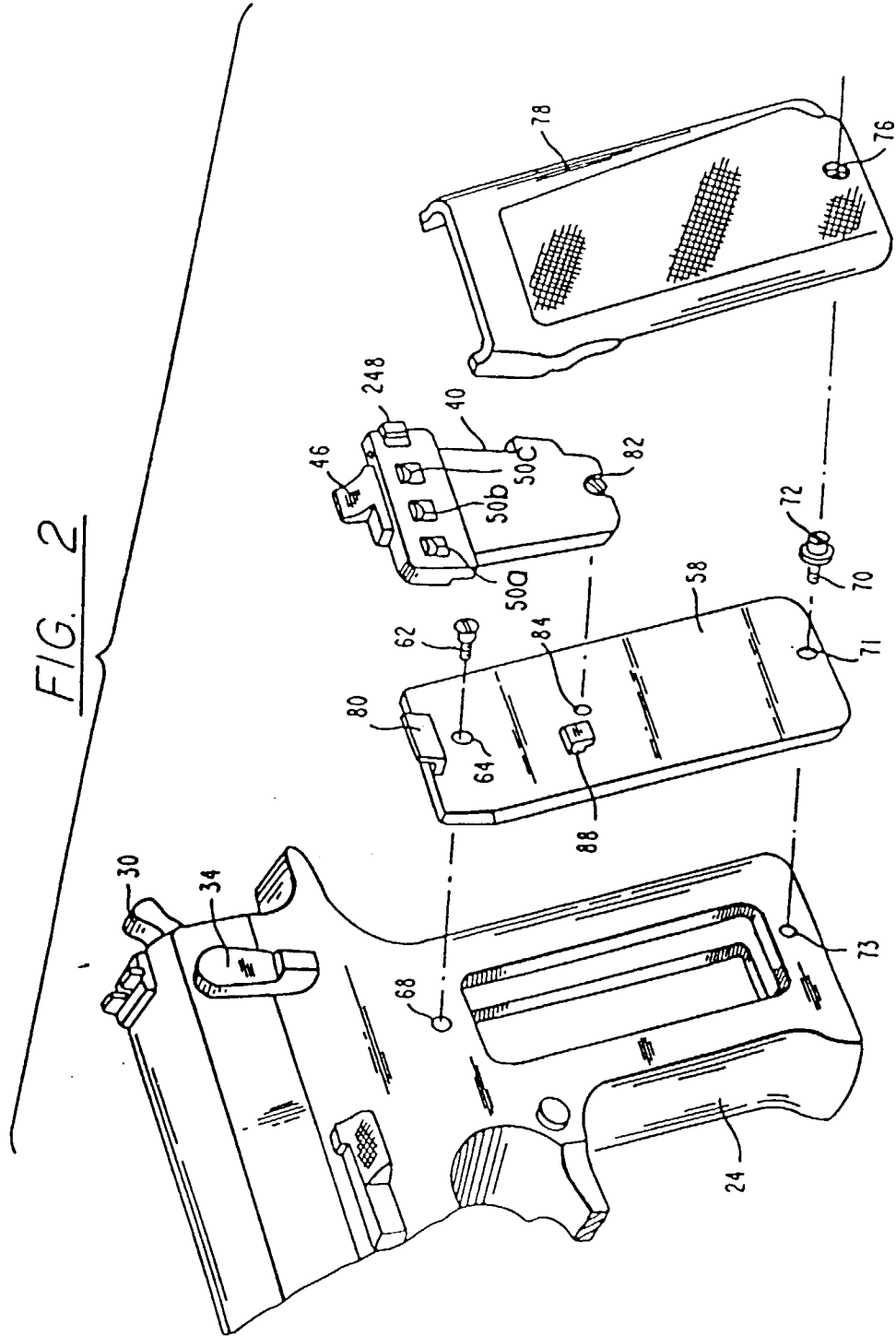

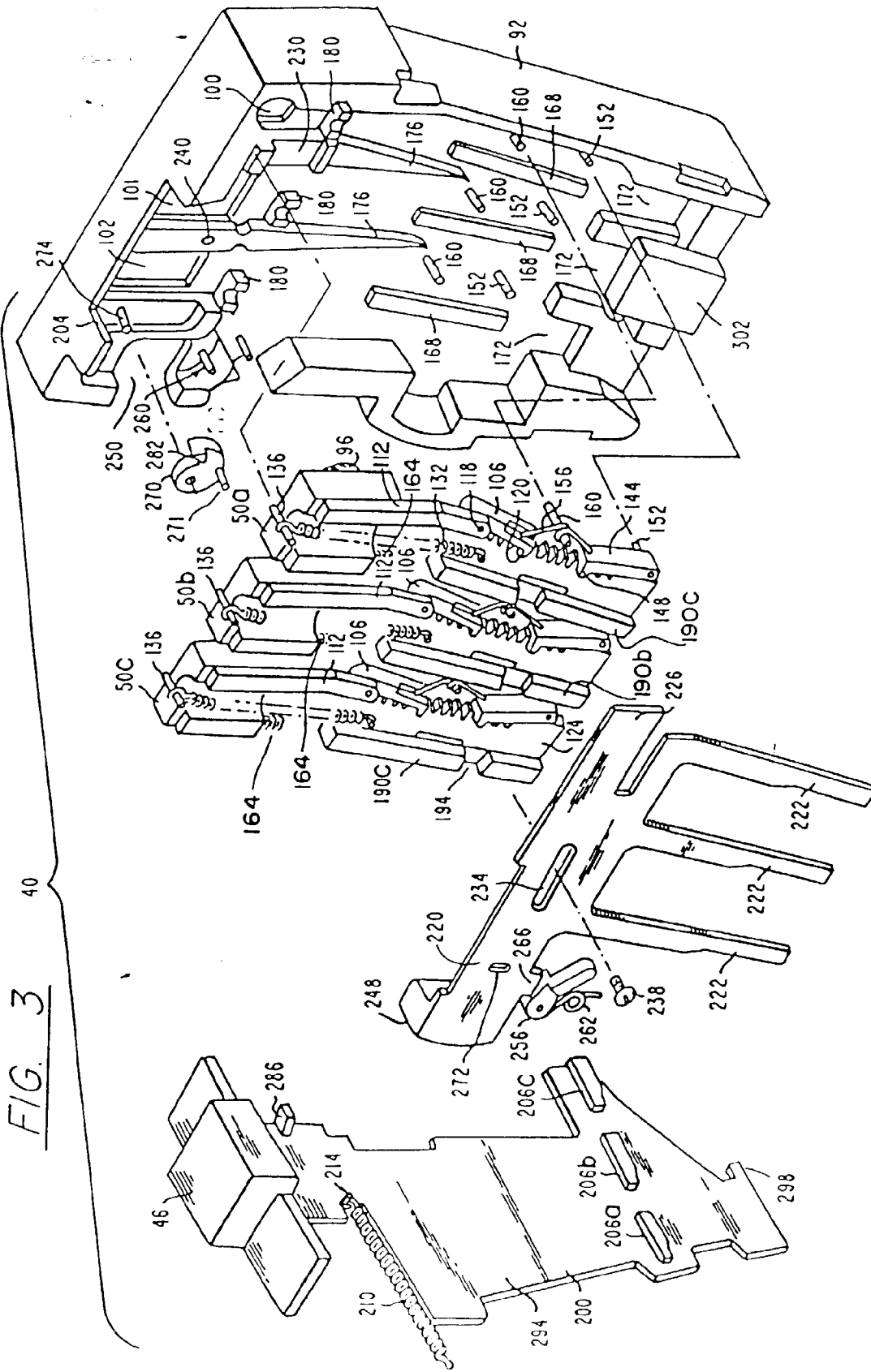

FIG. 3

40

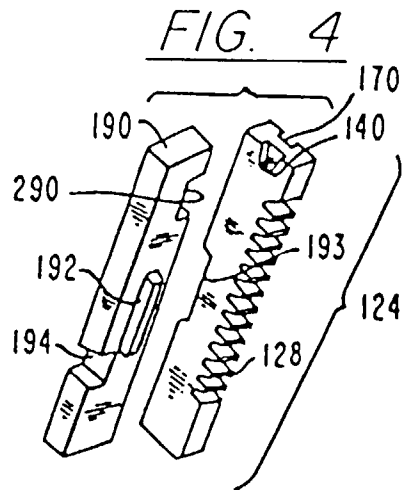

FIG. 5

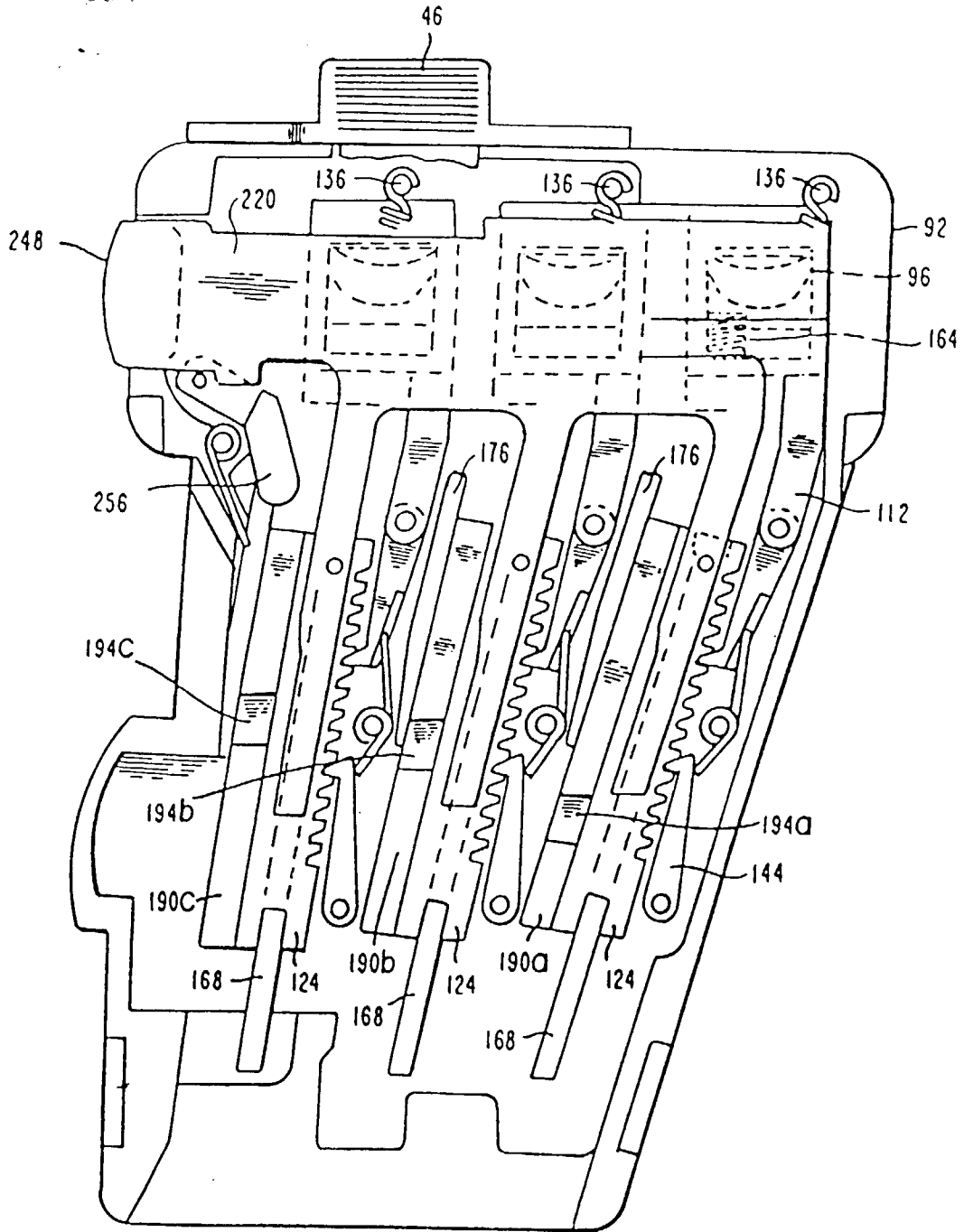

FIG. 6

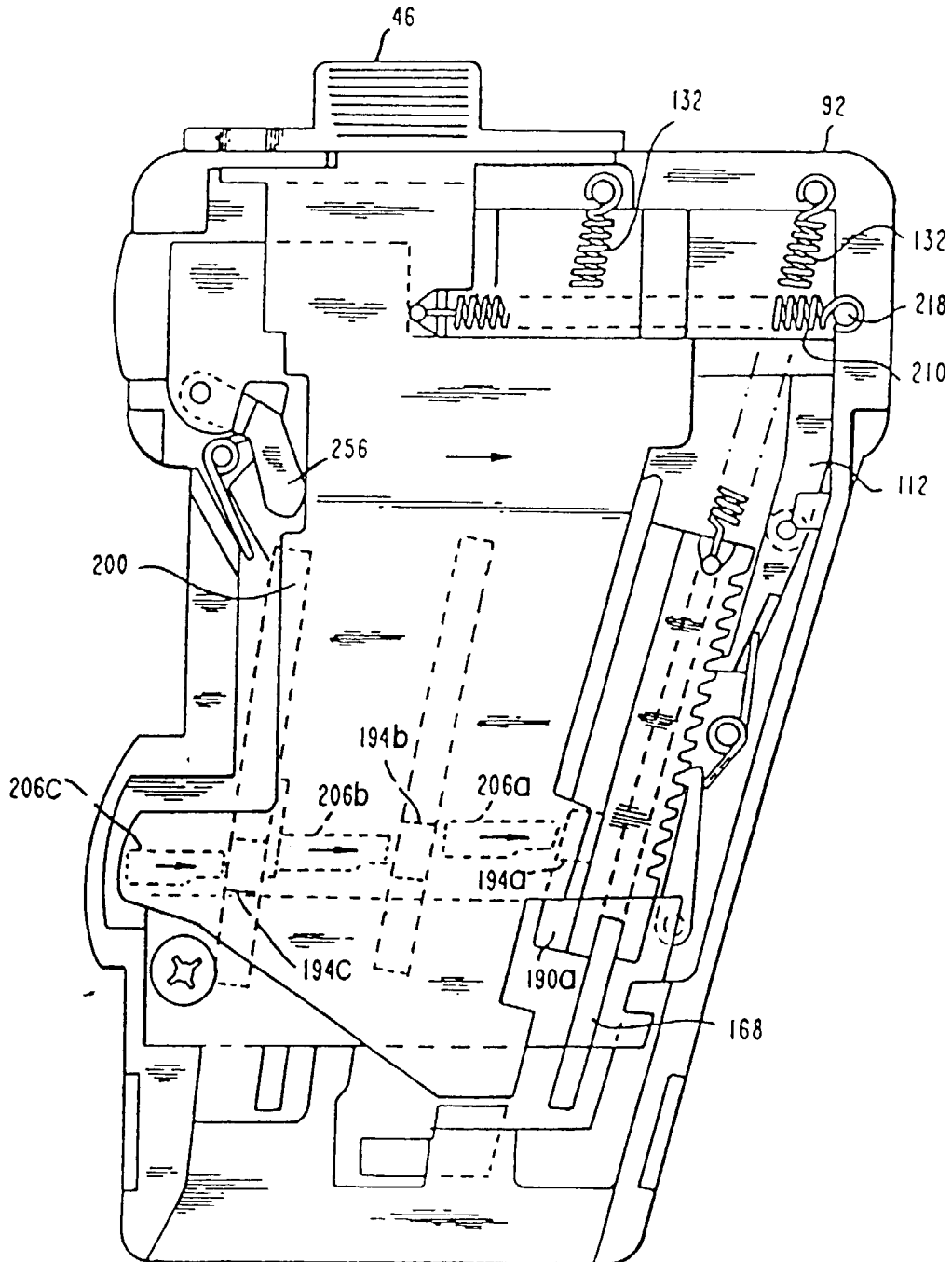
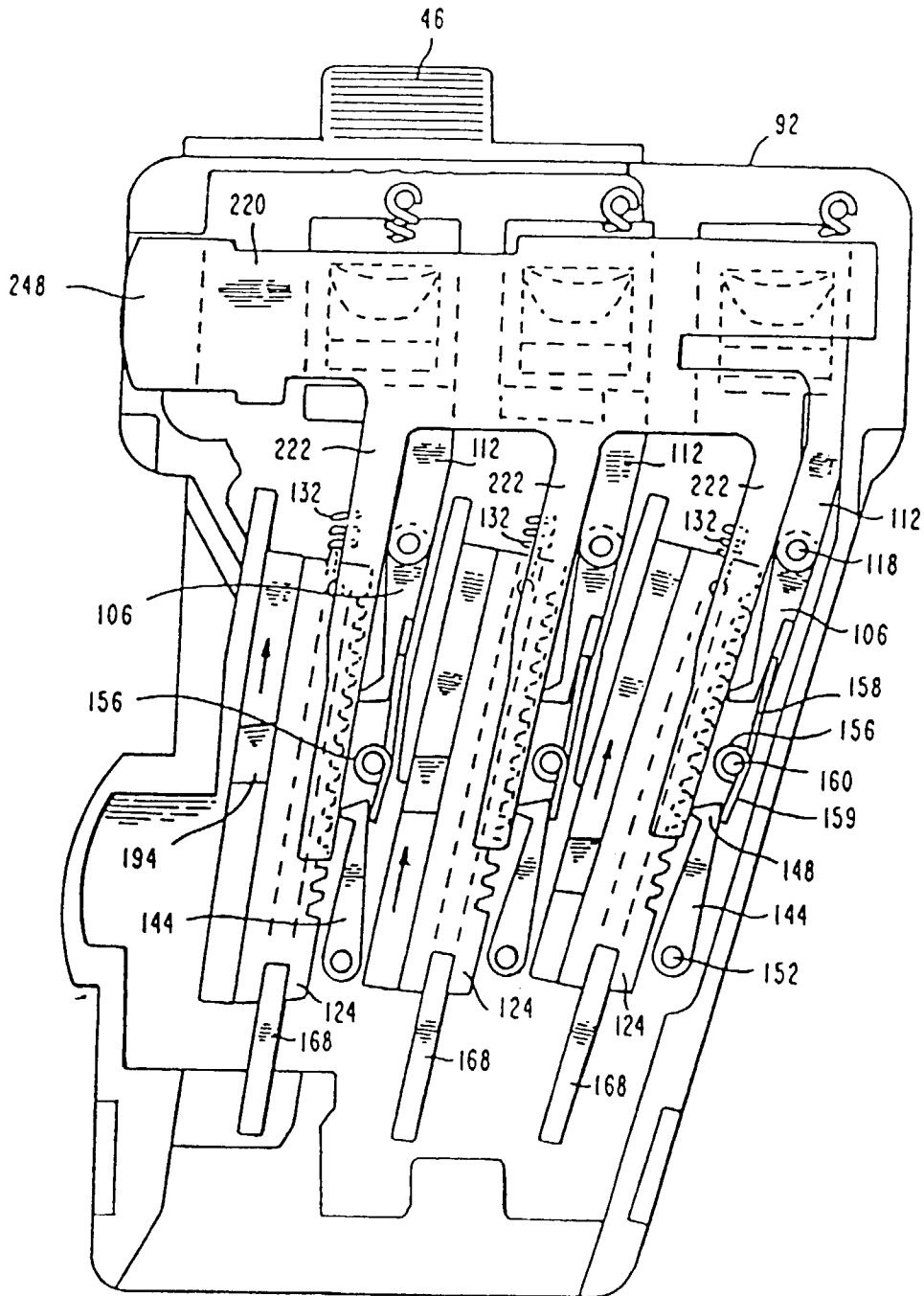

FIG. 7



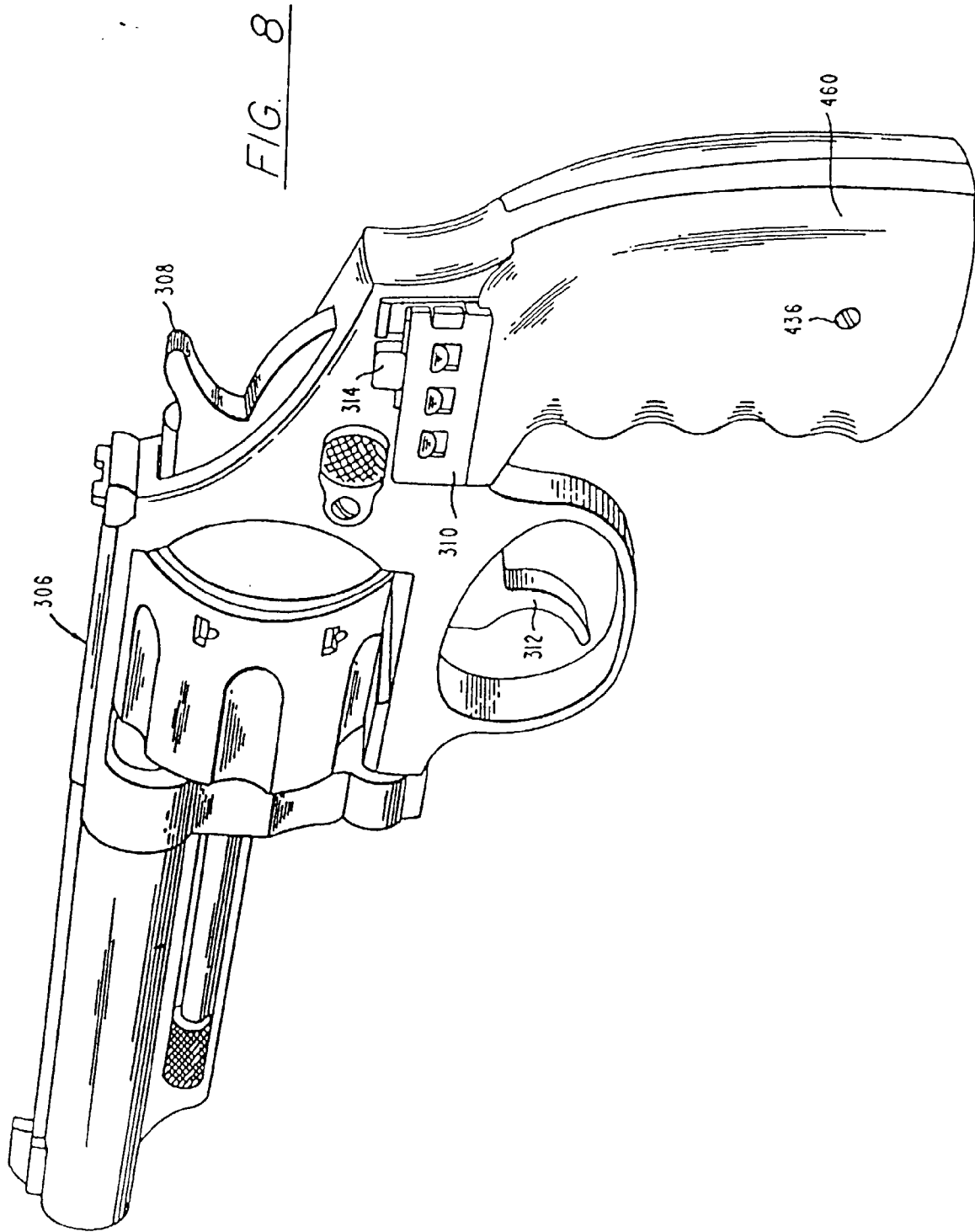
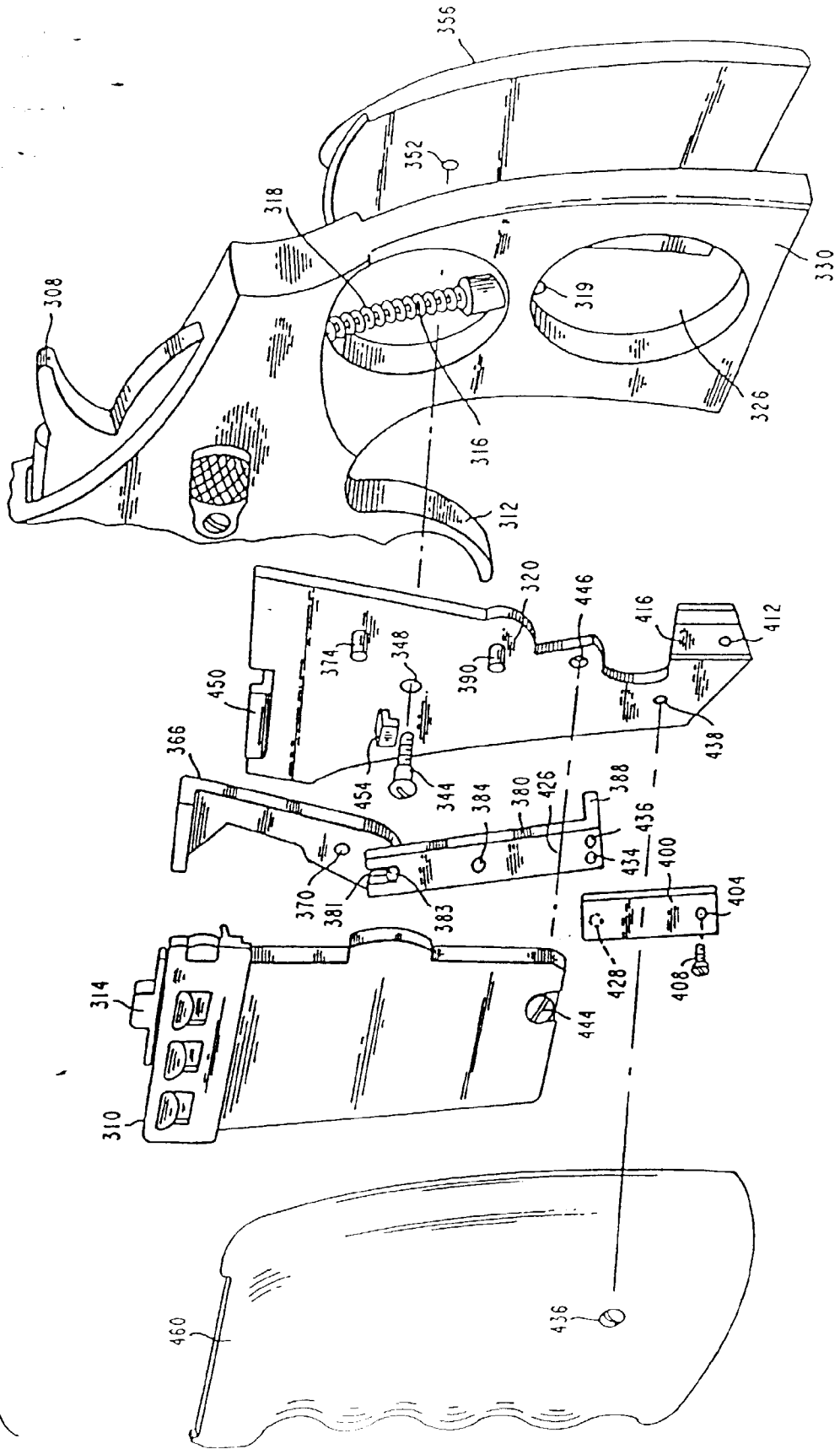

FIG. 9



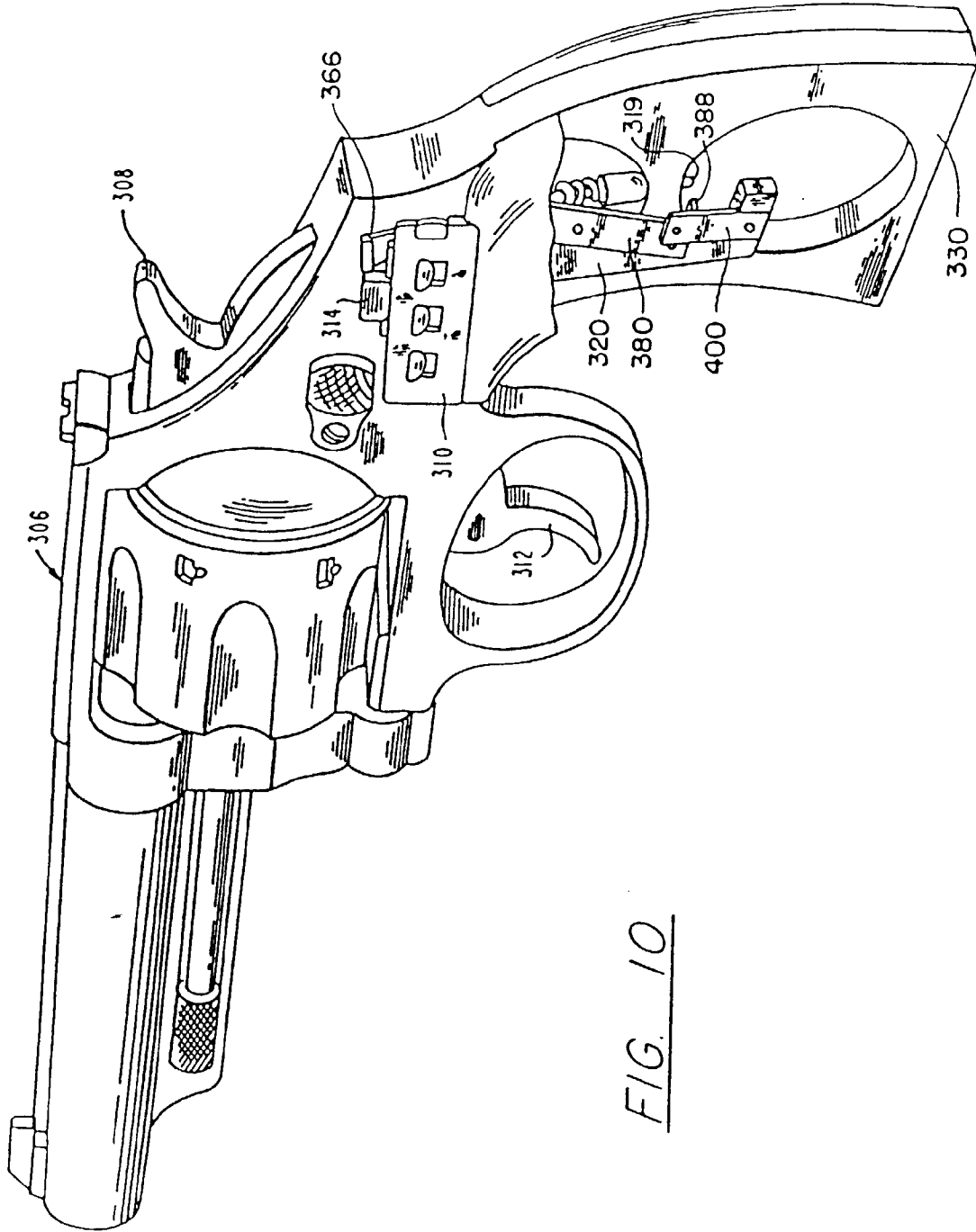

FIG. 10

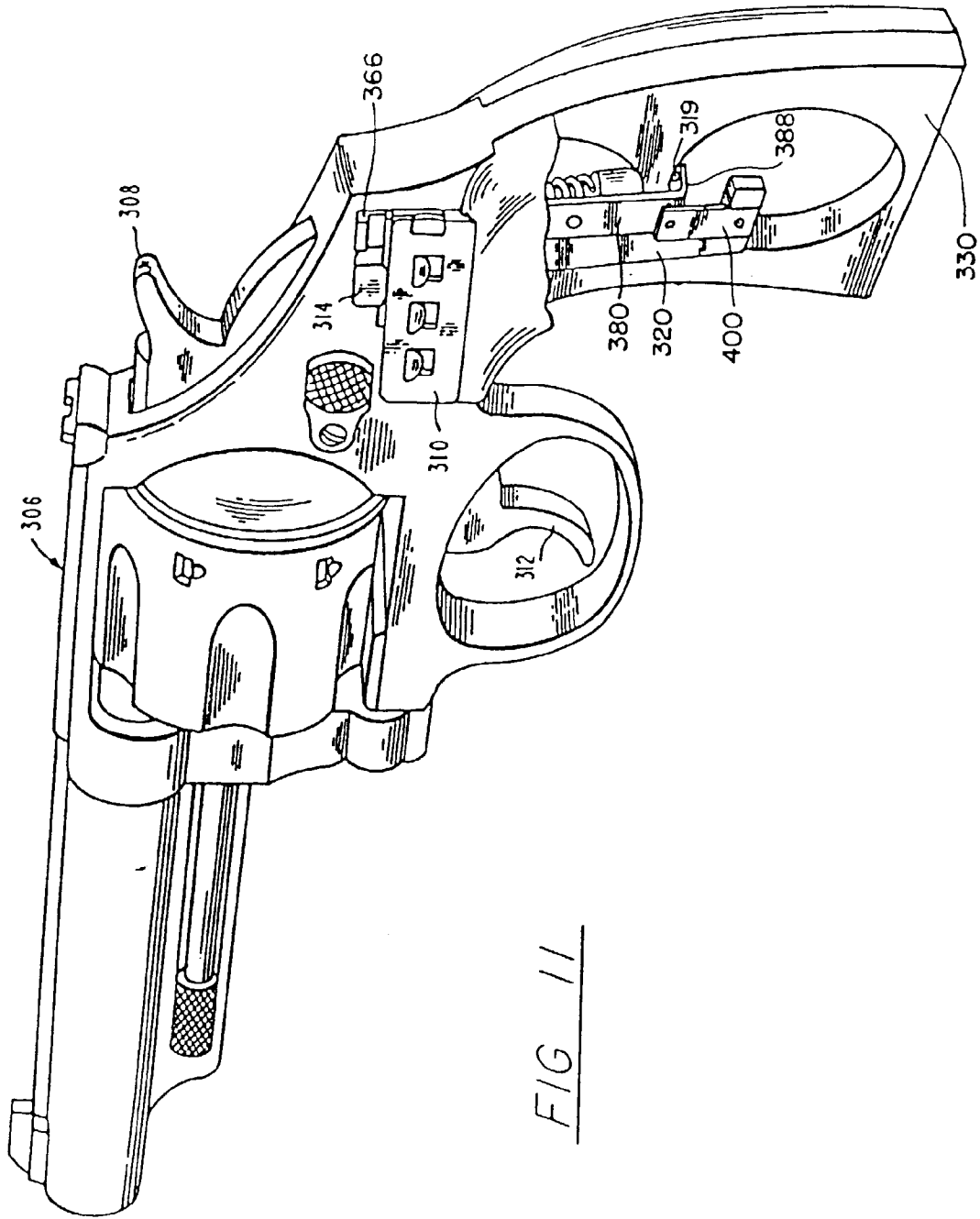

FIG 11

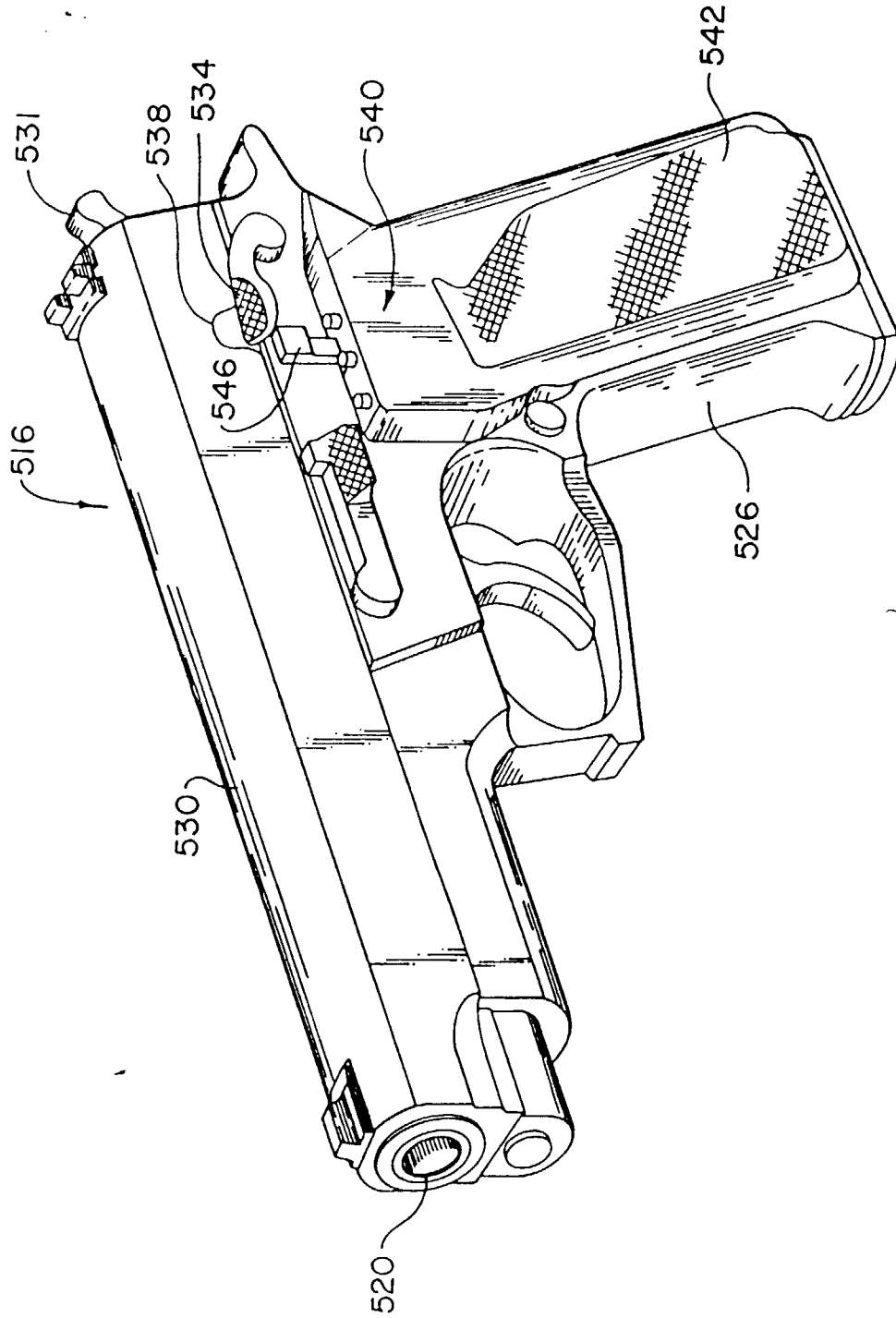

FIG. 12

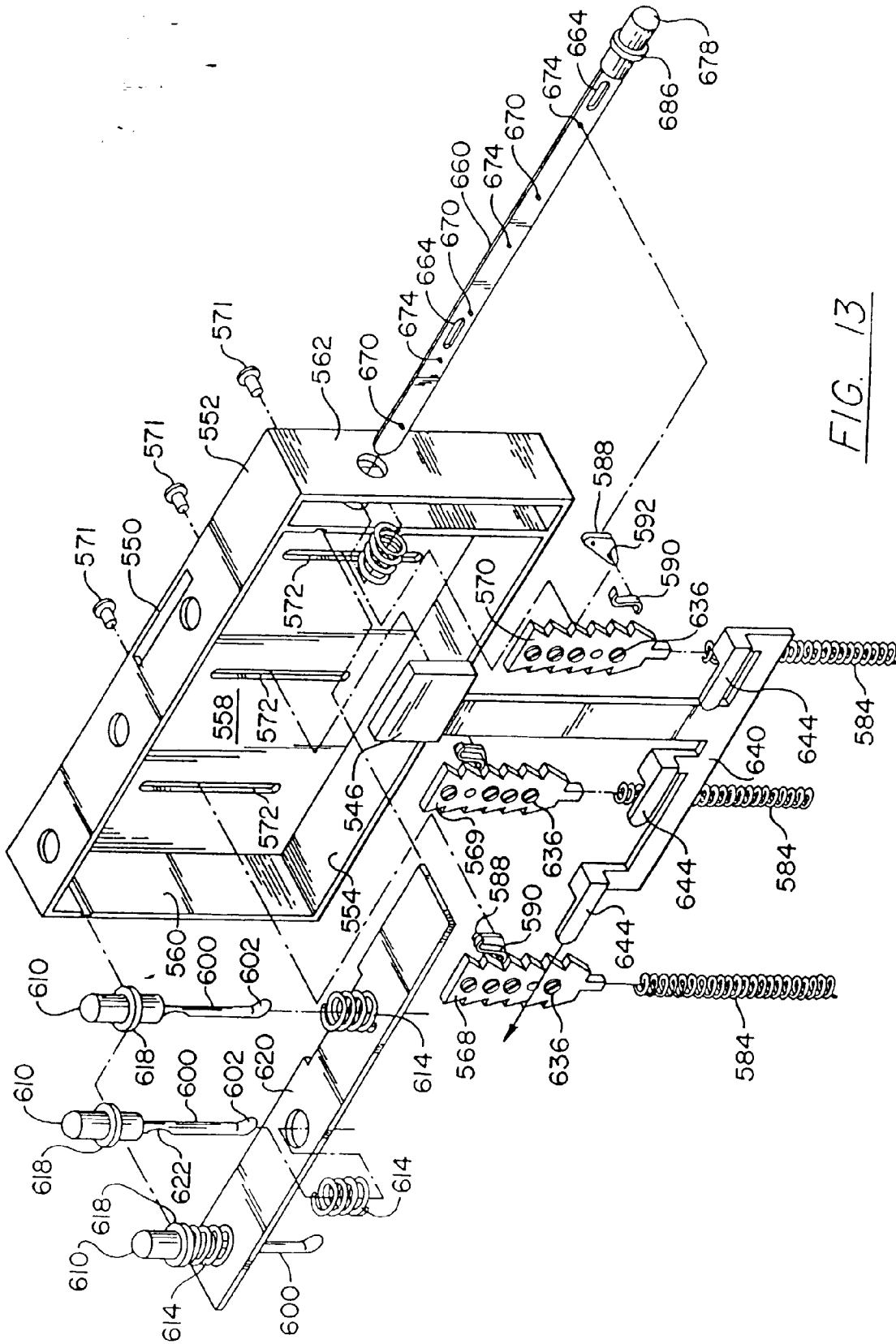

FIG. 13

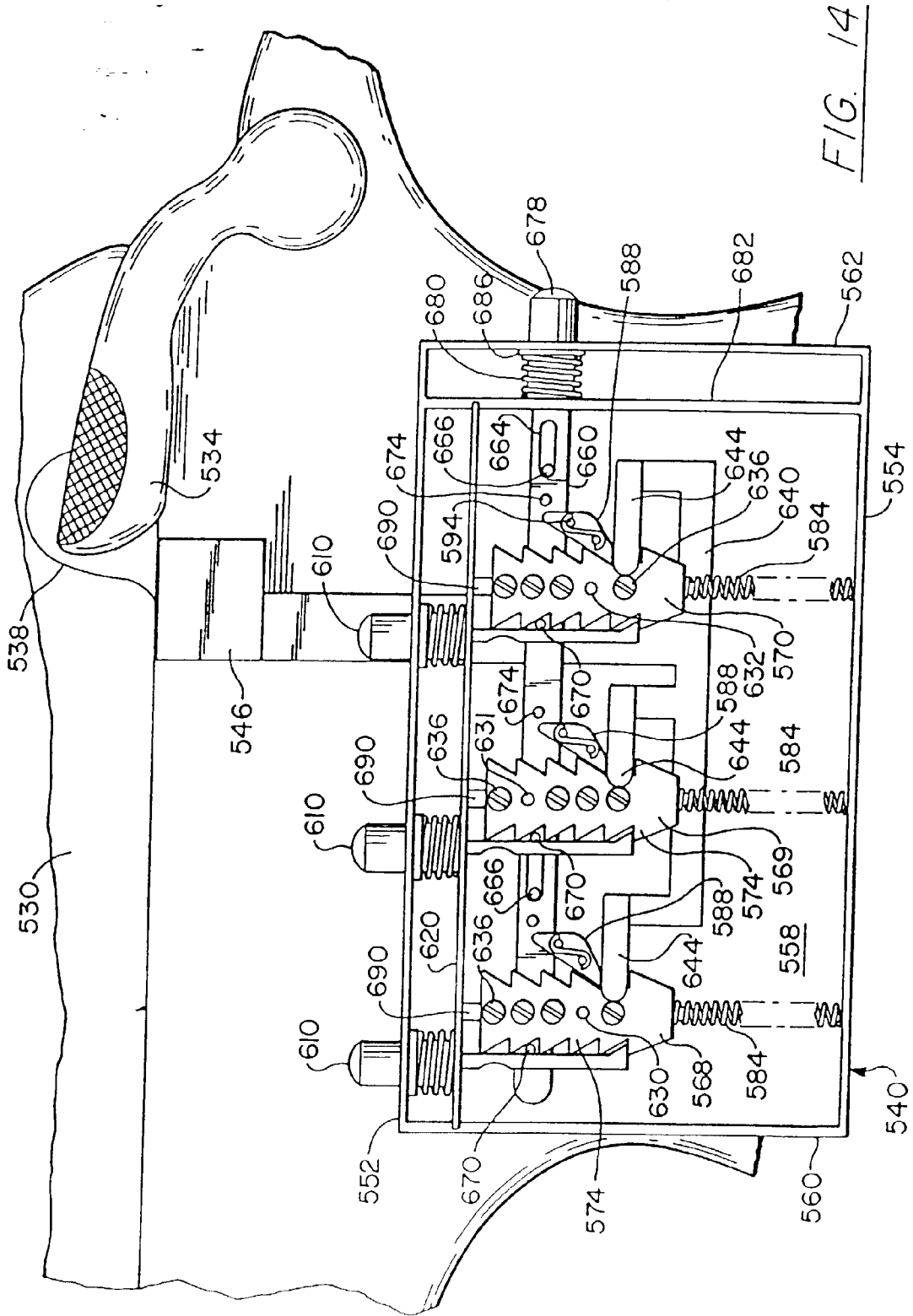

FIG. 14

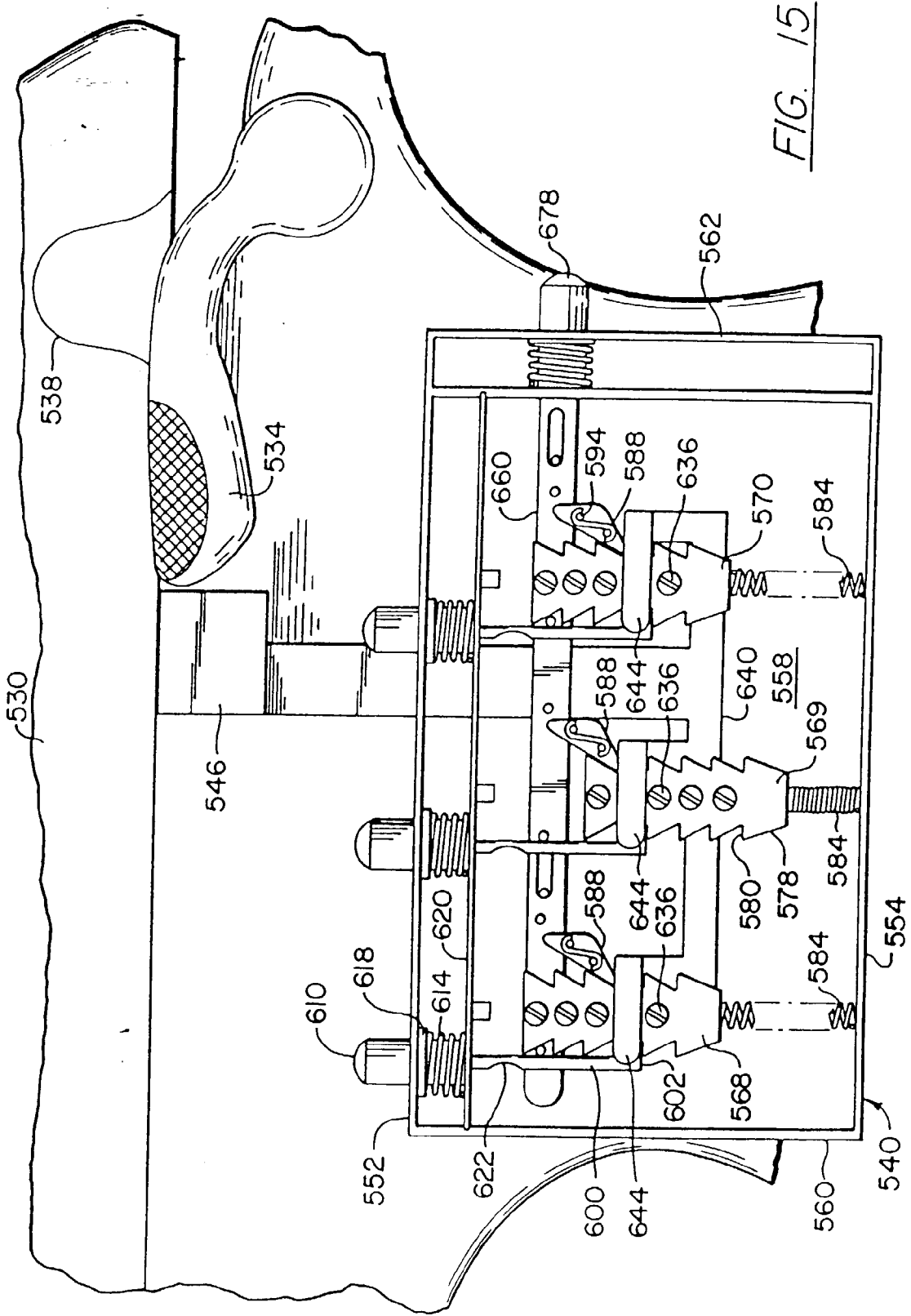

FIG. 15

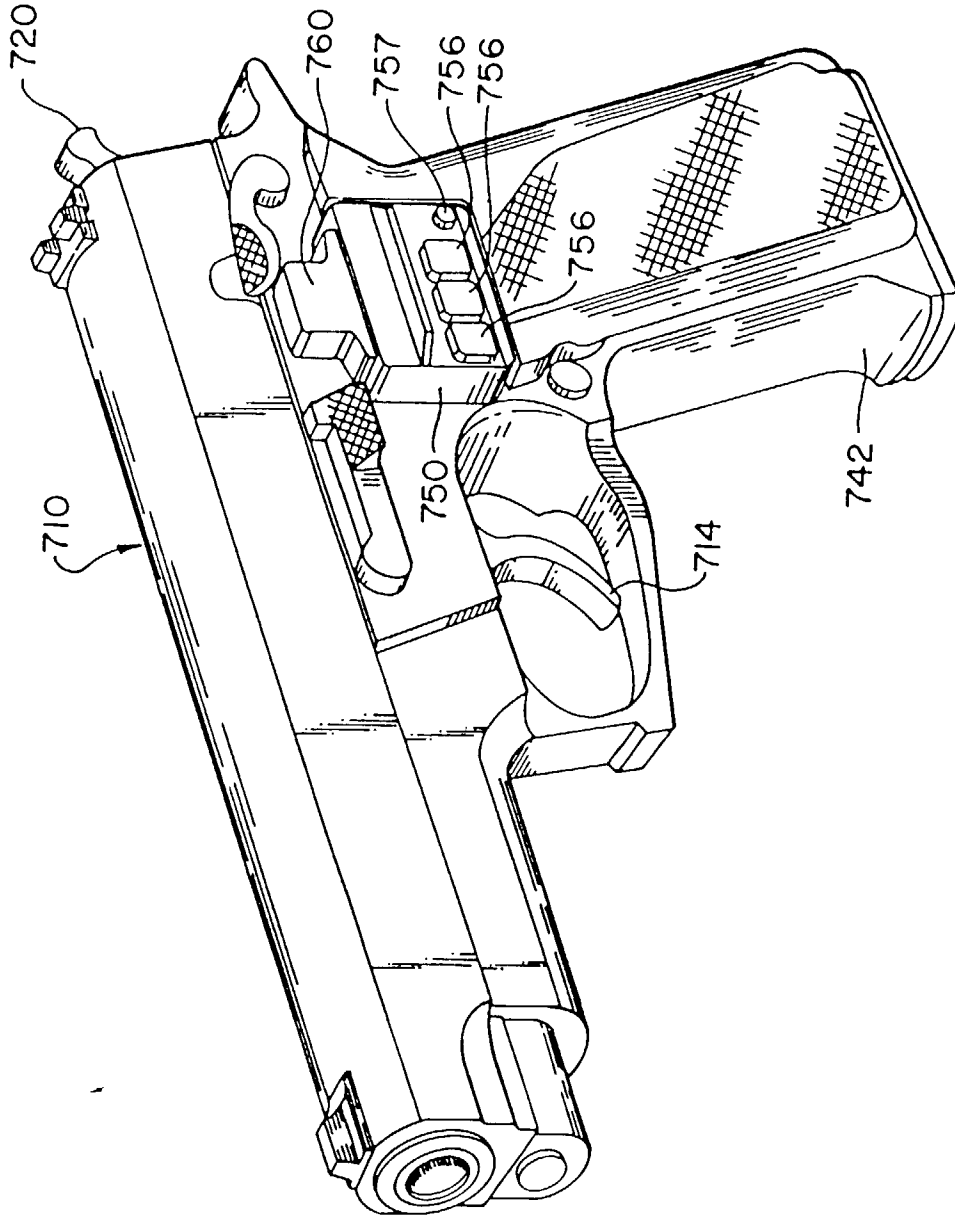

FIG. 16

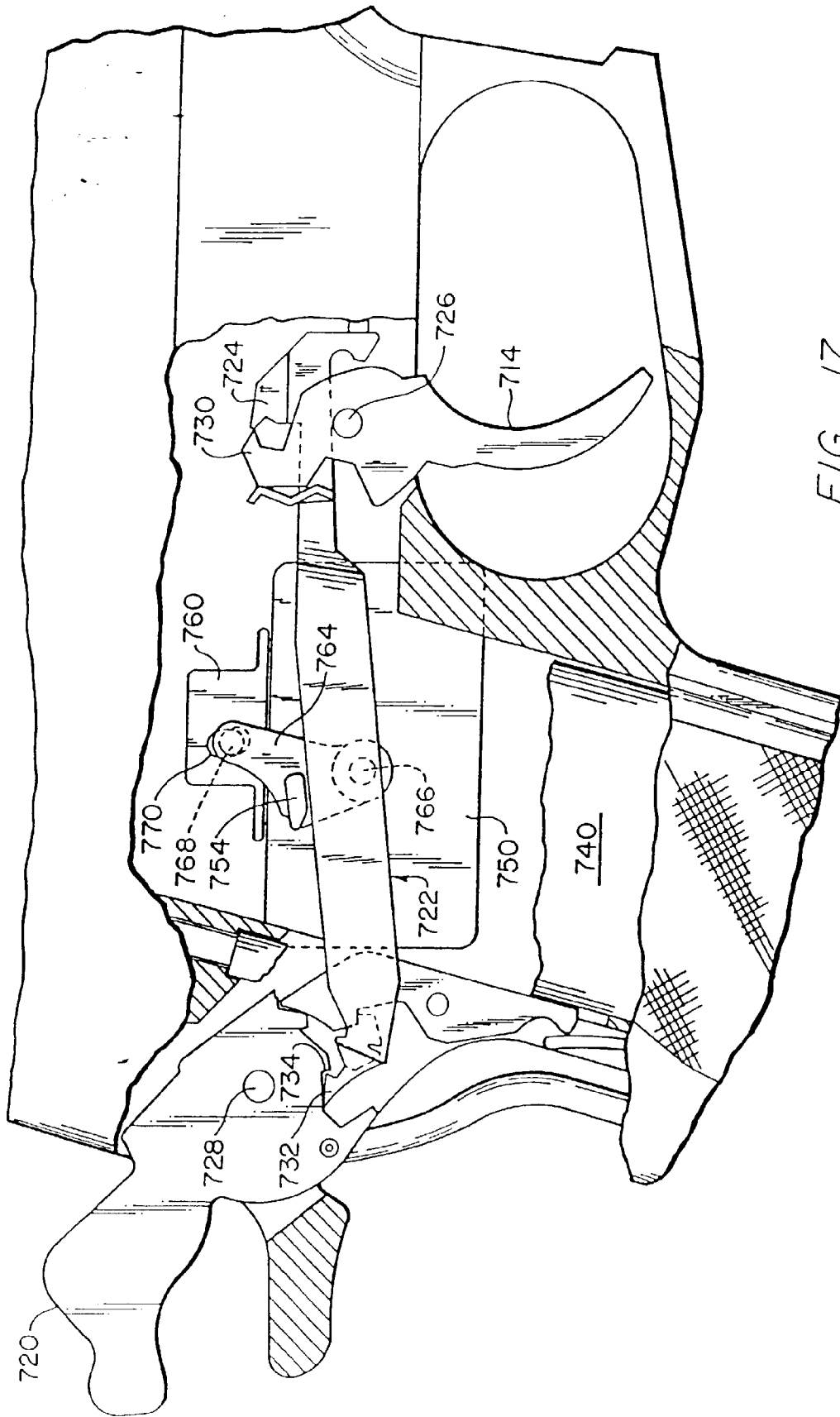

FIG. 17

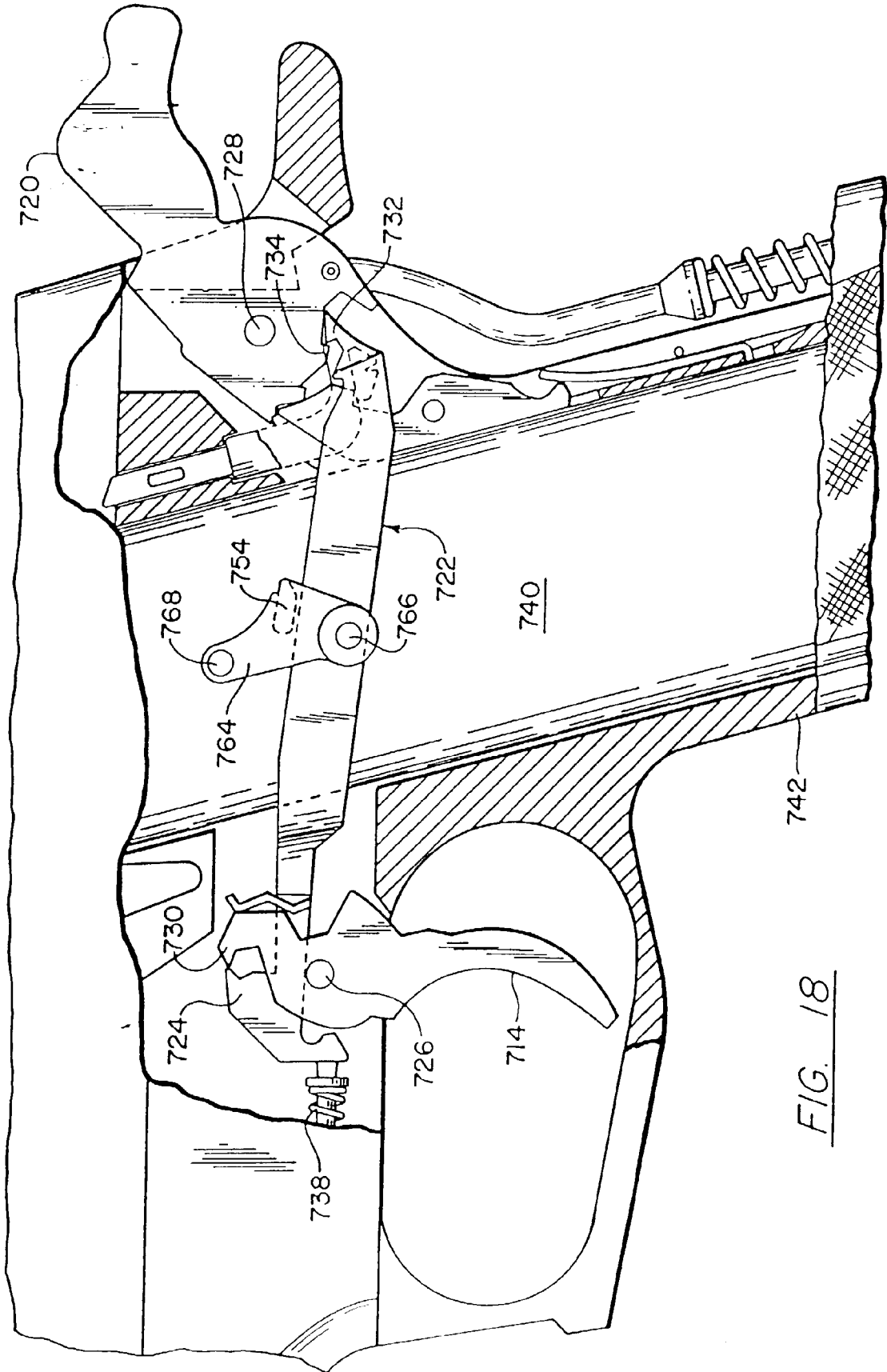

FIG. 18

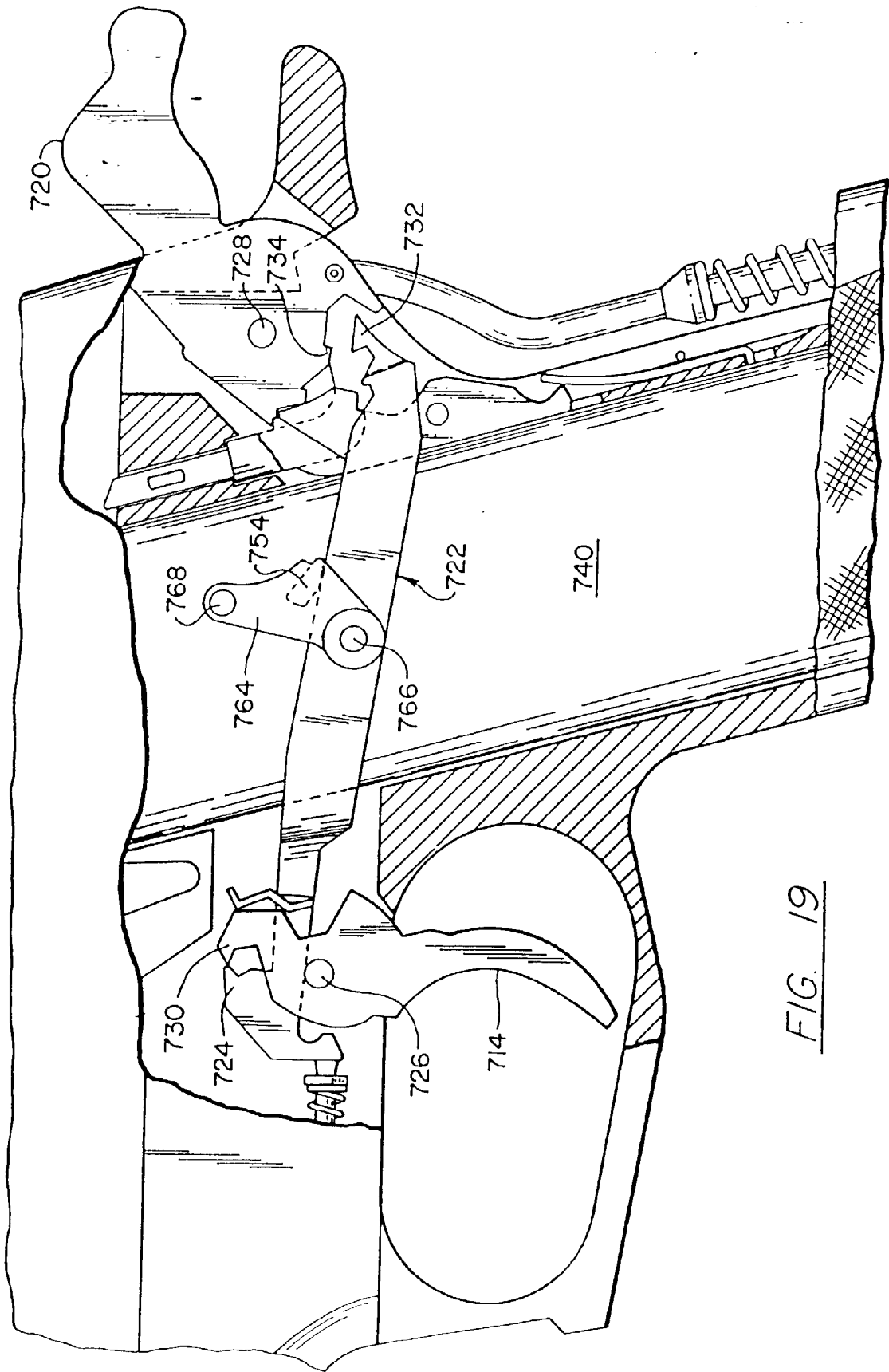

FIG. 19