

(No Model.)

E. J. McEVOY.
CIRCUIT CONTROLLER.

No. 524,808.

Patented Aug. 21, 1894.

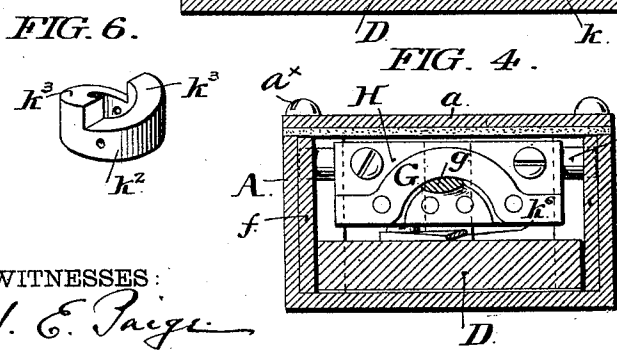
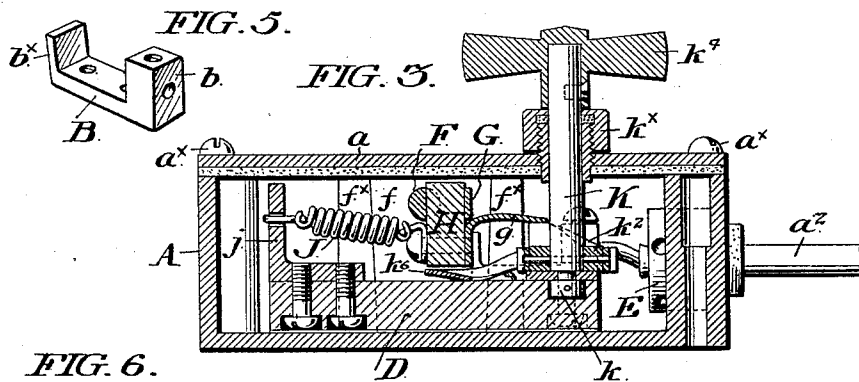
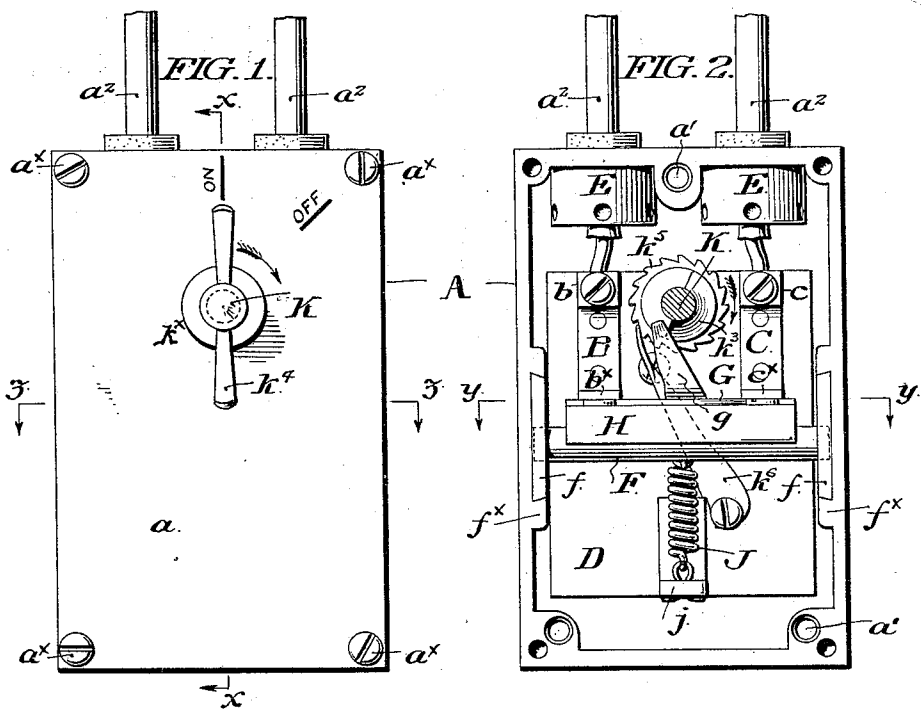

WITNESSES:
A. E. Paige
J. Norman Dixon

E. J. McEvoy
 INVENTOR
By his attorney
Wm. C. Strawbridge
Samuel Taylor

UNITED STATES PATENT OFFICE.

EDWARD J. McEVOY, OF NEW YORK, N. Y.

CIRCUIT-CONTROLLER.

SPECIFICATION forming part of Letters Patent No. 524,808, dated August 21, 1894.

Application filed July 7, 1894. Serial No. 516,827. (No model.)

To all whom it may concern:

Be it known that I, EDWARD J. McEVOY, a citizen of the United States, residing in the city, county, and State of New York, have invented certain new and useful Improvements in Circuit-Controllers, of which the following is a specification.

My invention relates to a class of devices designed to be included within an electric circuit and adapted to be operated to occasion the opening or closing of said circuit at will.

It is the object of my invention to provide a circuit-controller of a simple, durable, inexpensive, and efficient, character, which can be operated manually from the exterior of its casing.

My present invention embodies certain features of construction appertaining to a circuit-controller heretofore invented by me and patented to me in and by United States Letters Patent No. 514,019, dated February 6, 1894, to which reference is to be made.

In the drawings I show, and herein I describe, a preferred form of a good embodiment of my invention, the particular subject-matter claimed as novel being hereinafter definitely specified.

In the drawings, Figure 1 is a top plan view of a circuit-controller embodying my improvements, with the cover of the casing in place. Fig. 2 is a similar view of the same with the cover removed to exhibit the construction and arrangement of the interior parts. Fig. 3 is a central, vertical, longitudinal, side, sectional, elevation, throughout the controller, section being supposed in the plane of the dotted line $x-x$ of Fig. 1, and sight being taken in the direction of the arrows applied to said line. Fig. 4 is a transverse, vertical, sectional elevation through the controller, section being supposed in planes of the dotted lines $y-y$ of Fig. 2 and $z-z$ of Fig. 1. Fig. 5 is a view in perspective of one of the terminals removed from the casing; and Fig. 6 is a similar view of the rotatable cam for occasioning the oscillatory movement of the yoke-provided shaft.

Similar letters of reference indicate corresponding parts.

In the drawings, A indicates the inclosing casing of the circuit-controller, shown as consisting of a rectangular water-tight box, pro-

vided with a lid, a , secured in place thereon in any preferred manner, as, for example, by the screws a^x . The body of the casing is well made when of the form shown in the drawings, in which it is illustrated as formed as a single integral casting, provided as to its walls with beads or portions of extra thickness in which are formed counter-sunk holes a' for the reception of screws by which the casing may be secured to any desired support.

The line wires a^2 of the electric circuit in which the controller is placed are to be conducted through openings in one end of the casing, into, and placed in circuit with, binding posts $b c$, which form parts of terminals B C, mounted upon a block of insulating material D secured in position upon the floor of the casing.

Collars or thimbles E are applied to the inner face of the end wall of the casing, through openings in which the wires extend, the collars serving to support suitable packing material about the wires to prevent the entrance of moisture.

The terminals B C consist of a pair of counterpart plates secured, preferably in parallelism with each other, upon the surface of the insulating block D, in the outer ends of which the respective binding posts $b c$ hereinbefore mentioned are conveniently respectively formed or mounted, and the inner ends of which plates extend inward to a point in adjacency to the longitudinal center of the casing, and are conveniently provided with up-turned heels $C^x c^x$.

F is a rotatable rock shaft extending transversely and horizontally with respect to the casing, and conveniently journaled at its extremities in journal blocks or plates f adapted to be vertically inserted within dove-tailed ways f^x , formed in or applied to the inside side faces of the side walls of the casing. This construction permits of the easy application and removal of the shaft.

G is a yoke of conducting material carried by the shaft F, the respective extremities of which yoke are adapted to be moved into simultaneous contact with the inner extremities or heels of the respective terminals. In the drawings (the said shaft being supposed formed, as it may in fact most conveniently be formed, of conducting material), the said

yoke is shown as secured to the shaft through the interposition of a yoke carrier being a block of insulating material H, to which the yoke is secured by screws, and which block H is in turn secured by screws to the shaft. This is simply a preferred construction. As will be understood, upon the slight rotation of the shaft F in one direction (to the left, Fig. 3), the yoke will be carried out of contact with the terminals and the circuit thereby opened; while, upon the other hand, upon the slight rotation of the shaft F in the opposite direction, the yoke will be carried into contact with the terminals and the circuit thereby closed, as shown in said Fig. 3.

J is a spiral pull spring, which is shown as secured as to one end to the yoke-carrying block H, and as to the other to a small anchor plate *j* mounted upon the base block D,—the operation of which spring is, of course, to draw the block H constantly toward the said anchor plate, and, therefore, to hold the yoke G normally, that is to say, without regard to its control by the cam toe and cam hereinafter described, out of contact with the terminals B C.

K is a rotatable operating shaft, vertically erected within the casing conveniently at a point between the terminals, suitably insulated, and stepped into the base block conveniently by means of the screw step *k*, which, however, is not essential, as a simple socket or cone bearing will answer the purpose. The shaft passes vertically upward through a water-tight stuffing box *k^x* in the cover of the casing, and projects therefrom. Near its lower portion and within the casing the operating shaft is formed or provided with a rotatable cylindrical cam *k²*, Fig. 6, the upper face of which is provided with two correspondingly disposed, counterpart, opposite, cam faces or inclines *k³*, upon one or the other of which a cam toe *g*, springing rigidly from the shaft or yoke carrier of the shaft, is always treading,—and which, in the rotation of the shaft, which is always in the direction of the segmental arrows of Figs. 1 and 2, is caused to travel from the base or hollow to the crest of a given cam face, and then to drop from said crest to the base of the succeeding cam face to the crest of which it again, in the further rotation of the cam, rises. The cam toe being, as explained, applied to the shaft, will, in its travel over a cam face, occasion the gradual tilt of the shaft, yoke-carrier, and yoke, with the result, the proportions and relationship of the parts being appropriate, that when the cam toe has reached the crest of a cam face, the shaft will have been so tilted,—to the right in Fig. 3,—as to have brought the yoke into contact with the heels of the terminals to complete the circuit through the controller. When, therefore, the parts are in the foregoing position, if the shaft be permitted to dwell, the circuit will be maintained closed. When, upon the other hand, the shaft is suf-

ficiently further rotated to permit of the drop of the cam toe from the crest of a particular cam face to the base of the succeeding cam face, the pull spring will operate to tilt the shaft and its yoke in the reverse direction and away from the terminals so as to open the circuit.

The position of the parts within the casing may be indicated from the outside of the casing by applying an indicating handle *k¹* to the protruding portion of the operating shaft, and by further applying to the cover of the casing indicating words, such, for instance, as "on" or "off," or "open" or "closed."

In order to prevent possible slipping of the operating shaft, I apply to it, conveniently at the base of the cam, a circular ratchet *k⁵* against the teeth of which a spring pawl *k⁶*, springing conveniently from the base block of the casing, exerts a constant pressure.

The mere detail of the construction of the device is not of the essence of the invention, and may be varied at the will of the constructor. The construction represented is, however, a convenient one.

Having thus described my invention, I claim—

1. The combination to form a circuit-controller,—of a box or casing,—a pair of terminals provided with binding posts,—a rotatable rock shaft mounted in said box or casing,—a yoke of conducting material carried by said shaft,—a spring the operation of which is to hold the yoke out of contact with the terminals,—an operating shaft journaled within the casing and projecting therefrom,—a cam upon and rotating with said operating shaft,—and a cam toe springing from the rock shaft and bearing upon the cam,—substantially as set forth.

2. The combination to form a circuit-controller,—of a box or casing,—a pair of terminals provided with binding posts,—a rotatable rock shaft mounted in said box or casing,—a yoke of conducting material carried by said shaft,—a spring the operation of which is to hold the yoke out of contact with the terminals,—an operating shaft journaled within the casing and projecting therefrom,—a cam upon and rotating with said operating shaft,—a cam toe springing from the rock shaft and bearing upon the cam,—and an indicating handle upon the projecting portion of the operating shaft,—substantially as set forth.

3. The combination to form a circuit controller,—of a box or casing,—a pair of terminals provided with binding posts,—a rotatable rock shaft mounted in said box or casing,—a yoke of conducting material carried by said shaft,—a spring the operation of which is to hold the yoke out of contact with the terminals,—an operating shaft journaled within the casing and projecting therefrom,—a cam upon and rotating with said operating shaft,—a cam toe springing from the rock shaft and bearing upon the cam,—a ratchet upon the

operating shaft,—and a spring pawl within the casing in constant engagement with said ratchet, substantially as set forth.

4. The combination to form a circuit-controller,—of a box or casing,—a pair of terminals provided with binding posts,—a rotatable rock shaft mounted in said box or casing,—a yoke of conducting material carried by said shaft,—a spring the operation of which is to hold the yoke out of contact with the terminals,—an operating shaft journaled within the casing and projecting therefrom,—a cam upon and rotating with said operating shaft,—a cam toe springing from the rock shaft, and

bearing upon the cam,—an indicating handle 15 upon the projecting portion of the operating shaft,—a ratchet upon the operating shaft,—and a spring pawl within the casing in constant engagement with said ratchet,—substantially as set forth. 20

In testimony that I claim the foregoing as my invention I have hereunto signed my name this 2d day of July, 1894.

EDWARD J. McEVOY.

In presence of—

J. BONSALE TAYLOR,
F. NORMAN DIXON.