

(No Model.)

W. S. McCAY & L. V. MOULTON.
SECTIONAL FEED ROLL.

No. 523,290.

Patented July 17, 1894.

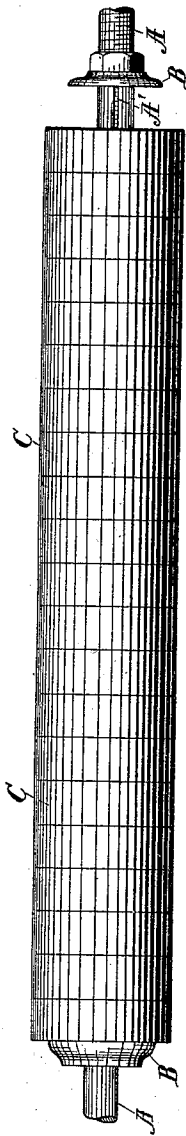

Fig. 1.

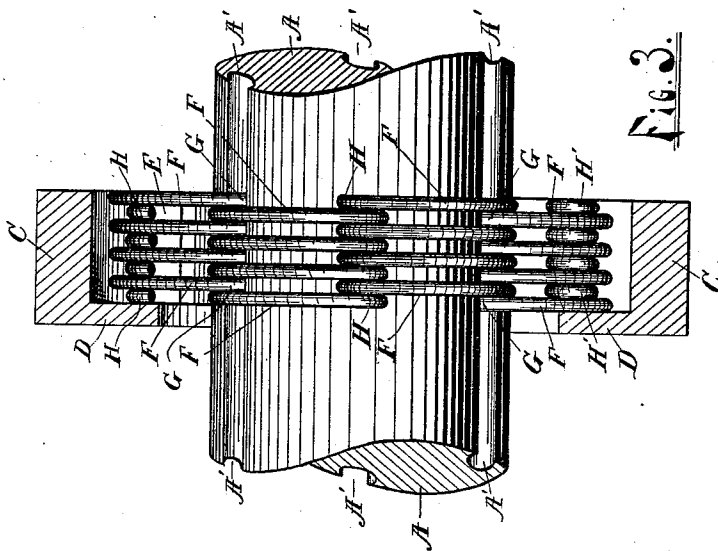

Fig. 3.

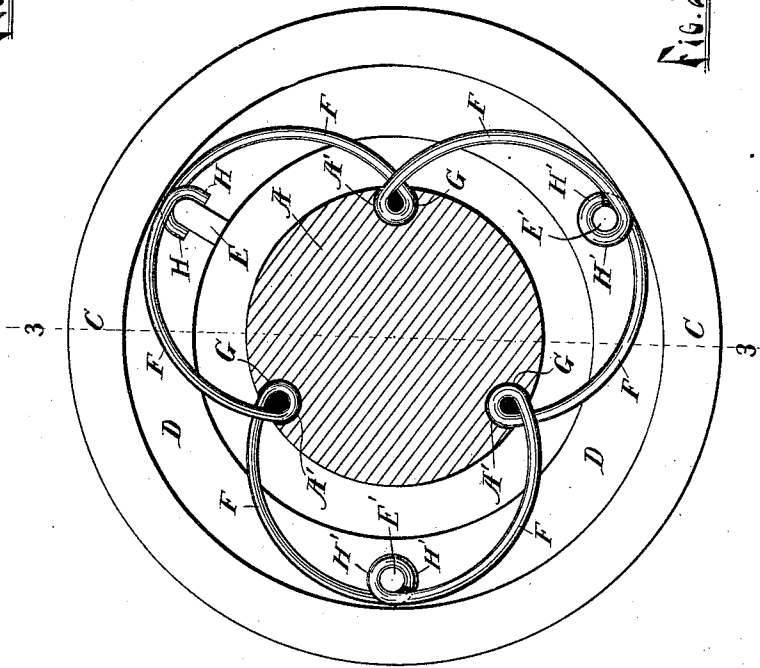

Fig. 2.

WITNESSES:

Levi C. Standen
Lois Moulton

INVENTOR:

William S. McCay
Luther V. Moulton

BY

Luther V. Moulton
ATTORNEY.

UNITED STATES PATENT OFFICE.

WILLIAM S. McCAY AND LUTHER V. MOULTON, OF GRAND RAPIDS,
MICHIGAN; SAID MOULTON ASSIGNOR TO SAID McCAY.

SECTIONAL FEED-ROLL.

SPECIFICATION forming part of Letters Patent No. 523,290, dated July 17, 1894.

Application filed June 2, 1893. Serial No. 476,391. (No model.)

To all whom it may concern:

Be it known that we, WILLIAM S. McCAY and LUTHER V. MOULTON, citizens of the United States, residing at Grand Rapids, in the county of Kent and State of Michigan, have invented certain new and useful Improvements in Sectional Feed-Rolls; and we do hereby declare the following to be a full, clear, and exact description of the invention, such as will enable others skilled in the art to which it appertains to make and use the same.

Our invention relates to improvements in sectional feed rolls for wood working machines, and its object is to provide the same with certain new and useful features, hereinafter more fully described and particularly pointed out in the claims, reference being had to the accompanying drawings, in which—

Figure 1 is a side view of the roll with one section removed; Fig. 2 a full size end view of one section of the roll and a broken portion of the shaft; and Fig. 3 a side view of the same, with the roll in section on the line 3—3 of Fig. 2.

Like letters refer to like parts in all of the figures.

A is a shaft in which are three equi-distant longitudinal grooves A' concave in cross section, each having converging acute angles at each side, whereby the opening in the surface of the shaft is less than the axial diameter of the groove.

B, B, are collars at each side of the roll sections to keep them in place. Said sections consist of a series of short hollow cylinders C, having integral heads D at one end, each head having a central opening considerably larger than the shaft, whereby said section is laterally movable about the axis of the same to the extent of the flexibility of the springs. Said springs connect said sections to the shaft and consist of a series of spring wires, having a loop G at the middle of each, and oppositely extended curved tangential arms F, each having an eye H', at each end. The loop G has an outside diameter equal to the cross section of the groove A', whereby when inserted in said groove the spring is pivotally attached to the shaft.

The roll sections are each provided with

pins E', projecting from the inner face of the head D, with which the eyes H' are engaged. In lieu of the pins, lugs as at E may be provided, and hooks H formed on the end of the wires to engage the same, we prefer the pins and eyes, as less likely to permit the springs to slip under end pressure. The springs are thus attached at the middle to the shaft and at their ends to the roll section, thereby forming a flexible connection, which enables the shaft to rotate the roll sections, and enables each of said sections to independently yield to accommodate any variations in the thickness of stock under the various sections. Said springs are placed in position by inserting the loop at the middle of a spring in each of the grooves A', and turning said springs at right angles to the axis of the shaft, the hooks H or eyes H' will overlap each other at the adjacent ends of the springs all round. The springs are next inserted in the roll section and engaged with the pins E', or lugs E. By filling the roll section with springs in this manner, the springs engage and hold each other in place in each section, and the heads D engage each group of springs and retain them in the respective sections, said head also engages the shaft and limits the deflection of the springs, and prevents bending or breaking the same. The normal tendency of the spring brings the shaft in the axis of the roll sections, and the springs are deflected in either direction from the normal, as they come alternately between the shaft and stock, or at the opposite position, and in intermediate positions one arm of the spring is compressed and the other extended, the loop G serving as a pivot and equalizing the strain, and also preventing any undue strain at the point of attachment to the shaft. Said springs are thus all in action all of the time, thus securing more service with a given amount of material than in case of devices in which only a part of the springs are in action at one time.

What we claim is—

1. In a feed roll, a series of hollow cylindrical sections, having central openings, a shaft of less diameter than said openings and passing through the same, and a series of springs pivotally connected to the shaft and extended

in curved tangential lines from said shaft and attached at their outer ends to said sections, and forming the sole connection between the same and said shaft, substantially as described.

2. In a feed roll, in combination with a series of cylindrical roll sections, having central openings and a shaft of less diameter than said openings, and passing through the same, a series of springs pivotally attached at the middle to said shaft, and having oppositely extended curved tangential arms pivotally attached at their outer ends to said roll sections, substantially as described.

3. In combination with a feed roll, having hollow sections, having central openings and a shaft of less diameter than said openings and passing through the same, and having a series of grooves concave in cross section and having converging acute angles, a series of springs, having loops near the middle inserted in said grooves to pivotally attach said springs to said shaft and oppositely extended curved arms to said springs attached at their outer ends to said roll sections, substantially as described.

4. In a feed roll in combination with a

shaft and a series of hollow cylindrical sections, having heads with enlarged openings surrounding said shaft, pins projecting from said heads, and springs pivotally attached at the middle to said shaft, and eyes in the ends of said springs engaging said pins, substantially as described.

5. In a feed roll, a series of hollow cylindrical sections, heads at one end of each section, having central openings, pins projecting from said heads, a shaft of less diameter than said openings and within the same, a series of longitudinal grooves, concave in cross section and having converging acute angles at each side and a series of wire springs having loops at the middle engaging said grooves, and oppositely extended curved portions, terminating in eyes surrounding said pins, substantially as described.

In testimony whereof we affix our signatures in presence of two witnesses.

WILLIAM S. MCCAY.
LUTHER V. MOULTON.

Witnesses:

FRANK S. MADISON,
LEWIS E. FLANDERS,