

(No Model.)

6 Sheets—Sheet 1.

F. PEARCE & J. BROICH. DIAL TRANSMITTER.

No. 526,356.

Patented Sept. 18, 1894.

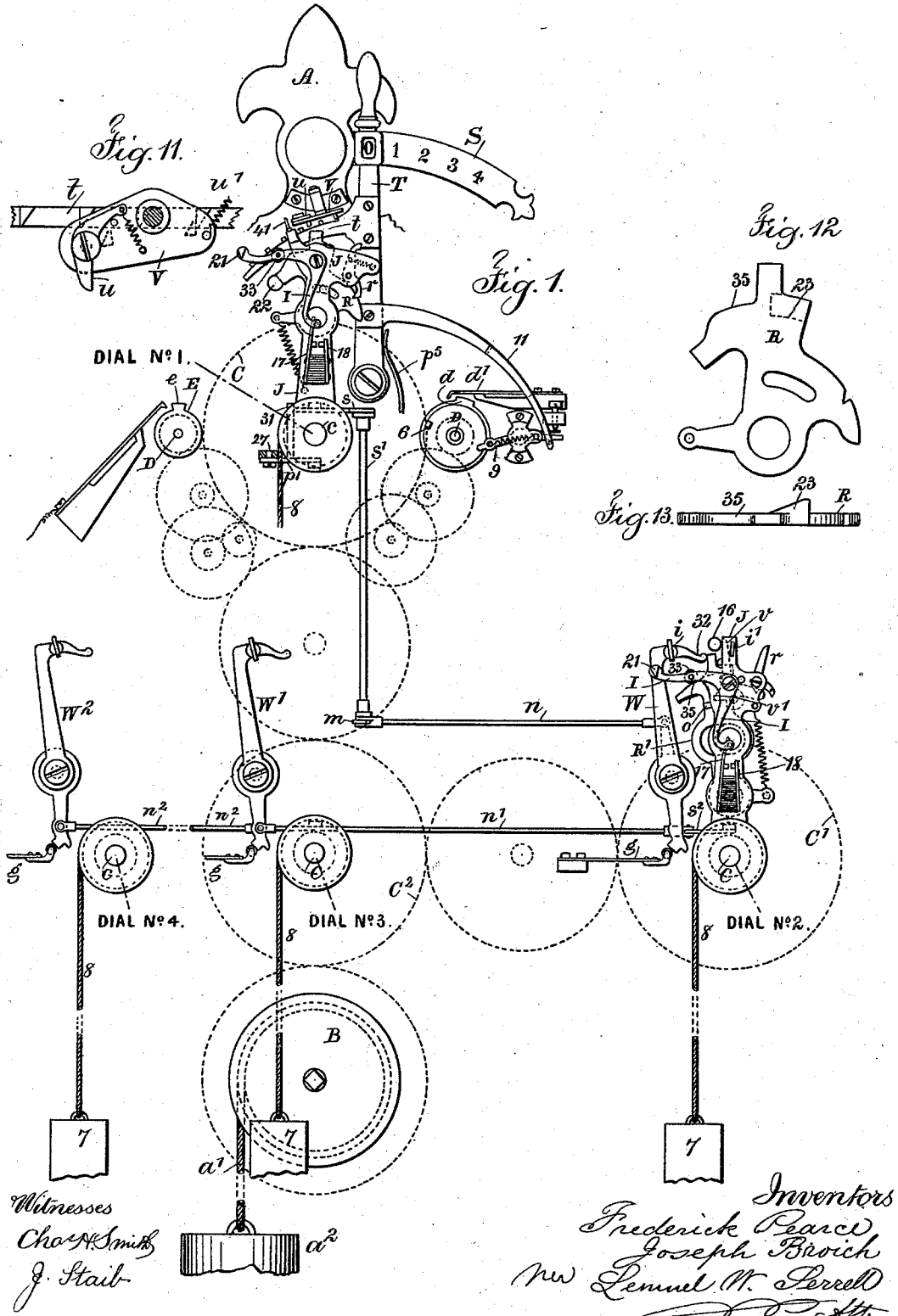

Witnesses
 Chas. A. Smith
 J. Stahl

Inventors
 Frederick Pearce
 Joseph Broich
 per Lemuel W. Perrell
 Atty

(No Model.)

6 Sheets—Sheet 2.

F. PEARCE & J. BROICH. DIAL TRANSMITTER.

No. 526,356.

Patented Sept. 18, 1894.

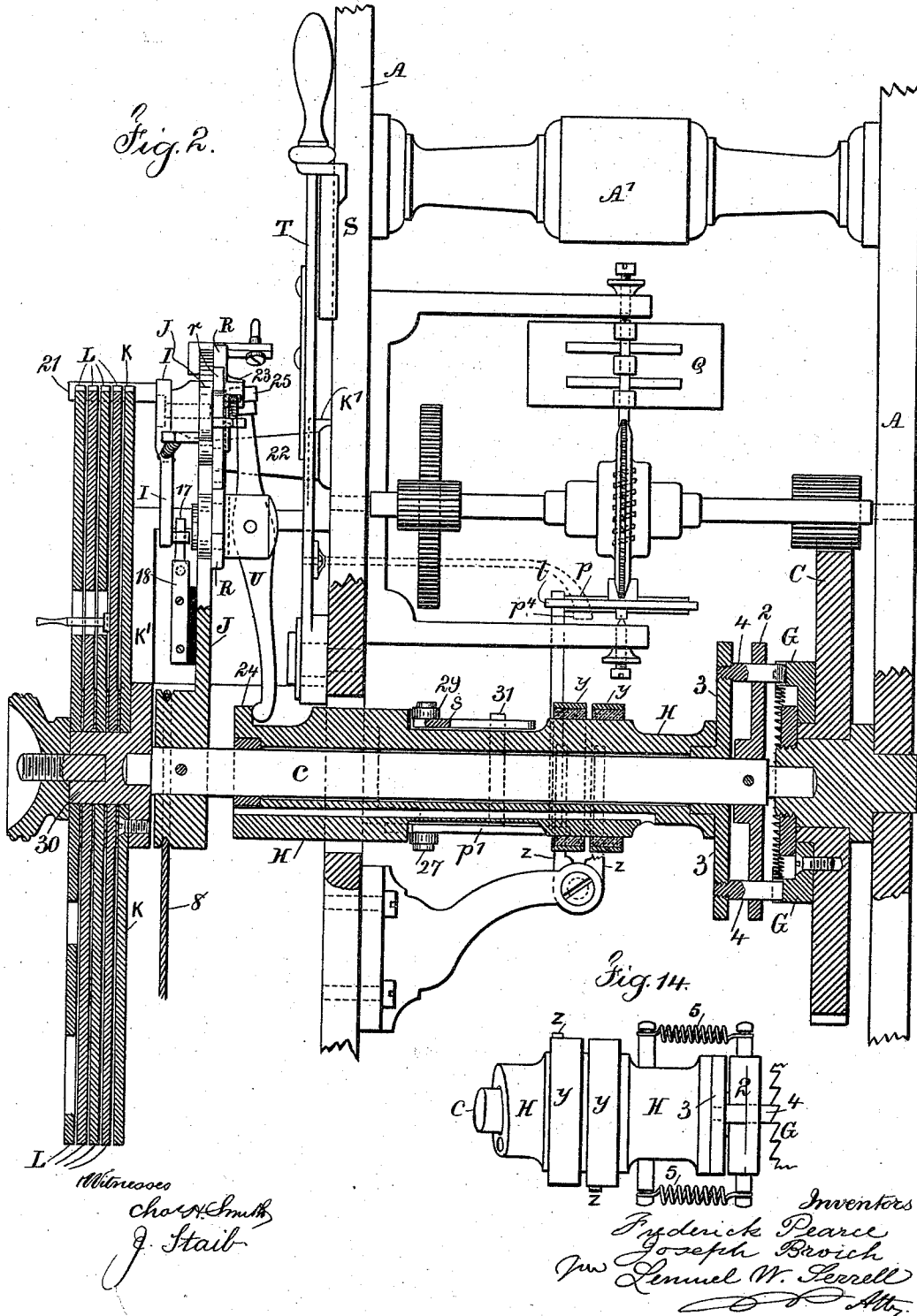

(No Model.)

6 Sheets—Sheet 3.

F. PEARCE & J. BROICH.
DIAL TRANSMITTER.

No. 526,356.

Patented Sept. 18, 1894.

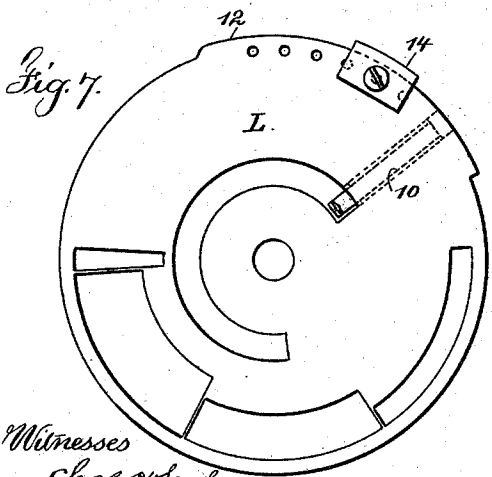
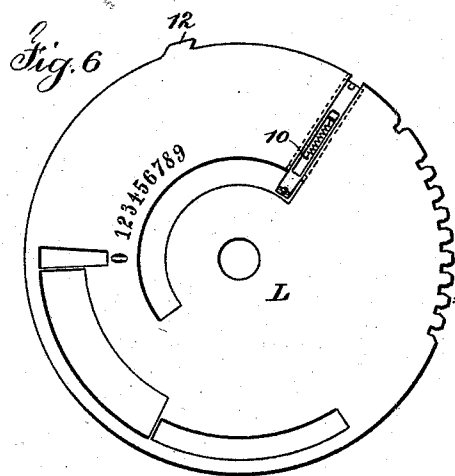
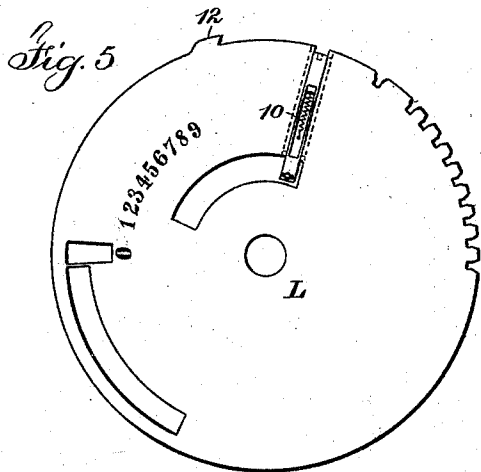
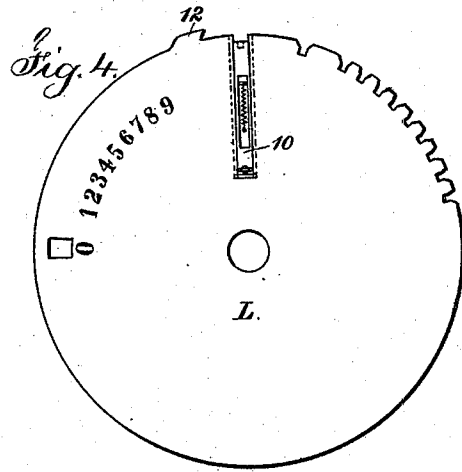
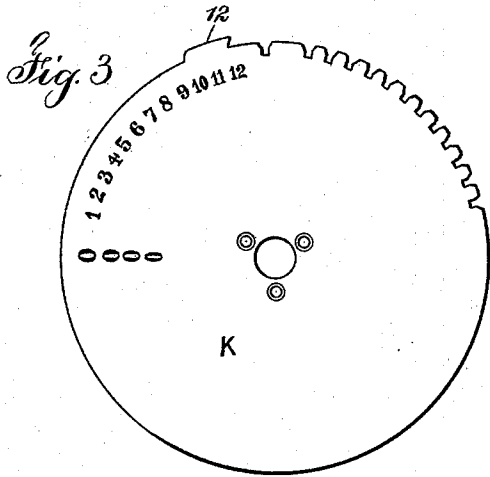

Witnesses
 Chas. H. Smith
 J. Stait

Inventors
 Frederick Pearce
 Joseph Broich
 per Lemuel W. Everett
 Atty.

(No Model.)

F. PEARCE & J. BROICH.
DIAL TRANSMITTER.

6 Sheets—Sheet 4.

No. 526,356.

Patented Sept. 18, 1894.

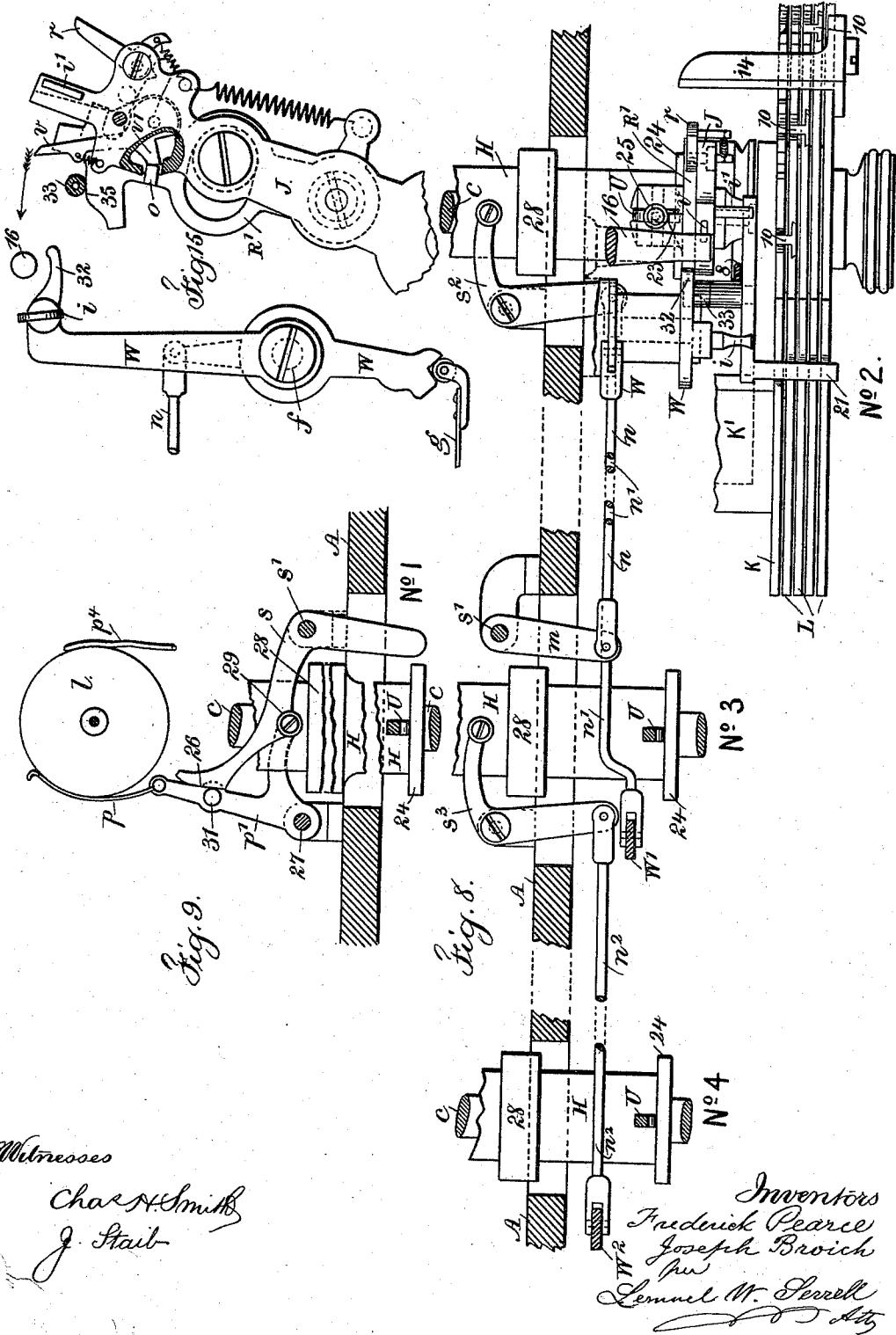

Witnesses
Char. A. Smith
J. Staub

Inventors
Frederick Pearce
Joseph Broich
per
Lemuel W. Serrell
Att'y

(No Model.)

6 Sheets—Sheet 5.

F. PEARCE & J. BROICH.
DIAL TRANSMITTER.

No. 526,356.

Patented Sept. 18, 1894

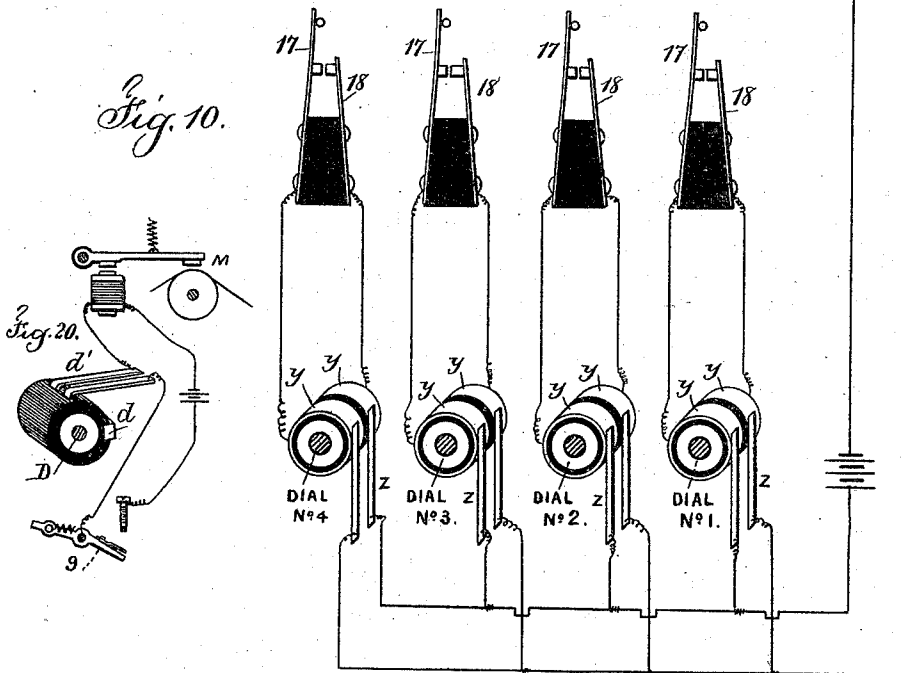
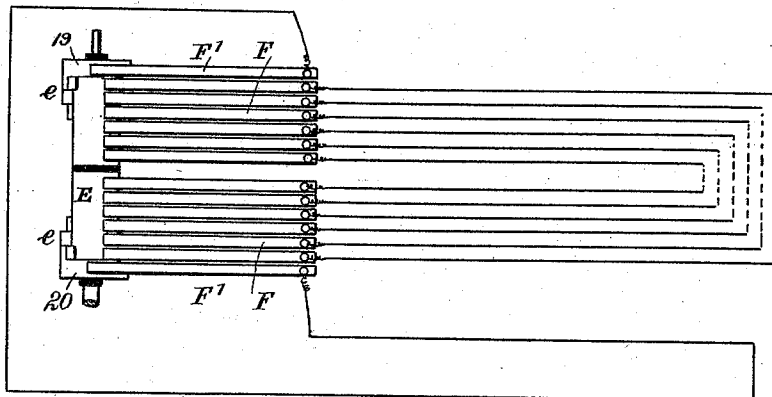

Witnesses
 Chas. N. Smith
 J. Strait

Inventors
 Frederick Pearce
 Joseph Broich
 per Lemuel W. Lovell
 Atty.

(No Model.)

6 Sheets—Sheet 6.

F. PEARCE & J. BROICH. DIAL TRANSMITTER.

No. 526,356.

Patented Sept. 18, 1894.

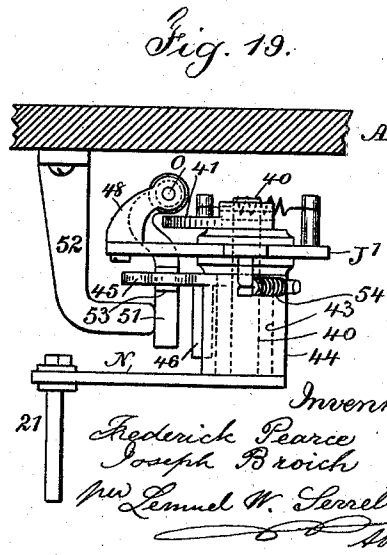
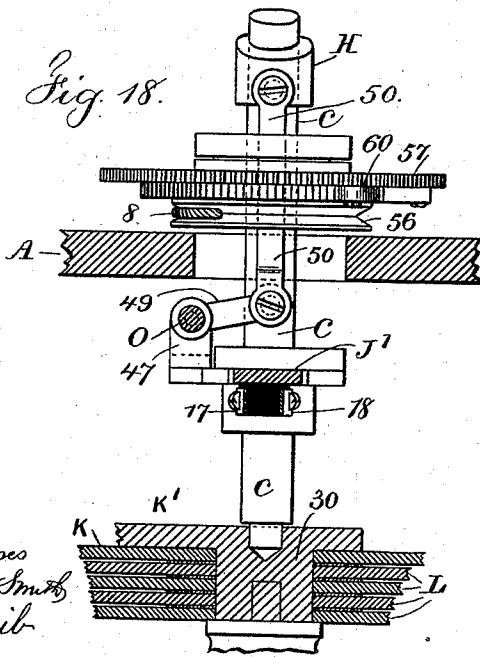
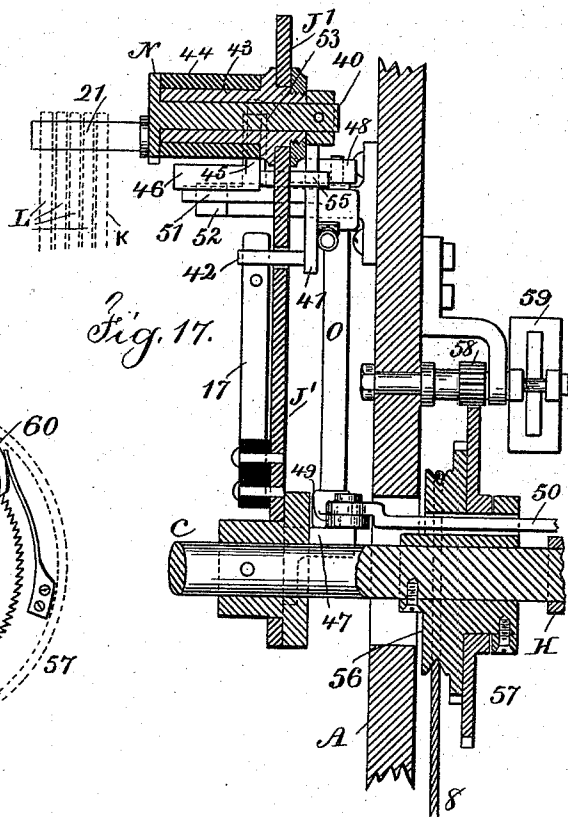
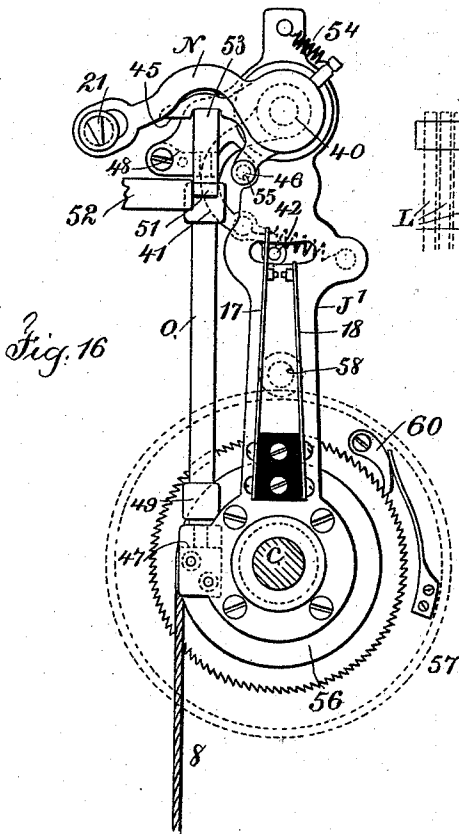

Witnesses
 Chas. A. Smith
 J. Strick

Inventors
 Frederick Pearce
 Joseph Broich
 per Lemuel W. Searell

UNITED STATES PATENT OFFICE.

FREDERICK PEARCE, OF NEW YORK, AND JOSEPH BROICH, OF BROOKLYN,
NEW YORK, ASSIGNORS TO SAID PEARCE.

DIAL TRANSMITTER.

SPECIFICATION forming part of Letters Patent No. 526,356, dated September 18, 1894.

Application filed June 11, 1894. Serial No. 514,165. (No model.)

To all whom it may concern:

Be it known that we, FREDERICK PEARCE, residing in the city, county, and State of New York, and JOSEPH BROICH, residing at Brooklyn, in the county of Kings and State of New York, both citizens of the United States, have invented an Improvement in Dial Transmitters, of which the following is a specification.

This instrument is a modification of and improvement upon the dial transmitter set forth in Letters Patent No. 482,877, granted September 20, 1892. In that instrument a single dial is represented together with the devices by which different numbers can be transmitted over various electric circuits for giving signals at numerous engine houses in connection with fire alarm telegraph systems.

It has been found advisable to provide two or more signals to be employed in rapid succession, one signal or set of numbers indicating in the code of signals a known requirement or call, such for instance as a hook and ladder, a water tower, fire engines within a certain district, or calls or commands of this general character, and another signal indicating the location of the fire or the place to which the certain things indicated are to proceed.

In our present invention we combine with a dial transmitter, which may be regarded as the main dial, one or more auxiliary dials, the parts being so constructed and arranged that the signals sent in by the one or more auxiliary dials precede the signals sent in by the main dial, and the auxiliary dials come into action automatically; that is to say, if two auxiliary dials are to be actuated, they are set, and the movement at the termination of the signal given by the first dial couples up the second auxiliary dial, so that its signal is sent in, and at the termination of the movement of the second auxiliary dial the main dial is coupled so that the signal is sent in by that, thereby allowing for sending in one, two or more auxiliary signals immediately preceding the main signal, so as to indicate what is wanted before the signal is sent in denoting the place to which the fire apparatus is to proceed.

In the aforesaid Letters Patent the dials themselves revolved and the electric circuit

was made and broken so as to indicate by successive taps denoting numbers the location of the fire.

We make use of a transmitter corresponding substantially with that in the aforesaid patent, but instead of revolving the dial we revolve an arm with a finger traveling over the edges of the dials and operating a circuit breaker so as to interrupt the electric pulsations sent out progressively on the respective fire alarm circuits.

In our present apparatus a circuit closing cylinder is made use of having projections that operate successively the circuit closing springs that lead to the respective fire circuits, and this cylinder revolves once for each number to be transmitted over the fire alarm circuits, and the interval between a set of taps indicating a certain number and the commencement of the taps to indicate the next number, is produced during the rotation of this circuit closing cylinder when the circuit is broken so that the current is cut off, this operation being substantially the same as in the aforesaid patent, and we arrange the circuits in such a manner that the movement of the arm and finger upon the periphery of the main dial or either of the auxiliary dials interrupts the circuit to produce the interval before mentioned when the signal is being given by either the main or either of the auxiliary dials.

In the drawings, Figure 1 is a partial diagrammatic elevation of the front of the machine. Fig. 2 is a section of the main dial and the parts acting therewith. Figs. 3, 4, 5, 6 and 7 are elevations of the respective dial plates. Fig. 8 is a plan view with the frame in section illustrative of the connections between one dial mechanism and the next, and Fig. 9 is a similar view of the main dial connections. Fig. 10 is a diagram of the circuit connections. Fig. 11 is a detached plan in larger size of the escapement for the hand lever. Fig. 12 is an elevation and Fig. 13 an edge view of the tumbler. Fig. 14 is a plan view of the coupling device. Fig. 15 is a partial elevation of the levers for one of the auxiliary dials as the parts are returning to their normal positions. Fig. 16 is an elevation of a modification of the lever devices used with

the main dial. Fig. 17 is a vertical section of the same. Fig. 18 is a sectional plan of part of the main dials, frame and connections, and Fig. 19 is a plan view at the upper ends of the devices shown in Fig. 16. Fig. 20 is a diagram of the circuit connections for the time stamp.

The frames A of the machine are to be of suitable size and shape, and the back and front frames are connected by the columns or pillars A', and the barrel B is provided with a ratchet wheel and a pawl upon the first gear wheel, and there is a cord a' to a weight a² by which the train of gearing is actuated, and in Fig. 1 we have represented by dotted lines the train of gearing by which the gear wheels C C' and C² are actuated, and adjacent to each wheel C C' C² is a crown ratchet wheel G, and the sliding coupling 3 is provided with pawls 4 that engage the crown ratchet wheel for connecting the motive power to the arm with the finger that travels around the dials for disconnecting such arm from the power to allow it to return to the normal position.

The coupling mechanism applied to each dial arm is the same and therefore it is only necessary to describe that mechanism with reference to one of the dials, and this coupling mechanism is represented most clearly in Figs. 2 and 14.

In the main signaling and in the auxiliary signaling devices there are dials, and usually it is only necessary to use five dials in each group. The dial K is stationary and it is received upon a hub 30 projecting from the bracket K', which bracket is permanently bolted to the face of the front frame, and the center of the hub 30 is axially in line with the shaft of the wheel C, and such hub 30 forms a bearing for one end of the shaft c, and the other end of the shaft c passes into a recess in the shaft of the gear wheel C, and to this shaft c the disk 2 is permanently fastened, through which the sliding coupling pawls 4 pass, and these pawls 4 are fastened at their back ends to the disk 3, and this disk 3 is permanently attached at one end of the sleeve H which can be slipped endwise upon the shaft c by the mechanism hereinafter described, so as to couple the pawls 4 with the crown wheel G or uncouple the same, and upon the outer end of the shaft c and adjacent to the back of the bracket K' the arm J is permanently fastened so as to revolve with such shaft c and with the coupling pawls, and there is a cord 8, preferably of wire, passing around the hub of the arm J and led off in any suitable direction to a weight 7 by which the arm J, the shaft c and the coupling pawls are returned to a normal position when the coupling pawls have been disconnected from the crown ratchet wheel by the end movement of the sleeve H. Upon the arm J is pivoted the circuit breaking lever I, and the insulated circuit springs 17 and 18 are also upon the arm J, and one end of the lever I acts against one of these springs

to separate the same from the other spring and break the circuit whenever the lever I is acted upon by one of the projections 12 upon the edge of either of the dials K or L.

It is now to be understood that upon the dials K and L are the projections 12 as in the aforesaid patent, and that when the arm J is coupled to the crown wheel G through the sleeve H and pawls 4, the rotation of the shaft c that carries the arm J causes the circuit breaking lever I and its lifter or finger 21 to traverse around a portion of the periphery of the dials, and whenever the lifter or finger 21 passes over one of the projections 12, the circuit between 17 and 18 is broken and the period during which the break occurs corresponds to one revolution of the circuit closing cylinder E upon which are rings and contact blocks e arranged to act in succession upon the circuit closing springs F F' to send out the signal upon the line, the same as in the aforesaid patent, thereby causing the pause between the taps given upon the signal bell or receiving instrument at the station and the next series of taps to indicate the numbers in succession, and these operations are the same whether the signals are sent out from the main dial No. 1, or whether preliminary signals are sent out by the auxiliary dial No. 2; and we have represented three sets of auxiliary dials so that three preliminary signals may be sent out, these auxiliary dials being designated No. 2, No. 3 and No. 4; and it is to be borne in mind that when only a single signal is to be sent out, the dials No. 1 alone are used; when one auxiliary signal is to be sent out the dials No. 2 are brought into action and they automatically set in action the signal from the main dial No. 1, and if two auxiliary signals are sent out the first one is sent from the dials No. 3, the second from the dials No. 2, and the main signal from the dial No. 1; and if three auxiliary signals are sent out, the first signal is sent from the dials No. 4, the second from the dials No. 3, the third from the dials No. 2, and the fourth from the main dial No. 1, the automatic mechanism hereinafter described being brought into action in the order stated for sending the respective signals.

The sets of dials for the main and the auxiliary signals are constructed somewhat differently from those in the aforesaid patent, and these dials are more clearly represented in Figs. 3, 4, 5, 6 and 7. The back dial K, Fig. 3, is permanently fastened upon the bracket K' and it has notches around a portion of its periphery, and the next dial L is adapted to be turned upon the hub 30 and it is provided with a sliding bolt or latch 10 adapted to engage one of the notches on the dial K, and in the dial L that is next to the dial K there is an opening, as represented in Fig. 4, so that by rotating the dial L the latch 10 of the dial which is next to the dial K, can be set in either of the notches of the dial K so as to uncover the desired number upon the surface of the dial K

composing the first number in the group of numbers to be sent out to form the signal. In the edge of the second dial L are notches, and upon the third dial is a latch 10 to engage either of the notches upon the periphery of the second dial when the proper figure on the first dial L is exposed through an opening in the third dial L, and so on, and in the outer dial L or cover plate there are openings through which the numbers upon the other dial may be seen, so that there being three dials L and the stationary dial K having numbers, allows any signal to be sent out representing any number up to nine thousand nine hundred and ninety-nine; and we remark that when all of the dials are turned back to a normal position, the projections 12 are all in line with each other and with the projection on the stationary dial K, and when the arm J is brought back to its normal position, the lifter 21 is over said projections 12 and the circuit is broken between the springs 17 and 18, and in the movement given to the arm J the circuit remains closed between the springs 17 and 18 except at the time that the lifter finger 21 is passing over the respective projections 12 upon the dials L, and the circuit closing cylinder E will make as many revolutions between one projection 12 and the next as may be indicated by the number on the dial behind the one having the projection that thereafter lifts the finger, and the revolution of the cylinder E when the circuit is broken by the lifter finger traveling over the projection 12, gives the interval between one set of taps and the next, the same as in the aforesaid patent.

It is to be understood that the gearing is properly proportioned for effecting the objects last mentioned, and we have represented two shafts D, each being adapted to receive a cylinder E and a set of circuit closing springs, so that the call may be sent out upon a large number of circuits to the respective fire alarm stations from the main or central station where the present apparatus is located.

Upon the back of the arm J of the main dial No. 1 is a tumbler R having a notch that engages the spring pawl or dog *r*, and upon this tumbler R is an incline 35 adapted to run under a stud 33 projecting from the back of the lever I so as to lift the lever and raise the finger 21 away from the dials, and upon the outer dial is a finger bar 14 against which the pawl or dog *r* comes into contact as the arm J reaches its farthest movement in giving the signals, and in so doing the tumbler R is unlatched from the pawl or dog *r*, and the spring of the tumbler throws the incline 35 under the stud upon the circuit breaking lever I and in so doing lifts the circuit breaking lever clear of the projections 12 and simultaneously breaks the circuit between the springs 17 and 18, and by this movement of the tumbler R the sleeve H is shifted longitudinally upon the shaft *c* to disconnect the

coupling pawls 4 from the crown ratchet wheel G and allow the arm J to be returned by the action of the weight 7; and to effect this object the lever U upon the back of the arm J is employed, one end of the lever U being adjacent to a collar 24 upon the sleeve H, and at the outer end of the lever U is a roller 25 adjacent to an incline 23 upon the tumbler R, and the parts are so positioned that when the pawl *r* is unlatched by the finger bar 14 and the tumbler is swung back, the lever U is actuated by the incline 23 to uncouple the shaft *c* from the crown wheel simultaneously with the lifting of the finger 21 and circuit breaking lever I, so that the parts are free to be revolved by the action of the weight 7 in restoring the parts to their normal position, and as the parts complete the backward movement, the end of the tumbler R comes in contact with the stud 22 on the frame of the machine, and the momentum is stopped and the arm J continues its movement until the pawl *r* engages the notch on the tumbler and the parts are restored to the position for use in the manner before stated, and in this movement the incline 23 passing away from the roller 25 on the upper end of the lever U allows the springs 5 to slide the sleeve H endwise and engage the pawls 4 with the crown ratchet wheel G unless the movement is arrested by a separate mechanism used in conjunction with the auxiliary dials, as hereinafter described; and we remark that if the main dial No. 1 alone is made use of, the return of the arm J to its normal position causes the engagement of the coupling pawls with the crown ratchet wheel, so that the parts are ready for a repetition of the movement, and when the movement of the main dial is finally stopped it is effected by a brake applied to the fly, as hereinafter described, and if one or more of the auxiliary dials is made use of, the act of setting such auxiliary dial for use and starting the same causes the uncoupling of the arm of the main dial, so that the same remains stationary until the auxiliary dial has performed its movement.

The fan or fly is represented at Q, and the same is driven by gear wheels substantially as in the aforesaid patent, but preferably such fan is on a vertical shaft and it is provided with a disk *l*, and there is a brake *p* in the form of a spring at the end of a bent lever *p'*, pivoted at 27, and one arm of this brake lever is adjacent to the shoulder or collar 28 upon the sleeve H. Hence when this sleeve H is drawn back to uncouple the pawls 4 from the crown ratchet wheel G at the main dial, the brake *p* engages the disk *l* and stops the fly and the train of gearing, and there is a lever *s* upon a small vertical shaft *s'*, and this lever *s* has a roller 29 adjacent to the shoulder 28 on the sleeve H and also a cam 26 adjacent to a stud 31 on the fan brake *p*, so that when this lever *s* is acted upon, the cam 26 acting against the stud 31 removes the brake to allow the fan to rotate, and the roller 29 adja-

cent to the shoulder 28 prevents the sleeve H sliding endwise and coupling the shaft and arm of the main dial with the clock movement until such times as the lever *s* and its shaft *s'* have been acted upon from the other dials, as hereinafter designated.

We provide an indicator S having upon it numbers to indicate the number of times that the arm of the main dial may be brought into action, and adjacent to this indicator is a hand lever T pivoted upon the frame and having an opening through which the figures upon the indicator can be observed, and upon the lever T an arm *t* extends out and is provided with escapement studs, and there is an escapement V pivoted upon a bracket extending out from the frame and having downwardly projecting studs that engage the studs upon the arm T, and there is a spring *p*⁵, see Fig. 1, to return the hand lever T to its normal position, and upon the escapement V is a stop finger *u* provided with a spring to hold it in its normal position, and there is a spring *u'* to act upon the escapement to retain the same in the position represented in Fig. 11, and there is a projection 41 at the upper end of the arm J which comes in contact with the stop finger *u* as the arm J returns to its normal position, and in so doing the escapement V is moved to allow one pin upon the arm *t* to pass by the escapement pins. Hence when the hand lever T is drawn back to the mark 1, 2, 3 or 4 upon the indicator S, the arm J will have as many movements as indicated by the numbers; that is to say, if the hand lever T is drawn back to 3 the escapement will be pulsated in so doing and it will hold the lever T against the action of its spring until the projection 41 on J acts against the finger *u* and moves the escapement, allowing one tooth to pass by and the lever T to come to the position 2, and in this movement the tumbler R as the lever J returns as aforesaid, acts upon the lever U and re-engages the coupling, so that the lever J is again swung and the circuit breaker carried partially around the dials and the tumbler is unlatched, the circuit breaker raised, and the lever J returned to its normal position, and in so doing the escapement is again acted upon, allowing the lever T to come to the position 1 and the coupling is again engaged and the lever J partially swung around the dials, the signal being again given, and as the lever J is returned to its normal position the escapement is acted upon and the lever T allowed to move from 1 to 0, and in so doing the lever U is acted upon to allow the pawls to engage the crown wheel, but the brake *p*⁴ on the lever T engages the disk *l* upon the fly shaft and stops the rotation of the train; and when the lever T is turned again by hand to 1 or a higher number upon the indicator S, the brake *p*⁴ of the fly is disengaged, allowing the parts to revolve as before described, but when an auxiliary dial is to give a signal before the main dial, that auxiliary dial is first to be set, and in so do-

ing the shaft *s'* and lever *s* are acted upon as hereinafter described, so as to draw back the sleeve H of the main dial and prevent its arm and circuit closer moving until after the signals have been given by the one or more auxiliary dials, and the termination of the signals by such auxiliary dials causes the lever *s* to move so as to free the sleeve H of the main dial and allow the springs to connect the pawls thereof with the crown wheel to start the movement of such sleeve and its arm J to give the signals from the main dial.

In consequence of the appliances at the auxiliary dials corresponding generally with those before described it is unnecessary to repeat the description of the parts employed at such auxiliary dials. The tumbler, however, that is provided with the auxiliary dials is preferably made in a slightly different manner, as indicated in Figs. 1 and 13, that is to say, the tumbler R' is longer and pivoted below the pivot of the lever U, and such tumbler R' has an elongated opening in it at the place where the pivot of the lever U is located, so that the tumbler R' is free to move upon its own pivot, and there is at the back of the arm J a stop dog *v* that is pivoted, and the upper end of the stop dog is adjacent to the upper end of the lever J, and the projection *v'* on the stop dog is opposite the stud *o* on the tumbler R', and when the tumbler R' is unlatched by the pawl *r* coming in contact with the stop bar 14, the spring of the tumbler R' causes the same to swing to the left, so that the stud *o* passes beyond the end *v'* of the stop dog, and the end *v'* holds the tumbler firmly so that it cannot swing back to be engaged by the pawl *r* until the upper end of the stop dog *v* comes in contact with the stud 16 upon the frame of the machine, and this unlatching of the stop dog from the tumbler R' is effected after the tumbler R' has struck with sufficient force against the rocker lever W to give the same the proper movement for the purposes hereinafter stated, and as the stop dog *v* comes against the stop 16 and the arm J is arrested by the same stop, the tumbler R' is no longer held by the stop dog but is in a position to be acted upon by the end 32 of the rocker lever W.

The rocker lever W is upon a pivot *f* upon the main frame, and its lower end is made as a double incline against which a roller upon a spring *g* acts to hold such rocker lever W in either one direction or the other, and there is a thumb-piece *i* upon the upper end of the rocker lever W and a similar thumb-piece *i'* upon the upper end of the arm J, and when the auxiliary dial No. 2 is to be started, these thumb pieces *i* *i'* are grasped between the thumb and finger and pressure applied to cause the end 32 of the rocker lever W to act against the tumbler R' and swing it on its pivot until such tumbler is caught by the dog *r*, and in so doing the incline on the back of the tumbler R' is moved away from the lever U, so that the springs act upon the

sleeve H and slip the same endwise upon the shaft *c* to engage the coupling and cause the shaft *c*, sleeve H and arm I to partially revolve to give the signal by the first auxiliary dial No. 2, the same as before described in connection with the main dial, but as before mentioned, in the position that the main dial was left at the end of its previous signal on a former occasion, the brake *p* arrested the movement of the fly. We therefore make use of the arm *m* upon the lower end of the shaft *s'*, and the link *n* extending from said arm *m* is united to the rocker lever W either directly at the back of such lever or to an arm extending up from the hub of the lever that surrounds its pivot, so that when the rocker lever W is moved by grasping the same with the fingers as before mentioned, the arm J remains against the stud 16 while the movement before mentioned is given to the tumbler R', and the motion of the rocker lever W acts through the link *n* and arm *m* to partially turn the shaft *s'* sufficiently to cause the cam 26 to press the stud 31 and the brake *p* sufficiently away from the disk of the fly to allow the fly to rotate, and in giving the movement aforesaid to the rocker lever W the inclined end passes to the other side of the roller upon the spring *g*, so that such roller and spring hold the rocker lever W with a sufficient force to prevent the said lever W falling back into the position shown in Fig. 1 when liberated from the grasp of the fingers.

In the movements before mentioned as given to the shaft *s'*, the roller 29 has acted upon the shoulder 28 and slipped the sleeve H endwise so as to uncouple the pawls 4 from the crown wheel G of the main dial, so that the arm J of the main dial remains stationary, but as the arm J of the first auxiliary dial No. 2 returns to its normal position and the tumbler R' is held by the stop dog *v*, the end of the tumbler R' comes forcibly against the end 32 of the rocker lever W, throwing the same back into the position indicated in Fig. 1, with the roller of the spring *g* at the other side of the inclined end, and in this return movement of the rocker lever W to its normal position, the link *n* and arm *m* are acted upon and the shaft *s'* turned sufficiently to allow the roller 29 to move away from the shoulder 28 to allow the springs of the sleeve H to move the same endwise and engage the coupling pawls 4 with the crown ratchet wheel in order that the rotation of the wheels may give motion to the arm J of the main dial, and in this movement the shoulder 28 acting against the bent lever arm of the brake *p*, holds the brake out of the way so that the fan is not stopped until upon the return movement the lever U upon the arm J of the main dial draws back the sleeve H and uncouples the connection to the crown ratchet wheel by acting against the collar 24 upon said sleeve H, as before described.

Substantially the same devices that have

been described as applied at the auxiliary dial No. 2 are provided at the auxiliary dial No. 3 where such dial is made use of, and at an auxiliary dial No. 4, if the same is provided, and these act in succession substantially as before described; that is to say, the rocker lever W' at the auxiliary dial No. 3 is connected by a link *n'* to a bent lever *s'* with a roller at its end acting against the shoulder 28 on the sleeve H of the auxiliary dial No. 2, and where there is a third auxiliary dial No. 4, the link *n''* extends from the rocker lever W² to a bent lever *s''*, the roller at the end of which is adjacent to the shoulder 28 upon the sleeve H of the second auxiliary dial No. 3, so that the operation of the machine as a whole when all the dials are employed is as follows:

The dials L of the main dial No. 1 are set to indicate the number of the alarm box adjacent to the fire; the lever T is moved by hand upon the indicator S according to the number of times this number is to be repeated; the dials of the first auxiliary dial No. 2 are set to give a third signal before the signal is given by the main dial No. 1; the dials of the third auxiliary dial are set to give the previous signal, and the dials of the fourth auxiliary dial are set to give the first signal; then the lever W² is acted upon by the thumb and finger to latch the tumbler R' of that dial by its dog *r*; then the lever W' is moved by the thumb and finger to perform the same duty for the auxiliary dial No. 3, and then the lever W is moved by the thumb and finger to perform the same duty for the auxiliary dial No. 2, and in so doing the fly of the movement is liberated from the brake and the gearing starts to revolve. The arm J of the main dial cannot move, because its sleeve is not coupled as aforesaid. Neither can the arm of the auxiliary dial No. 2 move, because the lever *s'* holds the sleeve H of the auxiliary dial No. 2, so that it is uncoupled, and the lever *s''* holds the sleeve H of the auxiliary dial No. 3, so that it is uncoupled, but in the act of moving the lever W² the lever U of the dial No. 4 has been released by the incline on its tumbler R' moving away from the upper end of the lever U, so that the sleeve H of the auxiliary dial No. 4 has been moved endwise by its spring, and the pawls are coupled with the crown wheel in the gearing and the arm of the dial No. 4 and the circuit closer carried thereby are moved partially around the dial and the signal sent as before described. The dog *r* is unlatched at the end of this movement, the tumbler R' is thrown back by its spring, and the lifter 21 raised, the incline on the tumbler acts upon the lever U of the dial No. 4, and the tumbler R' is moved forcibly against the rocker lever W², and in so doing returns the same to the normal position represented in Fig. 1, and moves the bent lever *s''* away from the shoulder 28 of the sleeve H of the auxiliary dial No. 3, allowing such sleeve to be moved endwise by its spring to

connect the coupling, so that the sleeve, its shaft and its arm J are rotated, carrying the circuit breaker partially around the dial and giving the signals from the auxiliary dial No. 3; its dog is liberated from the tumbler R', this is thrown back by its spring, the lever U is acted upon, the sleeve H drawn back to uncouple the same from the gearing, the arm J and parts connected with it are returned back by the action of the weight and cord as aforesaid, and its tumbler R' strikes forcibly against the rocker lever W' and moves the same back into the position shown in Fig. 1, and in so doing the lever s^2 is moved away from the shoulder 28 on the sleeve H of the auxiliary dial No. 2, and such sleeve is carried by its springs to engage the crown lever, and the movements before described are given to the arm J of the auxiliary dial No. 2 to send a signal from the same, its dog r is unlatched, the tumbler R' is thrown back by its spring, the lever U is acted upon by the incline of the tumbler, the sleeve H is drawn back and uncoupled, the circuit closer is lifted, and the arm and sleeve are returned to their normal position by the weight and cord as aforesaid, and in so doing the rocker W is acted upon and through the link n , arm m and shaft s' the sleeve of the main dial is allowed to slide by the action of the spring, and the parts of the main dial are brought into action, the signal sent and either repeated or not according to the position in which the hand lever T may have been placed in preparing the instrument for the sending of the signals and as before described with reference to the movements of the parts of the main dial.

The advantages of this instrument will be apparent because where only the main signal has to be sent, the same can be operated in a manner generally corresponding to that in the aforesaid patent, the details of the mechanism however varying as before described, but where a preliminary signal or two or more preliminary signals are to be sent, it is only necessary to bring into action one or more of the auxiliary dials and the preliminary signal sent indicates what is wanted, such for instance as a hook and ladder, an engine, a water tower or anything else that may be indicated by the code is first denoted and then the place to which the desired articles are to proceed is indicated by the last number that is sent by the main dial, and the signal sent by the main dial is frequently repeated two or three times according to a prearranged code, and this repetition of the signal is sometimes used as a call to indicate that all the engines or the apparatus within a certain district are required in consequence of the emergency of the situation.

In most fire alarm systems a time stamp is made use of in connection with the incoming signal from the local alarm boxes, as it is important to ascertain whether or not the sig-

nal has been sent out from the main station to the respective engine-houses with the proper promptness. We therefore arrange, in connection with the present apparatus, a local time circuit and time stamp, there being upon one of the shafts D a projection d adjacent to circuit closing springs d' , so that when the shaft D commences to rotate, the projection d closes the circuit through the spring d' in the local circuit represented in Fig. 20, and there is another projection 6 which comes into contact with a snap switch 9, which snap switch being acted upon by the projection 6, breaks the circuit, but this does not occur until after a time stamp M in the local circuit has been impressed by the electro-magnet in that circuit to mark as usual by such time stamp devices the time at which the train of gearing is started, and this snap switch remains broken by the action of its spring until the arm 11 upon the hand lever T acts against the snap switch to restore the same to its normal position, and this occurs as the hand lever T is returned to its normal position and the fly stopped. Hence there is but one impression made by the time stamp, because the circuit is only closed when the signaling apparatus before described is started. There are two springs d' , as illustrated in Fig. 20, so that the circuit is closed by the contact with them of the projection d .

The circuit connections for the electric current may be made in any suitable manner without changing the mechanism or the mode of operation heretofore described. We however find that it is convenient to place upon each of the sleeves H insulated metallic rings y with adjacent stationary contact springs z , and to connect from the respective rings y insulated wires running in grooves or otherwise within the sleeves H to the respective circuit closing springs 17 and 18, and these circuit connections being made in multiple arc, as illustrated in Fig. 10, no current can pass upon the line when the instrument is at rest, because the lifters 21 being elevated on the projections 12, the springs 17 and 18 are all separated, but when either of the dials is brought into action the circuit is closed through the rings y and contact springs of the particular dial by the lifter 21 clearing the projection 12 and allowing the spring 17 to close contact with the spring 18, and then the pulsations will be sent from the battery out onto the circuits to the engine-houses in succession by the rotation of the shaft D by which the successive contact blocks e close the circuits through the springs F, the springs F' being constantly in contact with the rings 19 and 20 of the cylinder E, as in the aforesaid patent, and consequently the circuit is broken from the battery whenever a projection 12 lifts the finger 21 and by the lever I breaks the circuit between 17 and 18 during one rotation of the cylinder E, so as to produce the pause between the taps that denote

one number and the taps that denote another number.

By reference to the diagram, Fig. 10, it will be seen that the circuits are closed and broken by whichever of the main or auxiliary dials may be in operation.

In the modifications represented in Figs. 16, 17, 18 and 19, the dials and the coupling devices remain unchanged, but the mechanism for actuating the coupling sleeve H and for actuating the lifter finger 21 is modified. The lifter finger 21 is upon the lever N, the axis 40 of which passes through the arm J', and it is provided with a crank arm 41 behind the arm J', and the pin 42 projects from the crank arm through a mortise in the arm J' to act upon the circuit breaking spring 17 to make and break the circuit as the arm J' is partially rotated in the manner before described, and there is a fixed tubular crank pin 43 upon the arm J' and through which the axis 40 passes, and around this tubular crank pin 43 is a sleeve 44 with a projecting latch 45 and an arm with a stud 46. The shaft O occupies nearly a radial position to the shaft c and it is supported at the inner end by a bearing 47 and at the outer end by a bearing 48 extending from the arm J', and near the lower end of the shaft O is a crank arm 49 to a link 50 that connects with the sliding sleeve H, so that when this shaft O is partially rotated in one direction the coupling pawls 4 engage the crown wheel G, and when it is moved in the other direction these parts are disconnected, and near the upper end of the shaft O an arm 51 extends outwardly, and there is a stop finger 52 fastened upon the frame of the machine, so that when the arm J' is brought back to a nearly vertical position the arm 51 striking the stop finger 52 turns the shaft O to cause the pawls to engage the crown wheel G, and when the arm J' is being rotated by the action of the clock mechanism to give the signals, the arm 51 comes in contact with the stop 14 on the dial L, and the shaft O is turned in the opposite direction to disconnect the pawls 4 from the crown wheel G and allow the shaft c and parts connected therewith to be brought back by the action of the weight and cord 8. There is a stud 53 standing upwardly from the arm 51, and its upper end engages the latch 45, and there is a spring 54 that tends to turn the sleeve 44 and engage the latch 45 with the stud 53; and it will be observed that this latch 45 engaging the stud 53 holds the shaft O from turning during the swinging movement of the arm J' in giving the signals, and the stud 46 first engages the finger bar 14 and disconnects the latch 45 from the stud 53 and then the arm 51 can turn the shaft O by such arm 51 coming into contact with the finger bar 14 on the dial to disconnect the rotating mechanism as aforesaid, and while the arm J' is being swung back by the action of the cord 8 to its normal position, the flat under portion of the latch 45 is resting upon the top of the stud 53,

and hence as soon as the arm 51 engages the stop finger 52, and the shaft O has been turned to connect the coupling, as aforesaid, the latch 45 engages the stud 53 to hold the parts in position as before mentioned. Behind and in line with the stud 46 is a pin 55 which is adjacent to the crank arm 41, and hence when the stud 46 has been acted upon and the latch 45 lifted and held up by resting upon the upper end of the stud 53, the pin 55 has acted upon the crank arm 41 and by the pin 42 has separated the spring 17 from the spring 18 and thereby broken the electric circuit, so that no signal is given by the return movement as the arm J' is swung back to its normal position, and during this time the lifter finger 21 has also been held up in an elevated position and out of action by the connection from the crank arm 41, axis 40 and lever N carrying said lifter finger 21, so that by this movement the circuit connections as well as the coupling devices are reliably actuated.

We find it advantageous to prevent the arm J' being swung back too rapidly, and with this object in view we provide a separate pulley 56 for the cord 8 which leads to the return weight or spring, and this pulley 56 is fastened upon the shaft c, as seen in Fig. 17, and through a mortise in this pulley 56 the link 50 passes, and the hub of this pulley 56 is sufficiently large for receiving around it a loose gear wheel 57 which engages a pinion 58 of the fly 59, and there is a pawl 60 upon the loose gear 57 engaging a ratchet wheel around the pulley 56, so that when the shaft c is being turned by the gearing and the signal given, the ratchet wheel and pulley rotate without turning the loose gear 57, but as soon as the arm J' commences the return movement by the action of the cord 8 after the coupling has been disconnected, the pawl 60 engages the ratchet wheel and turns the gear and fly so that the movement of the parts can be more or less rapid according to the size of the fly.

We claim as our invention—

1. A stationary dial, two or more movable dials adapted to being set to denote numbers and provided with projections, in combination with an arm, a shaft and mechanism for partially rotating the shaft and arm, a circuit closer carried by the arm and acted upon by the projections of the dials to break the circuit, circuit closing springs and a revolving cylinder acting with the springs to send the electric pulsations upon the respective circuits, and mechanism for returning the arm to its normal position, substantially as set forth.

2. A stationary dial and one or more moving dials having projections and means for locking the dials in their relative positions, in combination with a shaft, gearing and mechanism for driving the gearing, a sleeve upon the shaft and coupling mechanism, an arm carried by the shaft, circuit closing and breaking mechanism upon the arm and acted upon by the projections of the dial, and mechanism for moving the sleeve to couple and uncouple

the same from the gearing, substantially as set forth.

3. The combination with a stationary dial and one or more moving dials and mechanism
5 for holding the dials in the positions to which they may be moved, a shaft and arm carried by the shaft, coupling mechanism and gearing with which the shaft and arm are coupled
10 and uncoupled, circuit closing mechanism carried by the arm and actuated by the dials for sending pulsations into the electric circuit corresponding with the indentations of the dials, substantially as set forth.

4. A set of dials and a support for the same
15 and means for holding the dials in their proper relative positions after they have been adjusted for sending a signal, in combination with a shaft and arm, mechanism for partially rotating the shaft and the arm, circuit
20 closing mechanism carried by the arm and acted upon by the dial, a sleeve upon the shaft, gearing for driving the same and coupling mechanism acted upon by the sleeve, means for moving the sleeve to couple the
25 same to the gearing, automatic mechanism brought into action at the end of the movement of the arm for uncoupling the sleeve, and means for returning the arm, sleeve and shaft to their normal position, substantially
30 as set forth.

5. A series of dials and means for holding the same in their proper relative positions after they have been adjusted, there being
35 projections on the dial, in combination with a shaft, an arm connected with the shaft and circuit breaking mechanism carried by the arm and acted upon by the projections of the dials, a sleeve upon the shaft, and coupling
40 mechanism for engaging the gearing, a tumbler and dog for holding the tumbler and carried by the arm, a finger supported by the dial and acting to unlatch the dog, a lever acted upon by the tumbler and giving end motion to the sleeve, and means for returning
45 the arm to its normal position after the sleeve has been uncoupled, substantially as set forth.

6. The stationary and movable dials having
50 projections and means for holding the dials in the position to which they may be adjusted, in combination with a shaft and arm carried by the shaft, a circuit breaking lever having a finger projecting over the periphery of the dials, circuit springs acted upon by the said lever, a tumbler and dog carried by the arm,
55 means for unlatching the dog, a spring for acting upon the tumbler, said tumbler having an incline that raises the circuit closing lever and breaks the circuit, and a weight and cord for returning the arm to its normal position,
60 substantially as set forth.

7. The stationary and movable dials having
65 projections and means for holding the dials in the position to which they may be adjusted, in combination with a shaft and arm carried by the shaft, a circuit breaking lever having a finger projecting over the periphery of the dials, circuit springs acted upon by the said

lever, a tumbler and dog carried by the arm, means for unlatching the dog, a spring for acting upon the tumbler, said tumbler having
70 an incline that raises the circuit closing lever and breaks the circuit, a weight and cord for returning the arm to its normal position, and a stop with which the tumbler comes into
75 contact at the end of the return movement for automatically setting the said tumbler, substantially as set forth.

8. The stationary and movable dials having
80 projections and means for holding the dials in the position to which they may be adjusted, in combination with a shaft and arm carried by the shaft, a circuit breaking lever having a finger projecting over the periphery of the dials, circuit springs acted upon by the said lever, a tumbler and dog carried by
85 the arm, means for unlatching the dog, a spring for acting upon the tumbler, said tumbler having an incline that raises the circuit closing lever and breaks the circuit, a weight and cord for returning the arm to its normal
90 position, a stop with which the tumbler comes into contact at the end of the return movement for automatically setting the said tumbler, gearing and a coupling mechanism, a lever carried by the arm and acted upon by an
95 incline on the tumbler for connecting and disconnecting the coupling mechanism, substantially as set forth.

9. The stationary and movable dials having
100 projections and means for holding the dials in the position to which they may be adjusted, in combination with a shaft and arm carried by the shaft, a circuit breaking lever having a finger projecting over the periphery of the dials, circuit springs acted upon by the said
105 lever, a tumbler and dog carried by the arm, means for unlatching the dog, a spring for acting upon the tumbler, said tumbler having an incline that raises the circuit closing lever and breaks the circuit, a weight and cord
110 for returning the arm to its normal position, a stop with which the tumbler comes into contact at the end of the return movement for automatically setting the said tumbler, gearing and a coupling mechanism, a lever
115 carried by the arm and acted upon by an incline on the tumbler for connecting and disconnecting the coupling mechanism, a hand lever and indicator, and an escapement for holding the hand lever and which escape-
120 ment is acted upon by the arm upon its return movement for repeating the signal two or more times, substantially as set forth.

10. The combination in an electric signaling mechanism, of a rotary circuit closer and
125 numerous circuits into which the circuit closer directs the currents in succession, two or more dials and their rotating and circuit closing devices and automatic mechanism substantially as specified for bringing the
130 second dial mechanism into action after the first dial has completed its movement, substantially as specified.

11. The combination in an electric signal-

ing mechanism, of a cylinder and circuit closing springs, means for revolving the cylinder and sending out pulsations upon the respective circuits, a battery and two or more circuit closing springs, two or more dials and mechanism for actuating the circuit closing springs to break the electric circuit to the cylinder and produce the interval between one set of pulsations and the next, and mechanism brought into action by the first dial for giving motion to the second dial, substantially as set forth.

12. The combination in an electric signaling apparatus, of a main dial and two or more auxiliary dials, an arm to each dial, a shaft carrying the same, coupling mechanism and gearing with which the coupling mechanism engages, mechanism for holding the coupling devices out of engagement, and rocker levers acted upon in succession by the dial mechanism to permit the coupling mechanism to engage the gearing of the second dial after the signal has been given by the first dial and to engage the mechanism of the main dial after the movement of the mechanism of the second or auxiliary dial, substantially as set forth.

13. The combination with the main and auxiliary dials and the mechanism therewith connected for sending the respective signals, of the actuating mechanism, the sliding

sleeves and coupling mechanism, the rocker levers, the links and levers therewith connected for holding the sleeves and coupling mechanism out of engagement, a fly for regulating the movement of the gearing, a brake for stopping the fly, and a lever arm for removing the brake to allow the rotation of the parts, the rocker levers being acted upon in succession by the signaling mechanism of the respective dials to automatically bring into action the mechanism of the dials in succession, substantially as set forth.

14. The combination with the dials having projections, of an arm, a shaft for carrying the arm, a sleeve sliding upon the shaft and coupling mechanism actuated thereby, a lever on the arm for drawing back the sleeve, a tumbler carried by the arm, and a dog for holding the same, a rocker lever and its spring against which the tumbler strikes upon the return movement of the arm to actuate the rocker lever, and a stop dog for holding the tumbler in giving its motion to the rocker lever, substantially as set forth.

Signed by us this 2d day of June, 1894.

FREDERICK PEARCE.
JOS. BROICH.

Witnesses:

GEO. T. PINCKNEY,
A. M. OLIVER.