

G. R. Duval.

Gang Plow.

N^o 100,383.

Patented Mar. 1, 1870.

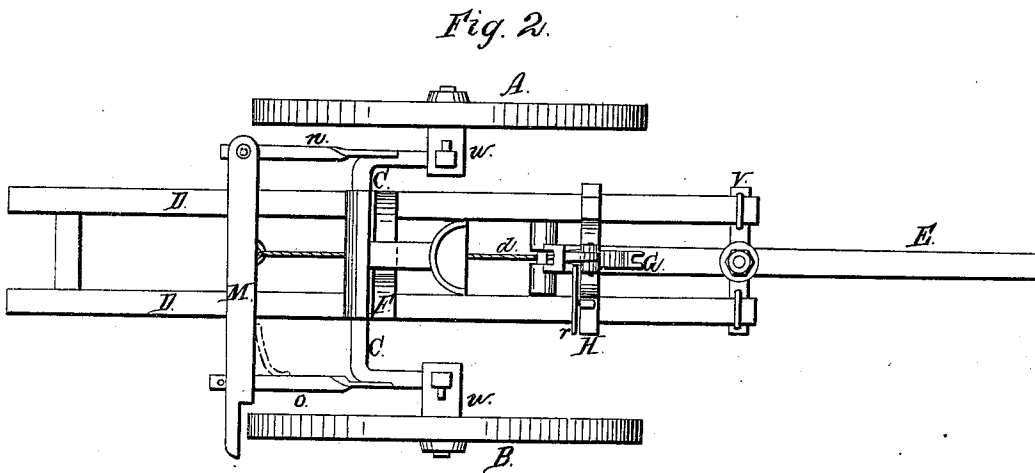
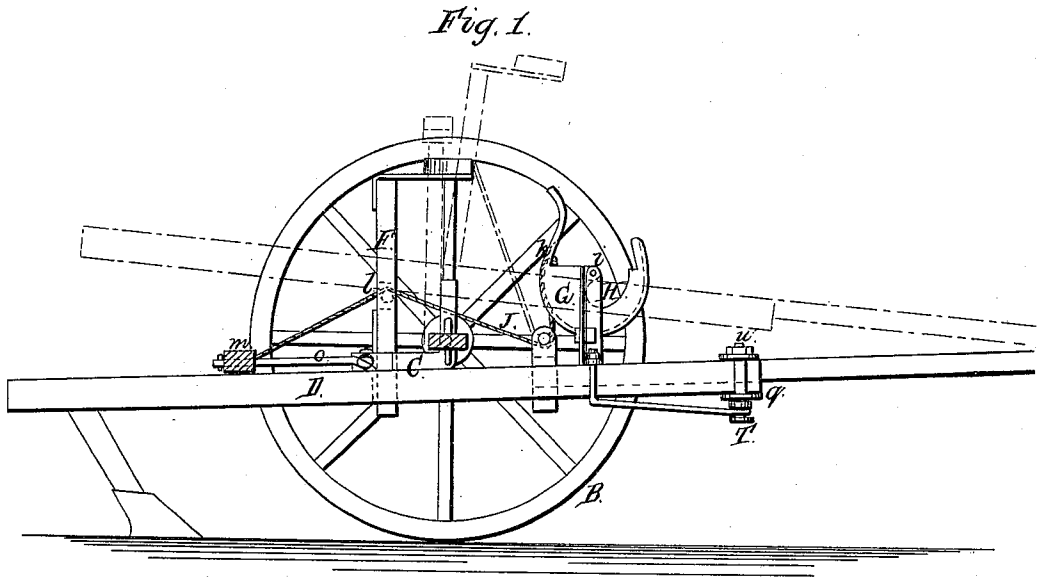

Witnesses.

A. Bennekensoff

Jno. T. Brooks

Inventor.

G. R. Duval

PER

Wm. S. Co.
Attorneys

United States Patent Office.

GEORGE R. DUVAL, OF SALEM, OREGON.

Letters Patent No. 100,383, dated March 1, 1870.

IMPROVEMENT IN GANG-PLOWS.

The Schedule referred to in these Letters Patent and making part of the same

To all whom it may concern :

Be it known that I, GEORGE R. DUVAL, of Salem, in the county of Marion, and State of Oregon, have invented a new and useful Improvement in Gang-Plows; and I do hereby declare that the following is a full, clear, and exact description thereof, which will enable others skilled in the art to make and use the same, reference being had to the accompanying drawings forming part of this specification.

This invention relates to new and useful improvements in gang-plows, and consists in the method of raising and lowering the plow from the ground, and in the construction and arrangement of parts as herein-after more fully described.

In the accompanying plate of drawings—

Figure 1 represents a side elevation of the machine. Figure 2 is a top view.

Similar letters of reference indicate corresponding parts.

This machine rests on two wheels, A B, connected together by the crooked and sectional axle C.

D represents the beams.

E is the tongue.

F is an upright, fastened to the beams.

The axle is fastened in the angle formed by the upright and the beams, in such a manner that it turns as on a journal.

When in an upright position, the piece F is on a line with the arms of the axle, and the plows, which are attached to the back part of the beams, are raised from the ground.

When it is placed in the position seen in the drawing, the plows are in the ground.

To thus raise and lower the plows, there is a circular foot-lever, G, confined in a stand, H, on the beams, which turns on the pivot i.

J represents a chain, which is attached to the lever at the point k, from whence it passes down in a groove in the lever, and under a pulley, which is supported by a stand on the back end of the tongue.

From this pulley the chain passes under another pulley in the upright F, as seen at l, and is attached to a cross-piece or brake m.

This brake m is pivoted at one end to a bar, n, which is fastened to the axle.

At the other end it is confined by another bar, o, which is also fastened to the axle.

P is the driver's seat.

Now, by bearing on the lever G with the foot, the driver can readily raise the angular portion of the axle to an upright position. This throws up the back end of the beams, and raises the plows from the ground. When thus raised, the lever G is held in position by means of a dog, r, which drops into a notch in the lever.

When in the field and ready for operation, the dog is detached from the lever by a slight pressure of the foot, when the back end of the tongue drops, partially revolving the lever G, which loosens the chain. The chain being loosened, the axle turns on its journal, the angular portions S S drop down to a horizontal position, as seen in the drawing, and the plows take the ground.

The brake m is drawn down on to the wheel by the cord, when the pulley, under which it passes, is properly placed in the upright.

A spring may be used in combination with the brake, if desired, for assisting in the operation of braking.

The draught of the machine is at the point T, beneath the tongue from the bolt u, which is adjustable laterally (with the tongue) by means of the slotted plate v, by which the front ends of the beams are connected together.

The axle C is adjustable in the arms of the wheels w, and is fastened in the arms by keys, or in any suitable manner.

Having thus described my invention,

I claim as new and desire to secure by Letters Patent—

The hinged and adjustable axle C and the lever G, with the parts connected therewith, that is to say, the chain J, bars n and o, tongue E, and brake m, in combination with a gang-plow, arranged and operating substantially as described.

GEORGE R. DUVAL.

Witnesses:

H. CARPENTER,
R. C. GEER.