



US 20140090326A1

(19) **United States**

(12) **Patent Application Publication**  
**Jedia**

(10) **Pub. No.: US 2014/0090326 A1**

(43) **Pub. Date: Apr. 3, 2014**

(54) **AESTHETIC WALL FACADE SYSTEMS, DEVICES, AND METHODS**

(52) **U.S. Cl.**  
CPC ..... *E04F 13/08* (2013.01)  
USPC ..... *52/506.05; 52/745.09*

(71) Applicant: **Hunter Douglas Chile S.A.**

(57) **ABSTRACT**

(72) Inventor: **Carlos Bernardo Gonzalez Jedia, Nunoa (CL)**

A cladding for facades or walls which is made up of a plurality of panels, where adjacent panels have different curvatures, in which said cladding (1) is comprised of a plurality of convex panels (2) and a plurality of concave panels (3), which are alternately installed in a contiguous manner; in which each of the panels (2, 3) which form the plurality of convex panels (2) and concave panels (3) is installed on a first profile (4) and a second profile (5); said profiles (4, 5) are formed by a first portion (6) in a "C" shape and a second portion (7) in an inverted "C" shape, in which the first portion (6) in a "C" shape has in the outer part of its wings a first plurality of serrated teeth (8) and the second portion (7) in an inverted "C" shape has on the inside of its wings a second plurality of serrated teeth (9), which, once pushed against one another, are joined by the tongue and groove connection generated by the serrated teeth (8, 9); where the first portion (6) in a "C" shape is fastened to the wall (12) with screws and the second portion (7) is then wedged in the first portion (6) through said serrated teeth.

(73) Assignee: **Hunter Douglas Chile S.A.**

(21) Appl. No.: **13/958,551**

(22) Filed: **Aug. 3, 2013**

(30) **Foreign Application Priority Data**

Aug. 3, 2012 (CL) ..... 2170-2012

**Publication Classification**

(51) **Int. Cl.**  
*E04F 13/08* (2006.01)

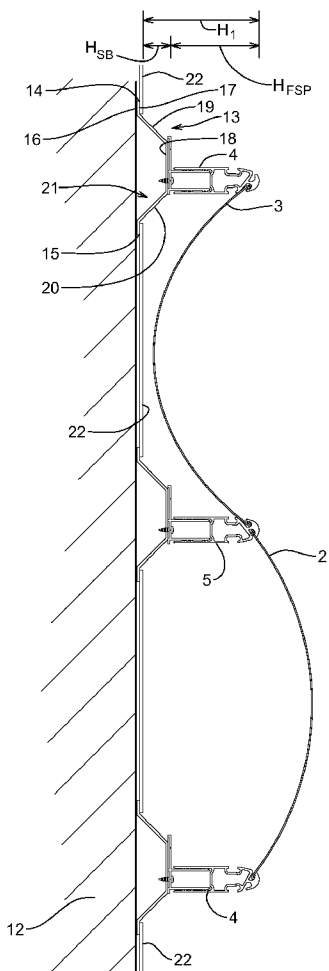

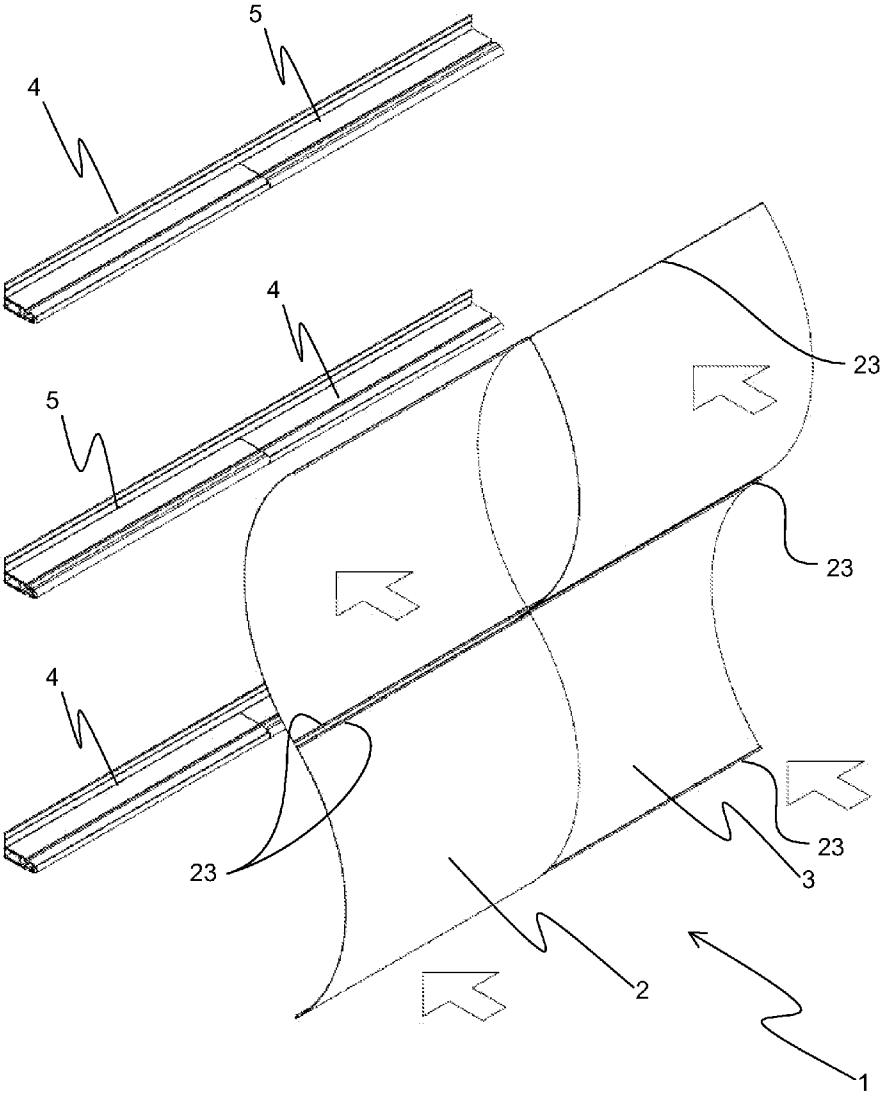

FIG. 1

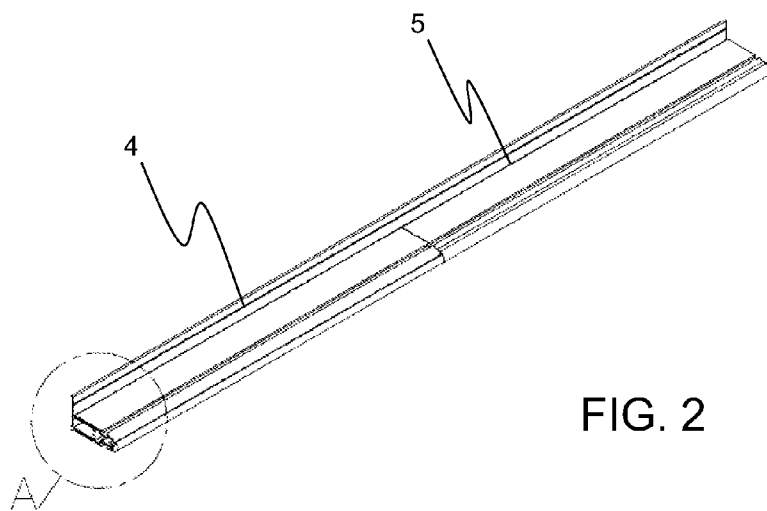

FIG. 2

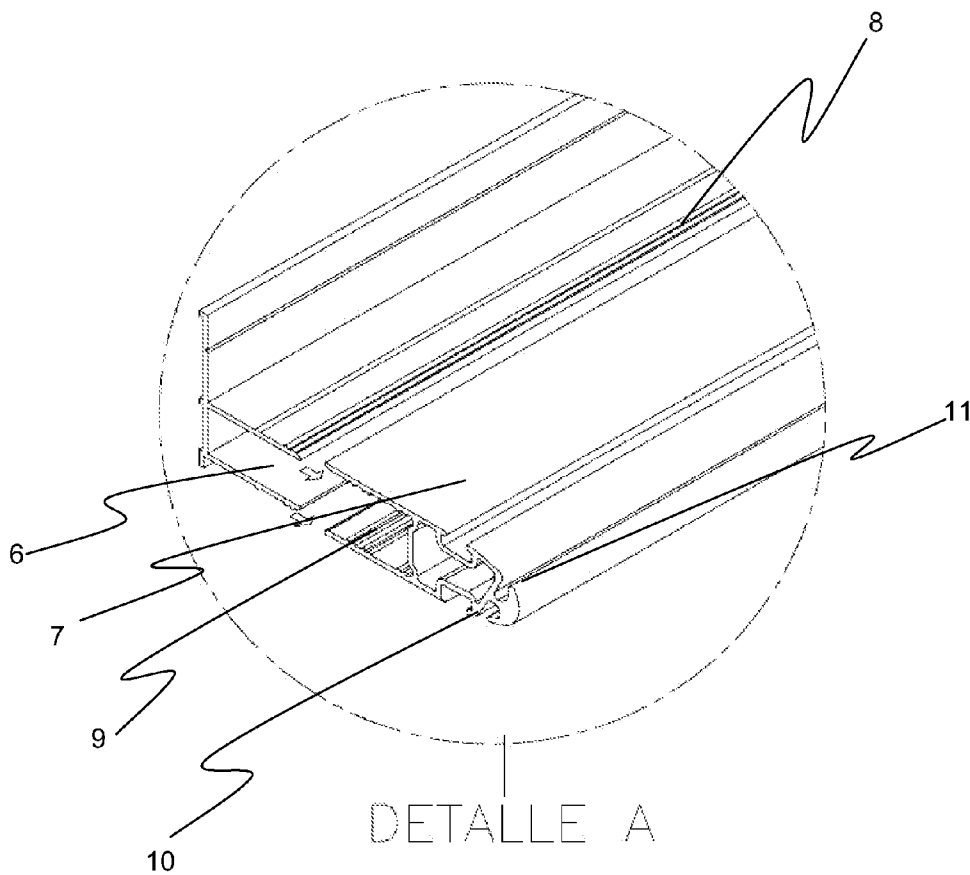

FIG. 3

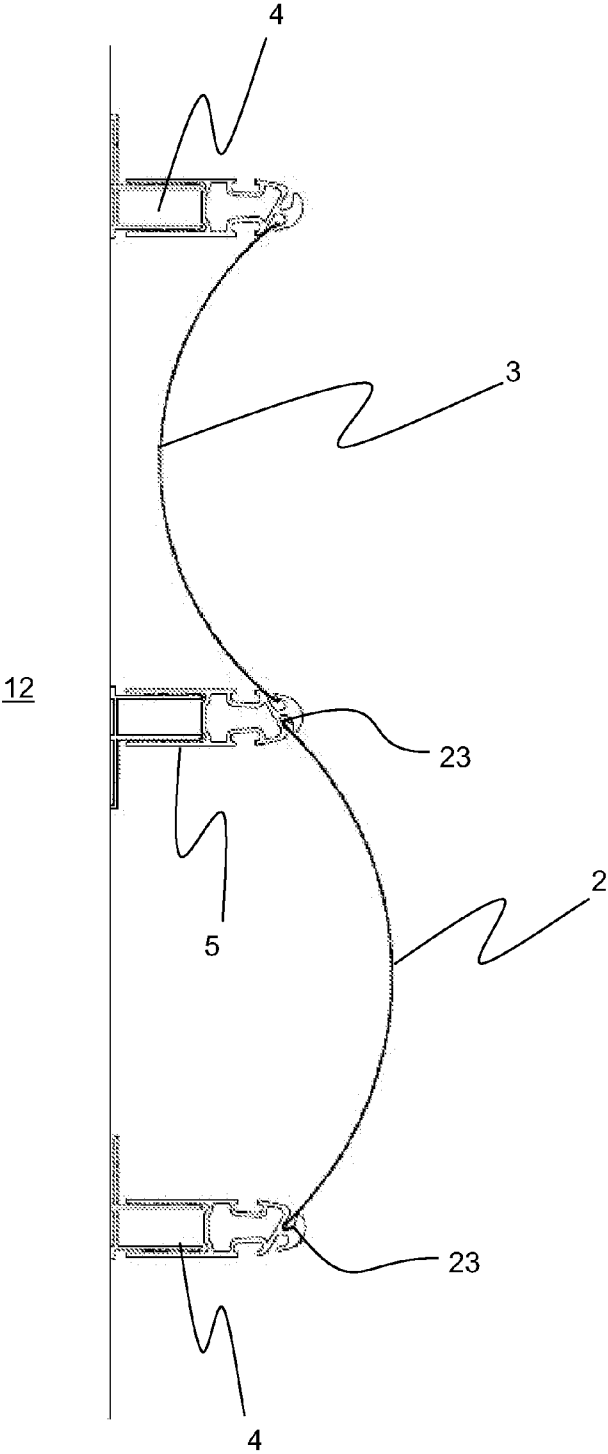

FIG. 4

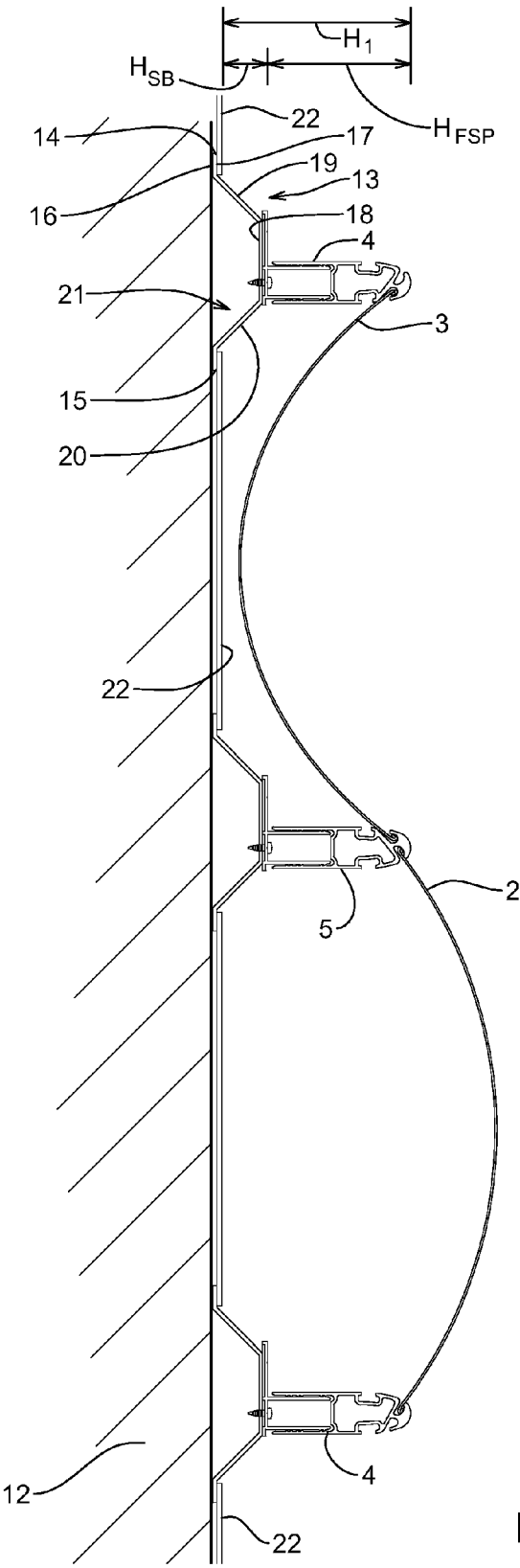

FIG. 5

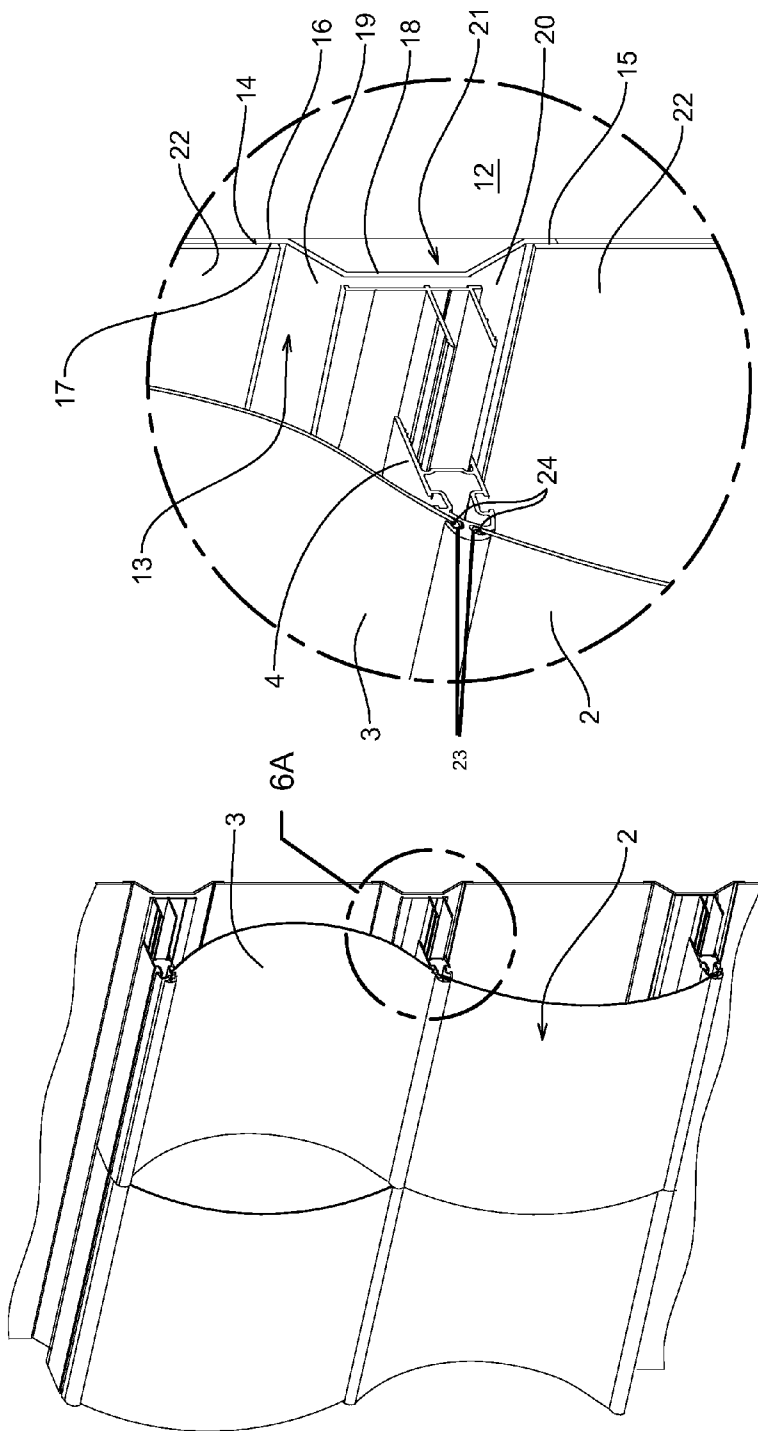

FIG. 6A

FIG. 6

**AESTHETIC WALL FACADE SYSTEMS,  
DEVICES, AND METHODS**

**CROSS-REFERENCE TO RELATED  
APPLICATIONS**

**[0001]** This application claims priority to and the benefit of Chilean utility model application number 2170-2012, filed Aug. 3, 2012, the entire content of which is incorporated herein by reference.

**BACKGROUND OF THE INVENTION**

**[0002]** 1. Technical Field of the Invention

**[0003]** The present utility model relates to a cladding system for facades or walls which is composed of a plurality of panels, where adjacent panels have different curvatures, a first concave curvature and a second convex curvature.

**[0004]** 2. Background of the Invention

**[0005]** There are currently several types of metallic claddings for facades that act as wall coatings, but usually they are difficult to install, so a solution that is simple and minimizes installation time is being sought out.

**[0006]** Several cladding systems can be found in the state of the art, such as, for example, ones in document WO 2007/051541 which relates to a facade cladding of buildings using juxtaposed metal cladding panels. The system comprises rails fastened to the façade and thin metal cladding panels juxtaposed and placed in parallel to the facade, each panel being equipped, on its side facing the façade, with fastening elements attached to said panel by means that do not go through it, said fastening elements being designed so as to cooperate with said rails, this cooperation defining for each panel a single attachment point without any degree of freedom; sliding attachment points that allow the degree of freedom needed for the free thermal expansion of the panel.

**[0007]** Document EP 1233118 (Giesenkamper et al.) describes a facade cladding system which is detachably fixed to an infrastructure fastened to a wall of a building and which comprises cladding panels configured rectangularly with parallel longitudinal sides and transverse sides, as well as front faces arranged at a distance from the building wall, having angled longitudinal and transverse sides starting from the front faces towards the building wall, wherein the cladding panels are supported by rectangular bottom panels fastened to the infrastructure, and the longitudinal sides of the cladding panels being hooked next to the longitudinal sides of the bottom panels, on the longitudinal sides of the bottom panels.

**[0008]** Document FR 2563262 discloses an assembly for the cladding of the facades of a building. This cladding comprises a set consisting of rectangular metal panels which have longitudinal folds at the ends to enable their fastening onto a structure of uprights that are firmly fixed on the outer face of the building, in such a way that when the panels are placed horizontally, they give the building an ornamental look. These cladding systems are used on the facades of buildings in order to waterproof these facades.

**[0009]** Document ES 1063739 discloses a perforated or stretched metal tray for facades that is ventilated, made of metal, built in punched plates, pressed, stretched, perforated, or made of a combination of one or more of these processes, and then folded or profiled, characterized by being fully or partially perforated, being longitudinally U-shaped open at its ends, with its base positioned vertically and secured to a support structure, and having longitudinally on the edges of

both wings, perpendicular or not to the base, a series of folds with perforated sides and whose binding by engagement with the wings of the adjacent trays set forth resistant horizontal ribs which may have a rectangular, trapezoidal, triangular, etc, section, open or closed, and which, being perforated, allows the passage of air from one tray to the next along the entire facade, forming a self-ventilated facade in conjunction with the facade cladding plates that rest on those ribs.

**[0010]** None of the prior art documents shows a cladding made up of a plurality of panels, where adjacent panels have different curvatures, a first concave curvature and a second convex curvature that are used as claddings, which is easy to install on site.

**[0011]** For all the above reasons, the object of this invention is to provide a facade cladding system made up of a plurality of panels, where adjacent panels have different curvatures, a first concave curvature and a second convex curvature.

**BRIEF DESCRIPTION OF THE DRAWINGS**

**[0012]** The accompanying drawings are included to provide a greater understanding of the utility model, some of the preferred embodiments and to explain the principles of this utility model.

**[0013]** FIG. 1 shows an exploded perspective view of the elements constituting the cladding of the present utility model.

**[0014]** FIG. 2 shows a perspective view of the profile used in the cladding of the present utility model.

**[0015]** FIG. 3 shows a perspective view of a detail of the profile used in the cladding of the present utility model.

**[0016]** FIG. 4 shows a side view of the cladding of the present utility model.

**[0017]** FIG. 5 illustrates a side view of the lining of the present invention connected to a wall with standoff brackets.

**[0018]** FIGS. 6 and 6A illustrates detail perspective views of an exemplary standoff bracket used in connection with the lining of the present invention.

**DESCRIPTION OF THE INVENTION**

**[0019]** The present utility model relates to a cladding system for facades or walls that is comprised of a plurality of panels where adjacent panels have different curvatures, a first concave curvature and a second convex curvature.

**[0020]** The cladding (1) is made up of a plurality of convex panels (2) and a plurality of concave panels (3), which are alternately installed in a continuous manner, resulting in a cladding (1) with an outer surface of double curvature.

**[0021]** Each of the panels forming the plurality of convex panels (2) and concave panels (3) is installed in a first profile (4) and a second profile (5).

**[0022]** The profiles (4, 5) are formed by a first portion (6) with a "C" shape and a second portion (7) with an inverted "C" shape. The first portion (6) with a "C" shape has on the outer portion of its wings a first plurality of serrated teeth (8) and the second portion (7) with an inverted "C" shape has on the inner portion of its wings a second plurality of serrated teeth (9), which, once pushed against one another, are joined by the tongue and groove connection generated by the serrated teeth (8, 9).

**[0023]** This division of each profile (4, 5) in two portions is provided to facilitate the anchoring of said profiles (4, 5) to the wall (12). The first portion (6) with a "C" shape can be

attached to the wall (12) by screws (not shown) and the second portion (7) is then wedged in the first portion (6) through the teeth saw.

[0024] The profiles (4, 5) have at their ends of the “C” shape portion an upper groove (11) and a lower groove (10), both inclined or oblique and collinear with each other, as shown in FIG. 3.

[0025] The first profiles (4) can be rotated 180° to become second profiles (5) and the second profiles (5) can be rotated 180° to become first profiles (4).

[0026] As shown in FIG. 4, the concave curved profiles (3) are installed between a first profile (4) placed on top and a second profile (5) placed at the bottom, where both grooves, upper and lower, which support said concave curved profiles (3), are inclined towards the interior of each profile (4, 5). The convex curved panels (2) are installed between a first profile (4) placed at the bottom and a second profile (5) placed on top, where both grooves, upper and lower, which support said convex curved panels (2) are inclined toward the outside of each profile (4, 5).

[0027] As shown in FIGS. 5, 6, and 6A, the profiles (4, 5) may be connected to one or more standoff brackets (13) rather than being connected directly to the wall (12). By way of example, the standoff brackets (13) can be connected to the wall (12) and the first portions (6) can be connected to the standoff brackets (13). As discussed in greater detail below, the standoff brackets (13) can enable the panels (2, 3) to be spaced further from the wall (12) and/or increase the depth of curvature for each panel (2, 3).

[0028] According to the illustrated implementation, the standoff bracket (13) has a generally reverse C-shaped profile and includes flanges (14, 15). In the illustrated implementation, each flange (14, 15) includes a wall contacting surface (16) and an opposing exposed surface (17). As can be seen in the Figures, the flanges (14, 15) lie generally within the same plane as one another and extend away from one another and away from the generally reverse C-shaped profile portion.

[0029] The configuration and arrangement of the flanges (14, 15) may facilitate connection of the standoff bracket (13) to the wall (12). For instance, one or more fasteners (e.g., screws, nails, rivets, bolts, etc.) may extend through the flanges (14, 15) and into the wall (12) to secure the standoff bracket (13) to the wall (12). Because the flanges (14, 15) extend away from the C-shaped portion of the standoff bracket (13), an installer may have ready access to opening in the flanges (14, 15) through which such fasteners may be inserted. Additionally or alternatively, the wall contacting surfaces of the flanges (14, 15) may include surface area sufficient in size to enable the flanges (14, 15) to be secured to the wall (12) with an adhesive.

[0030] As noted, the standoff bracket (13) includes a portion having a generally C-shaped profile. More specifically, the standoff bracket (13) includes a mounting surface (18) and legs (19, 20) extending therefrom. The first portion (6) may be connected to the mounting surface (18) with one or more fasteners (e.g., screws, bolts, nuts, rivets, adhesives, clamps, etc.). In other implementations, first portions (6) and mounting surface (18) may be integrally formed.

[0031] The legs (19, 20) extend between the mounting surface (18) and the flanges (14, 15). In the illustrated implementation, the legs (19, 20) form obtuse angles with the mounting surface (18). Additionally, the distance between the legs (19, 20) changes. More specifically, the legs (19, 20) are spaced apart from one another by a first distance adjacent the

mounting surface (18) and a second, greater distance adjacent the flanges (14, 15). As a result, the standoff bracket (13) forms a channel (21). The channel (21) may enable an installer to access the back side (e.g., the side facing the wall (12)) of the mounting surface (18) to, for example, secure a nut on a bolt to connect the first portion (6) to the standoff bracket (13).

[0032] It will be appreciated that the standoff bracket is not limited to the specific implementation shown in the Figures. For instance, in other implementations, the legs extend from the mounting surface at right or acute angles. Similarly, the distance between the legs may remain constant or the distance therebetween may decrease from a first distance adjacent the mounting surface to a second, smaller distance adjacent the flanges.

[0033] As noted elsewhere herein, the standoff brackets (13) can enable the panels (2, 3) to be spaced further from the wall (12). In particular, connecting the standoff bracket (13) between the wall (12) and the first portion (6) increases the distance between the wall (12) and where the edges of the panels (2, 3) connect to the upper and lower slots (10, 11) in the second portion (7).

[0034] In addition, the inclusion of the standoff brackets (13) allows for the depth of curvature of each concave panel (3) to be increased. As can be seen in FIG. 5, the inclusion of the standoff bracket (13) allows for a concave panel (3) to have a depth of curvature ( $H_1$ ) that is substantially equal to the length ( $H_{SB}$ ) of standoff bracket (13) plus the combined length ( $H_{FSP}$ ) of the first and second portions (6, 7). In contrast, without the standoff bracket (13), a concave panel (3) is only able to have a depth of curvature that is substantially equal to the combined length ( $H_{SB}$ ) of the first and second portions (6, 7) (e.g., because the wall (12) would prevent a deeper depth of curvature for the concave panel (3)).

[0035] As can also be seen in FIGS. 5, 6, and 6A, extending between adjacent standoff brackets (13) are rear panels (22). In the illustrated implementation, the rear panels (22) are generally planar, but in other implementations, the rear panels (22) may be curved or have other configurations. The rear panels (22) may cover portions of the wall (12) between adjacent standoff brackets (13). Additionally, the rear panels (22) may provide a desired aesthetic. For instance, in cases where the panels (2, 3) are transparent or translucent, the color of the rear panels (22) may alter the perceived color of the panels (2, 3). Similarly, the rear panels (22) may provide a desired aesthetic when the wall (12) and the panels (2, 3) are viewed from an end, similar to the view shown in FIGS. 5, 6, and 6A.

[0036] The rear panels (22) may be connected directly to the wall (12) with one or more fasteners (e.g., screws, bolts, nuts, rivets, adhesives, clamps, etc.). For instance, the fasteners may extend through the rear panels (22) and into the wall (22). Alternatively or additionally, the rear panels (22) can be connected to the flanges (14, 15). For instance, one or more fasteners (e.g., screws, bolts, nuts, rivets, etc.) may pass through the rear panels (22) and the flanges (14, 15) and into the wall (12) to connect both the rear panels (22) and the flanges (14, 15) to the wall. In still other implementations, the rear panels (22) may be connected to the wall (12) such that there is a space disposed between the rear panels (22) and the wall (12). The flanges (14, 15) may fit and be securely held within the space between the rear panels (22) and the wall

(12). In any case, including those illustrated in FIGS. 5, 6, and 6A, the rear panels (22) may extend over and at least partially cover the flanges (14, 15).

[0037] Implementations of the present invention may be used in various settings. By way of example, the panels (2, 3, 22) may be mounted (e.g., via first and second portions (6, 7) and optionally standoff bracket (13)) on an exterior surface of a building to provide the building with a desired aesthetic or function. For instance, the panels (2, 3, 22) may be mounted to an exterior wall of a building to provide the building with a desired look. In other instances, the panels (2, 3, 22) may be mounted on a roof of a building to, for example, direct rain water off of the roof in a desired direction.

[0038] When used in outdoor setting, the panels (2, 3, 22) and other system components may be exposed to elements, include wind, rain, and the like. Such elements can be destructive or have other undesirable effects on the components of the system. For instance, wind may cause the panels (2, 3) to move, rattle, or even become disengaged from the upper and lower slots (10, 11).

[0039] To reduce or eliminate effects of such elements, the panels (2, 3) may have lips or ridges formed on opposing edges thereof. For instance, as can be seen in FIGS. 1, 4, 6, and 6A, opposing edges of the panels (2, 3) are folded back to form ridges (23). As illustrated in the Figures, the ridges 23 are folded back toward the convex surfaces of the panels (2, 3). In other implementations, however, the ridges may be folded toward the concave surfaces of the panels (2, 3). Accordingly, in some implementations, the ridges (23) and the surfaces of the panels (2, 3) form a generally V-, C-, or U-shaped profile. Optionally, and as shown in FIG. 6A, an insert (24) may be positioned within the ridges (23) the limit the amount of flex between the ridge (24) and the surface of the panel (2, 3). The insert (24) may be a generally circular cord and/or may have a profile that compliments the profile formed by the ridge (23) and the surface of the panel (2, 3).

[0040] In other implementations, the ridges are not folded edges of the panels (2, 3). Rather, for instance, the ridges may be molded or otherwise formed on or attached to the edges of the panels (2, 3). In such cases, the insert (24) may not be needed.

[0041] Regardless of the specific configuration of the ridges (23), when the opposing edges of the panels (2, 3) with the ridges (23) are inserted into the upper and lower slots (10, 11) (optionally with the inserts (24)), the ridges (23) may more securely engage the slots (10, 11). As a result of the secure engagement between the ridges (23) and the slots (10, 11), the panels (2, 3) can be held more securely in place and are less susceptible to the effects of the elements. By way of example, wind will be less likely to cause the panels (2, 3) to move, rattle, or become disengaged from the slots (10, 11). Similarly, the seal formed between the ridges (24) and the slots (10, 11) may limit or prevent moisture from leaking through the connection.

[0042] The various components of the present invention may be formed of various materials. For instance, the panels (2, 3, 22) may be formed of metal, resin, glass, plastic, ceramic, wood, fabric, and the like. Similarly, the first and second portions (6, 7) and the standoff bracket (13) may be formed of metal, plastic, ceramic, wood, and the like.

[0043] The present invention may be embodied in other specific forms without departing from its spirit or essential characteristics. The described embodiments are to be considered in all respects only as illustrative and not restrictive. The

scope of the invention is, therefore, indicated by the appended claims rather than by the foregoing description. All changes which come within the meaning and range of equivalency of the claims are to be embraced within their scope.

What is claimed is:

1. A cladding system for facades or walls which is composed of a plurality of panels, wherein adjacent panels have different curvatures, CHARACTERIZED in that:

said cladding (1) is made up of a plurality of convex panels (2) and a plurality of concave panels (3), which are alternately installed in a contiguous manner;

wherein each of the panels (2, 3) which form the plurality of convex panels (2) and concave panels (3) is installed on a first profile (4) and a second profile (5);

said profiles (4, 5) are formed by a first portion (6) in a "C" shape and a second portion (7) in an inverted "C" shape, wherein the first portion (6) in a "C" shape has in the outer part of its wings a first plurality of serrated teeth (8), and the second portion (7) in an inverted "C" shape has on the inside of its wings a second plurality of serrated teeth (9), which, once pushed against one another, are joined by the tongue and groove connection generated by the serrated teeth (8, 9);

wherein the first portion (6) in a "C" shape is fastened to the wall (12) with screws and the second portion (7) is then wedged in the first portion (6) through such serrated teeth;

wherein the profiles (4, 5) have at their ends of the portion in a "C" shape an upper groove (11) and a lower groove (10), both inclined or oblique and collinear with each other;

wherein the concave curved profiles (3) are installed between a first profile (4) placed on top and a second profile (5) placed at the bottom, wherein both grooves, upper and lower, which support said concave curved profiles (3) are inclined towards the interior of each profile (4, 5); and

wherein the convex curved panels (2) are installed between a first profile (4) placed at the bottom and a second profile (5) placed on top, wherein both grooves, upper and lower, which support said convex curved panels (2), are inclined toward the outside of each profile (4, 5).

2. A cladding for facades or walls according to claim 1, CHARACTERIZED in that said first profiles (4) can be rotated 180° to become second profiles (5).

3. A cladding for facades or walls according to claim 1, CHARACTERIZED in that said second profiles (5) can be rotated 180° to become first profiles (4).

4. A wall façade assembly, comprising:

a plurality of standoff brackets selectively connectable to a wall;

one or more first profile components connectable to a first standoff bracket of the plurality of standoff brackets, each of the one or more first profile components comprising:

a first portion that is connectable to the first standoff bracket; and

a second portion that is connectable to the first portion, the second portion comprising an upper slot angled away from the first portion and a lower slot angled toward the first portion;

one or more second profile components connectable to a second standoff bracket of the plurality of standoff brackets, each of the one or more second profile components comprising:

- a first portion that is connectable to the second standoff bracket; and
- a second portion that is connectable to the first portion, the second portion comprising an upper slot angled toward the first portion and a lower slot angled away from the first portion; and

one or more curved panels connected between the one or more first profile components and the one or more second profile components, each of the one or more curved panels having opposing edges that are positionable within the upper and lower slots so secure the one or more curved panels between the one or more first profile components and the one or more second profile components.

5. The wall façade assembly of claim 4, wherein, one or more of the first portions comprises one or more retention mechanisms disposed on an outer surface thereof; and one or more of the second portions comprises one or more retention mechanisms disposed on an interior surface thereof, the second portion being configured to receive at least a portion of the first portion therein, the one or more retention mechanisms of the first portion and the one or more retention mechanisms of the second portion being configured to cooperate to secure the first and second portions together.

6. The wall façade assembly of claim 4, wherein at least one standoff bracket of the plurality of standoff brackets comprises a mounting surface to which the first portion can be connected and two legs extending from the mounting surface.

7. The wall façade assembly of claim 6, wherein each of the two legs forms an obtuse angle with the mounting surface.

8. The wall façade assembly of claim 6, wherein the two legs are spaced apart a first distance adjacent the mounting surface and spaced apart a second, greater distance distant from the mounting surface.

9. The wall façade assembly of claim 6, wherein the at least one standoff bracket comprises a flange extending from an end of each leg opposite the mounting surface.

10. The wall façade assembly of claim 9, wherein the flanges facilitate connection of the at least one standoff bracket to the wall.

11. The wall façade assembly of claim 4, further comprising at least one rear panel disposed between the wall and the one or more curved panels.

12. The wall façade assembly of claim 11, wherein the at least one rear panel is connected to the wall or the plurality of standoff brackets.

13. The wall façade assembly of claim 4, wherein the one or more curved panels are formed of metal.

14. The wall façade assembly of claim 4, wherein a depth of curvature of at least one of the one or more curved panels is greater than a combined length of the first and second portions.

15. The wall façade assembly of claim 4, wherein the opposing edges of the one or more curved panels comprise ridges configured to secure the opposing edges of the one or more panels in the upper and lower slots.

16. A method of aestheticizing the exterior of a building, the method comprising:

- securing a first profile to an exterior surface of the building, the first profile comprising an upper slot angled away from the exterior surface of the building and a lower slot angled toward the exterior surface of the building;
- securing a second profile to the exterior surface of the building, the second profile comprising an upper slot angled toward the exterior surface of the building and a lower slot angled away from the exterior surface of the building; and
- connecting one or more curved panels between the first profile and the second profile.

17. The method of claim 16, wherein connecting one or more curved panels between the first profile and the second profile comprises inserting a ridge formed on a first edge of the one or more curved panels into the upper slot of the first profile and inserting a ridge formed on a second edge of the one or more curved panels in the lower slot of the second profile.

18. The method of claim 17, further comprising positioning inserts within the upper and lower slots, the inserts being configured to retain the ridges within the upper and lower slots.

19. The method of claim 16, wherein connecting one or more curved panels between the first profile and the second profile comprises inserting a ridge formed on a first edge of the one or more curved panels into the lower slot of the first profile and inserting a ridge formed on a second edge of the one or more curved panels in the upper slot of the second profile.

20. The method of claim 16, wherein the first profile is disposed below the second profile and the one or more curved panels connected therebetween are convex panels.

\* \* \* \* \*