



- (51) International Patent Classification:
H03L 3/00 (2006.01) H03B 7/06 (2006.01)
H03B 5/06 (2006.01)
- (21) International Application Number:
PCT/US2016/038465
- (22) International Filing Date:
21 June 2016 (21.06.2016)
- (25) Filing Language: English
- (26) Publication Language: English
- (30) Priority Data:
62/183,027 22 June 2015 (22.06.2015) US
15/186,034 17 June 2016 (17.06.2016) US
- (71) Applicant: MICROCHIP TECHNOLOGY INCORPORATED [US/US]; 2355 West Chandler Blvd., Chandler, Arizona 85224-6199 (US).

AO, AT, AU, AZ, BA, BB, BG, BH, BN, BR, BW, BY, BZ, CA, CH, CL, CN, CO, CR, CU, CZ, DE, DK, DM, DO, DZ, EC, EE, EG, ES, FI, GB, GD, GE, GH, GM, GT, HN, HR, HU, ID, IL, IN, IR, IS, JP, KE, KG, KN, KP, KR, KZ, LA, LC, LK, LR, LS, LU, LY, MA, MD, ME, MG, MK, MN, MW, MX, MY, MZ, NA, NG, NI, NO, NZ, OM, PA, PE, PG, PH, PL, PT, QA, RO, RS, RU, RW, SA, SC, SD, SE, SG, SK, SL, SM, ST, SV, SY, TH, TJ, TM, TN, TR, TT, TZ, UA, UG, US, UZ, VC, VN, ZA, ZM, ZW.

- (84) Designated States (unless otherwise indicated, for every kind of regional protection available): ARIPO (BW, GH, GM, KE, LR, LS, MW, MZ, NA, RW, SD, SL, ST, SZ, TZ, UG, ZM, ZW), Eurasian (AM, AZ, BY, KG, KZ, RU, TJ, TM), European (AL, AT, BE, BG, CH, CY, CZ, DE, DK, EE, ES, FI, FR, GB, GR, HR, HU, IE, IS, IT, LT, LU, LV, MC, MK, MT, NL, NO, PL, PT, RO, RS, SE, SI, SK, SM, TR), OAPI (BF, BJ, CF, CG, CI, CM, GA, GN, GQ, GW, KM, ML, MR, NE, SN, TD, TG).

- (72) Inventor: KUMAR, Ajay; 3402 East Wildwood Drive, Phoenix, Arizona 85048 (US).
- (74) Agent: SLAYDEN, Bruce W., II; Slayden Grubert Beard PLLC, 401 Congress Ave., Suite 1900, Austin, Texas 78701 (US).
- (81) Designated States (unless otherwise indicated, for every kind of national protection available): AE, AG, AL, AM,

- Declarations under Rule 4.17:**
- as to applicant's entitlement to apply for and be granted a patent (Rule 4.17(ii))
 - as to the applicant's entitlement to claim the priority of the earlier application (Rule 4.17(iii))

[Continued on next page]

(54) Title: PERIODIC KICKSTARTER FOR A CRYSTAL OSCILLATOR

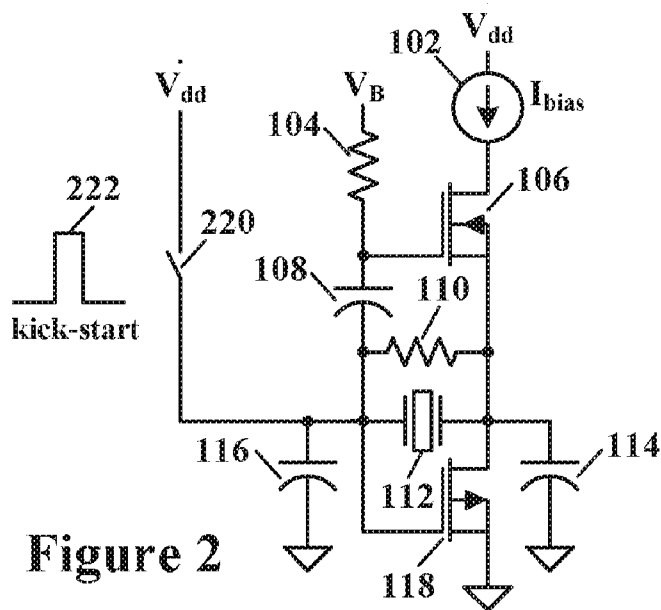

Figure 2

(57) Abstract: A cyclical pulsing oscillator having a pulse repetition rate close to a crystal resonant frequency in an oscillator provides more useful start-up energy to the crystal oscillator circuit and thus provides much faster start-up time. The start-up pulsing oscillator runs for a number of cycles or until the crystal oscillator amplitude as built up to a desired value. The pulsing oscillator may have a repetition rate of from about one-third to about one-half the crystal resonant frequency, thus providing more useful start-up energy to the crystal oscillator circuit.





Published:

— with international search report (Art. 21(3))

— before the expiration of the time limit for amending the claims and to be republished in the event of receipt of amendments (Rule 48.2(h))

PERIODIC KICKSTARTER FOR A CRYSTAL OSCILLATOR

RELATED PATENT APPLICATION

This application claims priority to commonly owned United States Provisional Patent Application Serial Number 62/183,027; filed June 22, 2015; entitled “Periodic Kickstarter for a Crystal Oscillator,” by Ajay Kumar, and is hereby incorporated by reference herein for all purposes.

TECHNICAL FIELD

The present disclosure relates to crystal oscillators in particular to a periodic kickstarter for a crystal oscillator to reduce the turn-on time of the oscillator.

BACKGROUND

Appropriately cut quartz crystals can be used as high-quality electromechanical resonators. Their piezoelectric properties (voltage across the crystal deforms it; deforming the crystal generates a voltage) allow them to be the frequency-determining element in electronic circuits. Crystals are widely used in oscillators, time bases, and frequency synthesizers for their high quality factor (QF); excellent frequency stability; tight production tolerances; and relatively low cost. All crystal oscillator circuits have a start-up time. Start-up time is an important consideration in battery-powered applications where the device is often switched on and off. Shorter oscillator start-up times reduce wasted energy in low-power systems.

The definition for the start-up time of a crystal oscillator can vary, depending on the type of system. For a microprocessor system, the start-up time is often the time from initial power application to the time a stable clock signal is available. The start-up time for a phase-locked loop (PLL) is often the time from initial power application to when a stable reference signal is available, often settled to within an acceptable frequency offset from the final steady state oscillation frequency. The start-up time of a crystal oscillator may be determined by the noise or transient conditions at turn-on; small-signal envelope expansion due to negative resistance; and large-signal amplitude limiting.

Crystal oscillators are known to have a long start-up time. Once there is a small build-up of signal which itself takes a long time, they may take additional 2,000 to 8,000 cycles to settle based on their motion arm inductance. For a 32 KHz oscillator start-up time can be over 3 to 4 seconds, and for 24-32 MHz, start-up time may extend up to 5-20 milliseconds. These long start-up times of the crystal oscillators have been reported as a problem by many users.

Kick starting of the crystal oscillator with a mono-stable one shot oscillator has been employed at equipment turn-on but has not always been successful since the energy frequency spectrum of a single pulse from a mono-stable one shot oscillator tends to fall far outside the crystal oscillation operating frequency and thus cannot add enough energy to the crystal-inductor element for quick and reliable start-up of the crystal oscillator circuit.

SUMMARY

Therefore a need exists for a way to decrease start-up time of a crystal oscillator.

According to an embodiment, an integrated oscillator configured to be coupled with an external crystal may comprise: an oscillator circuit coupled with the external crystal; and a start-up circuit may comprise a kick-start pulser coupled to the oscillator circuit and pulsing start-up energy thereto.

According to a further embodiment, the kick-start pulser may comprise a current source charging a capacitor, a discharging switch coupled in parallel with the capacitor wherein a node between the current source and the capacitor may be coupled to an input of a comparator whose output controls the discharging switch, and a pulsing switch controlled by the comparator and coupled to the oscillator circuit. According to a further embodiment, the comparator may have hysteresis. According to a further embodiment, a digital counter may disable the start-up circuit after a predetermined number of pulses generated by the start-up circuit. According to a further embodiment, the predetermined number of pulses may be from about 16 to about 32 pulses. According to a further embodiment, the predetermined number of pulses may be from about 32 to about 64 pulses.

According to a further embodiment, a frequency of the kick-start pulser may be from about one-third to about one-half of a center frequency of the external crystal. According to a further embodiment, a frequency of the kick-start pulser may be within a decade of a center frequency of the external crystal. According to a further embodiment, a frequency of the kick-start pulser may be within a bandpass frequency of the external crystal.

According to a further embodiment, a microcontroller may comprise the integrated oscillator. According to a further embodiment, the microcontroller may be configured to turn off the start-up circuit after the oscillator circuit has a stable oscillation amplitude. According to a further embodiment, the microcontroller may be configured to turn off the start-up circuit after a predetermined time period after the microcontroller starts operating.

According to a further embodiment, the oscillator circuit may comprise: a current source coupled to a supply voltage; a first resistor coupled to a bias voltage; a first capacitor coupled to the first resistor; a second resistor coupled to the first capacitor; a first transistor coupled to the current source, first capacitor, and first and second resistors; a second capacitor coupled to the first capacitor and second resistor; a third capacitor coupled to the second resistor and first transistor; a second transistor coupled to the first, second and third capacitors, the second resistor and the first transistor; and the external crystal coupled to the first and second transistors; the first, second and third capacitors; and the second resistor.

According to another embodiment, an integrated oscillator configured to be coupled with an external crystal may comprise: a crystal oscillator; a kick-start pulser coupled to the crystal oscillator; an oscillator cycle counter coupled to the crystal oscillator; and a logic gate for enabling and disabling an oscillator clock output; wherein the oscillator cycle counter may disable the kick-start pulser and may enable the oscillator clock output from the logic gate after a certain number of cycles from the oscillator may have been counted.

According to a further embodiment, the kick-start pulser may comprise a current source charging a capacitor, a discharging switch coupled in parallel with the capacitor wherein a node between the current source and the capacitor may be coupled to an input of a comparator whose output may control the discharging switch, and a pulsing switch that may be controlled by the comparator and may be coupled to the oscillator circuit. According to a further embodiment, a kick-start pulser counter may be coupled to the kick-start pulser, wherein the kick-start pulser may be disabled after a certain number of pulses that may be counted by the kick-start pulser counter. According to a further embodiment, a microcontroller may comprise the integrated oscillator.

According to yet another embodiment, an integrated oscillator configured to be coupled with an external crystal may comprise: a crystal oscillator; a kick-start pulser coupled to the crystal oscillator; a logic gate for enabling and disabling an oscillator clock output; an oscillator output amplitude detector coupled to the crystal oscillator; a voltage reference providing a reference voltage; and a voltage comparator having a first input coupled to the oscillator output amplitude detector, and a second input coupled to the voltage reference, wherein when the detected oscillator output amplitude may be greater than the reference voltage the kick-start pulser may be disabled and the logic gate may be enabled to provide the oscillator clock output.

According to a further embodiment, a kick-start pulser may comprise a current source charging a capacitor, a discharging switch coupled in parallel with the capacitor wherein a node between the current source and the capacitor may be coupled to an input of a comparator whose output controls the discharging switch, and a pulsing switch controlled by the comparator and coupled to the oscillator circuit. According to a further embodiment, a microcontroller may comprise the integrated oscillator.

According to still another embodiment, a method for starting an integrated oscillator configured to be coupled with an external crystal may comprise the steps of: coupling an oscillator circuit to the external crystal; and pulsing energy into the oscillator circuit with a kick-start pulser coupled thereto. According to a further embodiment of the method, the step of pulsing energy into the kick-start pulser may comprise the steps of: charging a capacitor with a current source; discharging the capacitor with a switch that may be controlled by a comparator that has hysteresis when a voltage on the capacitor may be reached; and switching on and off a pulsing switch with the comparator, wherein the pulsing switch provides the pulsing energy to the oscillator circuit.

BRIEF DESCRIPTION OF THE DRAWINGS

A more complete understanding of the present disclosure may be acquired by referring to the following description taken in conjunction with the accompanying drawings wherein:

Figure 1 illustrates a schematic diagram of a crystal oscillator circuit;

Figure 2 illustrates a schematic diagram of a crystal oscillator having a single pulse kick-start circuit;

Figure 3 illustrates a schematic frequency-amplitude graph of a crystal;

Figure 4 illustrates a schematic circuit and block diagram of a crystal oscillator having a periodic kickstarter, according to a specific example embodiment of this disclosure;

Figure 5 illustrates a schematic circuit and block diagram of a crystal oscillator having a periodic kickstarter, according to another specific example embodiment of this disclosure;

Figure 6 illustrates a schematic circuit and block diagram of a crystal oscillator having a periodic kickstarter, according to yet another specific example embodiment of this disclosure;

Figure 7 illustrates a schematic frequency-amplitude graph of a crystal showing kick-start pulses within the frequency bandwidth of the crystal, according to the teachings of this disclosure;

Figure 8 illustrates schematic frequency-amplitude graphs of the start-up of a crystal oscillator using kick-start pulses within the frequency bandwidth of the crystal, according to the teachings of this disclosure;

Figure 9 illustrates a schematic diagram of a crystal oscillator output amplitude level detector for enabling/disabling a kick-start pulser, according to the specific example embodiment shown in Figure 6;

Figure 10 illustrates a schematic diagram of a kick-start pulser circuit, according to specific example embodiments of this disclosure; and

Figure 11 illustrates a schematic block diagram of a microcontroller comprising the crystal oscillator circuit shown in Figures 4, 5 or 6, according to the teachings of this disclosure.

While the present disclosure is susceptible to various modifications and alternative forms, specific example embodiments thereof have been shown in the drawings and are herein described in detail. It should be understood, however, that the description herein of specific example embodiments is not intended to limit the disclosure to the particular forms disclosed herein.

DETAILED DESCRIPTION

According to various embodiments of this disclosure, a pulsing oscillator having a pulse repetition rate close to the crystal oscillator resonant frequency provides more useful start-up energy to the crystal oscillator circuit and thus provides a much faster start-up time. The start-up pulsing oscillator may run, for example but is not limited to, 16 to 64 pulses, or until the crystal oscillator amplitude has built up to a desired value.

Referring now to the drawings, the details of example embodiments are schematically illustrated. Like elements in the drawings will be represented by like numbers, and similar elements will be represented by like numbers with a different lower case letter suffix.

Referring to Figure 1, depicted is a schematic diagram of a crystal oscillator circuit. This crystal oscillator circuit, generally referenced by the numeral 100, may comprise a current source 102, a first resistor 104, a P-Channel metal oxide semiconductor (PMOS) field effect

transistor (FET) 106, a first capacitor 108, a second resistor 110, a crystal frequency determining element 112, a second capacitor 114, a third capacitor 116, and an NMOS FET 118 configured in a totem pole circuit configuration with the PMOS FET 106. The crystal oscillator circuit 100 depends on circuit noise energy to start up its oscillation, and takes the longest time to come up to full operational oscillation output. A crystal oscillator circuit 100 oscillating at 32 KHz may take up to three to four seconds to start-up, and a 32 MHz oscillator may take about 5 to 20 milliseconds for start-up.

This is a standard crystal oscillator circuit design, and one having ordinary skill in electronic circuit design and the benefit of this disclosure could easily come up with other crystal oscillator circuit designs that work equally well. All of these other crystal oscillator circuits are applicable to this disclosure and are contemplated herein.

Referring to Figure 2, depicted is a schematic diagram of a crystal oscillator having a single pulse kick-start circuit. This is the same crystal oscillator circuit 100 as shown in Figure 1 but has a kick-start input comprising a kick-start switch 220 that provides energy with a single pulse 222 to the crystal oscillator circuit 100. This single pulse 222 has very little energy that is useful in starting up the crystal oscillator circuit 100 because it has a wide frequency spectrum with very little energy content within the crystal bandwidth. Only a small portion of the energy from this pulse will fall within the crystal bandwidth range as shown in Figure 3. Also the energy in a single kick-start pulse is an inverse functional of frequency, thus the higher the frequency of the oscillator the lower the effectiveness will be of the single kick-starter circuit. Simulations have shown that the crystal oscillator of Figure 2 may take from about 2,000 to 8,000 cycles after a single pulse 222 kick-start. Parasitic circuit capacitances also may attenuate energy from the single pulse and sometimes the crystal oscillator may not start-up at all.

Referring to Figure 4, depicted is a schematic circuit and block diagram of a crystal oscillator having a periodic kickstarter, according to a specific example embodiment of this disclosure. This crystal oscillator having a periodic kickstarter, generally represented by the numeral 400, may comprise a crystal oscillator circuit 100, a kick-start pulser 434, inverters 438 and 440, an oscillator counter 442 and an AND gate 444. The kick-start pulser 434 may have a pulse repetition rate (frequency) of from about one-third to about one-half the center frequency of the crystal 112. These repetition rates may provide substantial energy to the crystal

oscillator circuit 100, and this periodic signal with its fundamental and harmonic frequencies can excite the crystal oscillator circuit 100. It is contemplated and within the scope of this disclosure that a pulser kicking frequency may be within a decade of the center-frequency of the crystal and be effective with the specific example embodiments of this disclosure.

5 The crystal oscillator circuit 100 may be pulsed, for example but is not limited to, 16-32 times with the kick-start pulser 434 thereby feeding a substantial amount of energy into the frequency band-pass range of the crystal 112 as shown in Figure 7. The kick-start pulser 434 provides a periodic signal that effectively excites with its fundamental and harmonic energy the L-C tank circuit of the crystal 112. Typically the crystal oscillator with periodic kick-start
10 400 may start over ten times faster than just the crystal oscillator circuit 100 without any pulse excitation. A crystal oscillator requires a smaller gm to maintain oscillation once crystal oscillation has been established. Therefore, a higher energy kick-starter will allow the crystal oscillator to run at lower power.

 The oscillator counter 442 monitors the number of cycles from the time that the crystal
15 oscillator circuit 100 has enough output voltage amplitude to drive the inverter 438. When a sufficient number of cycles, *e.g.*, 2048 or 4096, have been counted by the oscillator counter 442, its overflow output will enable the oscillator clock from the output of the AND gate 444, and disable the kick-start pulser 434. Reset of the counter 442 may be done with a power-on-reset or external reset command (not shown).

20 Figure 8 shows schematic frequency-amplitude graphs of the start-up of a crystal oscillator using kick-start pulses within the frequency bandwidth of the crystal versus no kick-start pulses (lower graph). A faster output amplitude increase is depicted for the crystal oscillator output amplitude (upper graph) with the periodic pulses from the kick start pulser 434.

25 Referring to Figure 5, depicted is a schematic circuit and block diagram of a crystal oscillator having a periodic kickstarter, according to another specific example embodiment of this disclosure. This crystal oscillator having a periodic kickstarter, generally represented by the numeral 500, may comprise a crystal oscillator circuit 100, a kick-start pulser 434, inverters 438 and 440, an oscillator counter 442, an AND gate 444, and a kick-start pulser counter 536.
30 The crystal oscillator 500 works in substantially the same as the crystal oscillator 400 described

hereinabove. However, a kick-start pulser counter 536 has been added to limit the number of pulses from the kick-start pulser 434, for example but not limited to 64.

Referring to Figure 6, depicted is a schematic circuit and block diagram of a crystal oscillator having a periodic kickstarter, according to yet another specific example embodiment of this disclosure. This crystal oscillator having a periodic kickstarter, generally represented by the numeral 600, may comprise a crystal oscillator circuit 100, a kick-start pulser 434, inverters 438, 440 and 656, an AND gate 444, an oscillator output amplitude to DC level converter 654, a voltage comparator 650 and a voltage reference 652. The crystal oscillator 600 works in substantially the same way as do the crystal oscillators 400 and 500 regarding excitation from the kick-start pulser 434 as described more fully hereinabove. However instead of counting the number of kick-start pulses and/or oscillator startup cycles, a simple peak voltage detector is provided so that when the output amplitude of the crystal oscillator circuit 100 reaches a desired amplitude value the kick-start pulser 434 is disabled and the oscillator clock output from the AND gate 444 is enabled. With this peak detector circuit of Figure 6 the kick-start pulser 434 will be disabled as soon as the desired output amplitude from the crystal oscillator circuit 100 is achieved, and the oscillator clock output from the AND gate 444 will be enabled. Also if the output amplitude of the crystal oscillator circuit 100 should become less than the desired amplitude value, then the kick-start pulser 434 may be re-enabled and the oscillator clock from the output of AND gate 444 inhibited (disabled).

Referring to Figure 9, depicted is a schematic diagram of a crystal oscillator output amplitude level detector and enable/disable circuit for a kick-start pulser according to the specific example embodiment shown in Figure 6. A simple diode rectifier 654 or an envelope detector circuit may be used to rectify the high frequency oscillator waveform and provide a DC voltage level representative of the amplitude of the oscillator output waveform. A RC low pass filter may be coupled between the output of the diode rectifier 654 and a first input of the voltage comparator 650. A second input of the voltage comparator 650 is coupled to the voltage reference 652. In the circuit configuration shown in Figure 9, whenever the voltage on the first input (+) is greater than a reference voltage from the voltage reference 652 the output thereof goes to a logic high, and may be used to enable the clock oscillator output from the AND gate 444 and disable the kick-start pulser 434.

Referring to Figure 10, depicted is a schematic diagram of a kick-start pulser circuit, according to specific example embodiments of this disclosure. The kick-start pulser 434 may comprise a current source 1060, a timing capacitor 1062, switches 1064 and 1068, and a comparator 1066 with hysteresis. As the current source 1060 charges the capacitor 1062 the voltage rises across its plates. The voltage across the capacitor 1062 is sensed by the comparator 1066. When the voltage crosses the threshold voltage of the comparator 1066 its output changes logic levels which in turn controls the switch 1064 connected across the two plates of the capacitor 1062. When the output of the comparator 1066 goes to a logic low it enables (closes) the switch 1064 across the capacitor 1062 and shorts the two plates of the capacitor 1062 together, thereby removing any voltage difference therebetween. With the voltage across the plates of the capacitor 1062 drops to substantially zero volts the comparator 1066 output returns to a logic high and disables (opens) the switch 1064 across the capacitor 1062, thereby allowing the current source 1060 to begin charging a voltage on the capacitor 1062 again. This charging and discharging of capacitor 1062 creates a periodic wave form which is used to pulse the crystal oscillator circuit 434. The kick-start pulser 434 circuit shown in Figure 10 is representative of a clock generator circuit. One skill in the art of electronic circuit design and having the benefit of this disclosure may readily come-up with several different designs of circuits that create periodic waveforms that may be used with the kick-start circuits described in this disclosure.

Referring to Figure 11, depicted is a schematic block diagram of a microcontroller comprising the crystal oscillator circuit shown in Figures 4, 5 or 6, according to the teachings of this disclosure. A microcontroller 1102 may comprise a digital processor and memory 1104, peripheral modules 1106, input/output 1108 and a clock oscillator 400, 500 or 600. The crystal oscillator embodiments disclosed herein allow the microcontroller 1102 to start operation sooner since a clock oscillator output will be available and stable in less time than if no kick-start pulser 434 is provided with the crystal oscillator circuit.

CLAIMS

1. An integrated oscillator configured to be coupled with an external crystal, comprising:
an oscillator circuit coupled with the external crystal; and
5 a start-up circuit comprising a kick-start pulser coupled to the oscillator circuit and pulsing start-up energy thereto.
2. The integrated oscillator according to claim 1, wherein the kick-start pulser comprises a current source charging a capacitor, a discharging switch coupled in parallel with the capacitor wherein a node between the current source and the capacitor is coupled to an
10 input of a comparator whose output controls the discharging switch, and a pulsing switch controlled by the comparator and coupled to the oscillator circuit.
3. The integrated oscillator according to claim 1 or claim 2, wherein the comparator has hysteresis.
4. The integrated oscillator according to one of the preceding claims, further
15 comprising a digital counter which disables the start-up circuit after a predetermined number of pulses generated by the start-up circuit.
5. The integrated oscillator according to one of the preceding claims, wherein the predetermined number of pulses is from about 16 to about 32 pulses.
6. The integrated oscillator according to one of the preceding claims, wherein the
20 predetermined number of pulses is from about 32 to about 64 pulses.
7. The integrated oscillator according to one of the preceding claims, wherein a frequency of the kick-start pulser is from about one-third to about one-half of a center frequency of the external crystal.
8. The integrated oscillator according to one of the preceding claims, wherein a
25 frequency of the kick-start pulser is within a decade of a center frequency of the external crystal.

9. The integrated oscillator according to one of the preceding claims, wherein a frequency of the kick-start pulser is within a bandpass frequency of the external crystal.

10. A microcontroller comprising the integrated oscillator according to one of the preceding claims.

5 11. The microcontroller according to claim 10, wherein the microcontroller is configured to turn off the start-up circuit after the oscillator circuit has a stable oscillation amplitude.

12. The microcontroller according to claim 10, wherein the microcontroller is configured to turn off the start-up circuit after a predetermined time period after the
10 microcontroller starts operating.

13. The integrated oscillator according to one of the preceding claims, wherein the oscillator circuit comprises:

a current source coupled to a supply voltage;

a first resistor coupled to a bias voltage;

15 a first capacitor coupled to the first resistor;

a second resistor coupled to the first capacitor;

a first transistor coupled to the current source, first capacitor, and first and second resistors;

a second capacitor coupled to the first capacitor and second resistor;

20 a third capacitor coupled to the second resistor and first transistor;

a second transistor coupled to the first, second and third capacitors, the second resistor and the first transistor; and

the external crystal coupled to the first and second transistors; the first, second and third capacitors; and the second resistor.

25

14. An integrated oscillator configured to be coupled with an external crystal, comprising:

a crystal oscillator;

a kick-start pulser coupled to the crystal oscillator;

5 an oscillator cycle counter coupled to the crystal oscillator; and

a logic gate for enabling and disabling an oscillator clock output;

wherein the oscillator cycle counter will disable the kick-start pulser and enable the oscillator clock output from the logic gate after a certain number of cycles from the oscillator are counted.

10 15. The integrated oscillator according to claim 14, wherein the kick-start pulser comprises a current source charging a capacitor, a discharging switch coupled in parallel with the capacitor wherein a node between the current source and the capacitor is coupled to an input of a comparator whose output controls the discharging switch, and a pulsing switch controlled by the comparator and coupled to the oscillator circuit.

15 16. The integrated oscillator according to claim 14 or claim 15, further comprising a kick-start pulser counter coupled to the kick-start pulser, wherein the kick-start pulser will be disabled after a certain number of pulses are counted by the kick-start pulser counter.

17. A microcontroller comprising the integrated oscillator according to one of claims 14 - 16.

18. An integrated oscillator configured to be coupled with an external crystal, comprising:

a crystal oscillator;

a kick-start pulser coupled to the crystal oscillator;

5 a logic gate for enabling and disabling an oscillator clock output;

an oscillator output amplitude detector coupled to the crystal oscillator;

a voltage reference providing a reference voltage; and

10 a voltage comparator having a first input coupled to the oscillator output amplitude detector, and a second input coupled to the voltage reference, wherein when the detected oscillator output amplitude is greater than the reference voltage the kick-start pulser is disabled and the logic gate is enabled to provide the oscillator clock output.

19. The integrated oscillator according to claim 18, wherein the kick-start pulser comprises a current source charging a capacitor, a discharging switch coupled in parallel with
15 the capacitor wherein a node between the current source and the capacitor is coupled to an input of a comparator whose output controls the discharging switch, and a pulsing switch controlled by the comparator and coupled to the oscillator circuit.

20. A microcontroller comprising the integrated oscillator according to claim 18 or claim 19.

20 21. A method for starting an integrated oscillator configured to be coupled with an external crystal, said method comprising the steps of:

coupling an oscillator circuit to the external crystal; and

pulsing energy into the oscillator circuit with a kick-start pulser coupled thereto.

22. The method according to claim 21, wherein the step of pulsing energy into the
25 kick-start pulser comprises the steps of:

charging a capacitor with a current source;

discharging the capacitor with a switch that is controlled by a comparator that has hysteresis when a voltage on the capacitor is reached; and

30 switching on and off a pulsing switch with the comparator, wherein the pulsing switch provides the pulsing energy to the oscillator circuit.

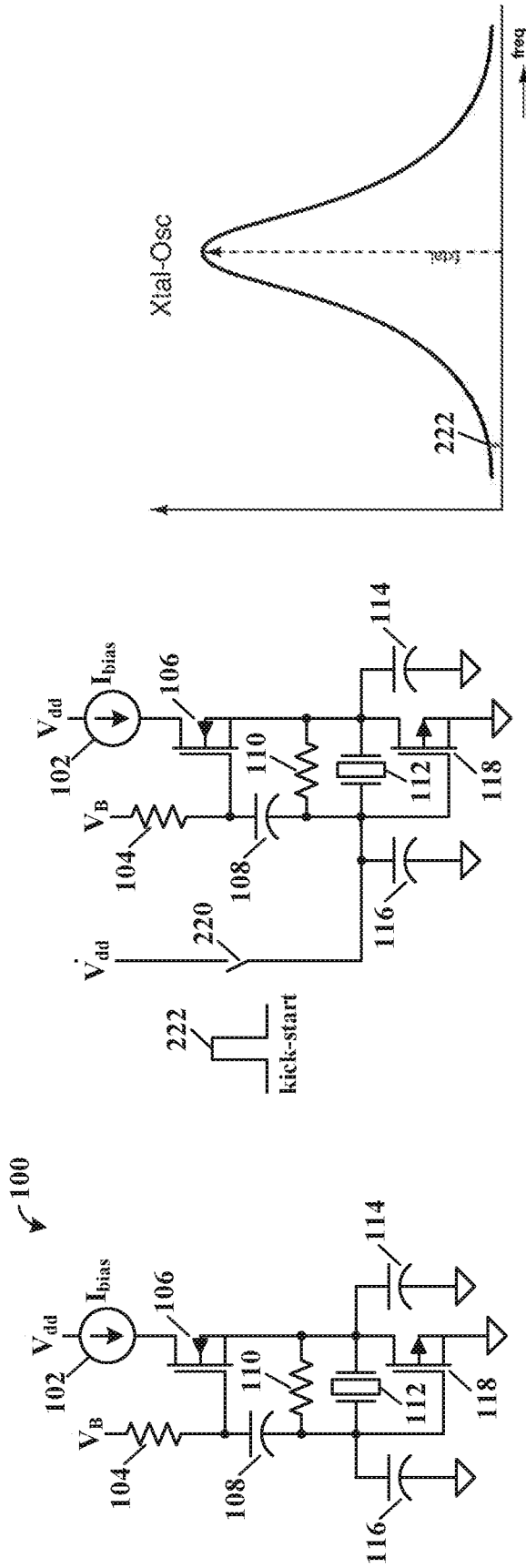

Figure 1

Figure 2

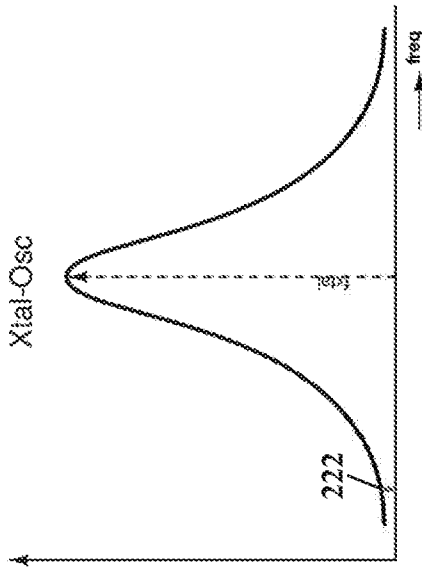

Figure 3

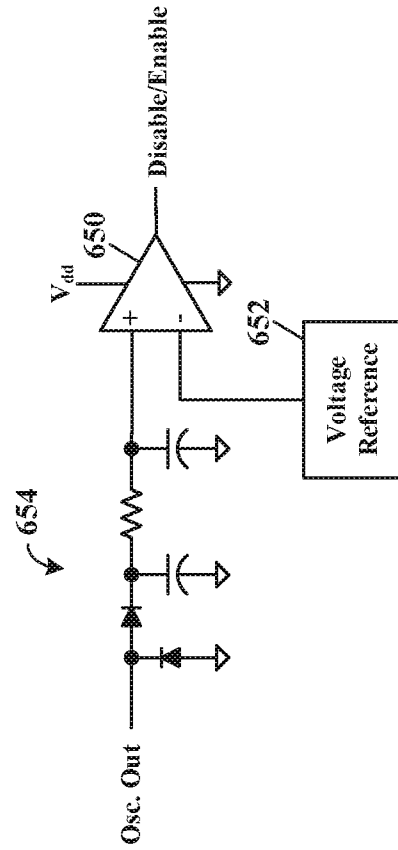

Figure 9

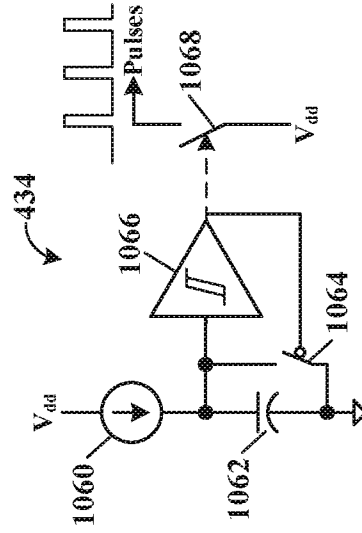

Figure 10

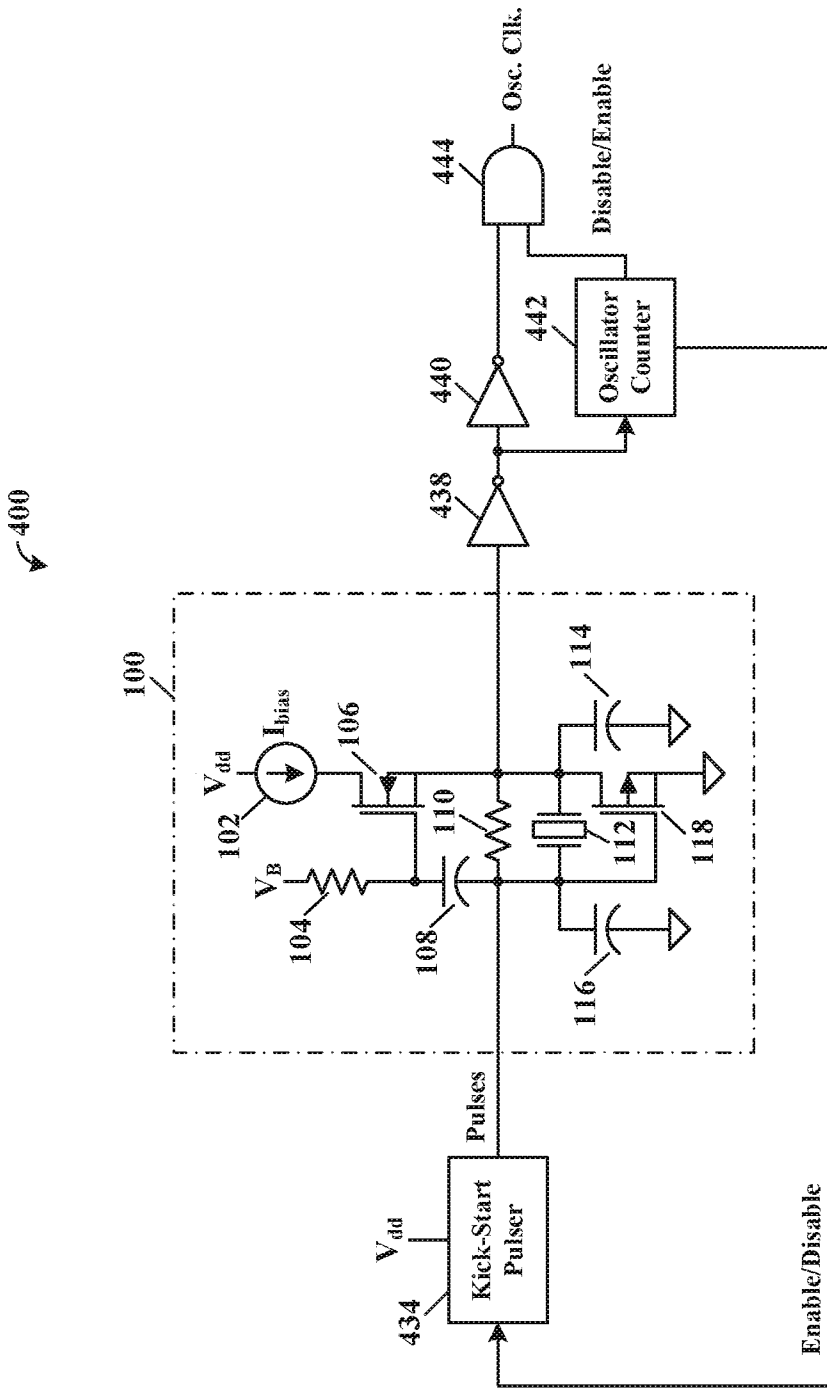

Figure 4

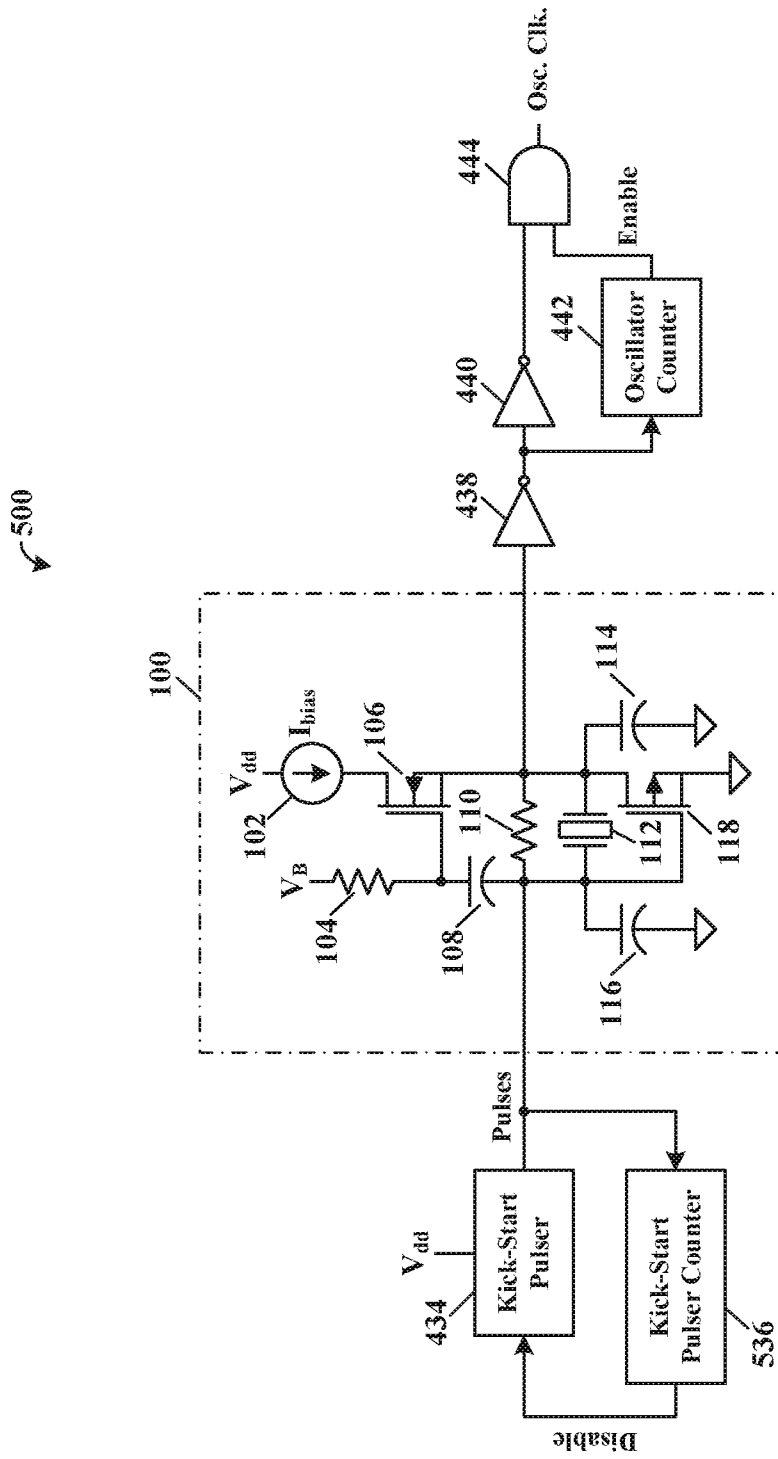

Figure 5

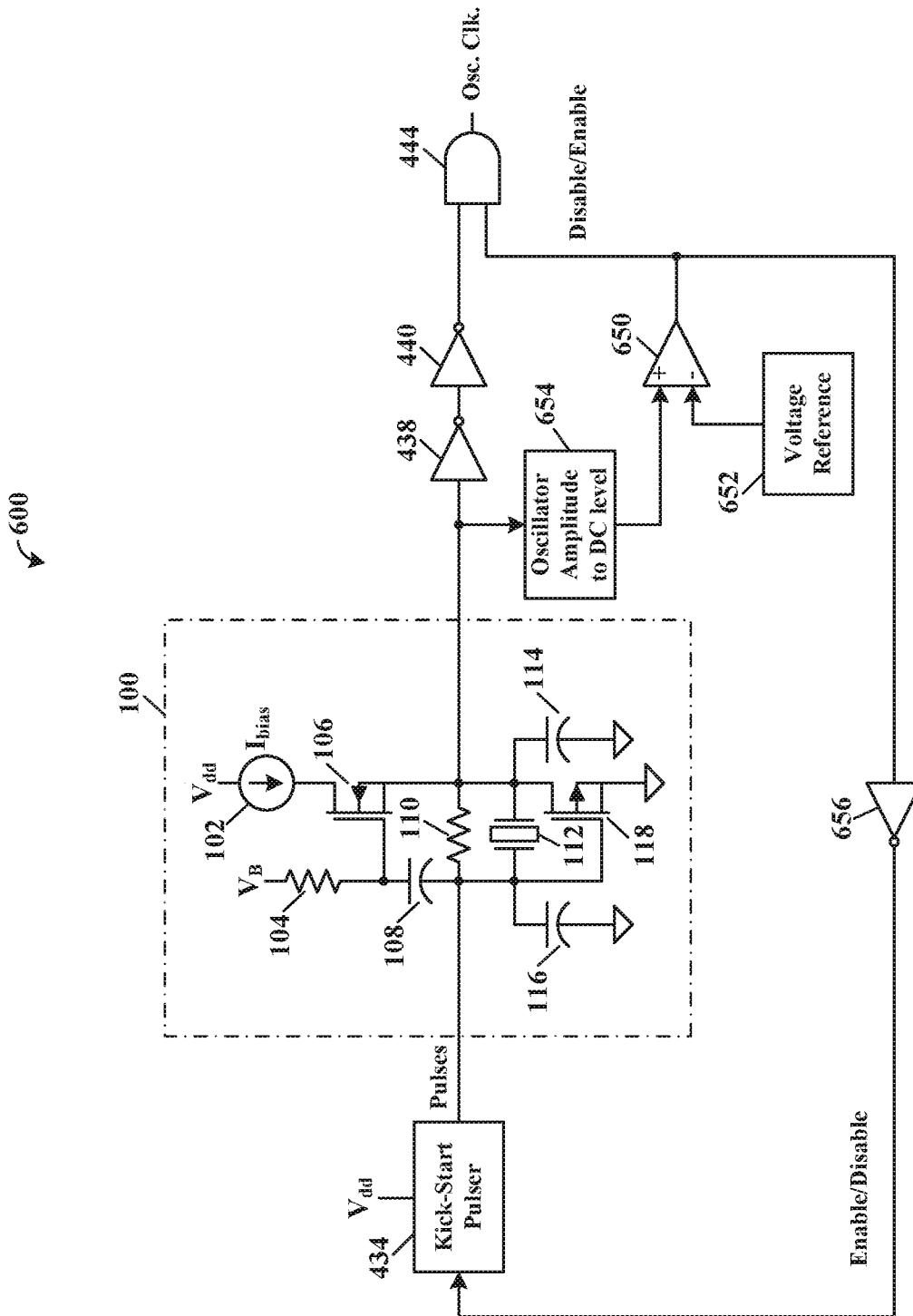

Figure 6

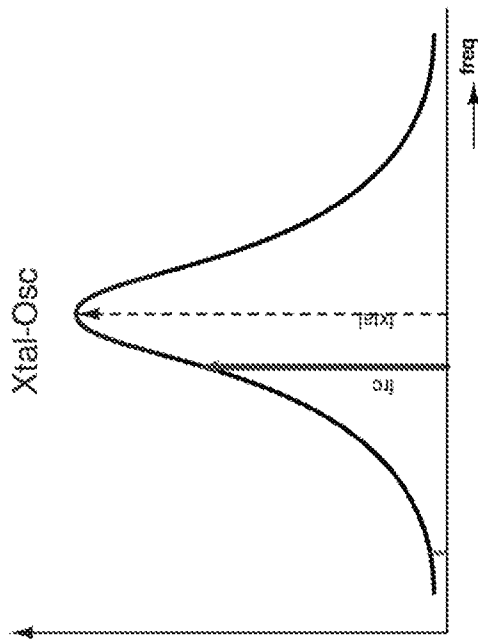

Figure 7

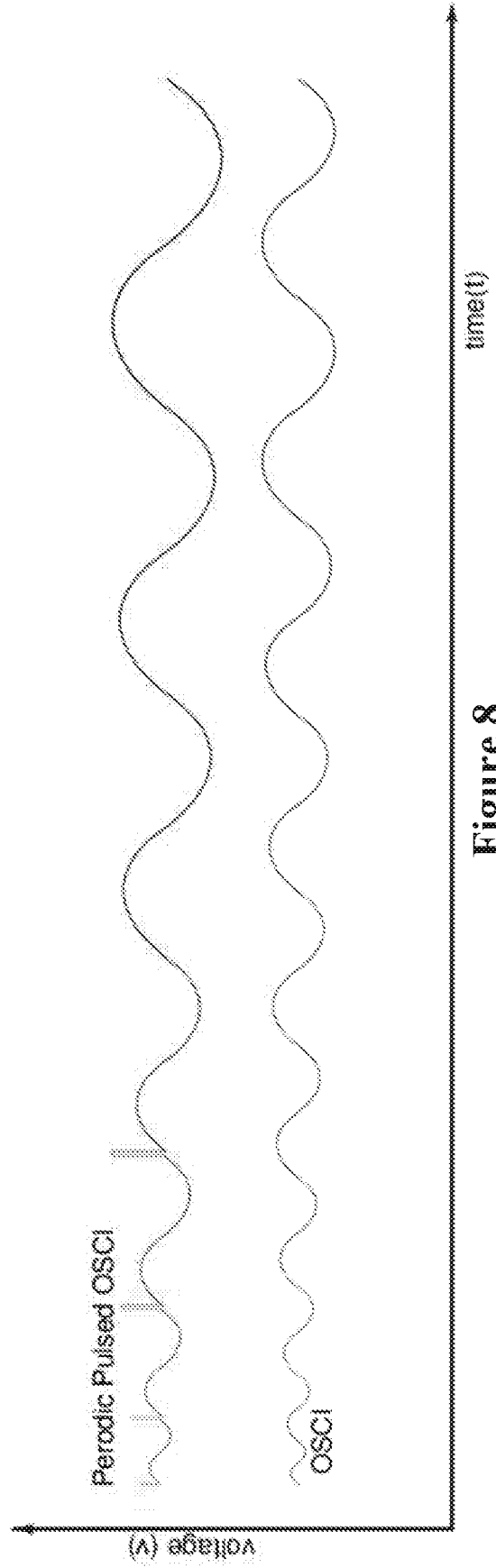

Figure 8

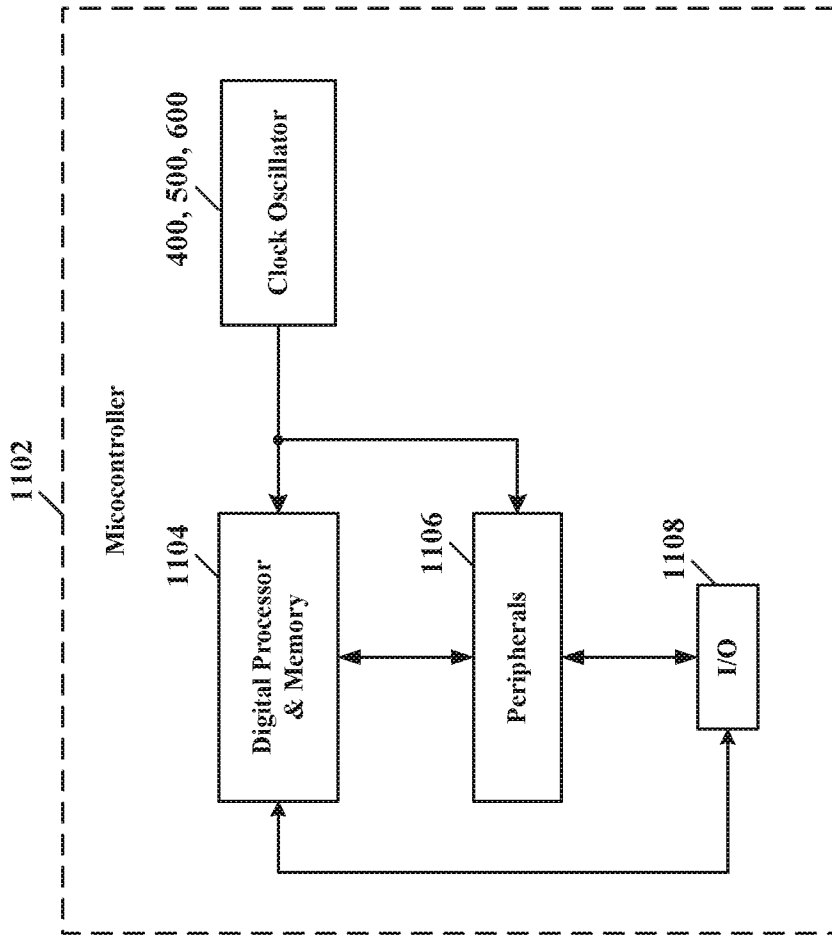

Figure 11

INTERNATIONAL SEARCH REPORT

International application No
PCT/US2016/038465

A. CLASSIFICATION OF SUBJECT MATTER
INV. H03L3/00 H03B5/06 H03B7/06
ADD.
According to International Patent Classification (IPC) or to both national classification and IPC

B. FIELDS SEARCHED
Minimum documentation searched (classification system followed by classification symbols)
H03L H03B H03K
Documentation searched other than minimum documentation to the extent that such documents are included in the fields searched

Electronic data base consulted during the international search (name of data base and, where practicable, search terms used)
EPO-Internal, WPI Data

C. DOCUMENTS CONSIDERED TO BE RELEVANT		
Category*	Citation of document, with indication, where appropriate, of the relevant passages	Relevant to claim No.
X	US 7 425 852 B2 (GARZAROLLI MATTHIAS [DE] ET AL) 16 September 2008 (2008-09-16) column 6, line 17 - column 8, line 11; figures 2,3	1-22
X	----- US 2005/083139 A1 (GAZIT MEIR [IL]) 21 April 2005 (2005-04-21) paragraph [0021] - paragraph [0027]; figures 3-5	1-13,21, 22
X	----- US 2008/042755 A1 (FEYGIN GENNADY [US] ET AL) 21 February 2008 (2008-02-21) column 18 column 22 - column 31; figure 2 ----- -/--	1-13,21, 22

Further documents are listed in the continuation of Box C. See patent family annex.

* Special categories of cited documents :

"A" document defining the general state of the art which is not considered to be of particular relevance	"T" later document published after the international filing date or priority date and not in conflict with the application but cited to understand the principle or theory underlying the invention
"E" earlier application or patent but published on or after the international filing date	"X" document of particular relevance; the claimed invention cannot be considered novel or cannot be considered to involve an inventive step when the document is taken alone
"L" document which may throw doubts on priority claim(s) or which is cited to establish the publication date of another citation or other special reason (as specified)	"Y" document of particular relevance; the claimed invention cannot be considered to involve an inventive step when the document is combined with one or more other such documents, such combination being obvious to a person skilled in the art
"O" document referring to an oral disclosure, use, exhibition or other means	"&" document member of the same patent family
"P" document published prior to the international filing date but later than the priority date claimed	

Date of the actual completion of the international search 21 October 2016	Date of mailing of the international search report 31/10/2016
---	---

Name and mailing address of the ISA/ European Patent Office, P.B. 5818 Patentlaan 2 NL - 2280 HV Rijswijk Tel. (+31-70) 340-2040, Fax: (+31-70) 340-3016	Authorized officer Aouichi, Mohamed
--	---

INTERNATIONAL SEARCH REPORT

International application No
PCT/US2016/038465

C(Continuation). DOCUMENTS CONSIDERED TO BE RELEVANT		
Category*	Citation of document, with indication, where appropriate, of the relevant passages	Relevant to claim No.
A	ZHIGE ZOU ET AL: "A novel schmitt trigger with low temperature coefficient", CIRCUITS AND SYSTEMS, 2008. APCCAS 2008. IEEE ASIA PACIFIC CONFERENCE ON, IEEE, PISCATAWAY, NJ, USA, 30 November 2008 (2008-11-30), pages 1398-1401, XP031405264, DOI: 10.1109/APCCAS.2008.4746291 ISBN: 978-1-4244-2341-5 C. Application; page 1399 - page 1400; figure 3 -----	2-12, 15-17, 19,20,22
A	URS DENIER: "Analysis and Design of an Ultralow-Power CMOS Relaxation Oscillator", IEEE TRANSACTIONS ON CIRCUITS AND SYSTEMS I: REGULAR PAPERS, IEEE, US, vol. 57, no. 8, 1 August 2010 (2010-08-01) , pages 1973-1982, XP011333761, ISSN: 1549-8328, DOI: 10.1109/TCSI.2010.2041504 II. Circuit Description; page 1974; figure 1 -----	2-12, 15-17, 19,20,22
A	US 8 643 445 B1 (SAMALA SREEKIRAN [US]) 4 February 2014 (2014-02-04) column 1, line 48 - column 4, line 20; figure 1 -----	13

INTERNATIONAL SEARCH REPORT

Information on patent family members

International application No

PCT/US2016/038465

Patent document cited in search report	Publication date	Patent family member(s)	Publication date
US 7425852	B2	16-09-2008	AT 426947 T 15-04-2009
			DE 102006009644 A1 05-07-2007
			EP 1806848 A1 11-07-2007
			US 2007153953 A1 05-07-2007

US 2005083139	A1	21-04-2005	AU 2003274640 A1 04-05-2004
			US 2005083139 A1 21-04-2005
			WO 2004036733 A2 29-04-2004

US 2008042755	A1	21-02-2008	NONE

US 8643445	B1	04-02-2014	NONE
