

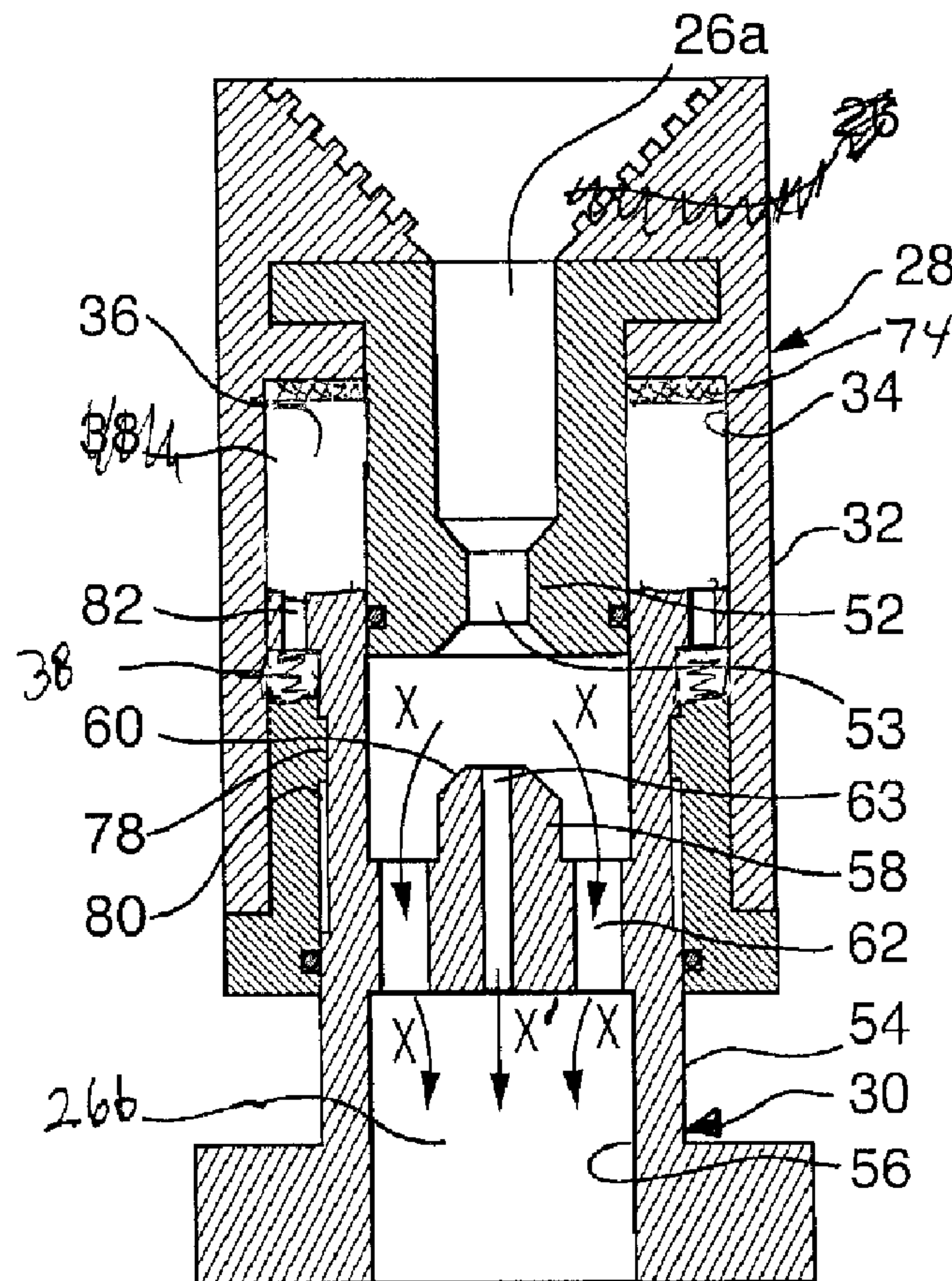

(22) Date de dépôt/Filing Date: 2013/03/14
(41) Mise à la disp. pub./Open to Public Insp.: 2014/04/15
(30) Priorités/Priorities: 2012/10/15 (US61/714,040);
2012/11/29 (US61/731,308)

(51) Cl.Int./Int.Cl. *E21B 7/24* (2006.01)
(71) Demandeur/Applicant:
BBJ TOOLS INC., CA
(72) Inventeur/Inventor:
COTE, BRADLEY R., CA
(74) Agent: BENNETT JONES LLP

(54) Titre : SOUS-ENSEMBLE D'AGITATEUR
(54) Title: AGITATOR SUB



(57) Abrégé/Abstract:

A hydraulically driven agitator sub includes: a tubular body for connection within a string including a first mandrel and a second mandrel, and a central bore defining a longitudinal axis of the tubular body and creating a flow path permitting a flow of fluids



(57) **Abrégé(suite)/Abstract(continued):**

between the two mandrels and through the tubular body, the second mandrel secured, at least partially, within an annular bore of the first mandrel so that the second mandrel is telescopically arranged with and axially moveable within the first mandrel between a telescopically extended position and a compressed position; and a first sealing part and a second sealing part, one of the first and the second sealing part being secured to the first mandrel and the other sealing part being secured to the second mandrel, both sealing parts being within the fluid flow path of the tubular body, the first sealing part and the second sealing part being positioned to come together when the first mandrel and the second mandrel are in the compressed position to form a seal in the fluid path, the seal substantially preventing the flow of fluids through the tubular body.

Abstract

A hydraulically driven agitator sub includes: a tubular body for connection within a string including a first mandrel and a second mandrel, and a central bore defining a longitudinal axis of the tubular body and creating a flow path permitting a flow of fluids between the two mandrels and through the tubular body, the second mandrel secured, at least partially, within an annular bore of the first mandrel so that the second mandrel is telescopically arranged with and axially moveable within the first mandrel between a telescopically extended position and a compressed position; and a first sealing part and a second sealing part, one of the first and the second sealing part being secured to the first mandrel and the other sealing part being secured to the second mandrel, both sealing parts being within the fluid flow path of the tubular body, the first sealing part and the second sealing part being positioned to come together when the first mandrel and the second mandrel are in the compressed position to form a seal in the fluid path, the seal substantially preventing the flow of fluids through the tubular body.

AGITATOR SUB

FIELD

The present invention relates to an apparatus and method for creating an agitation effect in a string.

5 BACKGROUND

Agitators are employed to facilitate wellbore drilling and installation of wellbore liners. Agitators create a regular movement of the string that enhances advancement of the drill bit and prevents slip stick in a well string such as a liner.

SUMMARY

10 In accordance with a broad aspect of the present invention there is provided an apparatus comprising: a tubular body for connection within a string including a first mandrel and a second mandrel, and a central bore defining a longitudinal axis of the tubular body and creating a flow path permitting a flow of fluids between the two mandrels and through the tubular body, the second mandrel secured, at least partially, within an annular bore of the first mandrel so that
15 second mandrel is telescopically arranged with and axially moveable within the first mandrel between a telescopically extended position and a compressed position; and a first sealing part and a second sealing part, one of the first and the second sealing part being secured to the first mandrel and the other sealing part being secured to the second mandrel, both sealing parts being within the fluid flow path of the tubular body, the first sealing part and the second sealing part
20 being positioned to come together when the first mandrel and the second mandrel are in a fully compressed position to form a seal in the fluid flow path, the seal preventing the flow of fluids through the tubular body.

In accordance with another broad aspect of the present invention there is provided a drill string comprising: a string of tubulars; a drill bit connected at a distal end of the string of tubulars; a
25 drill collar; and a hydraulically driven agitator positioned between the drill bit and the drill collar.

In accordance with another broad aspect of the present invention there is provided a method for creating an agitation effect in a wellstring, the method comprising: connecting an apparatus as above in-line with a wellbore string to position the second mandrel and the first mandrel in the compressed position when there is weight on bit in the wellbore string; applying weight on bit to
5 position the first mandrel and the second mandrel in the fully compressed position; pumping fluids through the wellbore string to develop a fluid pressure overcoming the weight on bit holding the first mandrel and the second mandrel in compressed position and driving the first mandrel and the second mandrel apart; allowing the pressure to dissipate such that the first mandrel and the second mandrel return back to the compressed position; and continuing to pump
10 fluids through the wellbore string to create an agitation effect as the first mandrel and the second mandrel continue to be pumped apart and then returned to the compressed position.

It is to be understood that other aspects of the present invention will become readily apparent to those skilled in the art from the following detailed description, wherein various embodiments of the invention are shown and described by way of illustration. As will be realized, the invention
15 is capable for other and different embodiments and its several details are capable of modification in various other respects, all without departing from the spirit and scope of the present invention. Accordingly the drawings and detailed description are to be regarded as illustrative in nature and not as restrictive.

BRIEF DESCRIPTION OF THE DRAWINGS

20 Referring to the drawings, several aspects of the present invention are illustrated by way of example, and not by way of limitation, in detail in the Figures, wherein:

Figure 1 is a schematic representation of a typical well bore drilling scenario with one embodiment of the apparatus connected in-line with a string.

Figure 2A is a side elevation, sectional view of one embodiment of the apparatus in an extended
25 position.

Figure 2B is a side elevation, sectional view of one embodiment of the apparatus in a sealing position.

DESCRIPTION OF VARIOUS EMBODIMENTS

The detailed description set forth below in connection with the appended drawings is intended as a description of various embodiments of the present invention and is not intended to represent the only embodiments contemplated by the inventor. The detailed description includes specific
5 details for the purpose of providing a comprehensive understanding of the present invention. However, it will be apparent to those skilled in the art that the present invention may be practiced without these specific details.

For the sake of clarity, within this description, the terms "up", "uphole", "upper", "above" generally refer to the direction within the wellbore towards the surface. Likewise, the terms
10 "down", "downhole", "lower", "below" make reference to the direction within the wellbore away from surface. The terms "inner" and "inward" refer to the direction towards the center of a wellbore, whereas the terms "outer" and "outward" refer to the direction away from the center of a wellbore, for example towards the well bore wall. As those skilled in the art of well bore drilling can appreciate these terms are similarly relevant to deviated and directionally drilled well
15 bores and the tools used therein.

The apparatus is an agitator that can be employed to agitate a wellbore string. The string can be a drill string, as shown, or another string that requires agitator, such as a liner string. As such, while the following description implies a drilling application, the method and apparatus are equally useful for liner placement applications and any other application in which a wellbore
20 string requires agitation.

A typical drilling rig 10 is shown on the surface 12 with a well bore 14 being drilled through subterranean formations 16 towards a target reservoir 18, as shown in Figure 1. Within the wellbore, a string 20 is depicted including a drill bit 22 and a tubular body 24 is shown incorporated with the string. Drilling rig 10 or a downhole motor (not shown) or any other
25 method known in the art may provide the torsional force on the drill bit. The string may include any number and variety of downhole elements 27 such as tools, string subs including measurement-while-drilling tools, drill collars, sensors and the like.

The present invention provides an apparatus and method that allows the operator of a drilling operation to agitate the string in a regular way during pumping of fluid through the string and when there is weight on bit. The apparatus may telescopically compress in response to weight on the string and the apparatus may be used to pump the parts apart until they are stopped or the pressure dissipates and weight urges them back together causing a hammering effect each time the apparatus recompressed after being pumped apart.

Because the hydraulic design is capable of generating significant pressures, the agitator can lift a lot of weight. It can, therefore, be placed close to the bit to have a very direct hammering effect thereon. For example, the agitator can be placed between the bit 22 and the drill collars 27b, such as the non-magnetic drill collars in a directional system. Drill collars, and in particular non-magnetic drill collars, are often called "monels".

For example, with reference to Figures 2A and 2B, the present invention may provide an apparatus. The apparatus may comprise a tubular body 24 for connection within a string 20 including a first mandrel 28 and a second mandrel 30. In this embodiment, the first mandrel is depicted as positioned uphole from the second mandrel.

The tubular body may also include a central bore 26a, 26b defining the longitudinal axis of the body and permitting the flow of fluids, for example drilling mud, through the tubular body from its upper end to its lower end. The body may include the first mandrel and the second mandrel with the central bore extending through both mandrels. The first mandrel may include an outer wall 32 and an inner wall 34.

Central bore 26a, 26b may provide a conduit so that, if the apparatus is connected into the string, the central bore becomes continuous with the bore of the string. This may be of interest for the pumping of drilling fluids from the surface through the string and the body to a drill bit. The second mandrel may include an outer wall 54 and an inner wall 56, the later which defines the central bore 26b through the second mandrel. In one embodiment, first mandrel 28 may include an inner sleeve 42 that forms an extension through which extends portion 26a of the central bore. Inner sleeve 42 extends generally coaxially with, and spaced from, inner wall 34. An annular hollow chamber 36 is formed between sleeve 42 and wall 34. Inner sleeve 42 defines an inner limit of chamber 36, such that chamber 36 is defined as an annular space defined between wall

34 and sleeve 42. The upper end of annular chamber 36 is wall 48 and the lower end of the annular chamber is open.

The second mandrel may be secured, at least partially, within an annular hollow chamber 36 also defined by inner wall 34 of the first mandrel. Second mandrel 30 is telescopically arranged with, and axially moveable, within the first mandrel. The first mandrel and the second mandrel are telescopically arranged and moveable between an axially compressed position Figure 2B and an axially expanded position Figure 2A. In these positions, the mandrels remain connected. A first sealing part 52 and a second sealing part 58 may form part of the apparatus with one sealing part secured to the first mandrel and the other sealing part secured to the second mandrel and both sealing parts are, at least partially, within the fluid flow of the tubular body. The first sealing part and the second sealing part may be positioned to come together when the mandrels are compressed, as by applying weight on the string in which the apparatus is installed. When the sealing parts come together they may form a fluid seal in the central bore to substantially prevent the flow of fluids through the tubular body.

First mandrel 28 may include an inwardly directed ledge 50 on its lower end. Ledge 50 is a return that reduces the inner diameter across chamber 36.

The upper end of the first mandrel may be connectable into the string through a tubular connection 41a, for example a threaded box or pin arrangement or any other tubular connection.

The inner sleeve may include first sealing part 52 on its inner diameter such that first sealing part is positioned in the central bore. For example, the first sealing part may form an annular surface or a seat with a central aperture 53. The first sealing part may extend into central bore to such an extent that fluid flow is substantially not restricted through the central aperture. In an alternate embodiment, first sealing part may extend across central bore and have ports, rather than a central aperture, therethrough to permit the substantially unrestricted fluid flow past first sealing part.

Having described the various embodiments of the elements associated with the first mandrel, the description now turns to the second mandrel, with one embodiment thereof depicted in Figures

2A and 2B. The second mandrel may connect into the string, for example to the drill bit via a tubular connection 41b such as box or pin threading, etc.

The second mandrel may insert into the first mandrel and have a limited range of telescopic movement therein. For example, the second mandrel may be inserted in annular chamber 36 with at least a portion of outer wall 54 axially slidable along wall 34 and inner wall 56 facing the outer surface of inner sleeve 42.

Extending inwardly from the inner wall and into central bore 26b may be second sealing part 58. The second sealing part may include a profile portion 60, which can engage and create a fluidic seal with first sealing part 52 of the first mandrel. In general, the second sealing part may be a variety of relevant shapes such as a dart, a ball point, conical, frustoconical, pyramidal and the like that can plug the center aperture 53 of the first part. For example, the profile portion of second part 58 can seat into and seal against the edges of the center aperture exposed on first sealing part 52.

Regardless of the specific shape, the second sealing part may have adjacent thereto one or more flow ports 62 to permit the flow of drilling fluid to pass and access the central bore of the string downhole of the second mandrel (see flow direction represented by lines X in Figure 2A). The flow ports can be any shape or size to permit such flow of drilling fluid. As will be discussed further below, the flow ports may be positioned so that if the matching profile portion engages the first sealing part drilling fluids cannot flow past the first sealing part to access the central bore there below. Further, the sealing parts are positioned on their respective mandrels such that the sealing parts come together when the mandrels are fully, telescopically compressed.

In an alternative embodiment, where it is not desirable to create a perfect seal in the apparatus second sealing part 58 may also have one or more apertures 63 or the first sealing part may have apertures, to permit the communication of a small flow of fluids across the second sealing part even when the first sealing part and the second sealing part come together. Apertures 63 may permit fluidic communication there across so that drilling fluids may have a restricted flow, arrows x1, past the second sealing part even if matching profile 60 is sealed in the first sealing part. As such, although sealing of the parts is contemplated to form a pressure pulse sufficient to

drive movement and operation of the tool, such a seal may not be a perfect seal so that drilling fluid circulation is not cut off completely.

In one embodiment, the uphole end of second mandrel 30 may include a flange 64 that extends outward therefrom. The flange may, for example, be integral such as a lateral extension of the second mandrel or an additional component secured to the second mandrel such as a safety clip. 5 The flange may extend, at least partially, radially out beyond ledge 50. The engagement of flange 64 with ledge 50 may define the most axially extended position of the limited range of telescopic movement between the first mandrel and second mandrel 30, as shown in Figure 2A.

The apparatus may further include a biasing member 38, if desired, that biases the two mandrels 10 into a partially compressed position because the biasing member has a biasing strength. The biasing member limits the extent to which the parts may be telescopically pulled apart and therefore determines the stroke length. The biasing member may also act as a shock absorber. As will be appreciated, therefore, the biasing member may be omitted if neither stroke length determination or shock absorption are of interest.

15 Biasing member 38 may act between the first mandrel and second mandrel 30 to bias them into a partially compressed position. If the biasing member is disposed in the annular hollow chamber between the flange 64 and the ledge 50, in the most axially extended position, biasing member 38 is fully compressed between the ledge and the flange, as shown in Figure 2A.

Biasing member 38 may be any conventional biasing member such as, for example, a 20 compression spring. As a further example, compression springs may be Belleville springs, coiled compression springs, helical springs, variable pitch conical springs and the like. A coiled compression spring may have a known, constant biasing strength that allows the spring to resist applied compressive forces to a predictable degree. If the compressive forces exceed the biasing strength constant limit, the spring will compress. As will be described further below, the biasing 25 member acts between the two mandrels to bias them into a partially compressed position and in particular, to resist axial movement of the sealing members 53, 60 apart beyond a certain limit. This prevents damaging forces by the two mandrels being forcibly urged apart, once pressure builds up above the sealing members.

The biasing member may be selected, when in a neutral position, to leave some space between the sealing members 53, 60 in order to allow the agitator to be stopped by removing the weight from the string. In particular, by lifting the string off the bottom, the second mandrel may drop by gravity or pump pressure apart such that sealing members do not come together and cannot
5 cause vibration in the string.

The outer surface of inner sleeve 42 may have an annular gland 66 to house an inner sealing member 68. The annular gland may be a rounded groove, a square cut groove, an indentation etc. In the illustrated embodiment of Figures 2A and 2B, annular gland 66 is square cut. The inner sealing member may be an o-shaped sealing ring that protrudes from the annular gland so
10 that the sealing member may be compressed between annular gland 66 and the inner surface of the second mandrel creating therebetween a pressure and fluid seal to prevent fluidic communication between the central bore and the annular hollow chamber. It is to be understood herein that the term "sealing member" will, unless otherwise specified, refer to sealing members composed of materials suitable to create and sustain a seal against the pressures associated with a
15 downhole wellbore drilling environment.

The inner wall of first mandrel 28 may have a lower annular gland 70 to house a lower sealing member 72. The lower annular gland may be a rounded groove, a square cut groove, an indentation etc. In the illustrated embodiment of Figure 2B, the lower annular gland is square cut. The lower sealing member may be an o-shaped sealing ring that protrudes from the lower
20 annular gland so that the lower sealing member may be compressed between the lower annular gland and the outside surface of the second mandrel creating therebetween a pressure and fluid seal to prevent fluidic communication between the wellbore and the annular hollow chamber.

In another embodiment of the present invention, flange 64 may include ports 82 to permit the bi-directional flow of fluids therethrough to decrease the likelihood of a pressure build up on either
25 side of the flange. As one can appreciate, such a build up could create a pressure lock impairing the functionality of the agitation sub.

In one embodiment of the present invention, a dampener 74 may be installed to mitigate damaging contact between the sealing members. The dampener, not shown, may be positioned between wall 48 and the flange.

In another embodiment of the present invention, there may be a transmission arrangement 76 between the first mandrel and the second mandrel to permit the transmission of torsional forces there between. The transmission arrangement may, for example, be a tongue-and-groove arrangement. The transmission arrangement may include the lower sleeve having one or more splines 78 that engage and axially move within one or more receiving grooves 80 on the outer wall of second mandrel 30. The splines and grooves mate so that rotation of one part is transferred to the other part. Of course, the one or more splines may be included on the outer wall of second mandrel and the one or more receiving grooves may be on the inner surface of the lower sleeve.

10 In one embodiment, the mandrels may each be constructed of one piece. In another embodiment, the mandrels may each be constructed of two or more components. For example, as shown in Figure 2A, the first mandrel may be constructed of three primary components, including: an outer sleeve 40 forming walls 32, 34, inner sleeve 42 and a lower sleeve 44 forming ledge 50. The primary components of the first mandrel may define the lateral walls of the annular hollow chamber. For example, lower sleeve 44 may threadedly connect with outer sleeve 40 proximal
15 its lower end. The inner wall of outer sleeve 40, above the connection point with lower sleeve 44, may define an inner wall 34 open to the annular hollow chamber. The inner sleeve may threadedly connect to outer sleeve 40, below the tubular connection and above the end wall. The outer wall of the inner sleeve may extend below the end wall to define an inner wall and of the
20 annular hollow chamber.

In operation, the apparatus can be placed in a string and positioned downhole. The apparatus may be connected in-line with a wellbore string so that the position of second mandrel in the first mandrel is dependent upon weight on the string; applying torsional and axial forces on the string to position the first mandrel and the second mandrel in the fully compressed position; pump
25 fluids through the string to develop a fluid pressure overcoming the weight on bit holding the first mandrel and the second mandrel in a sealing position and driving the first mandrel and the second mandrel apart; allowing the pressure to dissipate when the first mandrel moves out of sealing position with the second mandrel such that the first mandrel returns back to a sealing position against the second mandrel; and continuing to pump fluids through the string to create

an agitation effect of the first mandrel and the second mandrel being pumped apart and then returned to a sealing position

For example, when the string is urged down against the bottom or against frictional forces below the apparatus, herein called weight on bit, the apparatus is driven to axially compress, which
5 causes the sealing members to come together (Figure 2B). When fluid is pumped through the string, it is stopped by the seal formed by the seated sealing parts and parts 52, 58 can only be forced apart when sufficient pressure builds up in bore 26a. The force must be sufficient to lift mandrel 28 off mandrel 30.

When the pressure builds, the parts will be forced apart, causing mandrels 28, 30 to move into
10 their axially extended position. Then, when the pressure dissipates by passage through bore 26b, the weight of the string causes the sealing parts to come back to together (Figure 2B) until pressure forces them apart again (Figure 2A). Thus, the effect is a regular hammering and agitation in the string as the parts cycle: pressure forces the parts apart and then they come back together.

15 In the sealing position, the profile of the second sealing part may seat in and create a fluidic seal with the profile of the first sealing part, as shown in Figure 2B, and thereby prevent the flow of fluids there through (except for any small flow through port 63). The fluidic seal may be created by the profile of the second sealing part blocking central aperture 53 of the first sealing part, which prevents the flow of fluids through the central bore of the tubular body.

20 The fluidic seal may prevent any fluid communication across the first sealing part so that, for example, drilling fluids being pumped from surface down the central bore of the string will no longer communicate below the fluidic seal provided by parts 52, 58. The effect of creating such a fluidic seal, while drilling fluid continues to be pumped from surface, is agitation and hammering in the string.

25 If the apparatus is positioned between the drill bit and the drill collar, driving the first mandrel and the second mandrel apart includes lifting a drill collar upwardly (i.e. toward surface) away from the drill bit. Thus, the agitation and hammering can be applied very close and perhaps directly at the drill bit.

The first and second mandrel may be arranged so that torsional forces are transmitted between the two mandrels. For example, the lower sleeve may have one or more splines that engage and axially move within one or more receiving grooves on the outer wall of second mandrel that
5 mate with the one or more splines, or vice versa, the one or more splines may be included on the outer wall of second mandrel and the one or more receiving grooves may be on the inner surface of the lower sleeve.

The previous description of the disclosed embodiments is provided to enable any person skilled in the art to make or use the present invention. Various modifications to those embodiments will
10 be readily apparent to those skilled in the art, and the generic principles defined herein may be applied to other embodiments without departing from the spirit or scope of the invention. Thus, the present invention is not intended to be limited to the embodiments shown herein, but is to be accorded the full scope consistent with the claims, wherein reference to an element in the singular, such as by use of the article "a" or "an" is not intended to mean "one and only one"
15 unless specifically so stated, but rather "one or more". All structural and functional equivalents to the elements of the various embodiments described throughout the disclosure that are known or later come to be known to those of ordinary skill in the art are intended to be encompassed by the elements of the claims. Moreover, nothing disclosed herein is intended to be dedicated to the public regardless of whether such disclosure is explicitly recited in the claims. No claim element
20 is to be construed under the provisions of 35 USC 112, sixth paragraph, unless the element is expressly recited using the phrase "means for" or "step for".

Claims:

1. An apparatus comprising: a tubular body for connection within a string including a first mandrel and a second mandrel, and a central bore defining a longitudinal axis of the tubular body and creating a flow path permitting a flow of fluids between the two mandrels and through the tubular body, the second mandrel secured, at least partially, within an annular bore of the first mandrel so that the second mandrel is telescopically arranged with and axially moveable within the first mandrel between a telescopically extended position and a compressed position; and a first sealing part and a second sealing part, one of the first and the second sealing part being secured to the first mandrel and the other sealing part being secured to the second mandrel, both sealing parts being within the fluid flow path of the tubular body, the first sealing part and the second sealing part being positioned to come together when the first mandrel and the second mandrel are in the compressed position to form a seal in the fluid path, the seal substantially preventing the flow of fluids through the tubular body.
2. The apparatus of claim 1 further comprising a biasing member acting between the first mandrel and the second mandrel and biasing the first mandrel and the second mandrel toward the compressed position.
3. The apparatus of claim 1 further comprising a transmission arrangement between the first mandrel and the second mandrel to transmit torsional forces therebetween.
4. The apparatus of claim 1 further comprising a dampener to act between the first mandrel and the second mandrel in the compressed position to mitigate damaging contact between the first sealing part and the second sealing part.
5. The apparatus of claim 1 wherein the first sealing part has an aperture therethrough forming a portion of the fluid flow path and the second sealing part includes a profile portion that seats in and plugs the center aperture when the first sealing part and the second sealing part come together to form a seal.
6. A drill string comprising: a string of tubulars; a drill bit connected at a distal end of the string of tubulars; a drill collar; and a hydraulically driven agitator positioned between the drill bit and the drill collar.

7. The drill string of claim 6 wherein the hydraulically driven agitator includes: a tubular body including a first mandrel connected at an upper end directly or indirectly to the drill collar and a second mandrel connected at a lower end directly or indirectly to the drill bit, and a central bore defining a longitudinal axis of the tubular body and creating a flow path permitting a flow
5 of fluids between the two mandrels and through the tubular body, the second mandrel secured, at least partially, within an annular bore of the first mandrel so that the second mandrel is telescopically arranged with and axially moveable within the first mandrel between a telescopically extended position and a compressed position; and a first sealing part and a second sealing part, one of the first and the second sealing part being secured to the first mandrel and the
10 other sealing part being secured to the second mandrel, both sealing parts being within the fluid flow path of the tubular body, the first sealing part and the second sealing part being positioned to come together when the first mandrel and the second mandrel are in the compressed position to form a seal in the fluid path, the seal substantially preventing the flow of fluids through the tubular body.

15 8. The drill string of claim 7 wherein the hydraulically driven agitator further comprises a biasing member acting between the first mandrel and the second mandrel and biasing the first mandrel and the second mandrel toward the compressed position.

9. The drill string of claim 7 wherein the hydraulically driven agitator further comprises a transmission arrangement between the first mandrel and the second mandrel to transmit torsional
20 forces therebetween.

10. The drill string of claim 7 wherein the hydraulically driven agitator further comprises a dampener to act between the first mandrel and the second mandrel in the compressed position to mitigate damaging contact between the first sealing part and the second sealing part.

11. The drill string of claim 7 wherein the first sealing part has an aperture therethrough
25 forming a portion of the fluid flow path and the second sealing part includes a profile portion that seats in and plugs the center aperture when the first sealing part and the second sealing part come together to form a seal.

12. A method for creating an agitation effect in a wellstring, the method comprising:
connecting an apparatus according to claim 1 in-line with a wellbore string to position the second
mandrel and the first mandrel in the compressed position when there is weight on bit in the
wellbore string; applying weight on bit to position the first mandrel and the second mandrel in
5 the fully compressed position; pumping fluids through the wellbore string to develop a fluid
pressure overcoming the weight on bit holding the first mandrel and the second mandrel in
compressed position and driving the first mandrel and the second mandrel apart; allowing the
pressure to dissipate such that the first mandrel and the second mandrel return back to the
compressed position; and continuing to pump fluids through the wellbore string to create an
10 agitation effect as the first mandrel and the second mandrel continue to be pumped apart and then
returned to the compressed position.

13. The method of claim 12 further comprising applying torsional forces through the
wellbore string and transmitting the torsional forces through the apparatus.

14. The method of claim 12 wherein driving the first mandrel and the second mandrel apart
15 includes lifting a drill collar upwardly away from a drill bit.

