

No Model.)

2 Sheets—Sheet 1.

A. M. DREISBACH. RAILROAD SWITCH.

No. 559,268.

Patented Apr. 28, 1896.

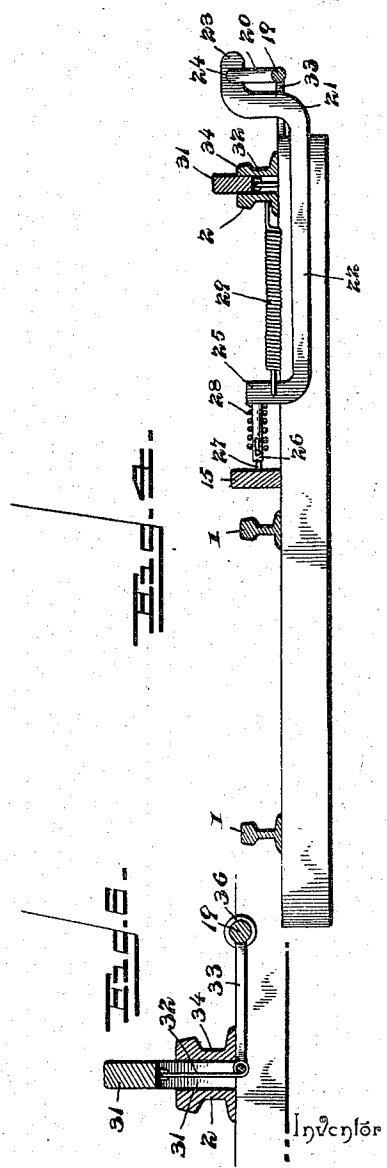
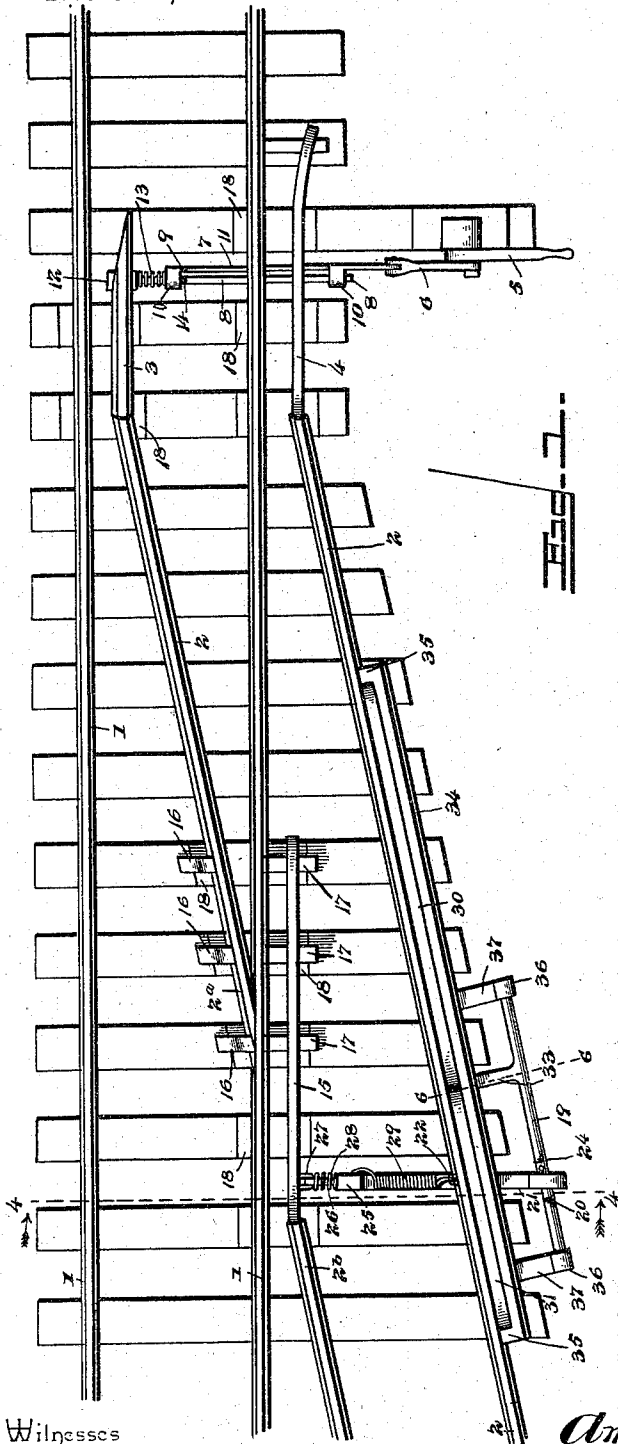

Witnesses

E. H. Stewart

C. J. [Signature]

By *W. H. [Signature]* Attorneys.

Amos M. Dreisbach

Chas. [Signature]

(No Model.)

2 Sheets—Sheet 2.

A. M. DREISBACH. RAILROAD SWITCH.

No. 559,268.

Patented Apr. 28, 1896.

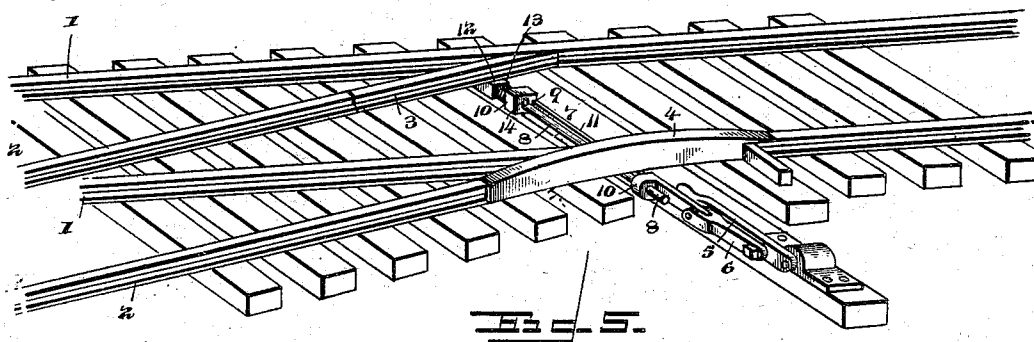
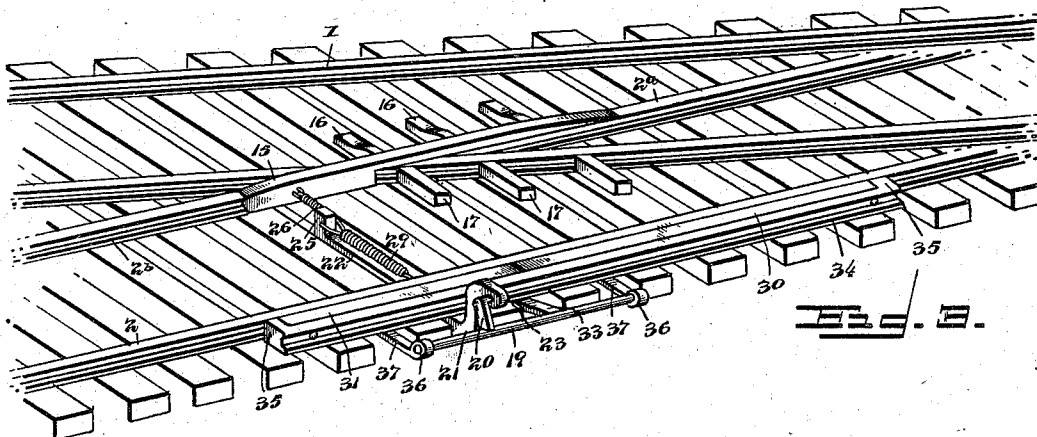
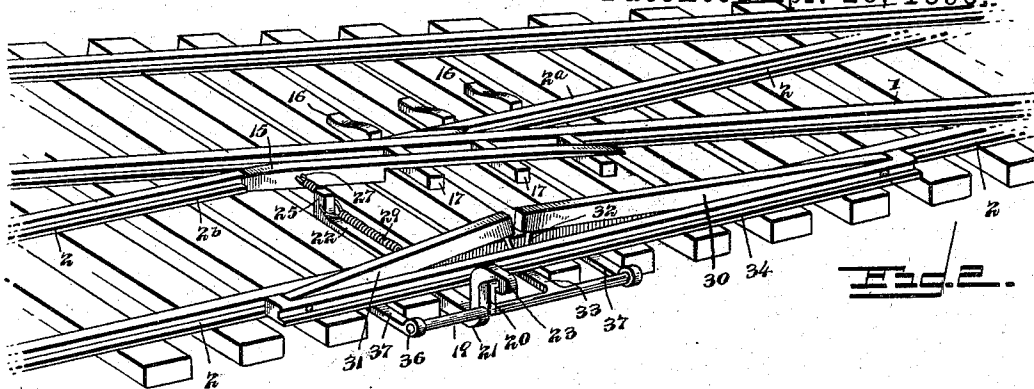

Inventor

Amos M. Dreisbach

Witnesses

E. M. Stewart
C. E. Hoff

By *his* Attorneys.

C. A. Snow & Co.

UNITED STATES PATENT OFFICE.

AMOS M. DREISBACH, OF CABEL, PENNSYLVANIA, ASSIGNOR TO LEWIS CORELLE, OF SAME PLACE, AND LAFAYETTE FROMETTER, GEORGE FROMETTER, AND JAMES KASEMAN, OF SHAMOKIN, PENNSYLVANIA.

RAILROAD-SWITCH.

SPECIFICATION forming part of Letters Patent No. 559,268, dated April 28, 1896.

Application filed April 17, 1895. Serial No. 546,071. (No model.)

To all whom it may concern:

Be it known that I, AMOS M. DREISBACH, a citizen of the United States, residing at Cabel, in the county of Northumberland and State of Pennsylvania, have invented a new and useful Railroad-Switch, of which the following is a specification.

My invention relates to railroad-switch mechanism, and has for its object to provide a simple, efficient, and comparatively inexpensive arrangement of parts whereby a frog for the intersection of the inner siding and main track rails to support the inner wheels of a car in passing from the main to the siding track, or vice versa, may be avoided, and whereby the parts of the mechanism are set for the siding-track to direct the wheels of the car to and from the siding-track by the weight of the car, to provide simple means for cushioning the parts to prevent jarring and straining during operation, and to provide improved switch-rails and means for operating the same whereby the efficient operation of the parts is insured.

Further objects and advantages of this invention will appear in the following description, and the novel features thereof will be particularly pointed out in the appended claims.

In the drawings, Figure 1 is a plan view of a switch mechanism constructed in accordance with my invention, the parts being shown in their normal positions which they occupy when the switch mechanism is set for the main track. Fig. 2 is a detail view in perspective of the frog-rail and operating mechanism, the parts being shown in the positions indicated in Fig. 1. Fig. 3 is a similar view showing the frog-rail arranged in alinement with the siding-track, as when the tread rails or bars are depressed by the wheels of a car. Fig. 4 is a transverse section on the line 4 4 of Fig. 1. Fig. 5 is a detail view in perspective of the main switch-rails and operating parts set for the siding-track. Fig. 6 is a detail section on the line 6 6 of Fig. 1.

Similar numerals of reference indicate corresponding parts in all the figures of the drawings.

1 designates the main-track rails and 2 the

siding-track rails, the inner siding and main track rails being arranged to intersect, as in the ordinary construction. The pivotal switch-rails 3 and 4 are arranged to aline at their extremities with the main-track rails when the switch is set for the siding-track, the rail 3 being adapted to bear at its extremity against one side of the main-track rail, while the switch-rail 4 is of greater height than the track-rails and is cut away to fit over the tread of the same, as clearly shown in Fig. 5. The tread of this switch-rail 4 is inclined at its extremities to agree with the plane of the treads of the main rails, and is raised at its center to a height above the tread of the main rails equal to or greater than the flange of a wheel, whereby the wheel which is supported by said switch-rail 4 is carried over the main-track rail. This avoids the necessity of cutting or breaking the continuity of the rail and causing the wheels of the car to jump the interval between the parts thereof.

The means for adjusting the switch-rails to the main or siding track positions consist of a switch arm or lever 5, connected by means of a link 6 to the switch-bar 7, and this switch-bar comprises a rod 8, secured at points near its extremities to the switch-rails 3 and 4, and a slide 9, mounted upon the rod and having a limited sliding movement thereon. Said slide comprises the terminal eyes 10, connected by a bar 11, and interposed between the outer eye 10 and the shoulder 12 on the rod 8 is a coiled spring 13. The movement of the slide 9 is limited by a stop 14 on the rod 8 when the lever or handle is swung in a direction to withdraw the extremities of the switch-rails from engagement with the main-track rails, and when the lever or handle is moved in the opposite direction, to cause the switch-rails to connect with the main-track rails, the movement of the slide is communicated to the rod 8 through the coiled spring, and hence the switch-rails are held with a firm spring-pressure against the track-rails to prevent accidental displacement.

A frog-rail 15 is employed to connect the portion 2^a of the inner siding-track rail or the portion thereof which is between the main-

track rails with the portion 2^b thereof which is beyond the inner main-track rail, said frog-rail being of greater height than the track-rails in order to carry the flanges of the wheels
 5 over the main-track rail in entering the siding. This frog-rail is cut away to extend over and rest upon the treads of the main and siding track rails when the parts are in the positions shown in Fig. 3, and the extremities of
 10 the tread of the frog-rail are beveled to allow the wheels of a car to pass upon and from the same with facility. The stationary stops 16 are arranged upon the ties contiguous to the extremity of the portion 2^a of the siding-track
 15 rail, said stops being elevated slightly above the tread of this portion of the rail, whereby the movement of the frog-rail 15 beyond its proper position in alinement with the siding-track rail is prevented. The free end of the
 20 frog-rail is supported, when out of alinement with the siding-track rail, by means of guide-blocks 17, which are flush at their upper sides with the tread of the main-track rail, and said guide-blocks and stops are secured to the ties
 25 by means of iron plates 18.

The means for imparting motion to the frog-rail to arrange it in its various positions comprise a rock-shaft 19, having a crank-arm 20, which is connected by a bar 21 with the frog-rail. The bar 21 is provided with a depressed
 30 central portion 22 to pass under the contiguous siding-track rail, a raised outer extremity having a bearing 23, which is fitted upon a trunnion 24 at the extremity of the crank-arm
 35 20, and a raised inner extremity 25, having a slotted extension 26 connected by means of a loop 27 with the rail 15. The slotted connection between the extension and the loop provides for independent longitudinal movement
 40 of said parts, and an expansion-spring 28, which is interposed between the elevated inner end of the connecting-bar and the end of the loop, has the effect of forcing the frog-rail against the stops 16 with a firm pressure when
 45 the connecting-bar is in the position indicated in Fig. 3. A retraction-spring 29 is employed to return the parts to the positions shown in Figs. 1 and 2, in which the frog-rail is out of alinement with the siding-track rails and the
 50 main track is open.

The means for imparting motion to the rock-shaft to throw the frog-rail to alinement with the siding-track rails comprise tread-rails 30 and 31, the former being preferably longer
 55 than the latter and extending beyond the free end of the frog-rail 15, whereby a car in entering the siding runs upon the tread-rail 30 and depresses the latter before the opposite wheel comes into a position to contact with
 60 the extremity of the frog-rail. The tread-rails 30 and 31 are pivoted at their remote ends, and at their free inner or contiguous extremities are connected by means of links 32 to the free end of a crank-arm 33. Hence the depression
 65 of one of the tread-rails turns the rock-shaft sufficiently to throw the frog-rail into alinement with the inner siding-track rail. The

tread-rails are arranged parallel with and contiguous to the outer side of the outer siding-track rail and between the same and an auxiliary rail 34, said auxiliary rail having offset
 70 terminal portions 35, which bear against the outer side of the outer siding-track rail and thus form a cavity of a width approximately equal to that of the tread-rails. The tread-rails are equal in height to the track-rails, and hence when depressed are flush at their upper
 75 edges with the treads of the track-rails, as indicated in Fig. 3. The rock-shaft is mounted at its extremities in bearings 36 at the outer ends of brackets 37, secured to the under surfaces of the outer siding-track rail and the auxiliary rail.

From the above description it will be seen that as a car approaches the intersection of the main and siding track rails one of the tread-rails which normally stands at an inclination to the plane of the treads of the track-rails is depressed, and motion is thereby communicated to the frog-rail to throw the free
 85 end of the latter over the inner siding-track rail, whereby the wheels upon that side of the car are carried over the main-track rail without contact therewith, and the combined lengths of the tread-rails is such that the
 90 wheels of one truck of a car do not leave one of the tread-rails until the wheels on the other truck of said car pass upon the outer end of the other tread-rail. In this way the frog-rail is held permanently in its operative position during the passage to or from the siding-track of an entire train. Furthermore, the cushion-springs which are used between the connecting-bar and the frog-rail and between the slide and the shoulder of the rod forming one member of the switch-bar prevent the jarring of the parts in moving them to their adjusted positions and at the same time serve to hold the parts of the switch mechanism in their adjusted positions against
 100 displacement by vibration or otherwise.

The advantage in pivotally mounting the remote ends of the tread-rails at fixed points upon the rail and arranging their free inner ends at an interval such that they will be approximately in contact when the tread-rails are depressed resides in the fact that the operation of the tread-rails consists solely of a downward swinging movement thereof instead of a combined swinging and sliding movement, as in tread-rails heretofore designed for a similar purpose. In a device of this class it is the object to attain the desired result with the minimum amount of movement and friction, and by the arrangement above described the only friction is that caused at the pivotal points by the swinging movement of the rails, the weight of said rails serving to assist the depression thereof, and at the same time when depressed their free ends are approximately in contact, whereby a wheel traverses the interval without jar.

Various changes in the form, proportion, and the minor details of construction may be

resorted to without departing from the spirit or sacrificing any of the advantages of this invention.

Having described my invention, what I claim is—

1. The combination with main and siding track rails, the former being continuous, of a pivotal frog-rail adapted to aline with the inner siding-track rail, a rock-shaft, connections between the rock-shaft and said frog-rail, tread-rails arranged contiguous to, and parallel with, the outer siding-track rail and having their remote ends pivoted at fixed points to said rail and their free inner ends arranged at an interval whereby they are approximately in contact when the upper edges of the tread-rails are in the plane of the tread of the track-rail, and independent connections between the inner free ends of the tread-rails and said rock-shaft, substantially as specified.

2. The combination with main and siding track rails, the former being continuous, of a pivotal frog-rail having its tread above the plane of the treads of the track-rails and adapted to swing thereover to occupy a position in alinement with the siding-track rail, stops to limit the movement of the frog-rail, a rock-shaft, a connecting-rod between the rock-shaft and the frog-rail and having a

sliding connection with the latter, a cushion-spring interposed between the connecting-rod and the frog-rail, and a retracting spring to remove the frog-rail from alinement with the siding-track rail, substantially as specified.

3. The combination with main and siding track rails, the former being continuous, and a frog-rail adapted to swing over the same to aline with the inner siding-track rail, of a rock-shaft, a connecting-bar between the rock-shaft and the frog-rail, a cushion-spring between the connecting-bar and the frog-rail, stops to limit the movement of the frog-rail, a return-spring for the connecting-bar, tread-rails arranged contiguous to the outer siding-track rail and having free inner and pivotal outer ends, an auxiliary rail secured to the outer siding-track rail and spaced between its extremities therefrom to receive the tread-rails, and connections between the free ends of the tread-rails and the rock-shaft, substantially as specified.

In testimony that I claim the foregoing as my own I have hereto affixed my signature in the presence of two witnesses.

AMOS M. DREISBACH.

Witnesses:

GEORGE C. WEISER,
WILLIAM V. WEAVER.