

June 16, 1959

M. SKUMAWITZ

2,890,454

DEVICE FOR DRIVING NAILS, BOLTS, AND THE LIKE

Filed Sept. 24, 1956

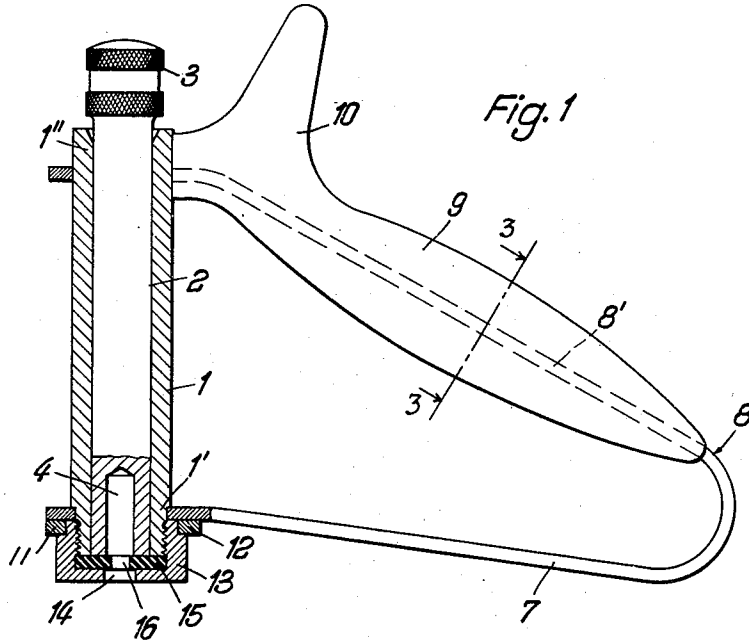

Fig. 1

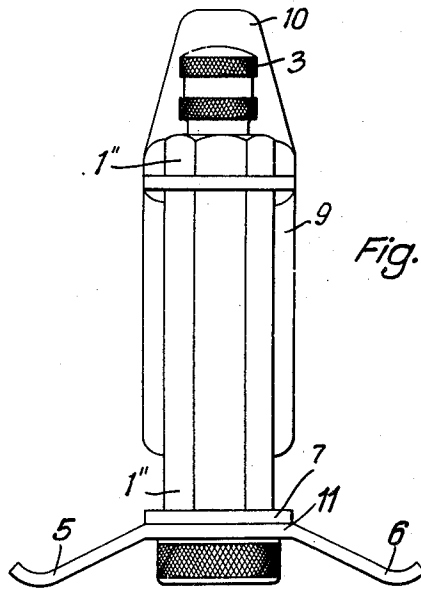

Fig. 2

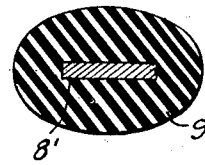

Fig. 3

1

2,890,454

**DEVICE FOR DRIVING NAILS, BOLTS,
AND THE LIKE**

Max Skumawitz, Lintorf Bezirk Dusseldorf, Germany, as-
signor to Tornado Ramset G.m.b.H. & Co.

Application September 24, 1956, Serial No. 611,422

Claims priority, application Germany October 4, 1955

8 Claims. (Cl. 1—47)

This invention relates to a device for driving nails, bolts and the like, having a sleeve provided at its front end with an opening for the reception and guidance of a nail and a hammer or striker, which is movable in the sleeve, and by which the nail or the like is driven.

The known nail driving devices of the above-mentioned kind have a relatively small end surface which is placed on the surface to be nailed which often results in the bolts, nails or the like being driven in obliquely. Further, in the known devices the sleeve which guides the striker also acts as a handle so that, if the device is operated without sufficient care, the operator may be injured. A further disadvantage of the known device is that it must be provided with separate means for guiding and holding the nail at the end of the sleeve facing the place where the nail is to be driven in, such means being in the form of clamps or the like which considerably increase the cost of the device.

The object of the present invention is to provide a nail driving device which does not possess the above-mentioned disadvantage and is of simple construction and which, when placed on the surface to be nailed, is held in an upright position and consequently assures that the nail, bolt or the like is driven in at right angles to the surface. This result is obtained, in accordance with the invention, by providing the nail driving device at its end face, which is placed on the surface to be nailed, with a number of extended feet which support it over a wide area, one of the feet being also formed as a handle. The handle advantageously consists of a resilient loop which is of substantially V-shape and is fixed to the ends of the sleeve. The upper part of the loop is provided with a rubber handle which, at the end adjacent the sleeve and the head of the striker, has a projection which acts as a hand guard. The resilient loop, together with the other two feet, which are formed by the downwardly bent ends of a resilient plate fixed to the sleeve form a three-point support which tends to hold the device in its normal or vertical position.

According to a further feature of the invention, a rubber centering and holding disc for the nail or the like is provided at the lower end of the sleeve, the disc having a suitable bore for the insertion of the nail. Owing to the resilience of the centering and holding disc, the bore of which closely surrounds the nail, the nail to be driven is securely held and guided when being driven.

A nail driving device constructed in accordance with the invention is illustrated, by way of example, in the accompanying drawing, in which:

Fig. 1 is a side elevational view partly in section of the nail driving device;

Fig. 2 is a front elevational view of the device shown in Fig. 1; and

Fig. 3 is a sectional view taken on line 3—3 of Fig. 1.

Referring to the drawing, the nail driving device consists essentially of a sleeve 1 and a striker 2 which is movably guided in the sleeve and provided with a head 3.

2

The striker 2 is provided at its lower end with a recess 4 for the reception of a nail or nail-head. In order to enable the device to be easily manipulated, that end of the sleeve which has to be placed on the surface into which the nail is to be driven is provided with extended feet 5, 6 and 7 which afford support over a wide area. One of the feet consists of a substantially V-shaped loop 8 which is fixed to the ends 1', 1'' of the sleeve. The upper part 8' of the loop 8 is provided with a rubber handle 9 having at its end adjacent the head 3 a projection 10 which acts as a hand guard. The remaining two feet 5 and 6 are each formed by a resilient plate 11, the ends of which are slightly bent downwardly. The plate 11 is formed in the middle with a bore 12 and together with the lower arm 7 of the loop 8, which has a similar bore, is fixed to the sleeve 1 by means of a screw-cap 13 which engages in the bore 12. The screw-cap 13 is provided with an opening 14 for the passage of the nail and also acts as a support for a rubber centering and holding disc 15 for the nail. The disc 15 has a hole 16 which is slightly smaller than the hole 14 in the cap 13.

The new driving device, owing to the provision of the extended feet 5, 6 and 7, is automatically held in its normal or vertical driving position, and owing to the construction and arrangement of the handle 9, 10 the operator is protected against injury. In addition, the rubber disc 15 at the lower end of the sleeve 1 affords an extremely simple support and guide for the nail which, together with the remaining features, enables the construction of the device to be extremely simple.

It will be noted that, owing to the arrangement of the feet 5, 6 and 7 which is T-shaped in plan, the device can also be tilted into an inclined position simply by turning it about the straight line passing through the points of contact of the feet 5, 6 with the surface to be nailed.

I claim:

1. A device for driving nails, bolts and the like, comprising a tubular sleeve having an opening at one end for receiving and guiding the article to be driven, a striker movable in said sleeve, and feet projecting from said one end of said sleeve by which it may be supported over a wide area, one of said feet including an upward extension being formed as a handle.

2. A device as claimed in claim 1, said one foot being in the form of a substantially V-shaped loop the ends of which are attached to the sleeve adjacent the ends thereof, and the upper part of said loop being provided with a rubber handle.

3. A device for driving nails, bolts and the like, comprising a tubular sleeve having an opening at one end for receiving and guiding the article to be driven, a striker movable in said sleeve and feet extending from said one end of said sleeve by which it may be supported over a wide area, one of said feet being in the form of a resilient loop the ends of which are attached to said sleeve, thereby forming a hand grip.

4. The device according to claim 3, wherein the resilient loop serving as hand grip is provided at its upper part with a handle having a projection at the end adjacent the sleeve, said handle serving as a guard for the hand.

5. The device according to claim 4, wherein a resilient plate forms two of said feet, said plate being bent slightly downwardly and having a central bore, and a screw cap for attaching said plate to said sleeve together with the lower end of said loop, thereby forming the lower front end of the device.

6. A device for driving nails, bolts and the like, comprising a tubular sleeve having an opening at one end for receiving and guiding an article to be driven, a striker movable in said sleeve, and feet projecting from said

3

one end of said sleeve, one of said feet including an upward extension being formed as a handle and the remaining two feet being formed by a plate having downwardly bent ends and means for attaching said plate to said sleeve.

7. A device as claimed in claim 6, said means comprising a cap threaded on said sleeve, said plate being secured to said sleeve by said cap.

8. A device for driving nails and the like as claimed in claim 7, comprising a rubber disc with a bore for the reception of a nail or the like disposed in tight engage-

5

10

4

ment between said cap and said sleeve for supporting and guiding nails.

References Cited in the file of this patent

UNITED STATES PATENTS

91,392	Wheeler	June 15, 1869
968,688	Redmond	Aug. 30, 1910
2,418,118	Hamilton	Apr. 1, 1947

FOREIGN PATENTS

669,496	France	Aug. 5, 1929
---------	--------	--------------