

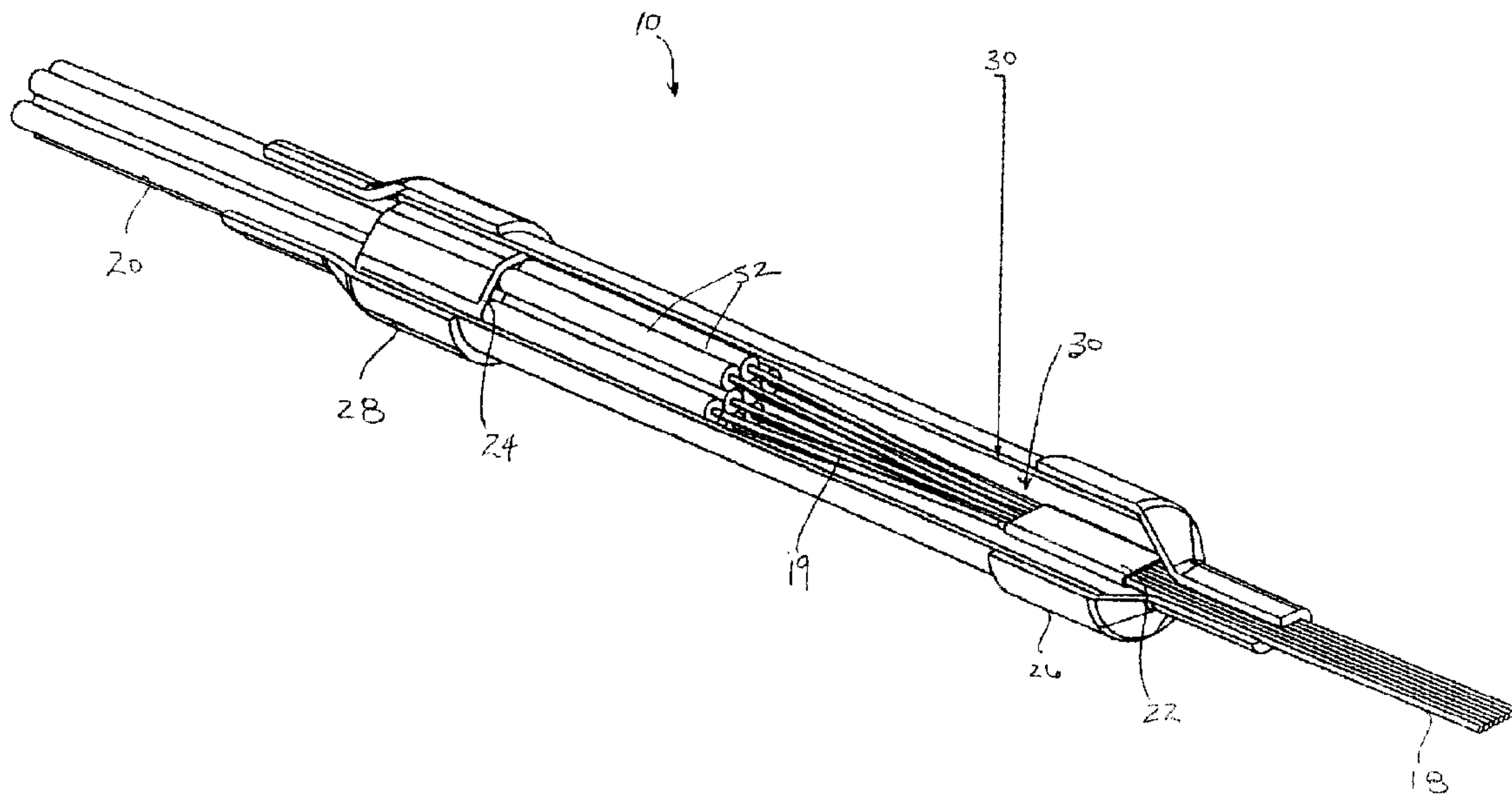

(22) Date de dépôt/Filing Date: 2003/04/04
(41) Mise à la disp. pub./Open to Public Insp.: 2003/11/07
(30) Priorité/Priority: 2002/05/07 (10/140,642) US

(51) Cl.Int.⁷/Int.Cl.⁷ G02B 6/44, G02B 6/24
(71) Demandeur/Applicant:
CORNING CABLE SYSTEMS LLC, US
(72) Inventeurs/Inventors:
WAGNER, KARL M., US;
JAMES, KENNETH T., US
(74) Agent: GOWLING LAFLEUR HENDERSON LLP

(54) Titre : RAMIFICATION DE FIBRES OPTIQUES SOUPLES A HAUTE PERFORMANCE
(54) Title: HIGH PERFORMANCE, FLEXIBLE OPTICAL FIBER FURCATION



(57) **Abrégé/Abstract:**

This invention provides an apparatus and method for a high performance, flexible optical fiber furcation assembly that controls microbending of the optical fibers throughout the life of the furcation assembly. The furcation assembly includes a flexible furcation body having a passageway with a first end and an opposed second end, the first end for receiving a fiber optic cable and the second end for routing a furcated leg, and holding material for flexibly securing and supporting the fiber optic cable and the furcated leg substantially within the single passageway. The method of applying a furcation assembly to a fiber optic cable includes the steps of stripping a cable sheath from the fiber optic cable to expose an optical fiber, fanning out the optical fiber, inserting a first end of the fiber optic cable into a flexible furcation body, sliding the flexible furcation body over a predetermined portion of the optical cable and the fanned-out optical fiber, and introducing a holding means into the furcation body positioned over the predetermined portion, such that the holding means flexibly secures and supports the fiber optic cable and the optical fibers within the passageway. The apparatus and method of this invention apply to a variety of optical cable types.

PATENT

Attorney Docket No. HE0173

HIGH PERFORMANCE, FLEXIBLE OPTICAL FIBER FURCATION ASSEMBLY

ABSTRACT OF THE DISCLOSURE

This invention provides an apparatus and method for a high performance, flexible optical fiber furcation assembly that controls microbending of the optical fibers throughout the life of the furcation assembly. The furcation assembly includes a flexible furcation body having a passageway with a first end and an opposed second end, the first end for receiving a fiber optic cable and the second end for routing a furcated leg, and holding material for flexibly securing and supporting the fiber optic cable and the furcated leg substantially within the single passageway. The method of applying a furcation assembly to a fiber optic cable includes the steps of stripping a cable sheath from the fiber optic cable to expose an optical fiber, fanning out the optical fiber, inserting a first end of the fiber optic cable into a flexible furcation body, sliding the flexible furcation body over a predetermined portion of the optical cable and the fanned-out optical fiber, and introducing a holding means into the furcation body positioned over the predetermined portion, such that the holding means flexibly secures and supports the fiber optic cable and the optical fibers within the passageway. The apparatus and method of this invention apply to a variety of optical cable types.

PATENT

Attorney Docket No. HE0173

TITLE OF THE INVENTION

HIGH PERFORMANCE, FLEXIBLE OPTICAL FIBER FURCATION

FIELD OF THE INVENTION

5 This invention relates generally to the field of fiber optic cable assemblies. More particularly, this invention relates to a high performance, flexible optical fiber furcation assembly.

BACKGROUND OF THE INVENTION

10 Fiber optic communications has experienced explosive growth. In just a few years, the transmission of communication signals for voice, video, data, and the like has soared, and more growth is planned as fiber optic communication technology improves and networks expand to provide greater access.

Inherent with any fiber optic network is the need to connect individual optical fibers
15 from optical cables to other optical fibers by using one of a multitude of fiber optic assemblies. The connection of these optical fibers must be executed with great care and precision in order to minimize losses in the transmitted communication signal. These connections take a great deal of time because each optical fiber in a cable is usually manually routed and/or furcated and then individually connected to other optical fibers.

20 When furcating optic cables, a furcation assembly is used to reduce microbending of the optical fibers, which is a bending of the optical fiber that causes signal attenuation. The furcation assemblies known in the art suffer from the shortcomings of being rigid, difficult to manufacture, difficult to install, and/or sensitive to environmental factors that damage the cable sheath and/or the optical fibers. This damage typically results in increased signal
25 attenuation.

PATENT

Attorney Docket No. HE0173

A need therefore exists for an apparatus and method that provides an improved furcation assembly that enhances the performance of and minimizes the damage to optical fibers in a furcation assembly.

5 **SUMMARY OF THE INVENTION**

Accordingly, the present invention is directed to an apparatus and method to protect furcated optical fibers against mechanical and/or environmental factors. The present invention is also directed to a high performance, flexible furcation assembly that minimizes bending in the optical fibers throughout the life of the furcation assembly. Additional features and advantages of the invention will be set forth in the description which follows, 10 and in part will be apparent from the description, or may be learned by practice of the invention. The objectives and other advantages of the invention will be realized and attained by the assembly and method particularly pointed out in the written description and claims hereof as well as the appended drawings.

15 To achieve these and other advantages and in accordance with the purpose of the invention, as embodied and broadly described, the invention is directed to a furcation assembly that includes a flexible furcation body having a first end and an opposed second end with a single passageway extending therebetween, the first end for receiving a portion of a fiber optic cable and the second end for routing a portion of at least one optical fiber of the fiber optic cable out of the furcation assembly, and holding means for flexibly securing and 20 for flexibly supporting the portion of the fiber optic cable and the portion of at least one optical fiber substantially within the single passageway, such that the holding means minimizes bending of the portion of the fiber optic cable and the portion of at least one optical fiber.

25 According to another aspect, the invention is directed to a furcation assembly that includes a flexible furcation body having a single passageway with a first end and an

PATENT

Attorney Docket No. HE0173

opposed second end, the first end for receiving a portion of a fiber optic cable and the second end for routing a portion of at least one optical fiber of the fiber optic cable out of the furcation assembly, and holding means for flexibly securing and for flexibly supporting the portion of the fiber optic cable and the portion of at least one optical fiber within the single
5 passageway.

According to yet another aspect, the invention is directed to a method of applying a furcation assembly to a fiber optic cable that includes inserting a portion of a first end of the fiber optic cable into a flexible furcation body, the flexible furcation body having a first end and an opposed second end with a single passageway therebetween, stripping a cable sheath
10 from the portion of the first end of the fiber optic cable to expose at least one optical fiber, fanning out a portion of the at least one optical fiber, sliding the flexible furcation body over a predetermined portion of the fanned-out portion of the at least one optical fiber and over a predetermined portion of the first end of the fiber optic cable, and introducing a holding means into the furcation body, wherein the holding means flexibly secure and flexibly
15 support the portion of the first end of the fiber optic cable and the fanned-out portion of at least one optical fiber substantially within the single passageway.

According to another aspect, the invention is directed to a method of routing a fiber optic cable in a furcation assembly that includes inserting a portion of a first end of the fiber optic cable into a flexible furcation body, the flexible furcation body having a first end and
20 an opposed second end with a single passageway therebetween, stripping a cable sheath from the portion of the first end of the fiber optic cable to expose at least one optical fiber, sliding the flexible furcation body over a predetermined portion of the at least one optical fiber and over a predetermined portion of the first end of the fiber optic cable, and introducing a holding means into the flexible furcation body, wherein the holding means flexibly secure
25 and flexibly support the portion of the first end of the fiber optic cable and the at least one optical fiber substantially within the single passageway.

PATENT

Attorney Docket No. HE0173

It is to be understood that the both the foregoing general description and the following detailed description are exemplary and explanatory and are intended to provide further explanation of the invention as claimed.

The accompanying drawings are included to provide a further understanding of the invention and are incorporated in and constitute a part of this specification, illustrate several embodiments of the invention and together with the description serve to explain the principles of the invention.

BRIEF DESCRIPTION OF THE DRAWINGS

FIG. 1 is a perspective view of fiber optic furcation assembly according to an embodiment of this invention;

FIG. 2 is a partial cross-sectional view of the assembly of FIG. 1;

FIG. 3 is an exploded perspective view of the assembly of FIG. 1; and

FIG. 4 is a flowchart illustrating operations performed according to a method.

DETAILED DESCRIPTION OF THE INVENTION

This invention now will be described more fully hereinafter with reference to the accompanying drawings, in which several embodiments of the invention are shown. This invention may, however, be embodied in many different forms and should not be construed as limited to the embodiments set forth herein; rather, these embodiments are provided so that this disclosure will be thorough and complete, and will fully convey the scope of the invention to those skilled in the art. Like numbers refer to like elements throughout.

Referring now to FIGS. 1-3, a furcation assembly **10** in accordance with an embodiment of this invention is shown. The furcation assembly **10** includes a furcation body **12** having a single passageway **30** with a first end **14** and an opposed second end **16**, the first

PATENT

Attorney Docket No. HE0173

end **14** for receiving a fiber optic cable **18**, illustrated as an optical fiber ribbon, and the second end **16** for routing at least one leg **20** of the fiber optic cable out of the furcation assembly **10**. While an optical fiber ribbon is shown, any optical cable in any configuration could be used. As shown best in FIGS. 2 and 3, the optical fibers **19** from the optical cable **18** are separated and, as described in more detail below, covered with fan-out buffer tubes **52** before exiting the furcation assembly. However, it should be noted that the optical fibers, depending upon the cable design being furcated, may not need to have fan-out buffer tubes. If such buffer tubes are to be used, the buffer tubes **52** may be fabricated out of nylon and be dimensioned so that the optical fiber easily passes through the tube. Preferably, the buffer tube has an outer diameter of about 900 microns and an inner diameter sufficient to allow the optical fiber, which has an outer diameter of about 250 microns, to be inserted therein.

The furcation assembly **10** also preferably includes a first fiber optic holding component **22** securable about the fiber optic cable **18**, and a second fiber optic holding component **24** securable around a portion of at least one leg of the fiber optic cable to support and secure the optical fibers during use and assembly, as discussed in more detail below. However, the holding components **22,24** may be excluded if desired as they assist in the manufacturing process, but are not absolutely required. The furcation assembly **10** also preferably includes a first furcation end component **26** securable about the first end **14** of the single passageway and a second furcation end component **28** securable about the second end **16** of the furcation body **12**. While the first and second components (the fiber optic holding components and the furcation end components) are illustrated as being aligned with one another, they do not have to be and, in fact, may not be aligned depending on the size and length of furcation body **12**. Similarly, the holding components **22,24** and the end components **26,28** are preferably made of a glue-lined heat-shrink material, but any other material that would hold the optical fibers in place and seal the ends of the furcation body, respectively, would be acceptable, e.g., tape, bands, rubber boots, O-rings, etc. The end and holding components do not have to be of the same materials, but could be of any

PATENT

Attorney Docket No. HE0173

combination of acceptable materials. For example, the holding components could be rubber O-rings and the end components be rubber boots. Similarly, one holding component could be tape while the other end component is a glue-lined heat shrink material.

The single passageway **30** is filled with holding and adhesive material **50**, such as
5 Dow Corning's® RTV sealant, filling the voids around the optical cable and the portion of the legs that are within the furcation body to thereby flexibly secure and flexibly support the fiber optic cable and optical fibers throughout the passageway. The furcation end components **26,28** seal the holding adhesive material within the single passageway and provide further environmental protection for the optical cable and optical fibers within the
10 furcation assembly. The furcation body **12** is typically a flexible, lengthwise-extending, mesh tube having a hollow interior. Preferably, the furcation body is Varflex® HP tubing. The mesh tube, because it is breathable, allows the RTV sealant to cure around the cable, optical fibers, and legs. Other materials that cure and remain relatively flexible may also be used. However, the materials must cure without using heat, although UV-curable materials
15 may also be used. If a UV-curable material is used, then the furcation body must be transparent to UV sources.

In accordance another embodiment and as illustrated in Fig. 4, a method of applying a furcation assembly **10** to a fiber optic cable **18** is provided. The method includes the step
20 **101** of determining the location of the furcation on the fiber optic cable. At steps **103**, one end of the cable is prepared for the furcation. At step **103** the cable can be inserted into a holding component **22**, preferably a glue-lined heat-shrink component, at the position where the optical fibers are to be separated from one another and the holding component secured to the cable. The holding component **22** keeps the optical fibers from separating from one another further along the cable than desired. Then at step **105**, one end of the cable is
25 prepared for the furcation. This step may also include the striping of the ribbon matrix from the ribbon cable or other cable structure from the optical fibers, depending on the type of cable, to expose and fan-out at least one optical fiber of about 250 microns in diameter.

PATENT

Attorney Docket No. HE0173

Obviously, all of the optical fibers in the cable can be furcated in any given furcation assembly. At step **107**, a fan-out buffer tube **52** is preferably disposed over each optical fiber that is to be furcated. The fan-out buffer tubes may all be bundled together before the optical fibers are placed therein with a second fiber optic holding member **24**. While this manner is preferable, the buffer tubes could be placed on the fibers before they are bundled together or the buffer tubes could be left loose. At step **109**, the second furcation end member **28** is positioned over one end of the optical cable and, at step **111**, a flexible furcation body **12** is positioned over cable so that the cable and fibers pass through the single passageway **30** of the furcation body **12**. If the end members are other than the heat-shrink elements or rubber-boots, for example, then the furcation body may be positioned over the cable before the end member. One end of the furcation body is disposed relative to the second furcation end member to allow the end of the furcation body to be sealingly engaged by the second furcation end component. The flexible furcation body **12** and furcation end component **28** are positioned over a predetermined portion of the fiber optic cable and the furcated legs **20**. Preferably, there is a small gap between the first fiber optic holding member and the end of the fan-out buffer tubes so that the optical fibers are exposed. At step **113**, the holding material is introduced into the furcation body and allowed to dry, cure, set, or harden, depending on the holding material. The holding material preferably secures and supports the fiber optic cable, the exposed optical fibers, and the legs in a flexible manner within the single passageway. At step **115**, the first furcation end is disposed on the cable and securingly attached to the other end of the furcation body. It should be noted that either the first or the second furcation end member can be used first in the method and still be within the scope of the invention.

Several common disadvantages in prior art furcation assemblies is that they are not flexible, have poor performance, and do not provide a mechanism to flexibly secure and support the fiber optic cable and optical fibers throughout the passageway to minimize the formation of bends in the optical fiber(s). The furcation assembly of this invention is

PATENT

Attorney Docket No. HE0173

extremely flexible and is able to withstand a wide range of temperature cycling (e.g., -40° C to 85° C) while minimizes microbending, tensile loads up to three pound increments for up to two minutes, and many other rigors.

Many modifications and other embodiments of the invention will come to mind to
5 one skilled in the art to which this invention pertains having the benefit of the teachings
presented in the foregoing descriptions and the associated drawings. Therefore, it is to be
understood that the invention is not to be limited to the specific embodiments disclosed and
that modifications and other embodiments are intended to be included within the scope of the
appended claims. Although specific terms are employed herein, they are used in a generic
10 and descriptive sense only and not for purposes of limitation.

PATENT

Attorney Docket No. HE0173

WHAT IS CLAIMED IS:

1. A furcation assembly comprising:

5 a flexible furcation body having a first end and an opposed second end with a single passageway extending therebetween, the first end for receiving a portion of a fiber optic cable and the second end for routing at least one furcated leg of the fiber optic cable out of the furcation assembly; and

10 holding means for flexibly holding and supporting the portion of the fiber optic cable and the at least one furcated leg substantially within the single passageway, such that the holding means minimizes bending of the portion of the fiber optic cable and the at least one furcated leg.

2. The furcation assembly of claim 1, further comprising:

5 at least one buffer tube for the at least one furcated leg, the at least one buffer tube having a first routing end and a second end, wherein the first end is located substantially within the flexible furcation body and wherein the second end is located substantially outside the flexible furcation body.

3. The furcation assembly of claim 2, wherein the buffer tube has a diameter of about 900 microns.

4. The furcation assembly of claim 2, wherein the at least one furcated leg has a diameter of about 250 microns.

PATENT

Attorney Docket No. HE0173

5. The furcation assembly of claim 1, wherein the flexible furcation body comprises a lengthwise extending breathable tube.
6. The furcation assembly of claim 1, wherein the holding means comprises an adhesive for holding the portion of the fiber optic cable and the portion of at least one optical fiber substantially within the single passageway.
7. The furcation assembly of claim 6, wherein the adhesive comprises silicone.
8. The furcation assembly of claim 1, further comprising:
 - sealing means for substantially sealing the holding means within the single passageway.
9. The furcation assembly of claim 8, wherein the sealing means comprises:
 - a first furcation end component sealingly engaging the first end of the flexible furcation body; and
 - a second furcation end component sealingly engaging the second end of the flexible furcation body.
10. A furcation assembly comprising:
 - a flexible furcation body having a single passageway with a first end and an opposed second end, the first end for receiving a portion of a fiber optic cable and the second end for routing a portion of at least one furcated leg of the fiber optic cable out of the furcation assembly; and

PATENT

Attorney Docket No. HE0173

holding means for flexibly holding and supporting the portion of the fiber optic cable and the at least one furcated leg within the single passageway.

11. A method of applying a furcation assembly to a fiber optic cable, comprising the steps of:
- preparing the fiber optic cable to be furcated;
 - sliding a flexible furcation body, the flexible furcation body having a first end and an
 - 5 opposed second end with a single passageway therebetween; and
 - introducing a holding means into the furcation body, wherein the holding means flexibly holds and supports a portion of the fiber optic cable substantially within the single passageway.
12. The method of claim 11, wherein the step of preparing the fiber optic cable includes the step of stripping a portion of the fiber optic cable to expose at least one optical fiber.
13. The method of claim 11, wherein the step of preparing the fiber optic cable includes fanning out at least one optical fiber from the fiber optic cable.
14. The method of claim 11, wherein the step of preparing the fiber optic cable includes placing fan-out buffer tubes on the exposed at least one optical fiber.
15. The method of claim 14, wherein introducing a sealing means on at least one predetermined portion of the flexible furcation assembly comprises:
- overmolding a thermoplastic resin on at least one predetermined end of the flexible furcation assembly.
16. The method of claim 11, further comprising:

PATENT

Attorney Docket No. HE0173

securingly attaching an end component at one end of the flexible furcation assembly.

16. A method of applying a furcation assembly to a fiber optic cable, comprising the steps of:

placing a first fiber optic holding component at a first desired location on the fiber optic cable and securing the first fiber optic shrink component into place;

stripping a cable sheath from an end of the fiber optic cable to expose at least one optical fiber;

fanning out a portion of at least one optical fiber;

placing a second fiber optic holding component at a second desired location on the fanned-out portion of at least one optical fiber and securing the second fiber optic shrink component into place;

inserting the end of the fiber optic cable into a flexible furcation body;

sliding the flexible furcation body over a predetermined portion of the fiber optic cable and the fanned-out portion of at least one optical fiber;

placing a second furcation holding component over the flexible furcation tube and the second fiber optic holding component and securing the second furcation holding into place;

injecting an adhesive into the flexible furcation tube at a first end of the flexible furcation tube near the first fiber optic holding component; and

placing a first furcation holding component over the flexible furcation tube and the first fiber optic holding component and securing the first furcation holding into place.

17. The method of claim 16, wherein fanning out the portion of at least one optical fiber further comprises:

routing the portion of at least one optical fiber through at least one buffer tube.

PATENT

Attorney Docket No. HE0173

18. The furcation assembly of claim 17, wherein the buffer tube has a diameter of 900 microns and the optical fiber has a diameter of 250 microns.
19. A method of routing a fiber optic cable in a furcation assembly, comprising the steps of:
- placing a first fiber optic holding component at a first desired location on the fiber optic cable and securing the first fiber optic shrink component into place;
 - stripping a cable sheath from an end of the fiber optic cable to expose at least one optical fiber;
 - fanning out a portion of at least one optical fiber;
 - placing a second fiber optic holding component at a second desired location on the fanned-out portion of at least one optical fiber and securing the second fiber optic shrink component into place;
 - inserting the end of the fiber optic cable into a flexible furcation body;
 - sliding the flexible furcation body over a predetermined portion of the fiber optic cable and the fanned-out portion of at least one optical fiber;
 - placing a first furcation holding component over the flexible furcation tube and the first fiber optic holding component and securing the first furcation holding into place;
 - injecting an adhesive into the flexible furcation tube at a second end of the flexible furcation tube near the second fiber optic holding component; and
 - placing a second furcation holding component over the flexible furcation tube and the second fiber optic holding component and securing the second furcation holding into place.
20. A method of routing a fiber optic cable in a furcation assembly, comprising the steps of:

PATENT

Attorney Docket No. HE0173

inserting a portion of a first end of the fiber optic cable into a flexible furcation body, the flexible furcation body having a first end and an opposed second end with a single passageway therebetween;

stripping a cable sheath from the portion of the first end of the fiber optic cable to expose at least one optical fiber;

sliding the flexible furcation body over a predetermined portion of the at least one optical fiber and over a predetermined portion of the first end of the fiber optic cable; and

introducing a holding means into the flexible furcation body, wherein the holding means flexibly secure and flexibly support the portion of the first end of the fiber optic cable and the at least one optical fiber substantially within the single passageway.

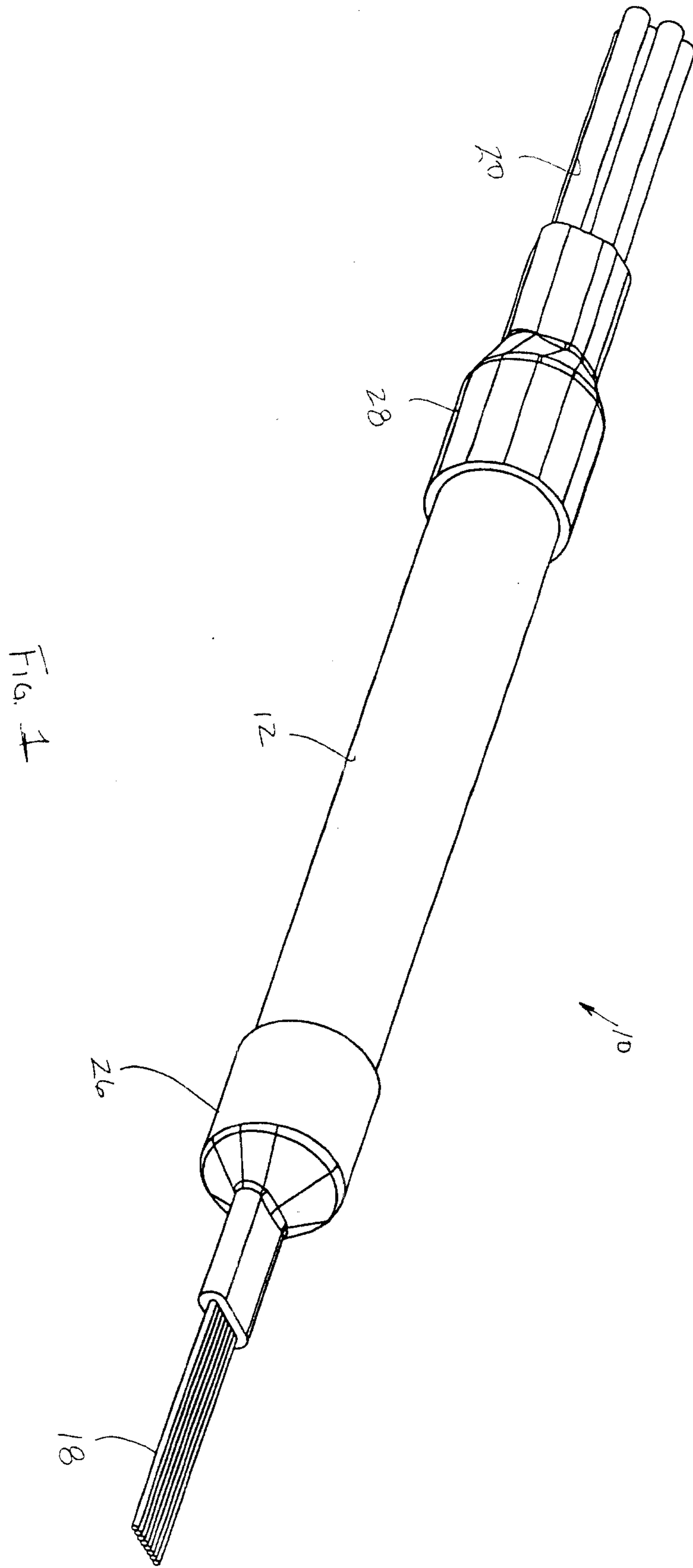

FIG. 1

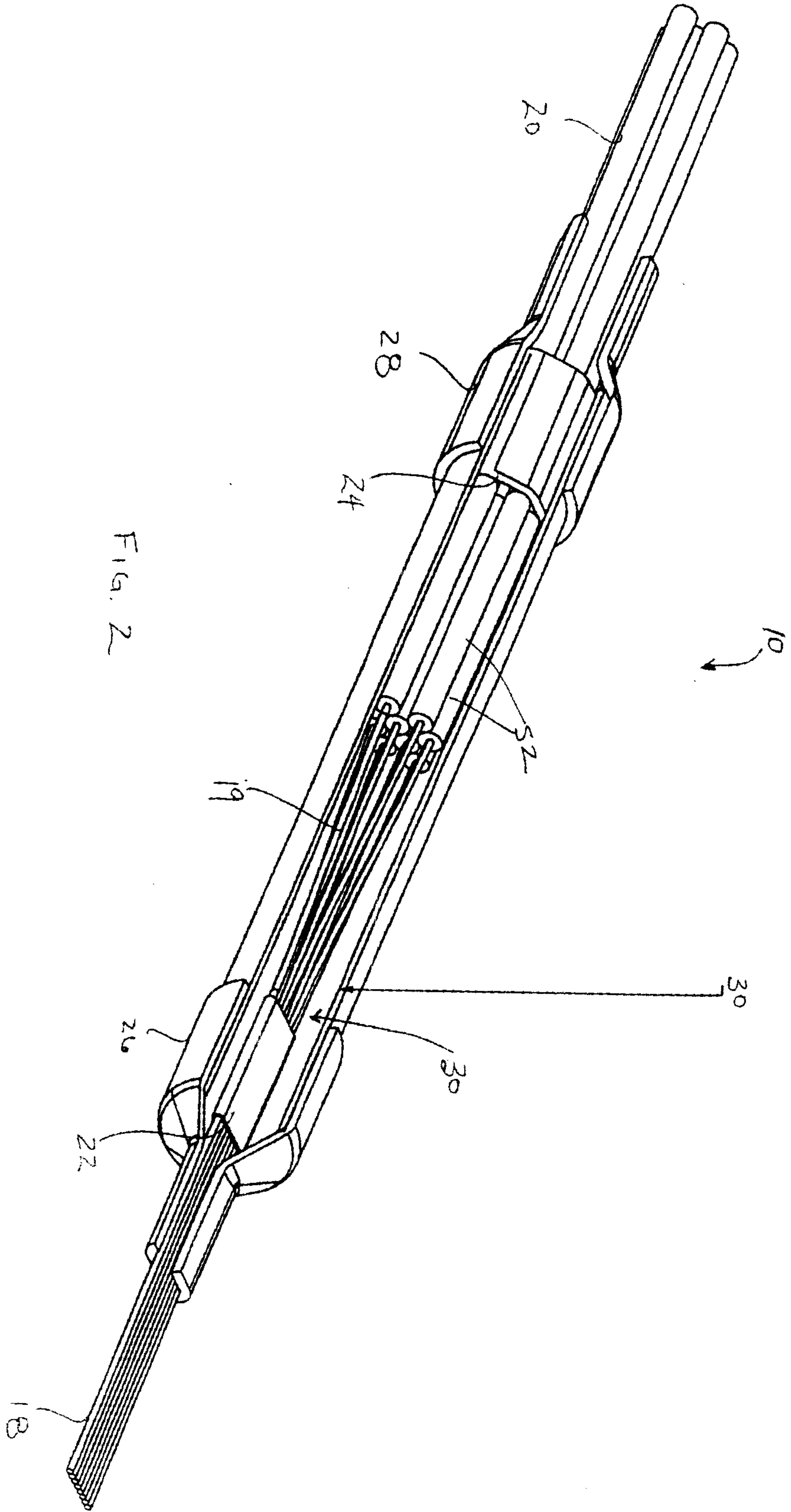
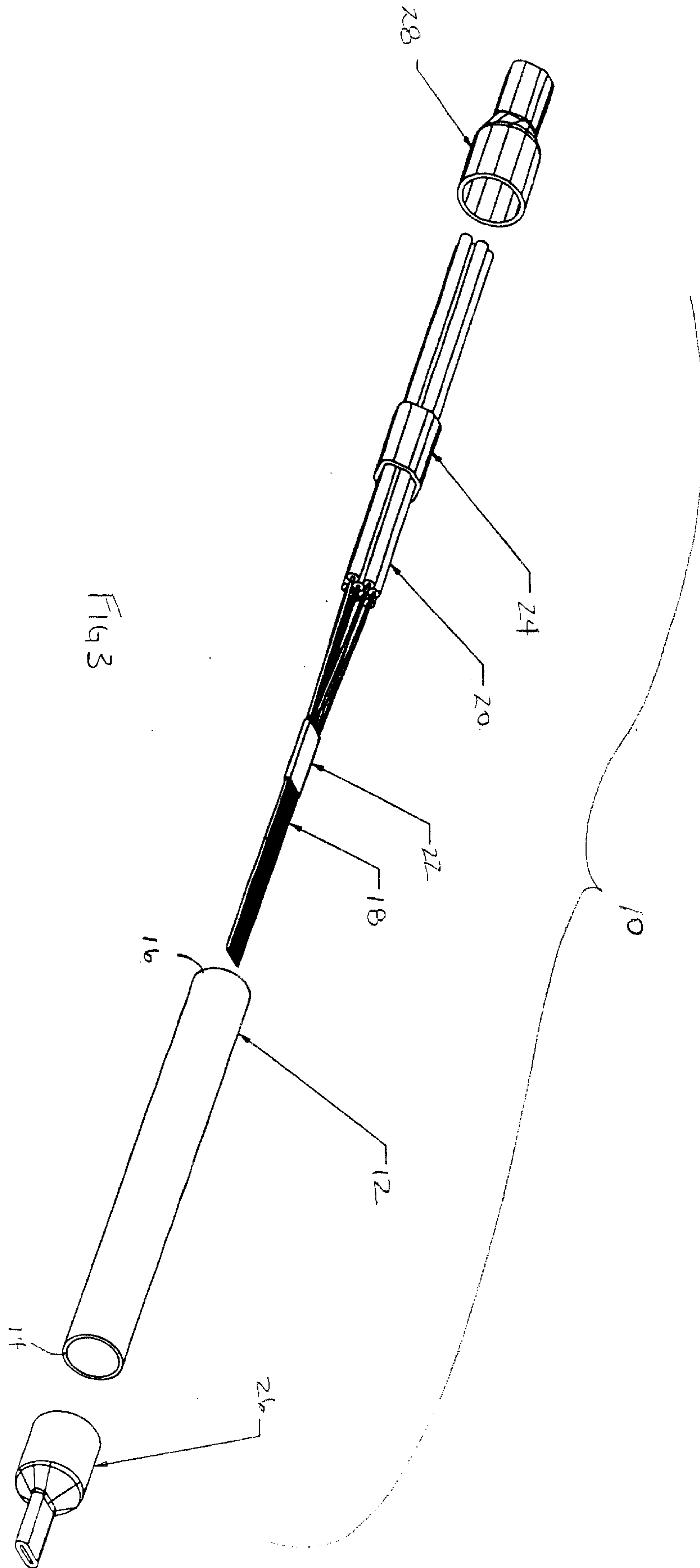

FIG. 2



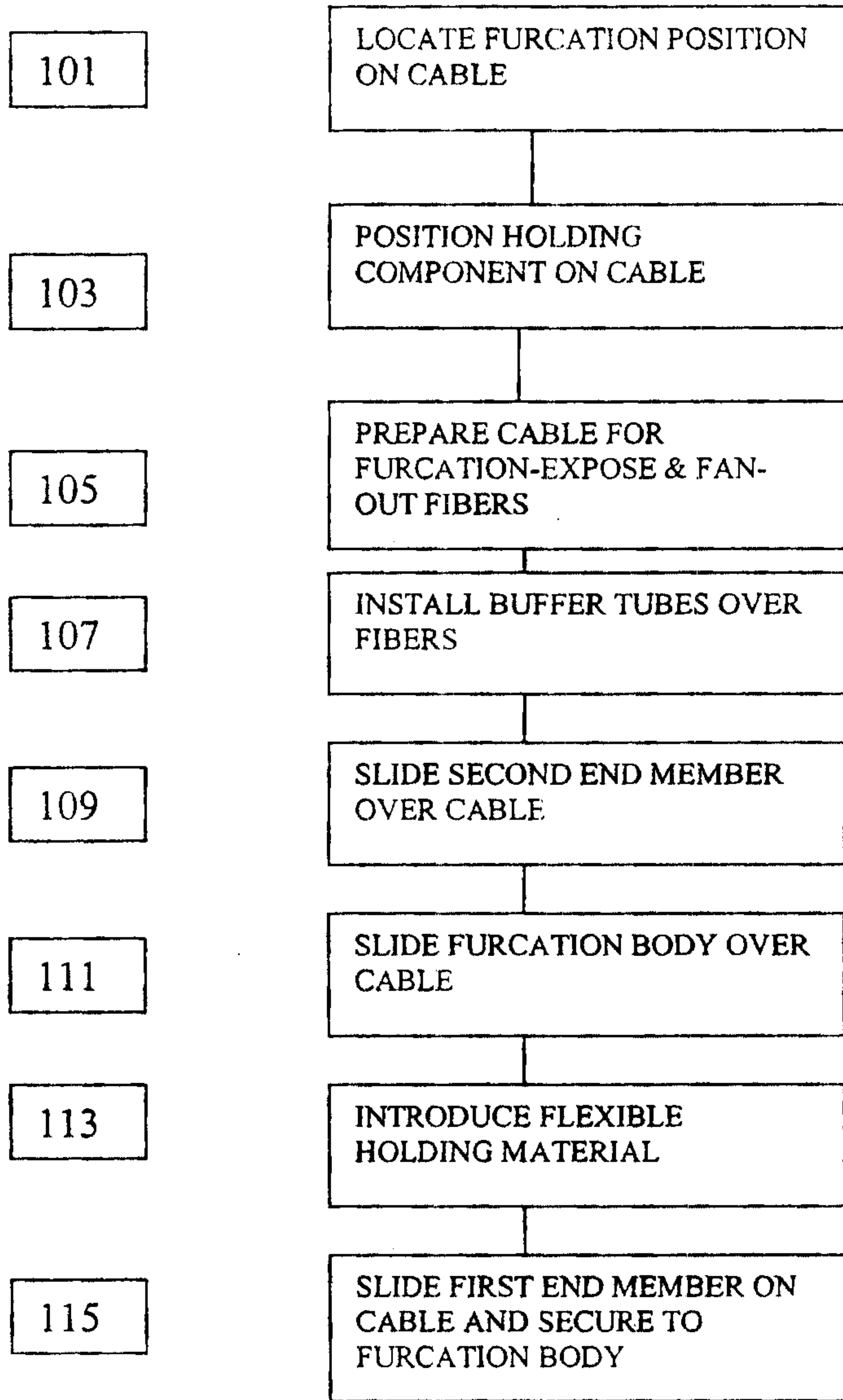

FIG. 4

