



- (51) International Patent Classification:
G06Q 10/08 (2012.01) G06Q 50/28 (2012.01)
- (21) International Application Number:
PCT/US2014/014011
- (22) International Filing Date:
31 January 2014 (31.01.2014)
- (25) Filing Language: English
- (26) Publication Language: English
- (30) Priority Data:
13154795.2 11 February 2013 (11.02.2013) EP
- (71) Applicant: 3M INNOVATIVE PROPERTIES COMPANY [US/US]; 3M Center, Post Office Box 33427, Saint Paul, Minnesota 55133-3427 (US).
- (72) Inventors: KIRCHMEYER, Domenica; Carl-Schurz-Strasse 1, 41453 Neuss (DE). BIALLUCH, Robert; Carl-Schurz-Strasse 1, 41453 Neuss (DE).
- (74) Agents: NOWAK, Sandra K., et al.; 3M Center Office of Intellectual Property Counsel, Post Office Box 33427, Saint Paul, Minnesota 55133-3427 (US).

- (81) Designated States (unless otherwise indicated, for every kind of national protection available): AE, AG, AL, AM, AO, AT, AU, AZ, BA, BB, BG, BH, BN, BR, BW, BY, BZ, CA, CH, CL, CN, CO, CR, CU, CZ, DE, DK, DM, DO, DZ, EC, EE, EG, ES, FI, GB, GD, GE, GH, GM, GT, HN, HR, HU, ID, IL, IN, IR, IS, JP, KE, KG, KN, KP, KR, KZ, LA, LC, LK, LR, LS, LT, LU, LY, MA, MD, ME, MG, MK, MN, MW, MX, MY, MZ, NA, NG, NI, NO, NZ, OM, PA, PE, PG, PH, PL, PT, QA, RO, RS, RU, RW, SA, SC, SD, SE, SG, SK, SL, SM, ST, SV, SY, TH, TJ, TM, TN, TR, TT, TZ, UA, UG, US, UZ, VC, VN, ZA, ZM, ZW.
- (84) Designated States (unless otherwise indicated, for every kind of regional protection available): ARIPO (BW, GH, GM, KE, LR, LS, MW, MZ, NA, RW, SD, SL, SZ, TZ, UG, ZM, ZW), Eurasian (AM, AZ, BY, KG, KZ, RU, TJ, TM), European (AL, AT, BE, BG, CH, CY, CZ, DE, DK, EE, ES, FI, FR, GB, GR, HR, HU, IE, IS, IT, LT, LU, LV, MC, MK, MT, NL, NO, PL, PT, RO, RS, SE, SI, SK, SM, TR), OAPI (BF, BJ, CF, CG, CI, CM, GA, GN, GQ, GW, KM, ML, MR, NE, SN, TD, TG).

Published:
— with international search report (Art. 21(3))

(54) Title: METHOD AND APPARATUS FOR IDENTIFYING AN OBJECT

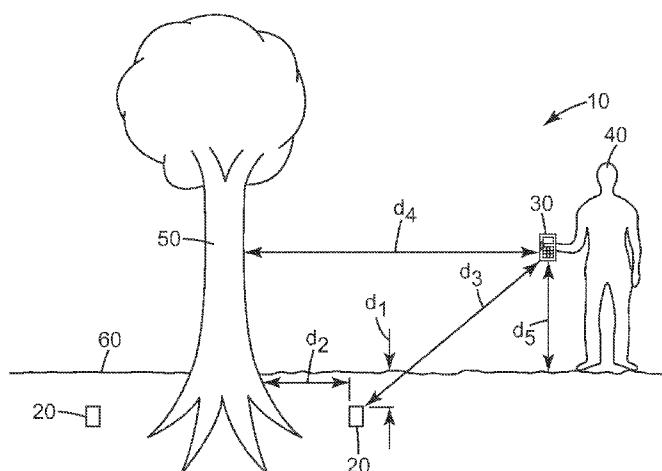

Fig. 1a

(57) Abstract: Methods and apparatus are disclosed for identifying an above-ground, ground-anchored object, the ground-anchored object being tagged with at least one below-ground electronic marker unit. The method involves providing a remote reader, using the remote reader to interrogate a below-ground volume, to obtain electronic marker data from the electronic marker units, and using the electronic marker data to determine the identity and/or location of the ground-anchored object. Ground anchored objects may include trees, road intersections, or road furniture such as benches, a traffic barriers or signs. The preferred electronic marker unit uses a radio frequency passive transponder. Also disclosed are methods for tagging a ground-anchored object involving burying an electronic marker unit in the ground at a predetermined depth and at a predetermined marker distance from the ground-anchored object.

WO 2014/123767 A1

METHOD AND APPARATUS FOR IDENTIFYING AN OBJECT

The present invention relates to methods of identifying above ground, ground anchored objects, to apparatus for tagging and identifying above ground, ground anchored objects and to methods of tagging above ground, ground anchored objects.

Organisations responsible for road maintenance and security require the inventory of objects on the roads to be recorded. Such objects may include road signs, pavement marking, road furniture, trees, or other ground-anchored objects. Software based systems are known. These systems typically use video technology to record the road condition and ground-anchored objects. The objects can later be located or identified using GPS, the inventory database and signs or markers attached to the object. When inspection of the object or objects becomes necessary, workers check the sign or markers and refer to the database and GPS systems.

Other components and systems for use in recording objects are known.

WO-A-2007/141424 concerns a road system device comprising a road system component wherein is provided a receiver port, a transponder, and a link element.

US-A-2009/0128336 relates to a method and system for monitoring forest products.

In a first aspect of the present invention, there is provided a method of identifying an above-ground, ground-anchored object, the ground-anchored object being tagged with at least one below-ground electronic marker unit, the method comprising providing a remote reader, using the remote reader to interrogate a below-ground volume, thereby obtaining electronic marker data from one or more electronic marker units in the below-ground volume and, using the electronic marker data to determine the identity and/or location of the ground-anchored object.

This invention is advantageous because it addresses issues with known methods where identification of objects is required by close approach and, usually, direct visual examination of the sign or marker. This may be difficult especially since signs or markers fixed to the object (even in protective casings) may be susceptible to vandalism or weathering over the years in which the identification method is intended to operate. In the case of trees, growth of the tree (e.g. of the bark) may also damage the sign or marker.

This invention addresses this problem because it provides an identification method which does not require direct, especially, visual approach to the object, but is a remote system. A further advantage is that the electronic marker unit (because it is buried below ground) is less susceptible to damage, deliberate or inadvertent removal, especially since the electronic marker unit can be buried at some depth in the ground yet reading of the information is still possible. Furthermore, fixing of the electronic marker

unit to the ground anchored object is not necessary which is advantageous because the object will not thereby be damaged by bolts, nails or other fixing devices

5 Generally this method is applicable to any ground-anchored object where at least a portion of the object is above ground when tagged with the electronic marker units (and above ground means where at least a portion of the ground anchored object is above ground).

The method is also useful where due to circumstance (e.g. vandalism, deliberate or inadvertent removal) part of the above ground portion of the ground anchored object has been removed subsequent to tagging with the electronic marker unit. The method may be used both to locate (e.g. where above ground parts have been removed or plant growth obscures) and/or identify the ground anchored object.

10 Usually, the ground-anchored object is selected from a tree, a road intersection (i.e. a part of the road system where identification would be useful), pavement marking (especially permanent pavement marking) or an object of road furniture. The road furniture may generally be selected from a bench, a traffic barrier, a bollard, a post box, a streetlamp, a traffic light, or a traffic sign. Road intersections and pavement markings are ground anchored and have above ground portions.

15 In the usual case where the ground anchored object is visible, the method may further comprise a step, before using the remote reader to interrogate a below-ground volume, of locating an above-ground, ground-anchored object.

20 Generally, using the remote reader to interrogate the below-ground volume comprises using the remote reader at a predetermined object distance from the ground-anchored object to interrogate a below-ground volume. The object distance would generally be determined (and may have been recorded e.g. in an inventory database and/or the software of the remote reader) taking account of the nature of the object and proximity of other objects (that may or may not be tagged). Usually, the predetermined object distance will be in the range of 0.5 m to 5 m, preferably 1 m to 3 m.

25 Generally, using the remote reader to interrogate the below-ground volume comprises using the remote reader at a predetermined bearing from the ground-anchored object to interrogate a below-ground volume. The bearing may be a compass bearing from the object or determined with reference to landmarks (e.g. other ground anchored objects of the same or different kind) or other electronic marker units which have been used to tag the ground anchored object (if more than one is used). The bearing would usually be recorded in an inventory database and/or the software of the reader.

30 Usually, the remote reader will be a hand-held remote reader. In other circumstances however, the remote reader may be a vehicle mounted remote reader.

Generally, the at least one electronic marker unit will be at a predetermined depth below-ground and at a predetermined marker distance from the ground-anchored object.

The predetermined depth may be in the range of 0.1 m to the maximum reading depth of the remote reader, preferably is in the range of 0.1 m to 2 m, and more preferably in the range 0.1 m to 1.5 m.

The predetermined marker distance would generally be determined (and may have been recorded e.g. in an inventory database and/or the software of the remote reader) taking account of the nature of the ground, the nature of the ground anchored object and proximity of other objects (that may or may not be tagged). Usually, the marker distance would be in the range 0.1 m to 3 m, preferably 0.1 m to 2 m and more preferably 0.1 m to 1 m.

Preferably, the electronic marker unit comprises a radio frequency transponder. Particularly suitable transponders are radio frequency identity (RFID) transponders or tags. The frequency of operation of the transponder will generally be UHF (e.g. between 300 MHz and 3,000 MHz) although other frequency ranges may be used. Preferably, the transponder will be a passive transponder.

Usually, the electronic marker unit comprises a protective housing. Particularly suitable protective housings comprise a polymer, most preferably acrylonitrile butadiene styrene (ABS).

The method will usually involve using the electronic marker data to determine the identity and/or location of the ground-anchored object by searching a database (e.g. an inventory database) of ground-anchored objects using the electronic marker data.

In most embodiments, the ground-anchored object will be tagged with two or more electronic marker units (e.g. 2, 3, 4, 5 or 6 electronic marker units)

The method may involve providing and using two or more remote readers sequentially (i.e. one after the other) and/or simultaneously (i.e. two or more at the same time).

In a second aspect of the present invention, there is provided apparatus for tagging and identifying an above ground, ground-anchored object, the apparatus comprising, at least one electronic marker unit, the electronic marker unit being buried in the ground at a predetermined depth and at a predetermined marker distance from the ground-anchored object, and at least one remote reader adapted to obtain electronic marker data from the at least one electronic marker unit by interrogating a below-ground volume in the vicinity of the at least one remote reader.

In a third aspect of the present invention, there is provided a method of tagging an above-ground, ground-anchored object with an electronic marker unit, the method comprising locating and/or identifying the ground-anchored object to be tagged, providing at least one electronic marker unit, and burying the at least one electronic marker unit in the ground at a predetermined depth and at a predetermined marker distance from the ground-anchored object and, optionally at a predetermined bearing from the ground-anchored object.

So that the present invention may be more completely understood, reference is made to the accompanying drawings in which:

Figure 1a illustrates schematically apparatus being used in the method to identify a tree.

Figure 1b is a top view of the apparatus of Figure 1a.

5 Figure 2a illustrates schematically apparatus being used in the method to identify a road intersection.

Figure 2b illustrates a top view of the apparatus of Figure 2a.

Figure 3a illustrates schematically apparatus being used in the method to identify a road sign.

Figure 3b illustrates a top view of the apparatus of Figure 3a.

10 The reference numerals refer to:

10 apparatus,

20 electronic marker,

30 remote reader,

40 operator,

15 50 object (tree in Fig 1a and 1b, road intersection in Fig 2a and 2b and road sign in Fig 3a and 3b),

60 ground level.

Fig 1a and 1b show apparatus 10 being used in a method to identify a tree 50 which is ground anchored with a large portion of the tree 50 being above ground. The apparatus 10 comprises four electronic marker units 20 buried at a depth of d_1 (12 cm) below ground level 60 and in the case of
20 electronic marker unit 20 closest to the operator 40, at a marker distance d_2 from the tree 50 trunk. The other electronic marker units 20 are at the same (within measurement error which may be large with an irregular tree 50) marker distance d_2 . The four electronic marker units 20 are at compass bearings from the tree 50, at north, south, west and east (as shown in Fig 1b). The electronic marker units 20 contain a
15 passive UHF RFID transponder with a unique ID.

25 In the method to identify the tree 50 (e.g. by relating the tree 50 to records in an inventory database), the operator 40 operates the radio frequency remote reader 30 to interrogate a below ground volume at an object distance d_4 from the tree 50. The remote reader 30 obtains marker data from at least the RFID in the nearest electronic marker unit 20. Which of the electronic marker units 20 responded with data can be determined by the remote reader 30 from distance d_3 between the remote reader 30 and
30 electronic marker unit 20 (itself determined using detected signal level) and the height d_5 of the remote

reader 30 above ground 60. The inventory database (not shown) contains information on the tree 50 and bearing, d_1 , d_2 and ID of the RFIDs in the electronic marker units 20. Together with the returned marker data and d_4 , d_3 and, optionally, d_5 it is possible to uniquely identify the tree 50 and relate it to other data in the database.

5 As an alternative to compass bearing, the bearing of the ground anchored object 50 from each of the electronic marker units 20 may be determined by the relative position of two or more of the electronic marker units 20 to the ground anchored object 50.

10 Figure 2a and 2b illustrate apparatus for use in a similar method to identify a road intersection 50. Generally the same method is used as in Figure 1a, b with the same result (the same reference numerals refer to the same feature with the exception of road intersection 50). In the case of Fig 2a and 2b, there are two electronic marker units 20 situated on a bearing NE and SE of the centre of the road intersection 50. Generally the same procedure as for the tree method may be adopted with the same result of uniquely identifying the road intersection 50.

15 Figure 3a and 3b illustrate apparatus for use in a similar method to identify a road sign 50. Generally the same method is used as in Figures 1a, b and 2a, b with the same result (the same reference numerals refer to the same feature with the exception of road sign 50). In the case of Fig 3a and 3b, there are three electronic marker units 20, two situated at a marker distance d_2 on a bearing N and E of the road sign 50 and one S of the road sign 50 at a greater marker distance than for the other electronic marker units 20. Generally the same procedure as for the tree or road intersection method may be adopted with
20 the same result of uniquely identifying the road sign.

Claims

1. A method of identifying an above-ground, ground-anchored object, the ground-anchored object being tagged with at least one below-ground electronic marker unit, the method comprising
- 5 providing a remote reader,
- using the remote reader to interrogate a below-ground volume, thereby obtaining electronic marker data from one or more electronic marker units in the below-ground volume, and
- using the electronic marker data to determine the identity and/or location of the ground-anchored object.
- 10 2. A method as claimed in claim 1, wherein the ground-anchored object is selected from a tree, a road intersection, or an object of road furniture.
3. A method as claimed in claim 2, wherein the road furniture is selected from a bench, a traffic barrier, a bollard, a post box, a streetlamp, a traffic light, or a traffic sign.
4. A method as claimed in any one of the preceding claims, further comprising a step, before using the remote reader to interrogate a below-ground volume, of locating an above-ground, ground-anchored
- 15 object.
5. A method as claimed in claim 4, wherein using the remote reader to interrogate the below-ground volume comprises using the remote reader at a predetermined object distance from the ground-anchored object to interrogate a below-ground volume.
- 20 6. A method as claimed in either claim 4 or claim 5, wherein using the remote reader to interrogate the below-ground volume comprises using the remote reader at a predetermined bearing from the ground-anchored object to interrogate a below-ground volume.
7. A method as claimed in any one of the preceding claims, wherein the at least one electronic marker unit is at a predetermined depth below-ground and at a predetermined marker distance from the ground-
- 25 anchored object.
8. A method as claimed in claim 7, wherein the predetermined depth is in the range of 0.1 m to the maximum reading depth of the remote reader, preferably is in the range of 0.1 m to 2 m, and more preferably in the range 0.1 m to 1.5 m.
9. A method as claimed in any one of the preceding claims, wherein the electronic marker unit comprises
- 30 a radio frequency passive transponder.

10. A method as claimed in any one of the preceding claims, wherein the electronic marker unit comprises a protective housing.
11. A method as claimed in claim 10, wherein the protective housing comprises a polymer, preferably acrylonitrile butadiene styrene.
- 5 12. A method as claimed in any one of the preceding claims, wherein using the electronic marker data to determine the identity and/or location of the ground-anchored object comprises searching a database of ground-anchored objects using the electronic marker data.
13. A method as claimed in any one of the preceding claims, wherein the ground-anchored object is tagged with two or more electronic marker units.
- 10 14. Apparatus for tagging and identifying an above ground, ground-anchored object, the apparatus comprising,
- at least one electronic marker unit, the electronic marker unit being buried in the ground at a predetermined depth and at a predetermined marker distance from the ground-anchored object, and
- at least one remote reader adapted to obtain electronic marker data from the at least one electronic
- 15 marker unit by interrogating a below-ground.
15. A method of tagging an above-ground, ground-anchored object with an electronic marker unit, the method comprising
- locating and/or identifying the ground-anchored object to be tagged,
- providing at least one electronic marker unit, and
- 20 burying the at least one electronic marker unit in the ground at a predetermined depth and at a predetermined marker distance from the ground-anchored object and, optionally, at a predetermined bearing from the ground-anchored object.

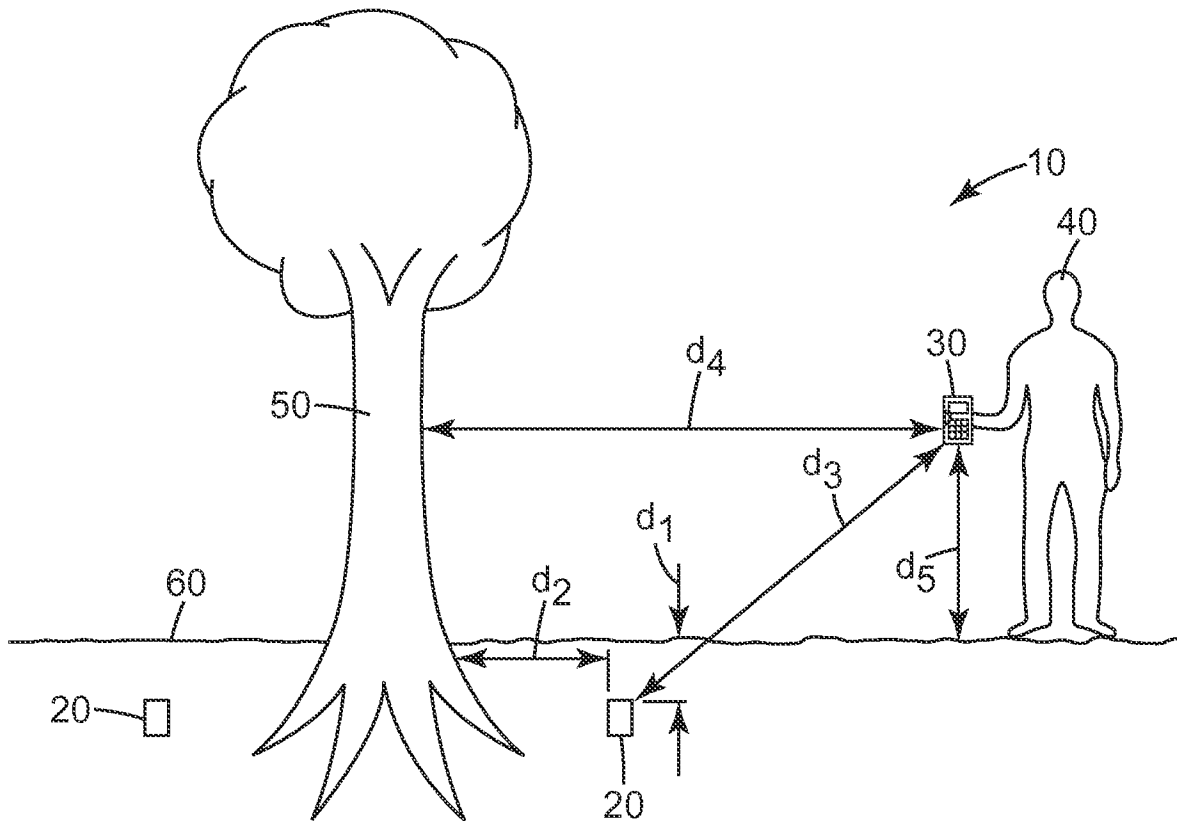

Fig. 1a

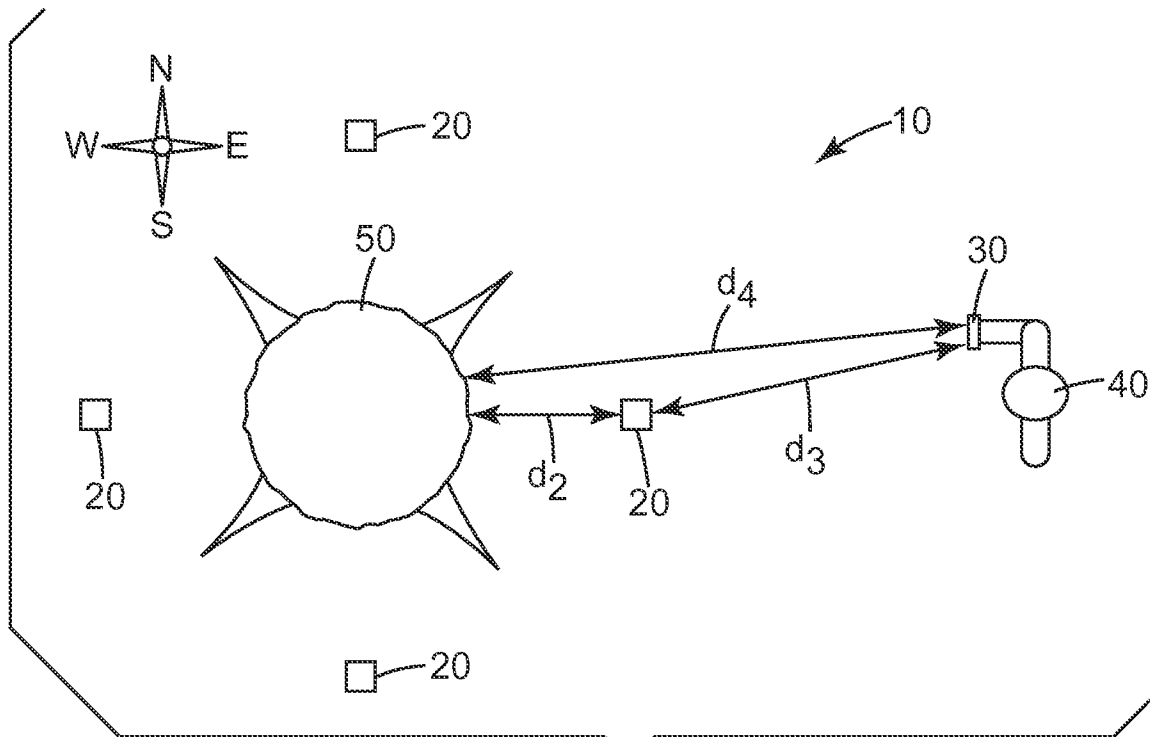

Fig. 1b

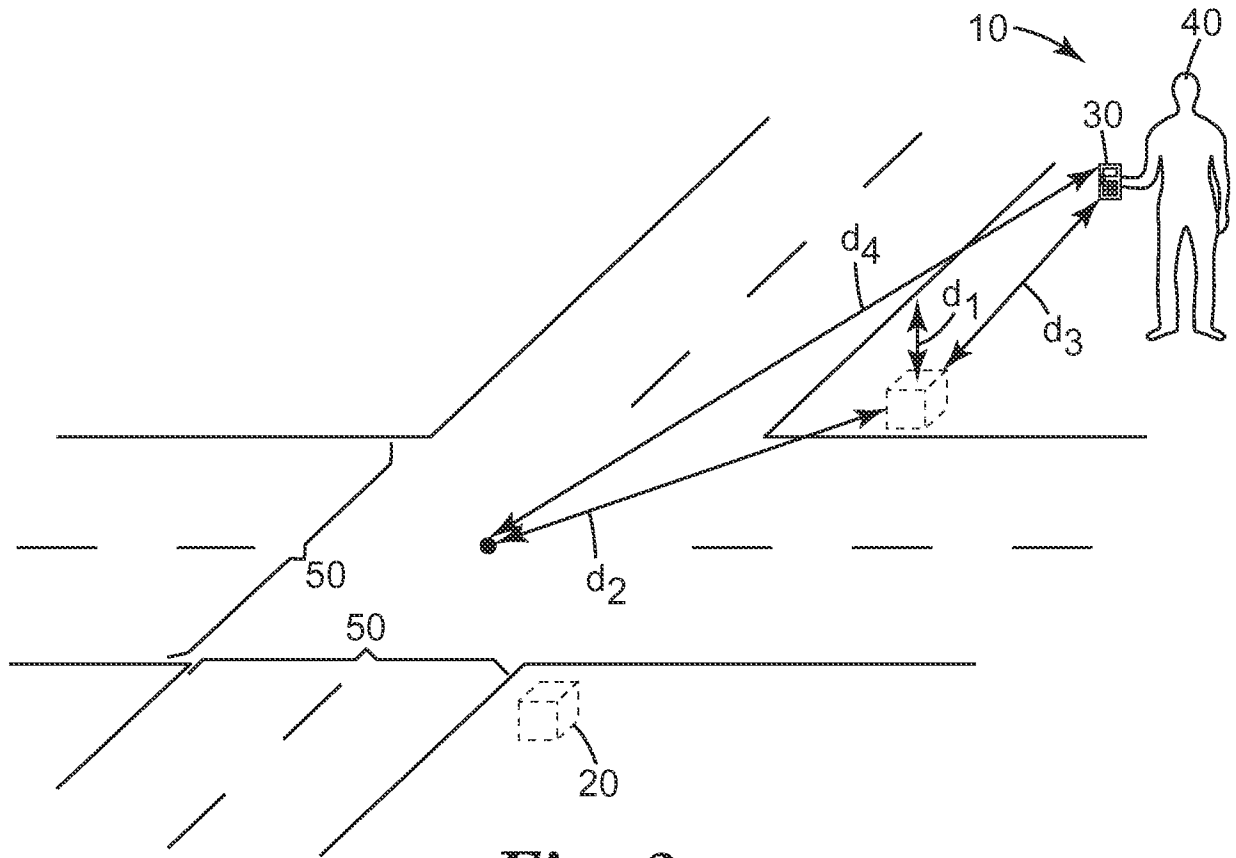

Fig. 2a

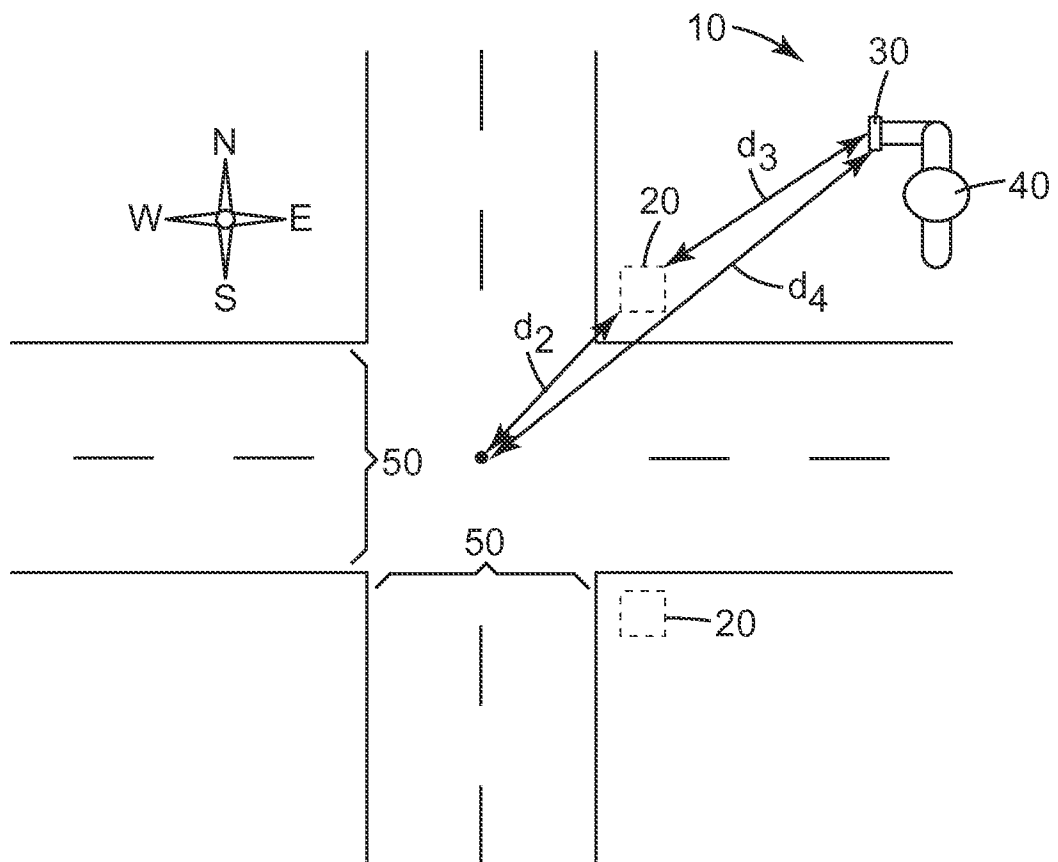

Fig. 2b

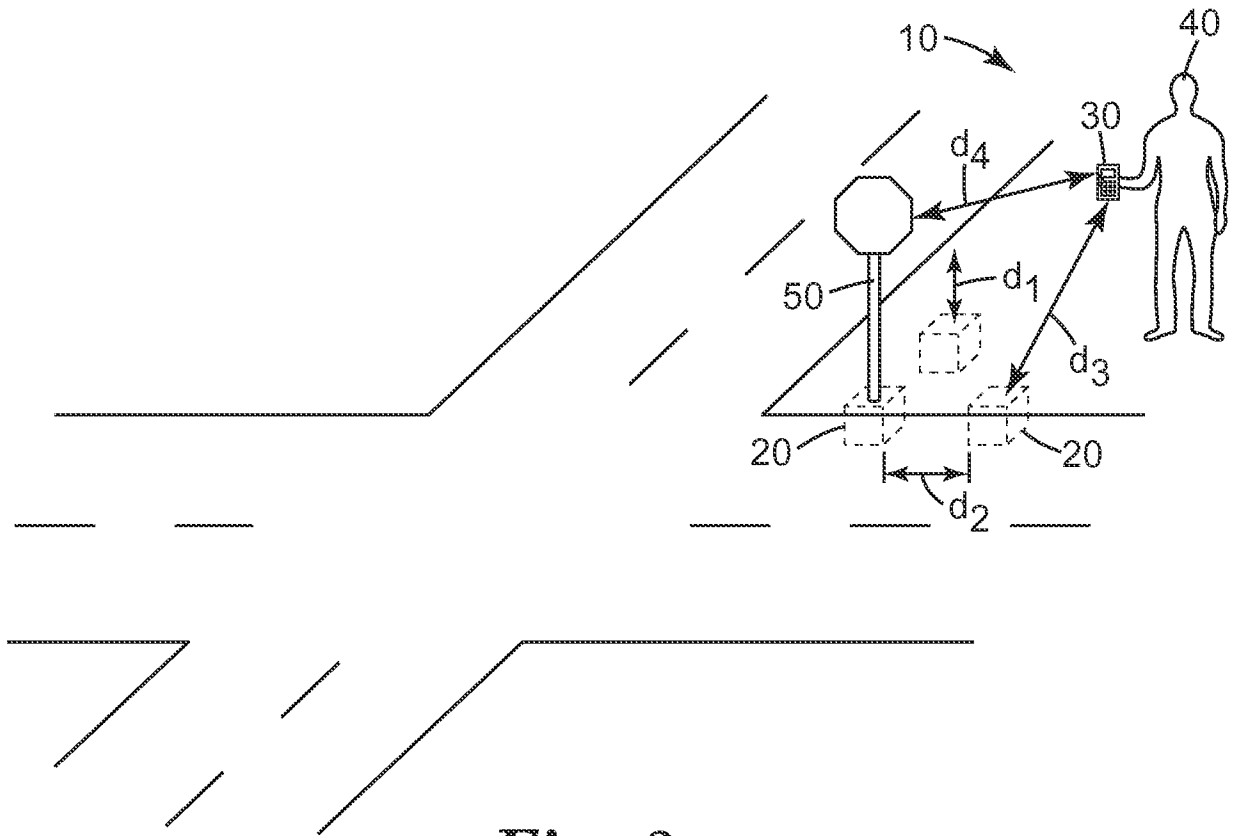

Fig. 3a

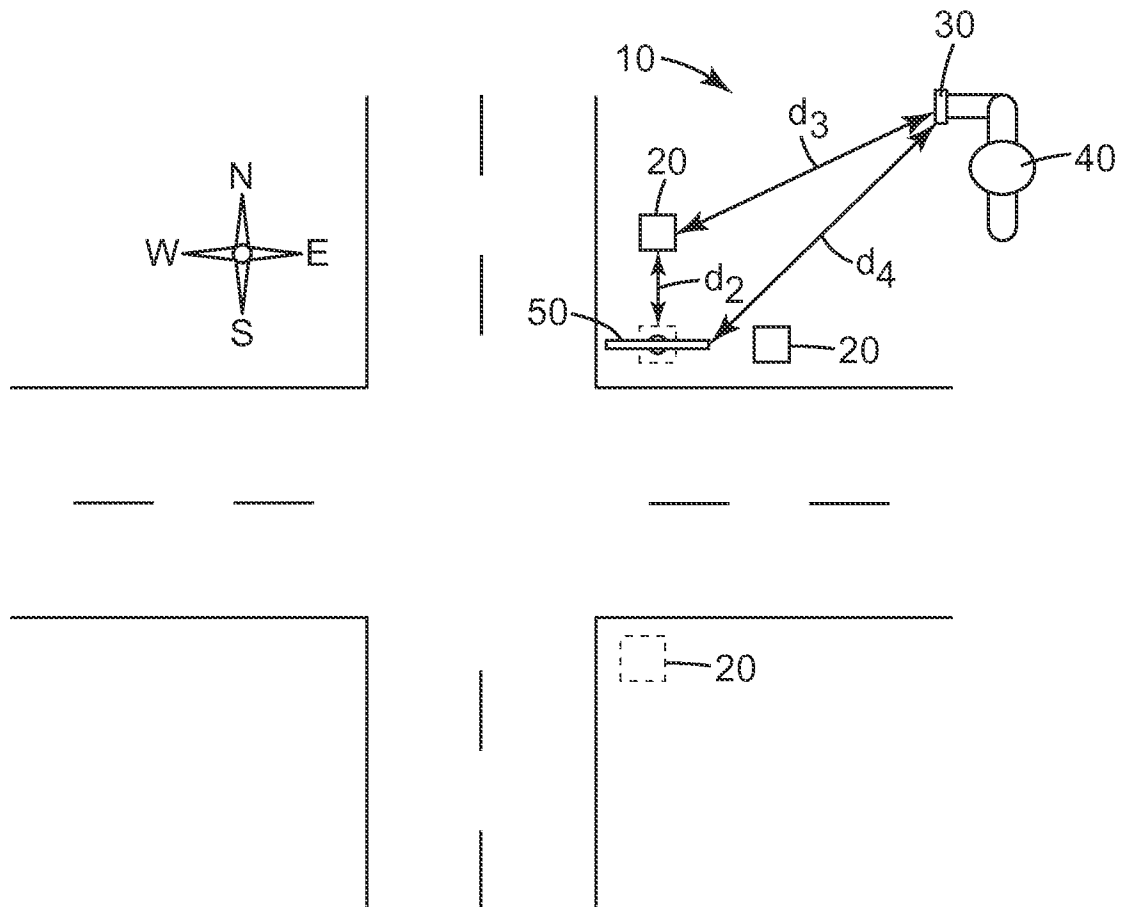

Fig. 3b

INTERNATIONAL SEARCH REPORT

International application No
PCT/US2014/014011

A. CLASSIFICATION OF SUBJECT MATTER
INV. G06Q10/08 G06Q50/28
ADD.
According to International Patent Classification (IPC) or to both national classification and IPC

B. FIELDS SEARCHED
Minimum documentation searched (classification system followed by classification symbols)
G06Q
Documentation searched other than minimum documentation to the extent that such documents are included in the fields searched

Electronic data base consulted during the international search (name of data base and, where practicable, search terms used)
EPO-Internal, WPI Data

C. DOCUMENTS CONSIDERED TO BE RELEVANT		
Category*	Citation of document, with indication, where appropriate, of the relevant passages	Relevant to claim No.
X	US 2009/085741 A1 (RAVI RANJITH [US] ET AL) 2 April 2009 (2009-04-02) abstract paragraphs [0001] - [0013]; figures 1,2 paragraph [0058] paragraph [0121]; figure 23 -----	1-15
X	US 2011/148584 A1 (LEE KYONG HEE [KR] ET AL) 23 June 2011 (2011-06-23) abstract paragraphs [0003] - [0011] paragraphs [0038] - [0049]; figures 5a,5b -----	1-15
A	JP 2010 224819 A (PANASONIC ELEC WORKS CO LTD) 7 October 2010 (2010-10-07) abstract paragraphs [0007], [0008] ----- -/--	1-15

Further documents are listed in the continuation of Box C.

See patent family annex.

* Special categories of cited documents :

- "A" document defining the general state of the art which is not considered to be of particular relevance
- "E" earlier application or patent but published on or after the international filing date
- "L" document which may throw doubts on priority claim(s) or which is cited to establish the publication date of another citation or other special reason (as specified)
- "O" document referring to an oral disclosure, use, exhibition or other means
- "P" document published prior to the international filing date but later than the priority date claimed

"T" later document published after the international filing date or priority date and not in conflict with the application but cited to understand the principle or theory underlying the invention

"X" document of particular relevance; the claimed invention cannot be considered novel or cannot be considered to involve an inventive step when the document is taken alone

"Y" document of particular relevance; the claimed invention cannot be considered to involve an inventive step when the document is combined with one or more other such documents, such combination being obvious to a person skilled in the art

"&" document member of the same patent family

Date of the actual completion of the international search 1 April 2014	Date of mailing of the international search report 15/04/2014
Name and mailing address of the ISA/ European Patent Office, P.B. 5818 Patentlaan 2 NL - 2280 HV Rijswijk Tel. (+31-70) 340-2040, Fax: (+31-70) 340-3016	Authorized officer Dedek, Frédéric

INTERNATIONAL SEARCH REPORT

International application No
PCT/US2014/014011

C(Continuation). DOCUMENTS CONSIDERED TO BE RELEVANT		
Category*	Citation of document, with indication, where appropriate, of the relevant passages	Relevant to claim No.
A	JP 2005 046607 A (RAILWAY TECHNICAL RES INST) 24 February 2005 (2005-02-24) abstract paragraph [0013]	1
A	----- EP 1 988 491 A1 (TOYO SEIKAN KAISHA LTD [JP]) 5 November 2008 (2008-11-05) abstract paragraph [0255] -----	11

INTERNATIONAL SEARCH REPORT

Information on patent family members

International application No

PCT/US2014/014011

Patent document cited in search report	Publication date	Patent family member(s)	Publication date
US 2009085741	A1	02-04-2009	CN 101809592 A 18-08-2010
			EP 2195766 A1 16-06-2010
			US 2009085741 A1 02-04-2009
			WO 2009042578 A1 02-04-2009

US 2011148584	A1	23-06-2011	KR 20110069973 A 24-06-2011
			US 2011148584 A1 23-06-2011

JP 2010224819	A	07-10-2010	NONE

JP 2005046607	A	24-02-2005	JP 4396891 B2 13-01-2010
			JP 2005046607 A 24-02-2005

EP 1988491	A1	05-11-2008	CN 101390111 A 18-03-2009
			CN 101948025 A 19-01-2011
			CN 102514827 A 27-06-2012
			EP 1988491 A1 05-11-2008
			EP 2077519 A2 08-07-2009
			EP 2690586 A1 29-01-2014
			KR 20080098367 A 07-11-2008
			KR 20130041321 A 24-04-2013
			KR 20130041322 A 24-04-2013
			US 2010219252 A1 02-09-2010
			US 2014001270 A1 02-01-2014
WO 2007097385 A1 30-08-2007			
