



(86) Date de dépôt PCT/PCT Filing Date: 2011/06/29
 (87) Date publication PCT/PCT Publication Date: 2012/01/05
 (85) Entrée phase nationale/National Entry: 2012/12/05
 (86) N° demande PCT/PCT Application No.: JP 2011/065410
 (87) N° publication PCT/PCT Publication No.: 2012/002563
 (30) Priorités/Priorities: 2010/06/30 (JP2010-149650);
 2011/06/28 (JP2011-142507)

(51) Cl.Int./Int.Cl. *C22C 38/00* (2006.01),
C22C 38/32 (2006.01), *C22C 38/54* (2006.01),
C21D 8/02 (2006.01)
 (71) Demandeur/Applicant:
 JFE STEEL CORPORATION, JP
 (72) Inventeurs/Inventors:
 UEDA, KEIJI, JP;
 SUZUKI, SHINICHI, JP
 (74) Agent: ROBIC

(54) Titre : TOLE D'ACIER RESISTANT A L'USURE AVEC D'EXCELLENTE PROPRIETES EN TERMES DE TENACITE
 D'UNE PIECE SOUDEE ET DE RESISTANCE A LA DESTRUCTION D'UNE ENVELOPPE
 (54) Title: ABRASION RESISTANT STEEL PLATE WHICH EXHIBITS EXCELLENT WELD TOUGHNESS AND
 EXCELLENT DELAYED FRACTURE RESISTANCE

(57) **Abrégé/Abstract:**

Disclosed is a wear-resistant steel sheet which has excellent toughness of a multi-layer-welded part and excellent lagging destruction resistance properties and is therefore suitable for a construction machine, an industrial machine and the like. Specifically disclosed is a steel sheet which contains, in mass%, 0.20-0.30% of C, 0.05-1.0% of Si, 0.40-1.2% of Mn, 0.010% or less of P, 0.005% or less of S, 0.40-1.5% of Cr, 0.005-0.025% of Nb, 0.05-1.0% of Mo, 0.005-0.03% of Ti, 0.1% or less of Al, 0.01% or less of N and 0.0003-0.0020% of B, optionally contains at least one element selected from W, Cu, Ni, V, REM, Ca and Mg, and fulfils the requirements represented by the following formulae: $DI^* (= 33.85 \times (0.1 \times C)^{0.5} \times (0.7 \times Si + 1) \times (3.33 \times Mn + 1) \times (0.35 \times Cu + 1) \times (0.36 \times Ni + 1) \times (2.16 \times Cr + 1) \times (3 \times Mo + 1) \times (1.75 \times V + 1) \times (1.5 \times W + 1))$: 45-180 and $C + Mn/4 - Cr/3 + 10P \leq 0.47$, wherein the microstructure of the steel sheet contains martensite as the matrix phase.



(12) 特許協力条約に基づいて公開された国際出願

(19) 世界知的所有権機関
国際事務局(43) 国際公開日
2012年1月5日(05.01.2012)(10) 国際公開番号
WO 2012/002563 A1

- (51) 国際特許分類:
C22C 38/00 (2006.01) C22C 38/54 (2006.01)
C22C 38/32 (2006.01) C21D 8/02 (2006.01)
- (21) 国際出願番号: PCT/JP2011/065410
- (22) 国際出願日: 2011年6月29日(29.06.2011)
- (25) 国際出願の言語: 日本語
- (26) 国際公開の言語: 日本語
- (30) 優先権データ:
特願 2010-149650 2010年6月30日(30.06.2010) JP
特願 2011-142507 2011年6月28日(28.06.2011) JP
- (71) 出願人(米国を除く全ての指定国について): JFE
スチール株式会社(JFE STEEL CORPORATION)
[JP/JP]; 〒1000011 東京都千代田区内幸町二丁目
2番3号 Tokyo (JP).
- (72) 発明者; および
- (75) 発明者/出願人(米国についてのみ): 植田 圭治
(UEDA, Keiji) [JP/JP]; 〒1000011 東京都千代田区
内幸町二丁目2番3号 JFE スチール株式会社知
的財産部内 Tokyo (JP). 鈴木 伸一(SUZUKI,
Shinichi) [JP/JP]; 〒1000011 東京都千代田区内幸
町二丁目2番3号 JFE スチール株式会社知的財
産部内 Tokyo (JP).
- (74) 代理人: 落合 憲一郎(OCHIAI, Kenichiro); 〒
1030027 東京都中央区日本橋二丁目1番10号
- 柳屋ビルディング7階 JFE テクノリサーチ株式
会社特許出願部内 Tokyo (JP).
- (81) 指定国(表示のない限り、全ての種類の国内保
護が可能): AE, AG, AL, AM, AO, AT, AU, AZ, BA,
BB, BG, BH, BR, BW, BY, BZ, CA, CH, CL, CN, CO,
CR, CU, CZ, DE, DK, DM, DO, DZ, EC, EE, EG, ES, FI,
GB, GD, GE, GH, GM, GT, HN, HR, HU, ID, IL, IN, IS,
KE, KG, KM, KN, KP, KR, KZ, LA, LC, LK, LR, LS,
LT, LU, LY, MA, MD, ME, MG, MK, MN, MW, MX,
MY, MZ, NA, NG, NI, NO, NZ, OM, PE, PG, PH, PL,
PT, RO, RS, RU, SC, SD, SE, SG, SK, SL, SM, ST, SV,
SY, TH, TJ, TM, TN, TR, TT, TZ, UA, UG, US, UZ, VC,
VN, ZA, ZM, ZW.
- (84) 指定国(表示のない限り、全ての種類の広域保
護が可能): ARIPO (BW, GH, GM, KE, LR, LS, MW,
MZ, NA, SD, SL, SZ, TZ, UG, ZM, ZW), ユーラシア
(AM, AZ, BY, KG, KZ, MD, RU, TJ, TM), ヨーロッパ
(AL, AT, BE, BG, CH, CY, CZ, DE, DK, EE, ES, FI, FR,
GB, GR, HR, HU, IE, IS, IT, LT, LU, LV, MC, MK, MT,
NL, NO, PL, PT, RO, RS, SE, SI, SK, SM, TR), OAPI
(BF, BJ, CF, CG, CI, CM, GA, GN, GQ, GW, ML, MR,
NE, SN, TD, TG).
- 添付公開書類:
— 国際調査報告(条約第21条(3))

(54) Title: WEAR-RESISTANT STEEL SHEET HAVING EXCELLENT WELDED PART TOUGHNESS AND LAGGING DE-
STRUCTION RESISTANCE PROPERTIES

(54) 発明の名称: 溶接部靱性と耐遅れ破壊特性に優れた耐磨耗鋼板

(57) Abstract: Disclosed is a wear-resistant steel sheet which has excellent toughness of a multi-layer-welded part and excellent lagging destruction resistance properties and is therefore suitable for a construction machine, an industrial machine and the like. Specifically disclosed is a steel sheet which contains, in mass%, 0.20-0.30% of C, 0.05-1.0% of Si, 0.40-1.2% of Mn, 0.010% or less of P, 0.005% or less of S, 0.40-1.5% of Cr, 0.005-0.025% of Nb, 0.05-1.0% of Mo, 0.005-0.03% of Ti, 0.1% or less of Al, 0.01% or less of N and 0.0003-0.0020% of B, optionally contains at least one element selected from W, Cu, Ni, V, REM, Ca and Mg, and fulfils the requirements represented by the following formulae: $DI^* (= 33.85 \times (0.1 \times C)^{0.5} \times (0.7 \times Si + 1) \times (3.33 \times Mn + 1) \times (0.35 \times Cu + 1) \times (0.36 \times Ni + 1) \times (2.16 \times Cr + 1) \times (3 \times Mo + 1) \times (1.75 \times V + 1) \times (1.5 \times W + 1))$; 45-180 and $C + Mn/4 - Cr/3 + 10P \leq 0.47$, wherein the microstructure of the steel sheet contains martensite as the matrix phase.

(57) 要約: 建設機械、産業機械等に好適な多層盛溶接部の靱性と耐遅れ破壊特性に優れた耐磨耗鋼板を提供する。具体的には、mass%で、C: 0.20~0.30%、Si: 0.05~1.0%、Mn: 0.40~1.2%、P: 0.010%以下、S: 0.005%以下、Cr: 0.40~1.5%、Nb: 0.005~0.025%、Mo: 0.05~1.0%、Ti: 0.005~0.03%、Al: 0.1%以下、N: 0.01%以下、B: 0.0003~0.0020%を含有し、必要に応じてW、Cu、Ni、V、REM、Ca、Mgの1種または2種以上を含有し、 $DI^* (= 33.85 \times (0.1 \times C)^{0.5} \times (0.7 \times Si + 1) \times (3.33 \times Mn + 1) \times (0.35 \times Cu + 1) \times (0.36 \times Ni + 1) \times (2.16 \times Cr + 1) \times (3 \times Mo + 1) \times (1.75 \times V + 1) \times (1.5 \times W + 1))$: 45~180、 $C + Mn/4 - Cr/3 + 10P \leq 0.47$ でマイクロ組織がマルテンサイトを基相とする鋼板である。

WO 2012/002563 A1

2011/09/17

Description

[Title of the Invention]

ABRASION RESISTANT STEEL PLATE WHICH EXHIBITS EXCELLENT
WELD TOUGHNESS AND EXCELLENT DELAYED FRACTURE RESISTANCE

[Technical Field]

[0001]

The present invention relates to an abrasion resistant steel plate or steel sheet having a plate thickness of 4 mm or more preferably used in construction machines, industrial machines, shipbuilding, steel pipes, civil engineering, architecture or the like, and more particularly to an abrasion resistant steel plate or steel sheet which exhibits excellent toughness and excellent delayed fracture resistance of a multi pass weld.

[Background Art]

[0002]

When a hot-rolled steel plate is employed for forming steel structural products, machines, devices or the like in construction machines, industrial machines, shipbuilding, steel pipes, civil engineering, architecture or the like, there may be a case where the steel plates are required to possess abrasion resistant property. Conventionally, to impart excellent abrasion resistant property to a steel material, hardness is increased in general, and hardness of the steel

material can be remarkably enhanced by forming the steel material into the martensite single phase microstructure. The increase of an amount of solid solution carbon is also effective for enhancing hardness of martensite microstructure per se.

[0003]

Accordingly, the abrasion resistant steel plate exhibits high cold cracking susceptibility so that the steel plate exhibits inferior weld toughness in general whereby when the abrasion resistant steel plate is used in forming the welded steel structure, in general, the abrasion resistant steel plate is laminated to a surface of a steel member which is brought into contact with rock, earth and sand or the like as a liner. For example, with respect to a vessel of a damped motor lorry, there has been known a case where the vessel is assembled by welding using mild steel and, thereafter, an abrasion resistant steel plate is laminated to only a front surface of the vessel which is brought into contact with earth and sand.

[0004]

However, in the manufacturing method in which the abrasion resistant steel plate is laminated to the welded steel structure after the welded steel structure is assembled, labor for the manufacture and a manufacturing cost are increased. Accordingly, there has been a demand for an abrasion resistant steel plate which is excellent in weldability and weld toughness and can be used as a strength member of the welded

steel structure, and such an abrasion resistant steel plate has been proposed in patent documents 1 to 5, for example.

Patent document 1 relates to an abrasion resistant steel plate which exhibits excellent delayed fracture resistance and a method of manufacturing the abrasion resistant steel plate. In patent document 1, there is the description that, to improve the delayed fracture resistance, steel which further contains one, two or more kinds of components selected from a group consisting of Cu, V, Ti, B and Ca in the composition of a type containing low-Si, low-P, low-S, Cr, Mo and Nb is subjected to direct quenching (hereinafter also referred to as DQ), and tempering is performed when necessary.

[0005]

Patent document 2 relates to steel having high abrasion resistant property and a method of manufacturing a steel product. In patent document 2, there is described steel which has the composition composed of a 0.24 to 0.3C-Ni, Cr, Mo, B system, satisfies a parameter formula constituted of contents of these elements, and includes martensite containing 5 to 15 volume% of austenite or martensitic structure and bainitic structure thus enhancing abrasion resistant property. Patent document 2 also describes that the steel having the above-mentioned components is cooled at a cooling rate of 1°C/sec or more at a temperature between an austenitizing temperature and 450°C.

[0006]

Patent document 3 relates to an abrasion resistant steel material which exhibits excellent toughness and excellent delayed fracture resistance and a method of manufacturing the abrasion resistant steel material. In patent document 3, there is described a steel material which has the composition containing Cr, Ti, and B as indispensable components, wherein a surface layer is formed of tempered martensite, an internal part is formed of tempered martensite and tempered lower bainitic structure, and an aspect ratio of prior austenite grain diameter between the wall thickness direction and the rolling direction is defined. Patent document 3 also describes that the steel having the content composition is subject to hot rolling at a temperature of 900°C or below and at a cumulative reduction ratio of 50% or more and, thereafter, is directly quenched and tempered.

[0007]

Patent document 4 relates to an abrasion resistant steel material which exhibits excellent toughness and excellent delayed fracture resistance and a method of manufacturing the abrasion resistant steel material. In patent document 4, there is described a steel material which has the composition containing Cr, Ti and B as indispensable components, wherein a surface layer is formed of martensite, and an internal part is formed of the mixed structure of martensite and lower

bainitic structure or lower bainitic single-phase structure, and an elongation rate of prior austenite grains expressed by an aspect ratio between prior austenite grain diameter at a plate thickness center portion and prior austenite grain diameter in the rolling direction is defined. Patent document 4 also describes that the steel having the composition is subjected to hot rolling at a temperature of 900°C or below and at a cumulative reduction ratio of 50% or more and, thereafter, is directly quenched.

[0008]

Patent document 5 relates to abrasion resistant steel which exhibits excellent weldability, excellent abrasion resistant property and excellent corrosion resistance, and a method of manufacturing the abrasion resistant steel. In patent document 5, there is described steel which contains 4 to 9 mass% of Cr as an indispensable element, contains one or two kinds of Cu and Ni and satisfies a parameter formula constituted of contents of specific components. Patent document 5 also describes that the steel having the composition is subjected to hot rolling at a temperature of 950°C or below and at a cumulative reduction ratio of 30% or more and, thereafter, the steel is reheated at a temperature of Ac3 or more and is quenched.

[Prior Art Literature]

[Patent Document]

[0009]

[Patent Document 1] JP-A-5-51691

[Patent Document 2] JP-A-8-295990

[Patent Document 3] JP-A-2002-115024

[Patent Document 4] JP-A-2002-80930

[Patent Document 5] JP-A-2004-162120

[Summary of the Invention]

[Task to be Solved by the Invention]

[0010]

In case of a weld joint using a steel plate having a plate thickness of 4 mm or more, it is often the case that the weld joint is formed by multi pass welding. However, in a weld, a bond area formed by a preceding weld pass is reheated by succeeding welding so that a region where toughness is remarkably deteriorated appears. Particularly, in an abrasion resistant steel plate, when a bond area formed by welding for forming a first layer is reheated to a temperature around 300°C due to succeeding welding, toughness is remarkably deteriorated due to low-temperature tempering embrittlement.

[0011]

It is thought that low-temperature tempering embrittlement is brought about by a synergistic action between a morphology change of carbide in martensite and the intergranular segregation of impurity elements or the like. In a bond area which has coarse grain particles and contains

a large quantity of solid solution N, the low-temperature tempering embrittlement becomes conspicuous. It has been pointed out that delayed fracture is liable to occur in a region which is reheated to such a low-temperature tempering embrittlement temperature.

[0012]

Patent documents 1 and 2 fail to describe the enhancement of weld toughness in an abrasion resistant steel, and patent documents 3 and 4 also define the microstructure aiming at the enhancement of toughness of a base material. Although patent document 5 studies weldability and abrasion resistant property of a weld, the study does not aim at the enhancement of weld toughness. That is, the abrasion resistant steels proposed in patent documents 1 to 5 and the like are less than optimal with respect to the improvement of both weld toughness and delayed fracture resistance of a multi pass weld.

Accordingly, it is an object of the present invention to provide an abrasion resistant steel plate which exhibits excellent toughness of a multi pass weld and excellent delayed fracture resistance without inducing lowering of productivity and the increase in a manufacturing cost.

[Means for Solving the Problem]

[0013]

To achieve the above-mentioned object, inventors of the present invention have made extensive studies on various

factors which decide chemical components of a steel plate, a method of manufacturing the steel plate and the microstructure of the steel plate so as to secure toughness of a multi pass weld and delayed fracture resistance with respect to an abrasion resistant steel plate, and have made following findings.

[0014]

1. To secure excellent abrasion resistant property, it is indispensable to form the base microstructure or the main microstructure (also referred to as a base phase or a main phase) of the steel plate into martensite. For this end, it is important to strictly control the chemical composition of the steel plate thus securing quenching property.

2. To achieve the excellent toughness of a multi pass weld, it is necessary to suppress grain particles in a welded heat affected zone from becoming coarse, and for this end, it is effective to make use of a pinning effect by dispersing fine precipitates in the steel plate. Accordingly, a control of Ti, N is important.

3. The reduction of solid solution N in a bond area forming an initial layer is effective for suppressing low-temperature tempering embrittlement caused by succeeding welding. For this end, it is important to strictly control B for fixing solid solution N as BN.

4. To secure the excellent toughness and to suppress

delayed fracture in a low-temperature tempering embrittlement temperature area of the welded heat affected zone, it is important to properly control quantities of alloy elements such as C, Mn, Cr, Mo, P.

[0015]

The present invention has been made by further studying the above-mentioned findings. That is, the present invention is directed to:

1. An abrasion resistant steel plate having excellent weld toughness and excellent delayed fracture resistance, and having a composition containing by mass% 0.20 to 0.30% C, 0.05 to 1.0% Si, 0.40 to 1.2% Mn, 0.010% or less P, 0.005% or less S, 0.40 to 1.5% Cr, 0.05 to 1.0% Mo, 0.005 to 0.025% Nb, 0.005 to 0.03% Ti, 0.1% or less Al, 0.0015 to 0.0060% N, 0.0003 to 0.0020% B, and Fe and unavoidable impurities as a balance, wherein hardenability index DI* expressed by a formula (1) is 45 or more, and a base phase of the microstructure is formed of martensite.

$$DI^* = 33.85 \times (0.1 \times C)^{0.5} \times (0.7 \times Si + 1) \times (3.33 \times Mn + 1) \times (0.35 \times Cu + 1) \\ \times (0.36 \times Ni + 1) \times (2.16 \times Cr + 1) \times (3 \times Mo + 1) \times (1.75 \times V + 1) \times (1.5 \times W + 1) \\ \dots (1),$$

wherein the respective element symbols are contents (mass%) of the elements.

2. The abrasion resistant steel plate having excellent weld toughness and excellent delayed fracture resistance

described in 1, wherein the steel composition further contains by mass% 0.05 to 1.0% W.

3. The abrasion resistant steel plate having excellent weld toughness and excellent delayed fracture resistance described in 1 or 2, wherein the steel composition further contains by mass% one, two or more kinds of components selected from a group consisting of 1.5% or less Cu, 2.0% or less Ni, and 0.1% or less V.

4. The abrasion resistant steel plate having excellent weld toughness and excellent delayed fracture resistance described in any one of 1 to 3, wherein the steel composition further contains by mass% one, two or more kinds of components selected from a group consisting of 0.008% or less REM, 0.005% or less Ca, and 0.005% or less Mg.

5. The abrasion resistant steel plate having excellent weld toughness and excellent delayed fracture resistance described in any one of 1 to 4, wherein surface hardness of the steel plate is 400 HBW10/3000 or more in Brinell hardness.

6. The abrasion resistant steel plate having excellent weld toughness and excellent delayed fracture resistance described in any one of 1 to 5, wherein hardenability index DI* is 180 or less.

7. The abrasion resistant steel plate having excellent weld toughness and excellent delayed fracture resistance described in any one of 1 to 6, wherein the steel plate satisfies

a following formula (2).

$$C+Mn / 4-Cr / 3+10P \leq 0.47 \dots (2),$$

wherein the respective element symbols are contents (mass%) of the elements.

[Advantage of the Invention]

[0016]

According to the present invention, it is possible to acquire the abrasion resistant steel plate having excellent toughness and excellent delayed fracture resistance at a multi pass weld. The present invention largely contributes to the enhancement of manufacturing efficiency and safety at the time of manufacturing a steel structure thus acquiring an industrially remarkable effect.

[Brief Description of the Drawings]

[0017]

Fig. 1 is a view for explaining a T shape fillet weld cracking test.

Fig. 2 is a view showing a position where a Charpy impact test piece is taken from a weld.

[Mode for Carrying Out the Invention]

[0018]

The present invention defines the composition and the microstructure.

[Composition]

In the explanation made hereinafter, % indicates mass%.

C: 0.20 to 0.30%

C is an important element for increasing hardness of martensite and for allowing the steel plate to secure the excellent abrasion resistant property. It is necessary for the steel plate to contain 0.20% or more C to acquire such effects. On the other hand, when the content of C exceeds 0.30%, not only weldability is deteriorated but also toughness of a bond area of a multi pass weld is deteriorated due to low-temperature tempering embrittlement. Accordingly, content of C is limited to a value which falls within a range from 0.20 to 0.30%. The content of C is preferably limited to a value which falls within a range from 0.20 to 0.28%.

[0019]

Si: 0.05 to 1.0%

Si acts as a deoxidizing agent, and not only Si is necessary for steel making but also Si has an effect of increasing hardness of a steel plate by solid solution strengthening where Si is present in steel in a solid solution state. Further, Si has an effect of suppressing the deterioration of toughness of a bond area of a multi pass weld due to low-temperature tempering embrittlement. It is necessary for the steel plate to contain 0.05% or more Si to acquire such an effect. On the other hand, when the content of Si exceeds 1.0%, toughness of the multi pass welded heat

affected zone is remarkably deteriorated. Accordingly, the content of Si is limited to a value which falls within a range from 0.05 to 1.0%. The content of Si is preferably limited to a value which falls within a range from 0.07 to 0.5%.

[0020]

Mn: 0.40 to 1.2%

Mn has an effect of increasing hardenability of steel, and it is necessary for the steel plate to contain 0.40% or more Mn to secure hardness of a base material. On the other hand, when the content of Mn exceeds 1.2%, not only toughness, ductility and weldability of the base material are deteriorated, but also intergranular segregation of P is accelerated thus accelerating the generation of delayed fracture. Accordingly, the content of Mn is limited to a value which falls within a range from 0.40 to 1.2%. The content of Mn is preferably limited to a value which falls within a range from 0.40 to 1.1%.

[0021]

P: 0.010% or less

When the content of P exceeds 0.010%, P is segregated in a grain boundary, the segregated P becomes an initiation point of delayed fracture, and deteriorates toughness of a multi pass weld. Accordingly, an upper limit of the content of P is set to 0.010% and it is desirable that the content of P is set as small as possible. Since the excessive reduction of P pushes up a refining cost and becomes economically

disadvantageous, the content of P is desirably set to 0.002% or more.

[0022]

S: 0.005% or less

S deteriorates low-temperature toughness and ductility of a base material and hence, the content of S is desirably set small with an allowable upper limit of 0.005%.

[0023]

Cr: 0.40 to 1.5%

Cr is an important alloy element in the present invention, and has an effect of increasing hardenability of steel and also has an effect of suppressing the deterioration of toughness of the bond area of the multi pass weld due to low-temperature tempering. This is because the inclusion of Cr delays the diffusion of C in the steel plate and hence, when the steel plate is reheated to a temperature region where the low-temperature tempering embrittlement occurs, morphology change of carbide in martensite can be suppressed. It is necessary for the steel plate to contain 0.40% or more of Cr to acquire such an effect. On the other hand, when the content of Cr exceeds 1.5%, the effect is saturated so that not only does it become economically disadvantageous but also weldability is lowered. Accordingly, the content of Cr is limited to a value which falls within a range from 0.40 to 1.5%. The content of Cr is preferably limited to a value which falls

within a range from 0.40 to 1.2%.

[0024]

Mo: 0.05 to 1.0%

Mo is an element effective for remarkably increasing hardenability thus increasing hardness of a base material. Further, Mo has an effect of suppressing the deterioration of toughness of the bond area of the multi pass weld due to low-temperature tempering. The content of Mo is set to 0.05% or more for acquiring such an effect. However, when the content of Mo exceeds 1.0%, Mo adversely influences toughness, ductility and weld crack resistance of the base material and hence, the content of Mo is set to 1.0% or less. Accordingly, the content of Mo is limited to a value which falls within a range from 0.05 to 1.0%. The content of Mo is preferably limited to a value which falls within a range from 0.1 to 0.8%.

[0025]

Nb: 0.005 to 0.025%

Nb is an important element having both an effect of improving toughness of the multi pass weld and an effect of suppressing the occurrence of delayed fracture by making the microstructure of the base material and the multi pass weld finer by causing the precipitation of carbonitride and also by fixing solid solution N. It is necessary for the steel plate to contain 0.005% or more Nb to acquire such effects. On the other hand, when the content of Nb exceeds 0.025%, coarse

carbonitride precipitates and there may be a case where the coarse carbonitride becomes an initiation point of fracture. Accordingly, the content of Nb is limited to a value which falls within a range from 0.005 to 0.025%. The content of Nb is preferably limited to a value which falls within a range from 0.007 to 0.023%.

[0026]

Ti: 0.005 to 0.03%

Ti has an effect of suppressing grains in the bond area of the multi pass weld from becoming coarse by forming TiN due to fixing of solid solution N, and also has an effect of suppressing the deterioration of toughness and the occurrence of delayed fracture in the low-temperature tempering temperature region due to the decrease of solid solution N. It is necessary for the steel plate to contain 0.005% or more Ti to acquire such effects. On the other hand, when the content of Ti exceeds 0.03%, TiC precipitates so that toughness of the base material is deteriorated. Accordingly, the content of Ti is limited to a value which falls within a range from 0.005 to 0.03%. The content of Ti is preferably limited to a value which falls within a range from 0.007 to 0.025%.

[0027]

Al: 0.1% or less

Al acts as a deoxidizing agent and is most popularly used in a molten steel deoxidizing process of a steel plate. Further,

by forming AlN by fixing solid solution N in steel, Al has an effect of suppressing grains in the bond area of the multi pass weld from becoming coarse and an effect of suppressing the deterioration of toughness and the occurrence of delayed fracture in the low-temperature tempering temperature region due to the reduction of solid solution N. On the other hand, when the content of Al exceeds 0.1%, Al is mixed into weld metal at the time of welding thus deteriorating toughness of weld metal. Accordingly, the content of Al is limited to 0.1% or less. The content of Al is preferably limited to a value which falls within a range from 0.01 to 0.07%.

[0028]

N: 0.0015 to 0.0060%

N is bonded with Ti thus precipitating TiN, and has an effect of contributing to the enhancement of toughness by suppressing austenite particles from becoming coarse in HAZ. It is necessary for the steel plate to contain 0.0015% or more N to secure a required quantity of TiN having such an effect. On the other hand, when the content of N exceeds 0.0060%, in a region which is heated to a temperature at which TiN is melted at the time of welding, a quantity of solid solution N is increased so that the deterioration of toughness in the low-temperature tempering temperature region becomes conspicuous. Accordingly, the content of N is limited to a value which falls within a range from 0.0015 to 0.0060%. The

content of N is preferably limited to a value which falls within a range from 0.0020 to 0.0055%.

[0029]

B: 0.0003 to 0.0020%

B is an element effective for remarkably increasing hardenability with addition of a trace amount of B thus increasing hardness of a base material. Further, in a region which is heated to a temperature at which TiN is melted at the time of welding, solid solution N is fixed as BN so that B has an effect of suppressing the deterioration of toughness in the low-temperature tempering temperature region due to succeeding welding. The content of B may preferably be 0.0003% or more for acquiring such an effect. However, when the content of B exceeds 0.0020%, B adversely influences toughness, ductility and weld crack resistance of the base material. Accordingly, the content of B is set to 0.0020% or less. The content of B is preferably limited to a value which falls within a range from 0.0005 to 0.0018%. The balance of the steel plate is Fe and unavoidable impurities.

[0030]

According to the present invention, to further enhance properties of the steel plate, in addition to the above-mentioned basic component system, the steel plate may contain one, two or more kinds of components selected from a group consisting of W, Cu, Ni, V, REM, Ca and Mg.

[0031]

W: 0.05 to 1.0%

W is an element effective for remarkably increasing hardenability thus increasing hardness of a base material. The content of W may preferably be 0.05% or more for acquiring such an effect. However, when the content of W exceeds 1.0%, W adversely influences toughness, ductility and weld crack resistance of the base material. Accordingly, the content of W is set to 1.0% or less.

[0032]

All of Cu, Ni and V are elements which contribute to the enhancement of strength of steel, and the steel plate may contain proper amounts of Cu, Ni, V depending on strength which the steel plate requires.

[0033]

Cu: 1.5% or less

Cu is an element effective for increasing hardenability thus increasing hardness of the base material. The content of Cu may preferably be 0.1% or more for acquiring such an effect. However, when the content of Cu exceeds 1.5%, the effect is saturated and Cu causes hot brittleness thus deteriorating surface property of a steel plate. Accordingly, the content of Cu is set to 1.5% or less.

[0034]

Ni: 2.0% or less

Ni is an element effective for increasing hardenability thus increasing hardness of the base material. The content of Ni may preferably be 0.1% or more for acquiring such an effect. However, when the content of Ni exceeds 2.0%, the effect is saturated so that it becomes economically disadvantageous. Accordingly, the content of Ni is set to 2.0% or less.

[0035]

V: 0.1% or less

V is an element effective for increasing hardenability thus increasing hardness of the base material. The content of V may preferably be 0.01% or more for acquiring such an effect. However, when the content of V exceeds 0.1%, toughness and ductility of the base material is deteriorated. Accordingly, the content of V is set to 0.1% or less.

[0036]

All of REM, Ca and Mg contribute to the enhancement of toughness, and these elements are selectively added corresponding to properties which the steel plate desires. When REM is added, the content of REM may preferably be 0.002% or more. On the other hand, when the content of REM exceeds 0.008%, the effect is saturated. Accordingly, an upper limit of REM is set to 0.008%.

When Ca is added, the content of Ca may preferably be 0.0005% or more. On the other hand, when the content of Ca exceeds 0.005%, the effect is saturated. Accordingly, an

upper limit of Ca is set to 0.005%.

When Mg is added, the content of Mg may preferably be 0.001% or more. On the other hand, when the content of Mg exceeds 0.005%, the effect is saturated. Accordingly, an upper limit of Mg is set to 0.005%.

[0037]

$$DI^* = 33.85 \times (0.1 \times C)^{0.5} \times (0.7 \times Si + 1) \times (3.33 \times Mn + 1) \times (0.35 \times Cu + 1) \\ \times (0.36 \times Ni + 1) \times (2.16 \times Cr + 1) \times (3 \times Mo + 1) \times (1.75 \times V + 1) \times (1.5 \times W + 1) \\ \dots (1),$$

wherein the respective element symbols are contents (mass%) of the elements.

This parameter: DI* (hardenability index) is defined to form the base structure of the base material into martensite thus imparting excellent abrasion resistant property to the base structure within the range of the above-mentioned composition, and a value of the parameter is set to 45 or more. When the value of the parameter is set to less than 45, a quenching depth from a surface layer in the plate thickness direction becomes less than 10 mm and hence, a lifetime of the steel plate as the abrasion resistant steel plate is shortened.

When the value of the parameter exceeds 180, the base structure of the base material is martensite and hence, the base structure exhibits favorable abrasion resistant property. However, low-temperature crack property at the time of welding and low-temperature weld toughness are deteriorated.

Accordingly, the value of the parameter DI* is preferably set to 180 or less. The value of the parameter DI* is more preferably set to a value which falls within a range from 50 to 160.

[0038]

$C+Mn / 4-Cr / 3+10P \leq 0.47$ (2),

wherein the respective element symbols are contents (mass%) of the elements.

When the basic structure of the base material of the steel plate is formed of martensite and has the composition which exhibits excellent toughness in both the bond area and the low-temperature tempering embrittlement area when welding is performed, a value of the parameter: $C+Mn/4-Cr/3+10P$ is set to 0.47 or less within a range of the above-mentioned composition. Although the base structure of the base material is held in martensite and exhibits favorable abrasion resistant property even when the value of the parameter exceeds 0.47, weld toughness is remarkably deteriorated. The value of parameter may preferably be 0.45 or less.

[0039]

[Microstructure]

According to the present invention, to enhance abrasion resistant property, a base phase or of the microstructure of a steel plate is defined to martensite. The structure such as bainite or ferrite other than martensite lowers abrasion

resistant property and hence, it is preferable not to mix such structure into martensite as much as possible. However, when a total area ratio of these structures is less than 10%, the influence exerted by these structures can be ignored. Further, when surface hardness of the steel plate is less than 400 HBW10/3000 in Brinell hardness, a lifetime of the steel plate as abrasion resistant steel is shortened. Accordingly, it is desirable to set the surface hardness to 400 HBW10/3000 or more in Brinell hardness.

[0040]

In the developed steel according to the present invention, the microstructure of the bond area is the mixed structure of martensite and bainite. The structure such as ferrite other than martensite and bainite lowers abrasion resistant property and hence, it is preferable not to mix such structure as much as possible. However, when a total area ratio of these structures is less than 20%, the influence exerted by these structures can be ignored.

Further, in the developed steel according to the present invention, to secure toughness of the bond area, it is preferable that carbonitride particles of Nb and Ti having an average particle size of 1 μm or less are present at a rate of 1000 pieces/ mm^2 or more, an average particle size of prior austenite is less than 200 μm , and an average particle size of lower microstructure surrounded by a large tilt grain

boundary having a radial hook of 15° or more is less than 70 μm .

[0041]

The abrasion resistant steel according to the present invention can be manufactured under the following manufacturing conditions. In the explanation made hereinafter, the indication "°C" relating to temperature means temperature at 1/2 position of a plate thickness. It is preferable that a molten steel having the above-mentioned composition is produced by a known molten steel producing method, and the molten steel is formed into a raw steel material such as a slab having a predetermined size by a continuous casting process or an ingot-making/blooming method.

[0042]

Next, the obtained raw steel material is immediately subjected to hot rolling without cooling or is subjected to hot rolling following heating at a temperature of 950 to 1250°C after cooling thus forming a steel plate having a desired plate thickness. Immediately after hot rolling, water cooling is performed or quenching is performed after reheating. Thereafter, when necessary, tempering is performed at a temperature of 300°C or below.

[Embodiment 1]

[0043]

Steel slabs which were prepared with various

compositions shown in Table 1 by way of a steel converter, ladle refining and a continuous casting method were heated at a temperature of 1000 to 1250°C and, thereafter, the steel slabs were subjected to hot rolling under manufacturing conditions shown in Table 2. Water cooling (quenching (DQ)) was applied to some steel plates after rolling. With respect to other steel plates, air cooling was performed after rolling, and water cooling (quenching (RQ)) was performed after reheating.

On the obtained steel plates, the surface hardness measurement, the evaluation of abrasion resistant property, the base material toughness measurement, a T shape fillet weld cracking test (evaluation of delayed fracture resistant property), a synthetic heat-affected zone test and a toughness test of a weld of an actual weld joint were carried out in accordance with following manners. The acquired result is shown in Table 3.

[0044]

[Surface Hardness 1]

The surface hardness measurement was carried out on each steel plate in accordance with the stipulation of JIS Z 2243(1998) for measuring surface hardness below a surface layer (hardness of a surface measured after removing scales on the surface layer). In the measurement, tungsten hard balls having a diameter of 10 mm were used, and a load was set to 3000 kgf.

[0045]

[Base-material Toughness 1]

A V notch test specimen was sampled from each steel plate in the direction perpendicular to the rolling direction at a position away from a surface of the steel plate by 1/4 of a plate thickness in accordance with the stipulation of JIS Z 2202(1998), and a Charpy impact test was carried out at three respective temperatures with respect to each steel plate in accordance with the stipulation of JIS Z 2242(1998), absorbed energies at a test temperature of 0°C and -40°C were obtained, and base-material toughness is evaluated. The test temperature of 0°C was selected by taking the use of the steel plate in a warm area into consideration.

The steel plate where an average of three absorbed energies (also referred to as vE_0) at the test temperature of 0°C was 30 J or more was determined as the steel plate having excellent base-material toughness (within the scope of the present invention).

[0046]

[Abrasion Resistant Property 1]

With respect to abrasion resistant property, a rubber wheel abrasion test was carried out on each steel plate in accordance with the stipulation of ASTM G65. The test was carried out by using specimens each having a size of 10 mmt (t: plate thickness) × 75 mmw (w: width) × 20 mmL (L: length)

(t (plate thickness) \times 75 mmw \times 20 mmL when the plate thickness is less than 10 mm), and by using abrasive sand made of 100% SiO₂ as an abrasive material.

A weight of the specimen was measured before and after the test, and wear of the specimen was measured. The test result was evaluated based on an abrasion resistance rate: (wear of soft steel plate)/(wear of each steel plate) using the wear of soft steel plate (SS400) as the reference (1.0). This means that the larger the abrasion resistance rate, the more excellent the abrasion resistant property becomes, and with respect to the scope of the present invention, the steel plate which exhibited the abrasion resistance rate of 4.0 or more was determined excellent.

[0047]

[Delayed Fracture 1]

In a T shape fillet weld cracking test, restriction welding was carried out on specimens each of which was assembled in a T shape as shown in Fig. 1 by shielded metal arc welding and, thereafter, test welding was carried out at a room temperature (25°C \times humidity 60%) or after preheating to 100°C.

The welding method was shielded metal arc welding (welding material: LB52UL (4.0 mm Φ)), wherein a heat input was 17 kJ/cm, and welding of 3 layers and 6 passes was carried out. After the test, the specimen was left at a room temperature for 48 hours and, thereafter, 5 pieces of weld cross-sectional

observation samples (bead length 200 mm being equally divided by 5) were sampled from the test plate, and the presence or non-presence of occurrence of cracks in a welded heat affected zone was investigated by a projector and an optical microscope. In both the specimens prepared without preheating and the specimens prepared with preheating at a temperature of 100°C, in 5 respective sampled cross-sectional samples, the samples where the occurrence of cracks in the welded heat affected zone was not found at all were evaluated as being excellent in delayed fracture resistance.

[0048]

[Weld Toughness 1-1]

In a synthetic heat-affected zone test, the low-temperature tempering of the bond area when two pass CO₂ gas shielded arc welding with a welding heat input of 17 kJ/cm is performed was simulated. A heat cycle is applied to the bond area in such a manner that the bond area in first pass welding (initial pass) was held at a temperature of 1400°C for 1 second and was cooled at a cooling rate of 30°C/s from 800 to 200°C, and next, as the low-temperature tempering by second pass welding (succeeding welding), the bond area was held at a temperature of 300°C for 1 second and was cooled at a cooling rate of 5°C/s from 300 to 100°C.

A square bar test specimen sampled in the rolling direction was subjected to the above-mentioned heat cycle by

a high-frequency induction heating device and, thereafter, a V notch Charpy impact test was carried out in accordance with the stipulation of JIS Z 2242 (1998). The V notch Charpy impact test was carried out with respect to three specimens for each steel plate while setting a test temperature at 0°C.

The steel plate where an average value of three absorbed energies (vE_0) was 30 J or more was determined as the steel plate having excellent HAZ toughness (within the scope of the present invention).

With respect to the steel plates having a plate thickness of less than 10 mm, V notch Charpy specimens having a sub size (5 mm × 10 mm) were sampled and were subjected to a Charpy impact test. The steel plate where an average value of three absorbed energies (vE_0) was 15 J or more was determined as the steel plate having excellent HAZ toughness (within the scope of the present invention).

[0049]

[Weld Toughness 1-2]

Further, to confirm toughness of an actual weld joint, a multi-pass weld joint (V-shape groove) was prepared by shielded metal arc welding (heat input: 17 kJ/cm, preheating: 150°C, interpass temperature: 150°C, welding material: LB52UL (4.0 mm Φ)).

A Charpy impact specimen was sampled from the weld joint at a position 1 mm below a surface of the weld joint, and a

notch location was the V-shape groove and is set at a bond on a groove side perpendicular to the surface of the steel plate. A V notch Charpy impact test was carried out in accordance with the stipulation of JIS Z 2242 (1998) using the specimens sampled in this manner. Fig. 2 shows a sampling position of the Charpy impact specimen and the notch location.

The V notch Charpy impact test of the actual weld joint was carried out using three specimens while setting the test temperature at 0°C. The steel plate where an average value of three absorbed energies (vE_0) is 30 J or more was determined as the steel plate having excellent toughness at a multi pass weld (within the scope of the present invention).

With respect to the steel plates having a plate thickness of less than 10 mm, V notch Charpy specimens having a sub size (5 mm × 10 mm) were sampled and were subjected to a Charpy impact test. The steel plate where an average value of three absorbed energies (vE_0) was 15 J or more was determined as the steel plate having excellent bond area toughness (within the scope of the present invention).

Table 2 shows manufacturing conditions of steel plates used in the test, and Table 3 shows the results of the above-mentioned respective tests. The present invention examples (steels No. 1 to 5) had the surface hardness of 400 HBW10/3000 or more, exhibited excellent abrasion resistant property, and had base-material toughness of 30 J or more at

0°C. Further, no cracks occurred in the T shape fillet weld cracking test, and the present invention examples had excellent toughness also with respect to the synthetic heat-affected zone test and the actual weld joint toughness and hence, it was confirmed that the present invention examples exhibited excellent weld toughness.

On the other hand, with respect to comparison examples (steels No. 6 to 19) whose compositions were outside the scope of the present invention, it was confirmed that the comparison examples could not satisfy targeted performances with respect to any one or a plurality of properties and tests among surface hardness, abrasion resistant property, the T shape fillet weld cracking test, base-material toughness, the reproduced heat cycle Charpy impact test, the Charpy impact test of the actual weld joint.

[Embodiment 2]

[0050]

Steel slabs which were prepared with various compositions shown in Table 4 by way of a steel converter, ladle refining and a continuous casting method were heated at a temperature of 1000 to 1250°C and, thereafter, the steel slabs were subjected to hot rolling under manufacturing conditions shown in Table 5. Water cooling (quenching (DQ)) is applied to some steel plates immediately after rolling. With respect to other steel plates, air cooling was applied to other steel

plates after rolling, and water cooling (quenching (RQ)) was performed after reheating.

On the obtained steel plates, the surface hardness measurement, the evaluation of abrasion resistant property, the base material toughness measurement, a T shape fillet weld cracking test (evaluation of delayed fracture resistant property), a synthetic heat-affected zone test and a toughness test of a weld of an actual weld joint were carried out in accordance with following manners. The acquired result is shown in Table 6.

[0051]

[Surface Hardness 2]

The surface hardness measurement was carried out in accordance with the stipulation of JIS Z 2243(1998) thus measuring surface hardness below a surface layer (hardness of a surface measured after removing scales on the surface layer). In the measurement, tungsten hard balls having a diameter of 10 mm were used, and a load was set to 3000 kgf.

[0052]

[Base-material Toughness 2]

A V notch test specimen was sampled from each steel plate in the direction perpendicular to the rolling direction at a position away from a surface of the steel plate by 1/4 of a plate thickness in accordance with the stipulation of JIS Z 2202(1998), and a Charpy impact test was carried out at three

respective temperatures with respect to each steel plate in accordance with the stipulation of JIS Z 2242(1998), and absorbed energy at test temperatures of 0°C and -40°C were obtained, and base-material toughness was evaluated. The test temperature of 0°C was selected by taking the use of the steel plate in a warm region into consideration, and the test temperature of -40°C was selected by taking the use of the steel plate in a cold region into consideration.

The steel plate where an average value of three absorbed energies (also referred to as vE_0) at the test temperature of 0°C was 30 J or more and an average value of three absorbed energies (also referred to as vE_{-40}) at the test temperature of -40°C was 27 J or more was determined as the steel plate having excellent base-material toughness (within the scope of the present invention). With respect to the steel plates having a plate thickness of less than 10 mm, V notch Charpy specimens having a sub size (5 mm × 10 mm) were sampled and were subjected to a Charpy impact test. The steel plate where an average value of three absorbed energies (vE_0) was 15 J or more and an average value of three absorbed energies (vE_{-40}) was 13 J or more was determined as the steel plate having excellent base-material toughness (within the scope of the present invention).

[0053]

[Abrasion Resistant Property 2]

With respect to abrasion resistant property, a rubber wheel abrasion test was carried out in accordance with the stipulation of ASTM G65. The test was carried out by using a specimen having a size of 10 mm t (t: plate thickness) × 75 mm w (w: width) × 20 mm L (L: length) (t (plate thickness) × 75 mm w × 20 mm L when the plate thickness was less than 10 mm t), and by using abrasive sand made of 100% SiO₂ as an abrasive material.

A weight of the specimen was measured before and after the test and wear of the specimen was measured. The test result was evaluated based on an abrasion resistance rate: (wear of soft steel plate) / (wear of each steel plate) using wear of soft steel plate (SS400) as the reference (1.0). This means that the larger the abrasion resistance rate, the more excellent the abrasion resistant property becomes, and with respect to the scope of the present invention, the steel plate which exhibits the abrasion resistance rate of 4.0 or more was determined excellent.

[0054]

[Delayed Fracture 2]

In a T shape fillet weld cracking test, restriction welding was carried out on a specimen which was assembled in a T shape as shown in Fig. 1 by shielded metal arc welding and, thereafter, test welding was carried out at a room temperature (25°C × humidity 60%) or after preheating to 100°C.

The welding method was shielded metal arc welding (welding material: LB52UL (4.0 mm Φ)), wherein a welding heat input was 17 kJ/cm, and welding of 3 layers and 6 passes was carried out. After the test, the specimen was left at a room temperature for 48 hours and, thereafter, 5 pieces of weld cross-sectional observation samples (bead length 200 mm being equally divided by 5) were sampled from a test plate, and the presence or non-presence of occurrence of cracks in a welded heat affected zone was investigated by a projector and an optical microscope. In both the specimens prepared without preheating and the specimens prepared with preheating at a temperature of 100°C, among 5 respective sampled cross-sectional samples, the samples where the occurrence of cracks in the welded heat affected zone was not found at all were evaluated as being excellent in delayed fracture resistance.

[0055]

[Weld Toughness 2-1]

In a synthetic heat-affected zone test, the low-temperature tempering of the bond area of the welded heat affected zone when two layer CO₂ gas shielded arc welding with a welding heat input of 17 kJ/cm is performed was simulated. A heat cycle is applied to the bond area in such a manner that the bond portion in first pass welding (initial pass) was held at a temperature of 1400°C for 1 second and was cooled at a

cooling rate of 30°C/s from 800 to 200°C, and next, as the low-temperature tempering by second pass welding (succeeding welding), the bond area was held at a temperature of 300°C for 1 second and was cooled at a cooling rate of 5°C/s from 300 to 100°C.

A square bar test specimen sampled in the rolling direction was subjected to the above-mentioned heat cycle by a high-frequency induction heating device and, thereafter, a V notch Charpy impact test was carried out in accordance with the stipulation of JIS Z 2242(1998). The Charpy impact test was carried out with respect to three specimens for each steel plate while setting test temperatures at 0°C and -40°C at respective temperatures.

The steel plate where an average value of three absorbed energies (vE_0) was 30 J or more and an average value of three absorbed energies (vE_{-40}) was 27 J or more was determined as the steel plate having excellent HAZ toughness (within the scope of the present invention).

With respect to the steel plates having a plate thickness of less than 10 mm, V notch Charpy specimens having a sub size (5 mm × 10 mm) were sampled and were subjected to a Charpy impact test. The steel plate where an average value of three absorbed energies (vE_0) was 15 J or more and an average value of three absorbed energies (vE_{-40}) was 13 J or more was determined as the steel plate having excellent HAZ toughness (within the

scope of the present invention).

[0056]

[Weld Toughness 2-2]

Further, to confirm toughness of an actual weld joint, a multi-pass weld joint (V-shape groove) was prepared by shielded metal arc welding (heat input: 17 kJ/cm, preheating: 150°C, interpass temperature: 150°C, welding material: LB52UL (4.0 mm Φ)).

A Charpy impact specimen was sampled from the weld joint at a position 1 mm below a surface of the weld joint, and a notch location was the V-shape groove and is set at a bond on a groove side perpendicular to the surface of the steel plate. A V notch Charpy impact test was carried out in accordance with the stipulation of JIS Z 2242 (1998) using the specimens sampled in this manner. Fig. 2 shows a sampling position of the Charpy impact specimen and the notch location.

The V notch Charpy impact test of the actual weld joint was carried out using three specimens for each test temperature while setting the test temperature at 0°C and -40°C. The steel plate where an average value of three absorbed energies (vE_0) is 30 J or more and an average value of three absorbed energies (vE_{-40}) is 27 J or more was determined as the steel plate having excellent multi pass weld toughness (within the scope of the present invention).

With respect to the steel plates having a plate thickness

of less than 10 mm, V notch Charpy specimens having a sub size (5 mm × 10 mm) were sampled and were subjected to a Charpy impact test. The steel plate where an average value of three absorbed energies (vE_0) was 15 J or more and an average value of three absorbed energies (vE_{-40}) was 13 J or more was determined as the steel plate having excellent multi pass weld toughness (within the scope of the present invention).

[0057]

Table 5 shows manufacturing conditions of steel plates used in the test, and Table 6 shows the results of the above-mentioned respective tests. The present invention examples (steels No. 20 to 22 (steel No. 22 having a plate thickness of 8 mm)) had the surface hardness of 400 HBW10/3000 or more, exhibited excellent abrasion resistant property, and had base-material toughness of 30 J or more at 0°C and base-material toughness of 27 J or more at -40°C. Further, no cracks occurred in the T shape fillet weld cracking test, and the present invention examples also had excellent toughness with respect to the synthetic heat-affected zone test and the actual weld joint and hence, it was confirmed that the present invention examples exhibited excellent multi pass weld toughness.

[0058]

On the other hand, it was confirmed that although the steel No.23 where the composition falls within the scope of

the present invention but DI^* exceeds 180 exhibited favorable results in surface hardness, abrasion resistant property and base-material toughness, the results of a T shape fillet weld cracking test, a synthetic heat-affected zone test and an actual weld joint toughness were close to lower limit values of targeted performances and hence, the steel No.23 was inferior to other present invention examples. With respect to the composition of the steel No.24, the content of Si falls outside the scope of the present invention. Accordingly, although steel No.24 exhibited favorable results in surface hardness, abrasion resistant property and base-material toughness, steel No.24 could not satisfy targeted performances in a T shape fillet weld cracking test, a synthetic heat-affected zone test and an actual weld joint toughness.

[0059]

Although the composition of the steel No. 25 fell within the scope of the present invention, the value of a parameter $C+Mn/4-Cr/3+10P$ on a left side of the formula (2) exceeded 0.47. Accordingly, the result of the synthetic heat-affected zone test and the actual weld joint toughness were close to lower limits of the targeted performances and hence, steel No. 25 was inferior to other present invention examples. In the description of Tables 4, 5 and 6, although the steel No. 23 falls within the scope of the present invention called for in claim 3 in composition, the value of DI^* falls outside the scope

of the present invention called for in claim 6 and hence, the steel No. 23 is set as the comparison example. Although the steel No. 25 falls within the scope of the present invention called for in claim 1 in composition, the steel No. 25 does not satisfy the formula (2) and falls outside the scope of the present invention called for in claim 7 and hence, the steel No. 25 is set as the comparison example.

[0060]

Table 1

No.	Composition																DI*	Formula (2)	Remarks			
	C	Si	Mn	P	S	Al	Cr	Mo	Nb	Ti	W	Cu	Ni	V	N	B				REM	Ca	Mg
1	0.241	0.29	0.75	0.007	0.0014	0.031	0.48	0.11	0.016	0.014					34	8				59.9	0.34	Present invention example
2	0.215	0.12	0.46	0.008	0.0012	0.023	0.67	0.35	0.023	0.025	0.08				56	5		21		76.5	0.19	Present invention example
3	0.279	0.10	0.62	0.004	0.0010	0.037	1.01	0.09	0.021	0.009	0.13	0.15	0.12		24	17			16	98.3	0.14	Present invention example
4	0.221	0.47	1.05	0.009	0.0015	0.047	0.52	0.18	0.007	0.018				0.04	44	10	53			105.2	0.40	Present invention example
5	0.251	0.16	0.41	0.005	0.0009	0.026	0.43	0.42	0.013	0.011	0.12			0.05	54	9				78.9	0.26	Present invention example
6	<u>0.178</u>	0.25	0.94	0.007	0.0019	0.031	0.59	0.18	0.020	0.019					45	10		18		76.8	0.29	Comparison example
7	<u>0.329</u>	0.38	0.53	0.006	0.0012	0.026	0.47	0.21	0.018	0.015		0.22	0.20		27	15				81.5	0.36	Comparison example
8	0.260	0.15	<u>1.47</u>	0.005	0.0010	0.039	0.44	0.08	0.012	0.012				0.04	38	8	50			92.0	<u>0.53</u>	Comparison example
9	0.273	0.29	0.84	<u>0.015</u>	0.0021	0.025	0.53	0.17	0.020	0.015	0.07				40	10		27		95.1	0.46	Comparison example
10	0.217	0.45	0.79	0.008	0.0012	0.028	<u>0.18</u>	0.31	0.018	0.008				0.05	23	12				69.4	0.43	Comparison example
11	0.238	0.27	0.65	0.006	0.0009	0.044	0.95	<u>0.03</u>	0.021	0.020			0.32	56	9				22	72.9	0.14	Comparison example
12	0.254	0.38	0.57	0.007	0.0011	0.031	0.71	0.28	<u>0.001</u>	0.015				0.04	40	10				98.7	0.23	Comparison example
13	0.228	0.24	0.64	0.008	0.0012	0.037	1.01	0.11	<u>0.039</u>	0.021			0.41		57	16				90.8	0.13	Comparison example
14	0.264	0.15	0.59	0.006	0.0010	0.030	0.77	0.34	0.021	<u>0.001</u>				0.04	37	9	39			103.7	0.21	Comparison example
15	0.271	0.23	1.04	0.008	0.0009	0.027	0.43	0.22	0.011	<u>0.033</u>					31	8				92.5	<u>0.47</u>	Comparison example
16	0.229	0.17	0.61	0.004	0.0010	0.033	0.82	0.30	0.018	0.017				<u>11</u>	12					91.5	0.15	Comparison example
17	0.245	0.23	0.80	0.007	0.0011	0.025	0.63	0.12	0.012	0.015	0.10			0.03	<u>68</u>	11		20		87.6	0.31	Comparison example
18	0.230	0.38	0.96	0.005	0.0019	0.047	0.55	0.21	0.009	0.021					31	<u>1</u>				97.3	0.34	Comparison example
19	0.286	0.12	0.45	0.009	0.0012	0.045	0.47	0.10	0.017	0.011				53	8		19			<u>40.6</u>	0.33	Comparison example

Note 1: Underlined values being outside the scope of the present invention

Note 2: Contents of N, B, REM, Ca, Mg indicated by ppm in chemical components

Note 3: $DI^* = 33.85 \times (0.1 \times C)^{0.5} \times (0.7 \times Si + 1) \times (3.33 \times Mn + 1) \times (0.35 \times Cu + 1) \times (0.36 \times Ni + 1) \times (2.16 \times Cr + 1) \times (3 \times Mo + 1) \times (1.75 \times V + 1) \times (1.5 \times W + 1)$

Note 4: Formula (2) = $C + Mn/4 - Cr/3 - Mo/6 + 10P$

Respective element symbols being contents (mass%)

[0061]

Table 2

Steel No.	Raw material thickness (mm)	Plate thickness (mm)	Hot rolling		Cooling method		Heat treatment		Remarks
			Heating temperature (°C)	Hot rolling finish temperature (°C)	Cooling method	Heating temperature (°C)	Cooling method		
1	200	12	1150	890	air cooling	900	water cooling	Present invention example	
2	200	25	1080	900	air cooling	930	water cooling	Present invention example	
3	200	32	1150	910	air cooling	900	water cooling	Present invention example	
4	200	25	1200	880	water cooling	no heat treatment		Present invention example	
5	200	16	1100	900	water cooling	200	air cooling	Present invention example	
<u>6</u>	200	25	1150	900	air cooling	900	water cooling	Comparison example	
<u>7</u>	200	20	1150	890	water cooling	no heat treatment		Comparison example	
<u>8</u>	250	32	1200	930	air cooling	910	water cooling	Comparison example	
<u>9</u>	200	25	1100	900	air cooling	900	water cooling	Comparison example	
<u>10</u>	300	20	1150	920	water cooling	no heat treatment		Comparison example	
<u>11</u>	250	16	1150	880	air cooling	900	water cooling	Comparison example	
<u>12</u>	300	32	1050	870	air cooling	900	water cooling	Comparison example	
<u>13</u>	200	16	1200	900	water cooling	no heat treatment		Comparison example	
<u>14</u>	250	25	1150	860	air cooling	930	water cooling	Comparison example	
<u>15</u>	250	25	1150	890	air cooling	900	water cooling	Comparison example	
<u>16</u>	300	30	1050	870	air cooling	930	water cooling	Comparison example	
<u>17</u>	250	20	1150	900	water cooling	no heat treatment		Comparison example	
<u>18</u>	300	32	1100	900	air cooling	900	water cooling	Comparison example	
<u>19</u>	250	25	1150	900	air cooling	900	water cooling	Comparison example	

Note 1: Underlined values being outside the scope of the present invention

[0062]

Table 3

Steel No.	Surface hardness	Abrasion resistant property Abrasion resistance rate	T shape fillet weld cracking test		Base material toughness vE0 (J)	Synthetic heat-affected zone test		Shielded metal arc welding Toughness of multi pass weld vE0(J)	Remarks
	HBW 10/3000		No preheating (Presence or non-presence of cracks)	Preheating to 100°C (Presence or non-presence of cracks)		Corresponding to multi pass weld (bonding + low-temperature tempering) vE0(J)			
1	462	4.8	no cracks	no cracks	77		57	92	Present invention example
2	410	4.3	no cracks	no cracks	102		71	121	Present invention example
3	526	5.5	no cracks	no cracks	44		38	60	Present invention example
4	428	4.2	no cracks	no cracks	90		71	112	Present invention example
5	470	4.9	no cracks	no cracks	60		44	73	Present invention example
6	<u>342</u>	<u>3.6</u>	no cracks	no cracks	153		112	159	Comparison example
7	609	6.5	<u>cracks occurred</u>	<u>cracks occurred</u>	<u>18</u>		<u>5</u>	<u>22</u>	Comparison example
8	493	5.2	<u>cracks occurred</u>	<u>cracks occurred</u>	44		<u>16</u>	34	Comparison example
9	531	5.5	<u>cracks occurred</u>	<u>cracks occurred</u>	35		<u>13</u>	<u>29</u>	Comparison example
10	427	4.3	no cracks	no cracks	70		<u>19</u>	39	Comparison example
11	441	4.6	no cracks	no cracks	59		<u>17</u>	35	Comparison example
12	457	4.9	<u>cracks occurred</u>	<u>cracks occurred</u>	<u>23</u>		<u>15</u>	31	Comparison example
13	448	4.5	no cracks	no cracks	<u>27</u>		<u>13</u>	<u>27</u>	Comparison example
14	505	5.3	no cracks	no cracks	<u>18</u>		<u>8</u>	<u>18</u>	Comparison example
15	506	5.3	<u>cracks occurred</u>	<u>cracks occurred</u>	<u>10</u>		<u>5</u>	<u>15</u>	Comparison example
16	433	4.6	no cracks	no cracks	40		<u>14</u>	<u>29</u>	Comparison example
17	469	4.9	<u>cracks occurred</u>	<u>cracks occurred</u>	<u>11</u>		<u>6</u>	<u>20</u>	Comparison example
18	451	4.7	<u>cracks occurred</u>	<u>cracks occurred</u>	<u>50</u>		<u>19</u>	35	Comparison example
19	<u>372</u>	<u>3.7</u>	no cracks	no cracks	47		33	61	Comparison example

Note 1: Underlined values being outside the scope of the present invention

[0063]

Table 4

No.	Composition																DI*	Formula (2)	Remarks			
	(mass%)																					
	C	Si	Mn	P	S	Al	Cr	Mo	Nb	Ti	W	Cu	Ni	V	N	B	REM	Ca	Mg			
20	0.214	0.35	0.59	0.007	0.0018	0.031	1.05	0.17	0.019	0.014				0.04	41	10				96.5	0.05	Present invention example
21	0.227	0.12	0.70	0.005	0.0015	0.020	0.96	0.48	0.023	0.017		0.25	0.24	0.04	30	12				174.6	0.05	Present invention example
22	0.251	0.22	0.62	0.006	0.0011	0.035	0.68	0.15	0.017	0.012					29	7				67.9	0.21	Present invention example
23	0.265	0.39	1.02	0.009	0.0021	0.022	0.71	0.21	0.015	0.011		0.52	0.42	0.05	27	11				<u>188.5</u>	0.34	Comparison example
24	0.282	<u>0.01</u>	0.89	0.008	0.0025	0.035	0.49	0.14	0.024	0.018	0.12				37	14	40			78.3	0.40	Comparison example
25	0.278	0.35	1.12	0.009	0.0021	0.031	0.45	0.12	0.020	0.015					40	10				89.1	<u>0.48</u>	Comparison example

Note 1: Underlined values being outside the scope of the present invention

Note 2: Contents of N, B, REM, Ca, Mg indicated by mass ppm in chemical components

Note 3: DI* = $33.85 \times (0.1 \times C)^{0.5} \times (0.7 \times Si + 1) \times (3.33 \times Mn + 1) \times (0.35 \times Cu + 1) \times (0.36 \times Ni + 1) \times (2.16 \times Cr + 1) \times (3 \times Mo + 1) \times (1.75 \times V + 1) \times (1.5 \times W + 1)$ Note 4: P in formula (2): $C + Mn/4 - Cr/3 - Mo/6 + 10P$ Respective element symbols being contents (mass%)

[0064]

Table 5

Steel No.	Raw material thickness (mm)	Plate thickness (mm)	Hot rolling			Heat treatment		Remarks
			Heating temperature (°C)	Hot rolling finish temperature (°C)	Cooling method	Heating temperature (°C)	Cooling method	
20	300	45	1150	900	air cooling	900	water cooling	Present invention example
21	300	60	1100	880	air cooling	870	water cooling	Present invention example
22	200	8	1150	820	air cooling	900	water cooling	Present invention example
<u>23</u>	250	32	1100	870	air cooling	900	water cooling	Comparison example
<u>24</u>	250	25	1100	900	water cooling	no heat treatment		comparison example
<u>25</u>	300	40	1150	900	air cooling	900	water cooling	comparison example

Note 1: Underlined values being outside the scope of the present invention

[0065]

Table 6

Steel No.	Surface hardness HBW 10/3000	Abrasion resistant property Abrasion resistance rate	Base material toughness		T shape fillet weld cracking test		Synthetic heat-affected zone test Corresponding to multi pass weld (bonding + low-temperature tempering) vE0(J) vE-40(J)	Shielded metal arc welding Toughness of multi pass weld vE0(J) vE-40(J)		Remarks	
			vE0 (J)	vE-40 (J)	No preheating	Preheating to 100°C presence or non-presence of cracks		vE0(J)	vE-40(J)		
20	412	4.3	96	74	no cracks	no cracks	69	40	110	72	Present invention example
21	436	4.5	71	50	no cracks	no cracks	59	40	83	50	Present invention example
22	473	5.0	40	32	no cracks	no cracks	35	28	50	31	Present invention example
23	499	5.3	32	32	no cracks	no cracks	30	27	40	27	Comparison example
24	530	5.5	32	30	<u>cracks occurred</u>	<u>cracks occurred</u>	<u>20</u>	<u>8</u>	50	<u>15</u>	Comparison example
25	524	5.4	33	32	no cracks	no cracks	31	27	46	27	Comparison example

Note 1: Underlined values being outside the scope of the present invention

Claims

1. An abrasion resistant steel plate having excellent weld toughness and excellent delayed fracture resistance, and having a composition containing by mass% 0.20 to 0.30% C, 0.05 to 1.0% Si, 0.40 to 1.2% Mn, 0.010% or less P, 0.005% or less S, 0.40 to 1.5% Cr, 0.05 to 1.0% Mo, 0.005 to 0.025% Nb, 0.005 to 0.03% Ti, 0.1% or less Al, 0.0015 to 0.0060% N, 0.0003 to 0.0020% B, and Fe and unavoidable impurities as a balance, wherein hardenability index DI^* expressed by a formula (1) is 45 or more, and a base phase of the microstructure is formed of martensite.

$$DI^* = 33.85 \times (0.1 \times C)^{0.5} \times (0.7 \times Si + 1) \times (3.33 \times Mn + 1) \times (0.35 \times Cu + 1) \times (0.36 \times Ni + 1) \times (2.16 \times Cr + 1) \times (3 \times Mo + 1) \times (1.75 \times V + 1) \times (1.5 \times W + 1) \dots (1),$$

wherein the respective element symbols are contents (mass%) of the elements.

2. The abrasion resistant steel plate having excellent weld toughness and excellent delayed fracture resistance according to claim 1, wherein the steel composition further contains by mass% 0.05 to 1.0% W.

3. The abrasion resistant steel plate having excellent weld toughness and excellent delayed fracture resistance according to claim 1 or 2, wherein the steel composition further contains by mass% one or two or more kinds of components

selected from a group consisting of 1.5% or less Cu, 2.0% or less Ni, and 0.1% or less V.

4. The abrasion resistant steel plate having excellent weld toughness and excellent delayed fracture resistance according to any one of claims 1 to 3, wherein the steel composition further contains by mass% one, two or more kinds of components selected from a group consisting of 0.08% or less REM, 0.005% or less Ca, and 0.005% or less Mg.

5. The abrasion resistant steel plate having excellent weld toughness and excellent delayed fracture resistance according to any one of claims 1 to 4, wherein surface hardness of the steel plate is 400 HBW10/3000 or more in Brinell hardness.

6. The abrasion resistant steel plate having excellent weld toughness and excellent delayed fracture resistance according to any one of claims 1 to 5, wherein hardenability index DI* is 180 or less.

7. The abrasion resistant steel plate having excellent weld toughness and excellent delayed fracture resistance according to any one of claims 1 to 6, wherein the steel plate satisfies a following formula (2).

$$C+Mn / 4-Cr / 3+10P \leq 0.47 \dots (2),$$

wherein the respective element symbols are contents (mass%) of the elements.

Fig.1

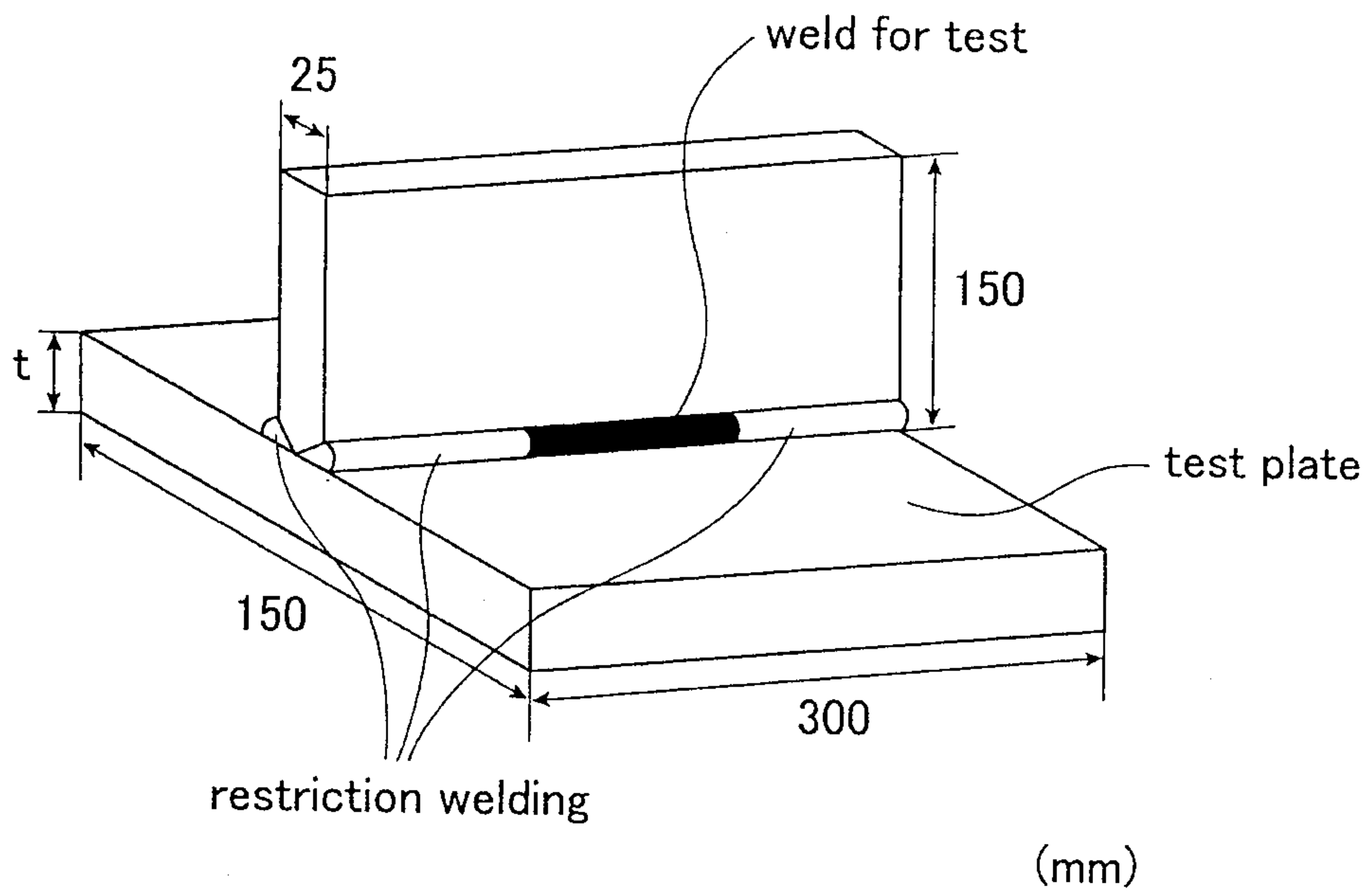

Fig.2

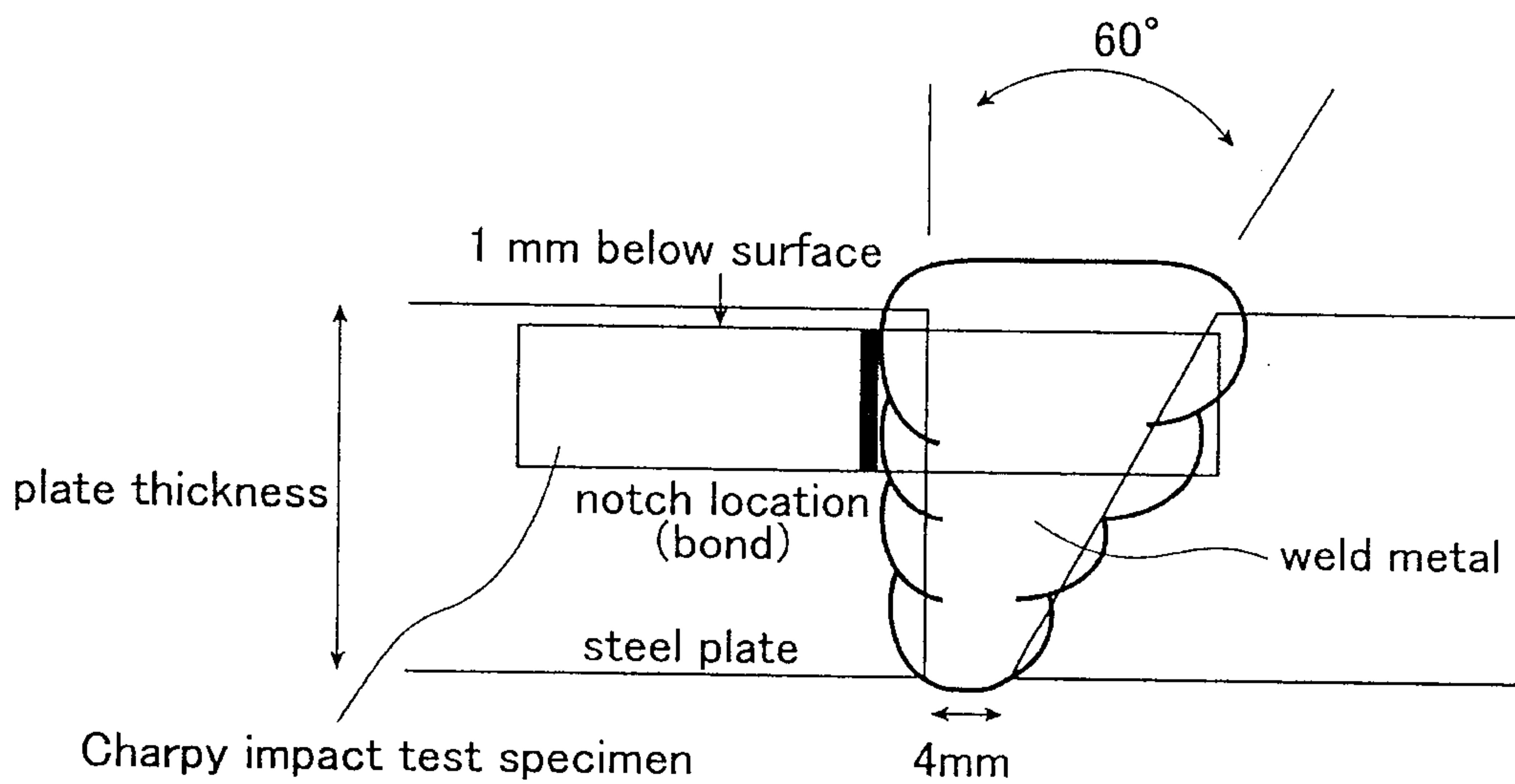

Fig.1

