

Oct. 7, 1930.

H. BREGMAN

1,777,427

TOY TELEPHONE

Filed March 6, 1924

2 Sheets-Sheet 1

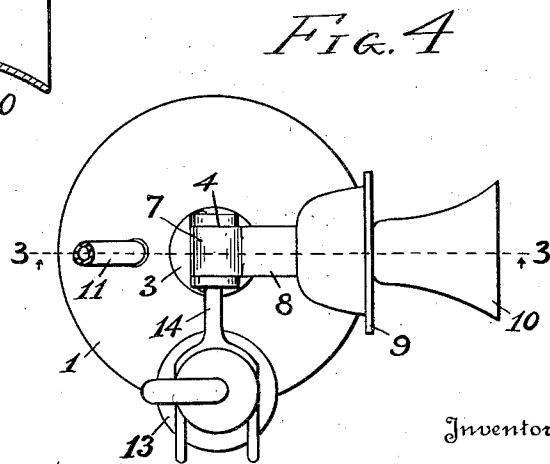
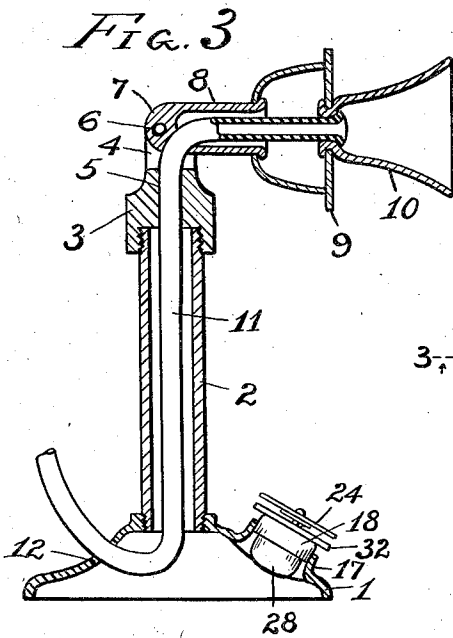
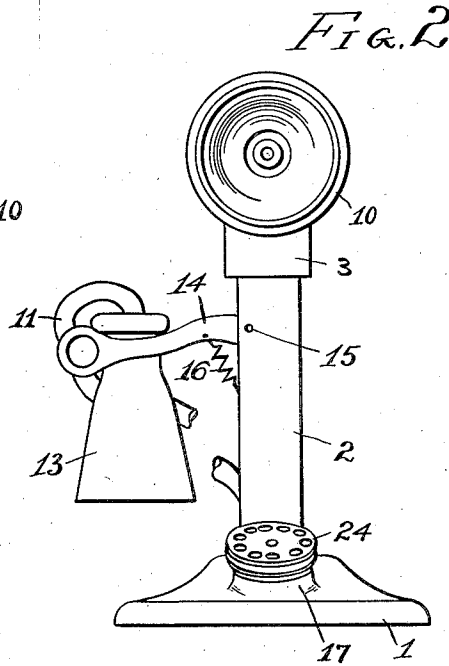
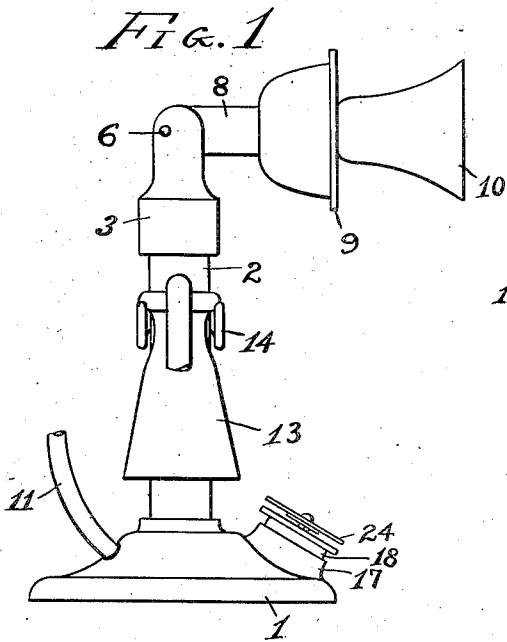

Inventor

H. Bregman

By *W. E. Dunstan*
his Attorney

Oct. 7, 1930.

H. BREGMAN

1,777,427

TOY TELEPHONE

Filed March 6, 1924

2 Sheets-Sheet 2

FIG. 5

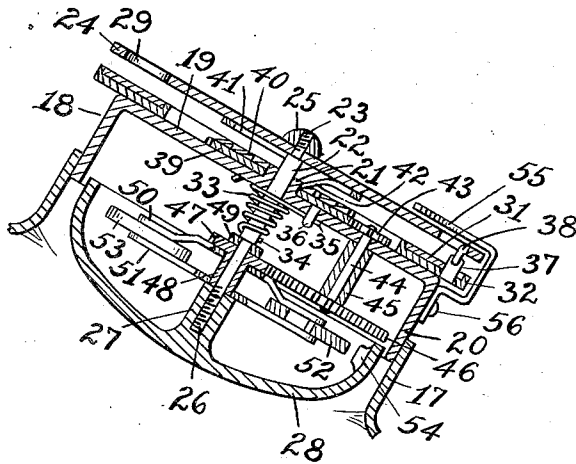

FIG. 6

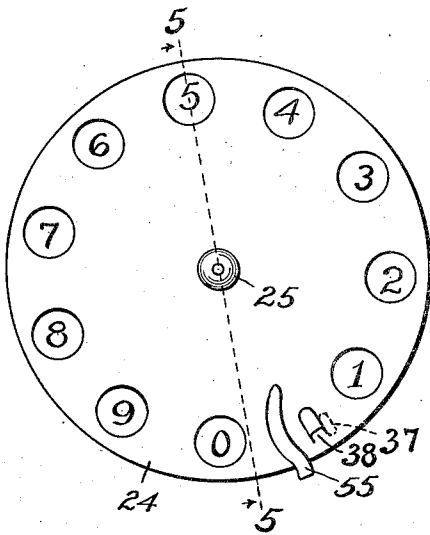

FIG. 7

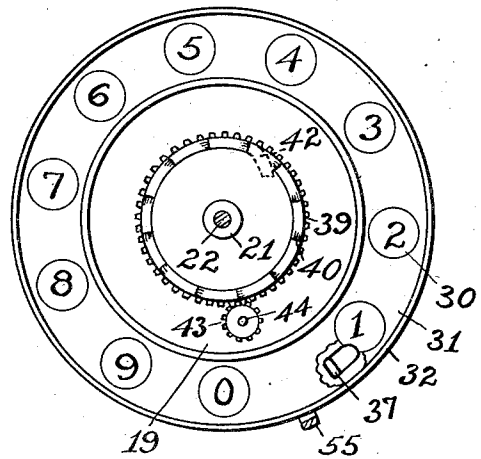

FIG. 8

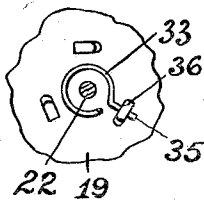
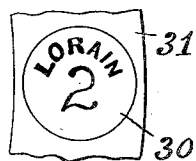

FIG. 9



Inventor

H. Bregman

By *W. H. Dunstan,*

his Attorney

UNITED STATES PATENT OFFICE

HARRY BREGMAN, OF LORAIN, OHIO, ASSIGNOR TO THE STEEL STAMPING COMPANY,
OF LORAIN, OHIO, A CORPORATION OF OHIO

TOY TELEPHONE

Application filed March 6, 1924. Serial No. 697,276.

This invention relates to toy telephones, and has for its principal object to provide a toy telephone of simple and inexpensive construction by means of which a child may amuse himself by talking into the telephone and hearing his own voice from out thereof, or may talk to another child.

Another object of the invention is to provide a toy telephone, which is provided with a rotatably mounted dial adapted to be turned to different numbers designating a supposed call and then automatically return to its original position to cause the ringing of a bell.

In order that the invention may be clearly understood, the same will be hereinafter fully described with reference to the accompanying drawings, and the novel features thereof will be particularly pointed out in the appended claims.

In the drawings, similar characters of reference are used to designate corresponding parts.

Figure 1 is a side elevation of a toy telephone constructed in accordance with my invention,

Fig. 2 is a front view thereof,

Fig. 3 is a vertical sectional view taken on line 3—3 of Fig. 4,

Fig. 4 is a plan view of Fig. 1,

Fig. 5 is a sectional view, on an enlarged scale, of the dial and bell-ringing mechanism, taken on line 5—5 of Fig. 6,

Fig. 6 is a plan view of Fig. 5,

Fig. 7 is a similar view to Fig. 5, the dial having been removed,

Fig. 8 is a fragmental view illustrating the means for holding one end of the coiled spring to the top of the cap,

Fig. 9 illustrates a fragmental portion of the ring under the dial having thereon a numeral and the name of a city.

Referring to the drawings, 1 represents a hollow base into which is fixed a tubular upright 2 having at its upper end a neck 3 bifurcated at 4 and provided with a central opening 5. Pivotaly connected between the bifurcated end 4 at 6 is a tongue 7 of a tubular member 8, to the outer end of which is fixed a semi-spherical hollow body 9, and

to its forward flat side is fixed a mouth-piece 10. Connected to and leading from the inner end of said mouth-piece is a rubber tube 11, which passes through the tubular member 8, down through the neck 3 and upright 2, into the hollow base 1 and out of an opening 12 thereof. Said rubber tube may be of any desired length and its free end leads into and is connected to a receiver 13. Said receiver is adapted to hang upon a laterally extending hook 14, which is pivoted at 15 to the tubular upright 2. A spring 16 tends to throw the hook in its upward position unless the receiver is hung thereupon.

Stamped from the hollow base 1 is an upright flange 17 in the form of a ring for the purpose of receiving and supporting a dial mechanism, which is carried by a cap 18 comprising a top 19 and a downwardly turned rim 20 secured to the inside of said flange. At the center of the top 19 of said cap is an upstanding boss 21, and rotatably mounted therein is a shaft 22, to the upper reduced end 23 of which is fixed a dial 24 by means of a nut 25, and to the lower threaded end 26 is fixed the inwardly extending central boss 27 of an inverted bell 28. The dial 24 is provided with a plurality of suitable openings near its periphery, as indicated by 29 for receiving a child's finger for rotating the dial clockwise, and below said openings are arranged consecutive numerals and the names of cities as at 30, which are printed on a ring 31 of sheet material resting in a circular channel member 32 fixed to the top 19 of the cap 18.

The rotation of the dial 24 clockwise is adapted to wind up a suitable coiled spring 33, which is fixed at its lower end 34 to the shaft-22 while its upper end 35 is held by a downwardly bent lug 36 stamped from the top 19 of the cap 18. Several lugs as 36 are provided and the end of the coiled spring is adapted to be held by the one for giving the proper tension thereto. Upon withdrawing the finger from the opening 29 and thereby releasing the dial 24, said dial will be returned to its original position by the action of the coiled spring 33. A stop 37 projecting upwardly from the channel member 32 is adapt-

55

60

65

70

75

80

85

90

95

100

ed to be engaged by a nib 38 turned downwardly from the dial 24 to limit the rotation of said dial. In order that the return movement of the dial 24 will cause the ringing of the bell 28, but the bell will not be rung when the dial is being rotated clockwise, a gear wheel 39 is rotatably mounted upon the boss 21, and is provided with ratchet-teeth 40 upon the upper face thereof. A suitable flat spring 41 is fixed to the underside of the dial 24, and its depending end 42 is adapted to pass over the ratchet-teeth 40 when the dial is rotated clockwise, but engage said ratchet-teeth and thereby cause the gear-wheel 39 to be rotated counter clockwise when the dial is being returned to its original position by the action of the coiled spring 33. The gear-wheel 39 is in mesh with a pinion 43 fixed to a spindle 44, which is rotatably mounted in the top 19 of the cap 18 and passes through an elongated sleeve 45. A toothed-wheel 46 is fixed to the lower end of the spindle 44, and this toothed-wheel meshes with a toothed-pinion 47 formed integrally with a sleeve 48, which is loosely mounted upon the shaft 22 between the boss 27 of the bell 28 and a collar 49 fixed to said shaft. Fixed to the sleeve 48 are a pair of spaced cross-arms 50 and 51, between the outer ends of which are arranged slotted hammers 52 and 53, which are adapted to fly outwardly due to the centrifugal force and strike a protuberance 54 of the bell 28. A finger stop 55 is supported by the cap 18 at 56, and the higher the numbers at 30 used, the greater distance will the dial 24 travel, the more the coiled spring 33 will be wound up, and the longer the bell will ring.

From the foregoing description and drawings, it is readily seen that a child may talk through the mouth-piece 10, and the sound will be carried by the rubber tube 11 to the receiver 13 and may be heard by the same or another child, that the rotating of the dial 24 by the insertion of the finger in any one of the openings 29 will wind up the coiled spring 33 in proportion to the travel of the dial, and said coiled spring will cause the dial to return to its original position, and in so doing will rotate the gear-wheel 39, the pinion 43 and toothed-wheel 46, which will drive the toothed-pinion 47 and thus cause the swift rotation of the cross-arms 50 and 51, thereby causing the hammers 52 and 53 to fly outwardly and by striking the protuberance 54 ring the bell 28 for a length of time corresponding to the winding up of said coiled spring.

It will be understood that minor details in the construction may be changed so long as the same was within the scope of the claims.

Having fully described my invention, what I claim is:

1. In a toy telephone, the combination of a base, an upright supported by the base, a

mouth-piece supported by the upright, a receiver, means connecting the mouth-piece to the receiver, a dial rotatably supported by the base, a bell, and means whereby the rotating of the dial in one direction will not cause the ringing of the bell and the rotation thereof in the opposite direction will cause the ringing of the bell, substantially as described.

2. In a toy telephone, the combination of a base, an upright supported by the base, a mouth-piece supported by the upright, a receiver, means connecting the mouth-piece to the receiver, a dial rotatably supported by the base, a bell, means adapted to strike the bell, means for causing said means not to strike the bell when the dial is rotating in one direction and to cause said means to strike said bell when rotating in the opposite direction, substantially as described.

3. In a toy telephone, the combination of a base, an upright supported by the base, a mouth-piece supported by the upright, a receiver, means connecting the mouth-piece to the receiver, a shaft rotatably supported by the base, a dial fixed to the shaft, a bell, means rotatably mounted on the shaft for ringing the bell, and means whereby the dial may be rotated in one direction without rotating the means for ringing the bell and will rotate the means for ringing the bell when rotating in the opposite direction, substantially as described.

4. In a toy telephone, the combination of a base, an upright supported by the base, a mouth-piece supported by the upright, a receiver, means connecting the mouth-piece to the receiver, a shaft rotatably supported by the base, a dial fixed to the shaft, a bell fixed to the shaft, means rotatably mounted on the shaft adapted to strike the bell, and means whereby the rotation of the dial in one direction will not rotate the means adapted to strike the bell and will rotate the said means to cause it to strike the bell when rotated in the opposite direction, substantially as described.

5. In a toy telephone, the combination of a base, an upright supported by the base, a mouth-piece supported by the upright, a receiver, means connecting the mouth-piece to the receiver, a shaft rotatably supported by the base, a dial fixed to the shaft, a bell, arms rotatably mounted upon the shaft, hammers carried by the arms adapted to move outwardly by rotation of the arms for striking the bell, and means whereby the rotation of the dial in one direction will not rotate said arms and will rotate said arms when rotated in the opposite direction, substantially as described.

6. In a toy telephone, the combination of a base, an upright supported by the base, a mouth-piece supported by the upright, a receiver, means connecting the mouth-piece to the receiver, a shaft rotatably supported by

the base, a dial fixed to the shaft for manually rotating it in one direction, a coiled spring adapted to be wound up when the shaft is rotated in said direction and to rotate the shaft in the opposite direction when the dial is released, a bell, means rotatably mounted upon the shaft adapted to strike the bell, and means whereby the rotating of the shaft by the dial will not rotate the means adapted to strike the bell and will rotate said means to cause it to strike the bell when the shaft is rotated by said spring, substantially as described.

7. In a toy telephone, the combination of a base, an upright supported by the base, a mouth-piece supported by the upright, a receiver, means connecting the mouth-piece to the receiver, a shaft rotatably supported by the base, a dial fixed to the shaft for manually rotating it in one direction, a coiled spring adapted to be wound up when the shaft is rotated in said direction and to rotate the shaft in the opposite direction when the dial is released, means for limiting the movement of the dial, a bell fixed to the shaft, arms rotatably mounted upon the shaft, hammers carried by the arms adapted to move outwardly by the rotation of the arms for striking the bell, and means whereby the rotation of the shaft by the dial will not rotate the arms and will rotate said arms when the shaft is rotated by said spring to cause said hammers to strike said bell, substantially as described.

8. In a toy telephone, the combination of a base, an upright supported by the base, a mouth-piece supported by the upright, a receiver, means connecting the mouth-piece to the receiver, a shaft rotatably supported by the base, a dial fixed to the shaft, a dial having finger openings for rotating the dial, numerals arranged opposite said finger openings, means for limiting the movement of the dial, a stop for the finger when rotating the dial in one direction, means for returning the dial to its original position upon withdrawing the finger, a bell, means rotatably mounted upon the shaft for ringing the bell, and means whereby the rotation of the dial by the finger will not rotate the means for ringing the bell and will rotate said means when the dial is returning to its original position, substantially as described.

9. In a toy telephone, the combination of a base, an upright supported by the base, a mouth-piece supported by the upright, a receiver, means connecting the mouth-piece to the receiver, a shaft rotatably supported by the base, a dial fixed to the shaft, a dial having finger openings for rotating the dial, numerals arranged opposite said finger openings, means for limiting the movement of the dial, a stop for the finger when rotating the dial in one direction, a coiled spring adapted to be wound up when the dial is ro-

tated by the finger, the coiled spring being adapted to rotate the dial and shaft in the opposite direction, a bell, means rotatably mounted upon the shaft for ringing the bell, and means whereby the rotation of the dial by the finger will not rotate the means for ringing the bell and will rotate the said means when the dial is returning to its original position, substantially as described.

10. In a toy telephone, the combination of a base, an upright supported by the base, a mouth-piece supported by the upright, a receiver, means connecting the mouth-piece to the receiver, a shaft rotatably supported by the base, a dial fixed to the shaft, a dial having finger openings for rotating the dial, numerals arranged opposite said finger openings, means for limiting the movement of the dial, a stop for the finger when rotating the dial in one direction, a coiled spring having one end fixed to said shaft and its free end to said base, a bell, means rotatably mounted upon the shaft for ringing the bell, and means whereby the rotation of the dial by the finger will not rotate said means for ringing the bell and will wind up said coiled spring and the unwinding of said coiled spring will rotate said means for ringing the bell, substantially as described.

11. In a toy telephone, the combination of a base, an upright supported by the base, a mouth-piece supported by the upright, a receiver, means connecting the mouth-piece to the receiver, a shaft rotatably supported by the base, a dial fixed to the shaft, a dial having finger openings for rotating the dial, numerals arranged opposite said finger openings, means for limiting the movement of the dial, a stop for the finger when rotating the dial in one direction, a coiled spring having one end fixed to said shaft and its free end to said base, a bell, means rotatably mounted upon the shaft for ringing the bell, a rotatably mounted gear-wheel, means for driving said means for ringing the bell over the gear-wheel, and means for not causing rotation of said gear-wheel when the dial is rotated in one direction and for causing rotation thereof when the dial is released, substantially as described.

12. In a toy telephone, the combination of a base, an upright supported by the base, a mouth-piece supported by the upright, a receiver, means connecting the mouth-piece to the receiver, a shaft rotatably supported by the base, a dial fixed to the shaft, a dial having finger openings for rotating the dial, numerals arranged opposite said finger openings, means for limiting the movement of the dial, a stop for the finger when rotating the dial in one direction, a coiled spring having one end fixed to said shaft and its free end to said base, a bell, a gear-wheel rotatably mounted upon the base, a sleeve rotatably mounted upon said shaft, arms fixed to said

sleeve, hammers carried by the arms adapted to move outwardly by the rotation of the arms for striking the bell, a toothed-pinion formed integrally with said sleeve, means for driving the toothed-pinion over said gear-wheel, said gear-wheel being provided with ratchet-teeth, and a spring carried by said dial adapted to pass over the ratchet-teeth in one direction and engage said ratchet teeth in the other direction for causing rotation of said gear-wheel, substantially as described.

13. In a toy telephone, the combination of a base, an upright supported by the base, a mouth-piece supported by the upright, a receiver, means connecting the receiver to the base, a dial rotatably supported by the base, a bell, and means whereby the rotation of the dial in one direction will not cause the ringing of the bell and the rotation thereof in the other direction will cause the ringing of the bell, substantially as described.

14. In a toy telephone, the combination of a hollow base, an upright supported by the base, a mouth-piece supported by the upright, a receiver, means connecting the receiver to the base, a dial rotatably supported by the base, a bell within the base, and means whereby the rotation of the dial in one direction will not cause the ringing of the bell and the rotation thereof in the opposite direction will cause the ringing of the bell, substantially as described.

15. A toy telephone including a transmitter and receiver supporting base and an automatic calling device dial rotatably supported by the base, and a gong and striker mechanism supported by the base, and mechanical means for actuating the striker mechanism also supported by the base and mechanically connected with and responsive to rotation of the dial.

16. A toy telephone of the "dial type", having a rotatable dial, a signalling device co-operatively arranged with reference to the dial, and connections intermediate the dial and signalling device for sounding the latter upon partial movements of rotation of the dial.

17. In a toy telephone having a base, standard, transmitter and receiver, a number selecting dial mounted upon the base, a gong mounted within the base, a shaft supporting the dial for manual rotation, a ratchet and pawl permitting free movement of the dial in one direction, a spring connected with the shaft and tensioned by the manual movement of the dial and operating to return the dial to normal position when left free, a striker for the gong and a gear train connectable with the shaft and actuating the striker upon return movement of the dial.

18. In a toy telephone, a base, and a calling device including a ring of indicia asso-

ciated with said base, a rotatable member mounted over said indicia, a signalling device, and means responsive to rotation of said member for actuating said signalling device.

19. In a toy telephone, a calling device including a ring of indicia, and a rotatable member having a finger engageable portion adapted to sweep over said indicia, a signalling device, and means responsive to rotation of said member for actuating said signalling device.

20. A toy telephone of the "dial type" having a rotatable member, a signalling device cooperatively arranged with reference to said rotatable member, and connections intermediate the rotatable member and signalling device for sounding the latter upon movement of said rotatable member.

21. A toy telephone of the "dial type" having a ring of indicia, a rotatable member above said indicia, a signalling device cooperatively arranged with reference to said rotatable member, and connections intermediate the rotatable member and signalling device for sounding the latter upon movement of said rotatable member.

22. In a toy telephone, a base, a post extending upwardly from said base and adapted to support a receiver and transmitter assembly, said base having a ring of spaced indicia associated therewith, a dial above said ring having apertures adapted to register with said indicia, a shaft projecting through the centers of said ring and dial, said shaft being mounted for rotation, a signal device supported within said base, and means responsive to rotation of said shaft for actuating said signal device.

23. In a toy telephone, a hollow base, a post extending upwardly from said base and adapted to support a receiver and transmitter assembly, a disc rigid with said base and having indicia thereon spaced in a ring about the center thereof, a dial pivotally mounted at the center of said disc and having apertures registering with said indicia, a signalling device mounted on the underside of said base, and means associated with said dial and signalling device and cooperating therewith through said base for actuating said signalling device in response to movement of said dial on the pivot thereof.

In testimony whereof I affix my signature.

HARRY BREGMAN.