

**(12) STANDARD PATENT**  
**(19) AUSTRALIAN PATENT OFFICE**

(11) Application No. **AU 2006251341 B2**

(54) Title  
**Femoral neck prosthesis**

(51) International Patent Classification(s)  
**A61F 2/36** (2006.01)

(21) Application No: **2006251341** (22) Date of Filing: **2006.05.24**

(87) WIPO No: **WO06/125633**

(30) Priority Data

(31) Number	(32) Date	(33) Country
<b>05011259.8</b>	<b>2005.05.24</b>	<b>EP</b>

(43) Publication Date: **2006.11.30**

(44) Accepted Journal Date: **2012.02.16**

(71) Applicant(s)  
**Zimmer GmbH; Guido Grappiolo**

(72) Inventor(s)  
**Grappiolo, Guido; Willi, Roland**

(74) Agent / Attorney  
**Griffith Hack, Level 19 109 St Georges Terrace, Perth, WA, 6000**

(56) Related Art  
**WO 2000/009044**  
**US 2003/050704**  
**US 6284002**  
**US 5580352**  
**US 2003/163202**  
**EP 1120096**

(12) NACH DEM VERTRAG ÜBER DIE INTERNATIONALE ZUSAMMENARBEIT AUF DEM GEBIET DES PATENTWESENS (PCT) VERÖFFENTLICHTE INTERNATIONALE ANMELDUNG

(19) Weltorganisation für geistiges Eigentum  
Internationales Büro



(43) Internationales Veröffentlichungsdatum  
30. November 2006 (30.11.2006)

PCT

(10) Internationale Veröffentlichungsnummer  
**WO 2006/125633 A1**

(51) Internationale Patentklassifikation:  
A61F 2/36 (2006.01)

(21) Internationales Aktenzeichen: PCT/EP2006/004976

(22) Internationales Anmeldedatum:  
24. Mai 2006 (24.05.2006)

(25) Einreichungssprache: Deutsch

(26) Veröffentlichungssprache: Deutsch

(30) Angaben zur Priorität:  
05011259.8 24. Mai 2005 (24.05.2005) EP

(71) Anmelder (für alle Bestimmungsstaaten mit Ausnahme von US): ZIMMER GMBH [CH/CH]; Sulzer Allee 8, CH-8404 Winterthur (CH).

(72) Erfinder; und

(75) Erfinder/Anmelder (nur für US): GRAPPIOLO, Guido [IT/IT]; Via delle Mimose 6, I-17024 Finale Ligure (IT). WILLI, Roland [CH/CH]; Auenrainstrasse 7, CH-8413 Neftenbach (CH).

(74) Anwalt: MANITZ, FINSTERWALD & PARTNER GBR; Posfach 31 02 20, 80102 München (DE).

(81) Bestimmungsstaaten (soweit nicht anders angegeben, für jede verfügbare nationale Schutzrechtsart): AE, AG, AL, AM, AT, AU, AZ, BA, BB, BG, BR, BW, BY, BZ, CA, CH, CN, CO, CR, CU, CZ, DE, DK, DM, DZ, EC, EE, EG, ES, FI, GB, GD, GE, GH, GM, HR, HU, ID, IL, IN, IS, JP, KE, KG, KM, KN, KP, KR, KZ, LC, LK, LR, LS, LT, LU, LV, LY, MA, MD, MG, MK, MN, MW, MX, MZ, NA, NG, NI, NO, NZ, OM, PG, PH, PL, PT, RO, RU, SC, SD, SE, SG,

[Fortsetzung auf der nächsten Seite]

(54) Title: FEMORAL NECK PROSTHESIS

(54) Bezeichnung: SCHENKELHALSPROTHESE

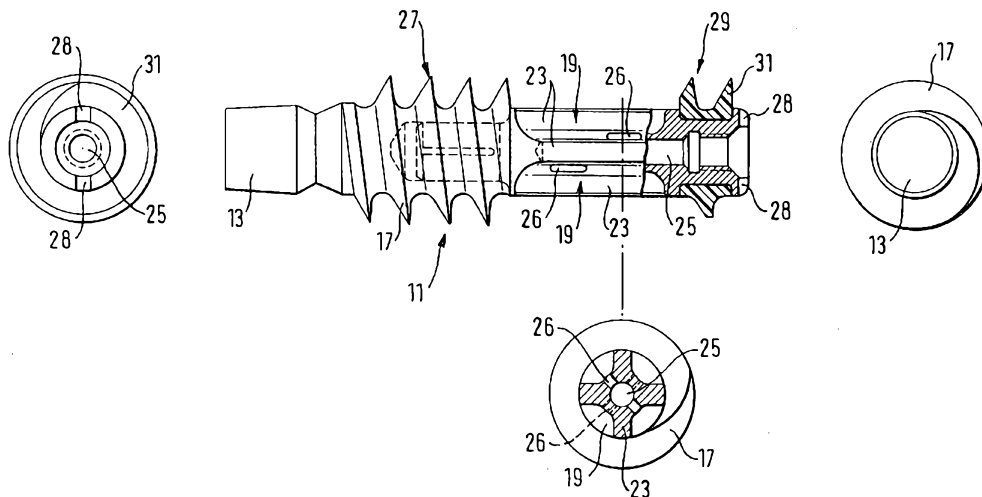

(57) Abstract: The invention relates to a shaft for a femoral neck prosthesis, which comprises an anchoring area (27, 29) which is arranged inside the femur in order to anchor the prosthesis into bone, a head area which is axially adjacent to the anchoring area (27, 29) on the proximal side, said head area comprising a device (13) which is connected to the prosthesis head (15), in addition to a distal end which is arranged opposite the head area in the axial direction of the anchoring area (27, 29). The invention is characterised in that the maximum cross-sectional dimension of the head area is at the most equal and, in particular, smaller than the maximum diameter of the anchoring area (27, 29), in such a manner that the maximum cross-sectional dimension of the shaft (11) is in the anchoring area (27, 29).

(57) Zusammenfassung: Die Erfindung betrifft einen Schaft für eine Schenkelhalssprothese, umfassend einen zur Anordnung im Inneren des Femurs vorgesehenen Verankerungsbereich (27, 29) zur Verankerung der Prothese im Knochen, einen sich axial an einer proximalen Seite an den Verankerungsbereich (27, 29) anschließenden Kopfbereich, der eine Vorrichtung (13) zum Verbinden mit einem Prothesenkopf (15) aufweist, sowie ein distales Ende, welches in axialer Richtung des Verankerungsbereichs (27, 29) dem Kopfbereich gegenüberliegt, wobei die maximale Querschnittsabmessung des Kopfbereichs höchstens gleich groß ist wie und insbesondere kleiner ist als ein maximaler Durchmesser des Verankerungsbereichs (27, 29), derart, dass die maximale Querschnittsdimension des Schaftes (11) im Verankerungsbereich (27, 29) vorliegt.



WO 2006/125633 A1



SK, SL, SM, SY, TJ, TM, TN, TR, TT, TZ, UA, UG, US,  
UZ, VC, VN, YU, ZA, ZM, ZW.

NL, PL, PT, RO, SE, SI, SK, TR), OAPI (BF, BJ, CF, CG,  
CI, CM, GA, GN, GQ, GW, ML, MR, NE, SN, TD, TG).

**(84) Bestimmungsstaaten** (soweit nicht anders angegeben, für jede verfügbare regionale Schutzrechtsart): ARIPO (BW, GH, GM, KE, LS, MW, MZ, NA, SD, SL, SZ, TZ, UG, ZM, ZW), eurasisches (AM, AZ, BY, KG, KZ, MD, RU, TJ, TM), europäisches (AT, BE, BG, CH, CY, CZ, DE, DK, EE, ES, FI, FR, GB, GR, HU, IE, IS, IT, LT, LU, LV, MC,

**Veröffentlicht:**

— mit internationalem Recherchenbericht

Zur Erklärung der Zweibuchstaben-Codes und der anderen Abkürzungen wird auf die Erklärungen ("Guidance Notes on Codes and Abbreviations") am Anfang jeder regulären Ausgabe der PCT-Gazette verwiesen.

## Femoral neck prosthesis

5 The invention relates to a femoral neck prosthesis comprising an anchorage region provided for arrangement in the interior of the femur for the anchorage of the prosthesis in the bone, a head region which adjoins the anchorage region axially at a proximal side and has a device for connection to a prosthesis head, and a distal end which is disposed opposite the head region in the axial direction of the anchorage region.

10 Hip joint prostheses are generally known for example from WO 00/09044 A1, in which the prosthesis shaft does not extend into the femur shaft (corpus femoris) as with shaft-fixed prostheses, but rather extends through the neck of the femur (collum femoris) without anchorage in the femur shaft. Prostheses of this type are also known  
15 as femoral neck prostheses.

A shaft of the initially named kind should be set forth which may be anchored to the femur in as simple and as secure a manner as possible.

20 The present invention provides in a first aspect a shaft for a femoral neck prosthesis, comprising an anchorage region provided for arrangement in the interior of the femur for the anchorage of the prosthesis in the bone, a head region which adjoins the anchorage region axially at a proximal side and has a device for connection to a  
25 prosthesis head, and a distal end which is disposed opposite the head region in the axial direction of the anchorage region;

wherein the maximum cross-sectional dimension of the head region is at most the same size as, and preferably smaller than, a maximum diameter of the anchorage region such that the maximum  
30 cross-sectional dimension of the shaft is present in the anchorage region;

wherein the anchorage region includes an external thread section with a spongiosa thread;

35 wherein the external thread section is arranged adjacent to the head region; and

wherein the shaft is arranged such that the shaft can be inserted through a passage formed in the femur from a lateral side of the femur

and can be secured within that passage by means of the anchorage region.

5 Provision is made with the shaft set forth here for the maximum cross-sectional dimension of the head region to be at most the same size as, and in particular smaller than, a maximum diameter of the anchorage region such that the maximum cross-sectional dimension of the shaft is present in the anchorage region. The anchorage of the shaft can take place inside a passage formed in the femur due to the anchorage region.  
10 In contrast to known thrust plate prostheses in which the prosthesis is supported axially at the resection surface via a plate-like element, with the implant set forth here, the fixing takes place within a bore extending substantially in the axis of the neck through the femur. It in particular proves to be favourable that, since no region is present at  
15 proximal whose cross-sectional dimension is larger than in the anchorage section, the insertion of the prosthesis can take place by minimally invasive techniques and in particular from lateral. When the anchorage region has an external thread section, the thread flanks can be provided with a height which is sufficient for a secure hold and  
20 simultaneously ensures a non-critical strain on the cortex.

The anchorage region of the shaft may include a cementing section and an external thread section with a spongiosa thread. This embodiment represents a hybrid solution, with the thread substantially serving for  
25 the reception of axial forces and the cementing section substantially serving for the support of torques. The thread is bearing in the femoral neck region where the cortex or the relatively compact spongiosa are located. A rather low tissue density and tissue strength is present in the transition region between the trochanter and the femoral neck. The  
30 prosthesis is supported in this region, with the bone cement stabilizing the spongiosa having a relatively low density. The introduction of the bone cement can take place by pressing in. The cementing section may, for example, have at least one recess for the reception of bone cement at its outer periphery.

35

The cementing section may furthermore have a geometry which is cross-shaped or star-shaped in cross-section in at least one axial

region, with substantially axially extending recesses being formed. Such a cross configuration or star configuration is also suitable for the use of instruments for screwing in or manipulating from lateral. The recesses may extend up to the distal end of the cementing section.

5 Provision may also be made for the cementing section to have at least one spirally or annularly circumferential groove as a recess for the reception of bone cement.

10 The recess may be accessible from the distal end of the shaft. This facilitates the handling from lateral on implanting.

The shaft has means in an exemplary embodiment which ensure a fluid communication for the supply of bone cement from the distal end of the shaft to the recess, which likewise facilitates the handling.

15

The external thread section may be arranged adjacent to the head region. It thus comes to lie in a region in which the thread comes to lie in spongiosa with a comparatively high density and finds a hold in the cortex at best with the thread tips.

20

The spongiosa thread, for example, has a substantially constant core diameter and/or a substantially constant external diameter. The maximum diameter of the external thread defines the maximum diameter of the shaft in an embodiment of the described implant. The thread height amounts in this context to at least 3mm, and in particular at least 4.5 mm, in specific embodiments.

25

Provision may furthermore be made for the maximum cross-sectional dimension of the head region to exceed the maximum core diameter of the thread by a maximum of 1/3 of the difference between the maximum external diameter and the maximum core diameter of the thread, and is in particular at most the same size as the maximum core diameter of the thread. This makes it possible that the shaft can be inserted from lateral via an opening provided for the reception of the anchorage region.

35

If the shaft has a cementing section, it may, for example, adjoin the

threaded section at distal and thus permit a support in the spongiosa which has good cement support.

5 The maximum cross-sectional dimension of the cementing section exceeds the maximum core diameter of the thread in an embodiment by at most  $1/3$  of the difference between the maximum external diameter and the maximum core diameter of the thread and is in particular at most the same size as the maximum core diameter of the thread. Provision may furthermore be made for the maximum cross-sectional  
10 dimension of the cementing section to be at least as large as the maximum cross-sectional dimension of the head region. These optional features ensure a good fit of the cementing section in the bore established for the insertion of the implant.

15 The cementing section may be provided with a sealing section in the region of its distal end, with the sealing section being made in thread form for example. If the anchorage region includes an external thread section with a spongiosa thread, the thread-shaped sealing section may correspond to the spongiosa thread, in particular with respect to the  
20 dimension of the external diameter and/or of the thread height.

The head section and the anchorage section are arranged coaxially, for example. A coaxial arrangement may likewise be present between at least two of the regions or sections head region, cementing section and  
25 external thread section.

The proximal to distal extent of the anchorage region may be dimensioned such that the distal end of the shaft comes to lie in the spongiosa tissue of the femur. The shaft then does not project laterally  
30 out of the femur.

The head region, for example, may have a conical or truncated conical connection element for connection to a prosthesis head.

35 An instrument set is also set forth here with which the shaft may be anchored to the femur in a simple and secure manner and the femoral neck prosthesis including the shaft can thus likewise be inserted in a

simple and secure manner. The instrument set includes a trepanning drill and a thread cutter for the manufacture of a passage as well as a screwing instrument to screw the shaft into the passage from lateral. An introduction instrument may additionally be provided for the  
5 introduction of bone cement which has an introduction section which may be mounted onto the distal end of the shaft. The introduction section may be made in the manner of a grommet and serves in particular as an adapter for the optimum adaption of the outflow end of a conventional cement syringe or cement gun to the distal end of the  
10 prosthesis shaft. The introduction section may be calibrated to the distal end of the shaft such that, in the mounted state, a channel formed in the shaft is sealed with respect to the environment. The introduction section may in particular be made in cap-shape, hood-shape or bell-shape at least regionally. The introduction section may be  
15 a separate component which may be connected to a cement syringe or cement gun.

The instrument set may be used in a method for the insertion of a femoral neck prosthesis of the kind described above in which the  
20 femoral head is removed via a front access and a corresponding incision, a core hole extending from lateral through the neck of the femur is formed, a thread is cut into the core hole, the prosthesis shaft is screwed into the passage formed in this manner and the prostheses head is mounted onto the shaft via the front access.

25 The shaft may be cemented in for example, provided a cementing section is provided. The bone cement is in particular introduced with a shaft already located in the passage. An in particular grommet-like introduction section of an introduction instrument may be mounted on  
30 to the distal end of the shaft for the cementing in thereof.

The machining of the acetabulum (hip ball-and-socket joint) of the hip bone for the insertion of the prosthesis shell in particular takes place via the front access (anterior) via which the femoral head is previously  
35 removed. Alternatively, it is also possible to carry out this machining via the previously formed core holder or the finished passage. In this process, a sleeve may be pushed into the core hole or into the finished

passage through which subsequently spindles for the necessary machining instruments may be guided and the actual instruments may be plugged onto the spindles pushed through. This sleeve may be utilized for the fixing of the femur in that the femur is fixed via an outwardly projecting section of the sleeve in a position correctly aligned relative to the hip bone, in particular on the operating table. The prosthesis shell may in particular be inserted via the front access via which the femoral head is removed, with this being able to take place after the forming of the core hole and before the cutting of the thread.

An anchorage of the prosthesis shaft by means of a thread formed in the passage makes it possible that a proximal-to-distal positional correct may be carried out by rotation of the shaft in the passage, with this being able to take place after the mounting of the prosthesis head.

All indications of alignment, positioning, orientation and direction which are used as required both in the claims and in the description as well as the drawings in connection with the prosthesis and in accordance with the technically usual conventions and which in particular relate to anatomical axes, planes, directions in space and directions of movement are familiar to the person skilled in the art and relate to the implanted state of the prosthesis.

The present invention provides in a second aspect a shaft for a femoral neck prosthesis, comprising an anchorage region provided for arrangement in the interior of the femur for the anchorage of the prosthesis in the bone, a head region which adjoins the anchorage region axially at a proximal side and has a device for connection to a prosthesis head, and a distal end which is disposed opposite the head region in the axial direction of the anchorage region,

wherein the maximum cross-sectional dimension of the head region is at most the same size as, and preferably smaller than, a maximum diameter of the anchorage region such that the maximum cross-sectional dimension of the shaft is present in the anchorage region,

wherein the anchorage region includes a cementing section,  
wherein the anchorage region includes an external thread section

with a spongiosa thread, wherein the external thread section is arranged adjacent to the head region,

wherein the cementing section adjoins the threaded section at distal; and

5 wherein the shaft is arranged such that the shaft can be inserted through a passage formed in the femur from a lateral side of the femur and can be secured within that passage by means of the anchorage region.

10 The invention will be described in the following by way of example with reference to the drawings. There are shown:

Fig. 1a different views of a prosthesis shaft of a hip joint prosthesis in accordance with a first embodiment;

- Fig. 1b views in accordance with Fig. 1a of a prosthesis shaft in accordance with a second embodiment;
- Fig. 2 a thread cutter of a set of instruments;
- 5 Fig. 3 the screwing in of the prosthesis shaft of the first embodiment with a screwing instrument;
- Fig. 4 the introduction of bone cement with a prosthesis shaft of the first embodiment with an introduction instrument;
- 10 Fig. 5 a prosthesis shaft of the first embodiment in the inserted state with a mounted prosthesis head;
- 15 Fig. 6 different views of a prosthesis shaft of a hip joint prosthesis in accordance with a third embodiment;
- Fig. 7 the screwing in of the prosthesis shaft of the third embodiment with another screwing instrument;
- 20 Fig. 8 the introduction of bone cement with a prosthesis shaft of the third embodiment with another introduction instrument; and
- 25 Fig. 9 a prosthesis shaft of the third embodiment in the inserted state with mounted prosthesis head.

Only the prosthesis shaft 11 of the hip joint prosthesis in accordance with the first embodiment is shown in Fig. 1a. The shaft 11 is made in multiple parts and includes a distal cementing section 29 and a proximal section, which is also called a head section and which is made at the proximal end  
5 as a cone 13 as well as a section 27 adjoining the cone 13 toward distal and provided with an external thread 17 made as a spongiosa thread. The cone 13 serves for the coupling to a prosthesis head not shown here and having a correspondingly shaped mount for the cone 13. The prosthesis furthermore includes a joint shell, likewise not shown, for the insertion  
10 into the hip bone. The two shaft parts 27, 29 described are firmly plugged together to form the shaft 11. For this purpose, the cementing section 29 is provided with a connection spigot 33 for which a corresponding spigot mount 35 is formed in the threaded section 27. The cementing section 29 has a star-shaped cross-section which is formed by four webs 23 standing  
15 at right angles to one another in respective pairs, extending in the axial direction and bounding recesses 19 for the reception of bone cement in the peripheral direction which are elongated in axial direction and open to distal.

20 Fig. 1b shows a second embodiment which differs from the first embodiment (Fig. 1a) by the configuration of the spongiosa thread 17. The arrangement of the thread flanks in the second embodiment is reversed relative to the first embodiment with respect to the axial direction.

25 Fig. 2 shows how a thread is cut on the femur into a previously formed core hole 51 by means of a thread cutter 41 in extension of the axis of the neck of the femur coming from lateral. The femoral head is only shown by

dashed lines since it has already been removed in this phase of the surgical procedure which will be looked at in more detail in the following.

5 In accordance with Fig. 3, the set of instruments furthermore includes a screwing instrument 43 which is calibrated to the distal cementing section 29 of the prosthesis shaft 11. The screwing instrument 43 is provided with fingers 49 which engage into the recesses 19 of the cementing section 29. The screwing instrument 43 is formed in this respect in a complementary manner to the cementing section 29 of the shaft 11.

10

In accordance with Fig. 4, an introduction instrument 45 of the set of instruments, which includes an introduction section 47 matched to the shape of the rear end of the cementing section 29, serves for the cementing in of the prosthesis shaft 11. The introduction section 47 is provided as a separate component which can be mounted on a conventional cement syringe or cement gun and thus serves as a type of adapter grommet. The discharge region of the introduction section 47 is made as a bell-shaped contact region 48 which projects radially beyond the cementing section 29 having only the core hole diameter and supports a radial widened section of the injected bone cement by its shape and prevents a discharge of bone cement from the passage 21. The injected bone cement enters via the introduction section 48 into the recesses 19 of the cementing section 29 and from there in substantially a radial direction into the material of the spongiosa of the femur bone with open pores.

25

In the completed state in accordance with Fig. 5, the prosthesis shaft 11 provided with the prosthesis head 15 mounted on the cone 13 is located in the correct depth inside the passage 21 and is anchored in the relatively

hard region of the neck of the femur via the proximal thread 17 and in the relatively open-pored spongiosa via the cementing section 29 at the femur. The prosthesis shaft 11 is thus fixed in the femur practically over its total axial length without external pressing devices or clamping devices being  
5 necessary to fasten the prosthesis shaft 11.

The third embodiment of a prosthesis shaft 11 shown in Fig. 6 differs from the two previously described embodiments by the design of the cementing section 29. The recesses 19 which are in turn provided and extend in the  
10 axial direction between web-like wall sections 23 are not open to distal here and are not directly filled with bone cement. The cementing section 29 is rather provided with an axially extending, central introduction channel 25 which is accessible from distal and communicates with the recesses 19 via radial openings 26. These openings 26 are arranged offset  
15 to one another with respect to the axial direction. In the region of its distal end, the cementing section 29 is provided with a threaded section 31 which serves as a seal on the introduction of the bone cement, as will be looked at in more detail in the following. The threaded section 31 is calibrated to the proximal anchorage thread 17 and is in particular  
20 designed as its prolongation. Since the primary purpose of the threaded section 31 is not the anchorage of the shaft 11 in the femur bone, the threaded section 31 can e.g. be made from a bioabsorbable material. The distal end face of the cementing section 29 is provided with two cut-outs 28 diametrically opposed to one another. As Fig. 7 shows, these cut-outs  
25 28 serve for the reception of correspondingly shaped projections 44 of a screwing instrument 43 with which the shaft 11 is screwed into the previously manufactured passage 21 in the femur bone. Not only this screwing instrument 43, but also the instrument 45 for the introduction of

bone cement differs from the corresponding instrument for the first and second embodiments. As Fig. 8 shows, the contact region 48 of the grommet 47 sealing the distal end of the cementing section 29 in the mounted state has a radial inner ring wall 42, which outwardly seals the channel 25 of the cementing section 29, in addition to a radially outer ring wall which outwardly encompasses the distal end of the cementing section 29. Unlike the introduction instrument for the first and second embodiments of the prosthesis shaft, the radially outer ring wall of the contact region 48 does not have any guidance or sealing function in the introduction instrument 45 shown in Fig. 8. The axially extending channel 25 and the openings 26 opening into the recesses 19 provide a radial outflow of the bone cement from the recesses 19. The sealing of the passage 21 is ensured by the seal 31 made as a thread.

The prosthesis shaft 11 of the third embodiment in accordance with Fig. 9 is thus also anchored reliably at the femur bone via the thread 17 in the comparatively hard material of the neck of the femur and via the bone cement cooperating with the cementing section 29 in the comparatively open-pored material of the spongiosa.

20

Irrespective of which cementing section 29 is used for the prosthesis shaft 11, the routine of the surgical procedure for the insertion of the prosthesis is as follows:

First, the femoral head is cut off and removed via a front access (anterior). Then either the acetabulum of the hip bone is immediately machined, and indeed likewise through the mentioned front access, or the trepanning bore 51 (cf. e.g. Fig. 2) anyway required is first established. This is done

with the help of a computer-aided optical navigation system. For the machining of the acetabulum via the trepanning bore 51, a machining sleeve (not shown) is pushed into the latter and the instruments required for the machining of the acetabulum can subsequently be supplied via it..

5 The correct alignment of the femur bone relative to the hip bone required in this process can be fixed in that the machining sleeve is dimensioned such that it projects laterally out of the femur of the patient and is held at the operation table by suitable means. The subsequent insertion of the prosthesis shell (not shown) takes place in turn via the mentioned front

10 access. Then, after removal of the machining sleeve, a throughgoing internal thread for the prosthesis shaft 11 is formed in the trepanning bore 51 by means of the thread cutter. Subsequently, the prosthesis shaft 11 is screwed into a depth previously fixed as part of the operation planning by means of the screwing instrument 43 (cf. Fig. 3 or Fig. 7).

15 Then - again via the mentioned front access - the prosthesis head 15 is inserted and mounted onto the cone 15 of the prosthesis shaft 11. The blows onto the head 15 required for the fixing of the head 15 on the cone 13 are also carried out through the front access by means of

20 corresponding instruments not shown here. Subsequently, the correct position of the prosthesis head 15 can be inspected and, if necessary, corrected by rotating the prosthesis shaft 11 in the passage 21. If the correct position, i.e. the correct depth of the prosthesis shaft 11 in the passage 21, has been reached, the prosthesis shaft 11 is cemented in with the aid of the introduction instrument 45 (cf. Fig. 4 or Fig. 8). For this

25 purpose, the respective "grommet" 47, which is attached to a conventional cement syringe, is mounted onto the distal end of the prosthesis shaft 11, as was explained above. As soon as the cement has hardened, the

prosthesis shaft 11 is not only reliably anchored in the femur bone via its thread 17, but also via the cementing section 29.

5 A property of the prosthesis set forth here comprises the fact that it is possible to work only with minimally invasive surgical procedures and that an insertion of the shaft from lateral can take place, with only the mounting of the prosthesis head having to take place from medial.

10 It is to be understood that, if any prior art publication is referred to herein, such reference does not constitute an admission that the publication forms a part of the common general knowledge in the art, in Australia or any other country.

Reference numeral list

	11	shaft of the prosthesis
	13	proximal end section, coupling section, cone
5	15	head of the prosthesis
	17	thread of the prosthesis shaft, spongiosa thread
	19	recess, mount
	21	passage
	23	wall section, web
10	25	channel
	26	opening
	27	anchorage section with thread
	28	cut-out for screwing instrument
	29	anchorage section with recess, cementing section
15	31	sealing section, rear threaded section
	33	connection spigot
	35	spigot mount
	41	thread cutter
	42	radially inner ring wall
20	43	screwing instrument
	44	projection of the screwing instrument
	45	introduction instrument, cement syringe or cement gun
	47	introduction section, grommet
	48	contact region
25	49	finger of the screwing instrument
	51	trepanning bore

**CLAIMS DEFINING THE INVENTION ARE AS FOLLOWS:**

1. A shaft for a femoral neck prosthesis, comprising an anchorage region provided for arrangement in the interior of the femur for the anchorage of the prosthesis in the bone, a head region which adjoins the anchorage region axially at a proximal side and has a device for connection to a prosthesis head, and a distal end which is disposed opposite the head region in the axial direction of the anchorage region;
- 5
- 10            wherein the maximum cross-sectional dimension of the head region is at most the same size as, and preferably smaller than, a maximum diameter of the anchorage region such that the maximum cross-sectional dimension of the shaft is present in the anchorage region;
- 15            wherein the anchorage region includes an external thread section with a spongiosa thread;
- wherein the external thread section is arranged adjacent to the head region; and
- 20            wherein the shaft is arranged such that the shaft can be inserted through a passage formed in the femur from a lateral side of the femur and can be secured within that passage by means of the anchorage region.
2. A shaft for a femoral neck prosthesis, comprising an anchorage region provided for arrangement in the interior of the femur for the anchorage of the prosthesis in the bone, a head region which adjoins the anchorage region axially at a proximal side and has a device for connection to a prosthesis head, and a distal end which is disposed opposite the head region in the axial direction of the anchorage region;
- 25
- 30

wherein the maximum cross-sectional dimension of the head region is at most the same size as, and preferably smaller than, a maximum diameter of the anchorage region such that the maximum cross-sectional dimension of the shaft is present in the anchorage region;

5

wherein the anchorage region includes a cementing section;

wherein the anchorage region includes an external thread section with a spongiosa thread, wherein the external thread section is arranged adjacent to the head region;

10

wherein the cementing section adjoins the threaded section at distal; and

wherein the shaft is arranged such that the shaft can be inserted through a passage formed in the femur from a lateral side of the femur and can be secured within that passage by means of the anchorage region.

15

3. A shaft in accordance with claim 1, wherein the anchorage region includes a cementing section.

20 4. A shaft in accordance with claim 2 or 3, wherein the cementing section has at least one recess for the reception of bone cement at its outer periphery.

25 5. A shaft in accordance with claim 4, wherein the cementing cross-section has a geometry of cross-shape or star shape in cross-section at least in an axial region, with substantially axially extending recesses being formed.

30 6. A shaft in accordance with claim 5, wherein the recesses extend up to the distal end of the cementing section.

7. A shaft in accordance with claim 4, wherein the cementing section has at least one spirally or annularly circumferential groove as a recess for the reception of bone cement.
- 5 8. A shaft in accordance with any one of the claims 4-7, wherein the recess is accessible from the distal end of the shaft.
9. A shaft in accordance with any one of the claims 4-8, wherein the shaft has means which ensure a fluid communication for the  
10 supply of bone cement from the distal end of the shaft to the recess.
10. A shaft in accordance with any one of the preceding claims, wherein the spongiosa thread has a substantially constant core diameter  
15 and/or a substantially constant external diameter.
11. A shaft in accordance with any one of the preceding claims, wherein the maximum diameter of the external thread defines the maximum diameter of the shaft.  
20
12. A shaft in accordance with any one of the preceding claims, wherein the thread height amounts to at least 3 mm and preferably to at least 4.5 mm.
- 25 13. A shaft in accordance with any one of the preceding claims, wherein the maximum cross-sectional dimension of the head region exceeds the maximum core diameter of the thread by a maximum of 1/3 of the difference between the maximum external diameter and the maximum core diameter of the thread, and is preferably at  
30 most of the same size as the maximum core diameter of the thread.

14. A shaft in accordance with claim 1 or any one of claims 3-13 when dependent on claim 1 wherein the shaft has a cementing section.
- 5 15. A shaft in accordance with claim 14, wherein the cementing section adjoins the threaded section at distal.
- 10 16. A shaft in accordance with any one of claims 2, 14, 15 or any one of claim 4-13 when dependent on claim 2, wherein the maximum cross-sectional dimension of the cementing section exceeds the maximum core diameter of the thread by a maximum of 1/3 of the difference between the maximum external diameter and the maximum core diameter of the thread, and is preferably at most the same size as the maximum core diameter of the thread.
- 15 17. A shaft in accordance with any one of the claims 2, 14-16 or any one of claims 4-13 when dependent on claim 2 wherein the maximum cross-sectional dimension of the cementing section is at least the same size as the maximum cross-sectional dimension of the head region.
- 20 18. A shaft in accordance with any one of the preceding claims, wherein the anchorage region includes a cementing section, with the cementing section including a sealing section in the region of its distal end.
- 25 19. A shaft in accordance with claim 18, wherein the sealing section is made in thread form.
- 30 20. A shaft in accordance with claim 19, wherein the anchorage region includes an external thread section with a spongiosa thread, with the thread-shaped sealing section corresponding to the spongiosa

thread, preferably with respect to the dimension of the external diameter and/or of the thread height.

- 5 21. A shaft in accordance with any one of the preceding claims, wherein the head region and the anchorage region are arranged coaxially.
- 10 22. A shaft in accordance with any one of the preceding claims, wherein the anchorage region includes a cementing region and an external thread section, with the head region and the cementing section and/or the external thread section being arranged coaxially, or with the cementing section and the external thread section being arranged coaxially.
- 15 23. A shaft in accordance with any one of the preceding claims, wherein the proximal to distal extent of the anchorage region is dimensioned such that the distal end of the shaft comes to lie in the spongiosa tissue of the femur.
- 20 24. A shaft in accordance with any one of the preceding claims, wherein the head region has a conical or truncated conical connection element for connection to a prosthesis head.
- 25 25. A shaft substantially as herein described with reference to the drawings.

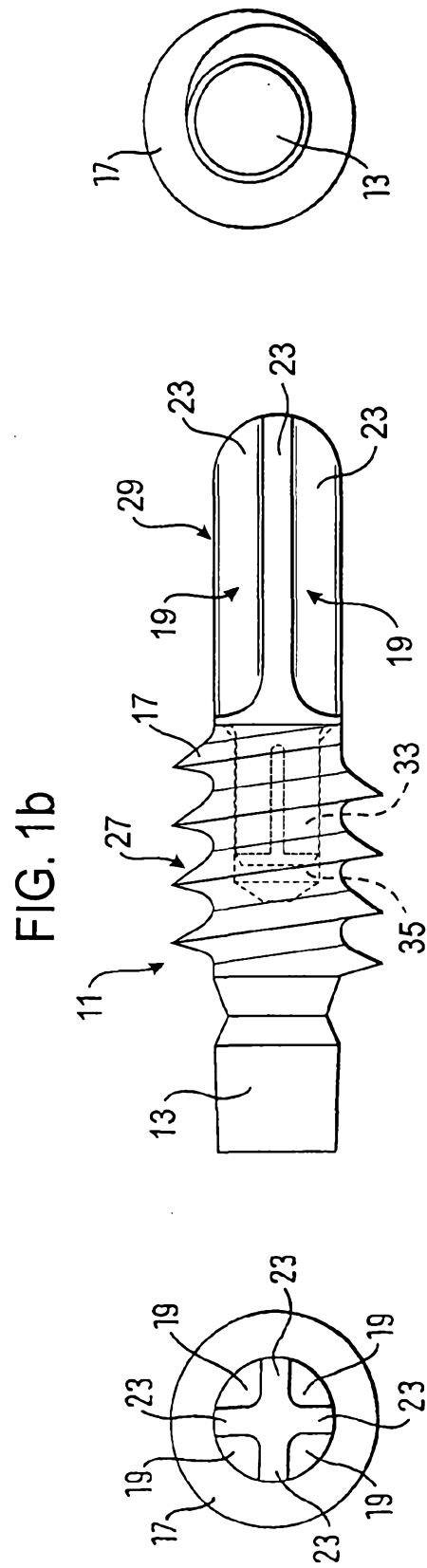
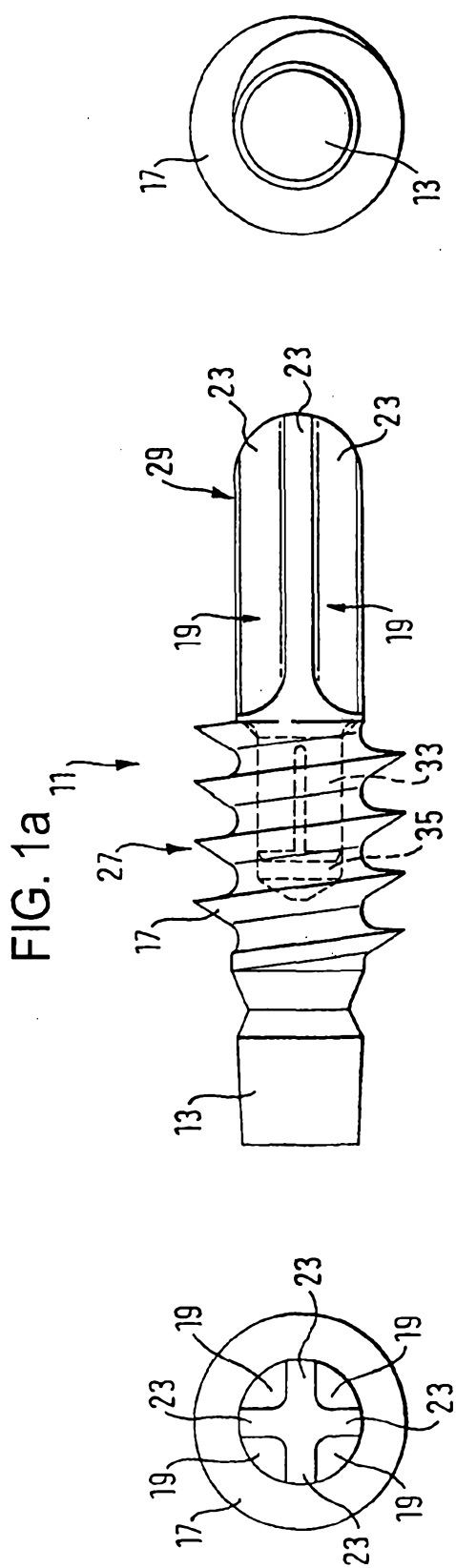

FIG. 2

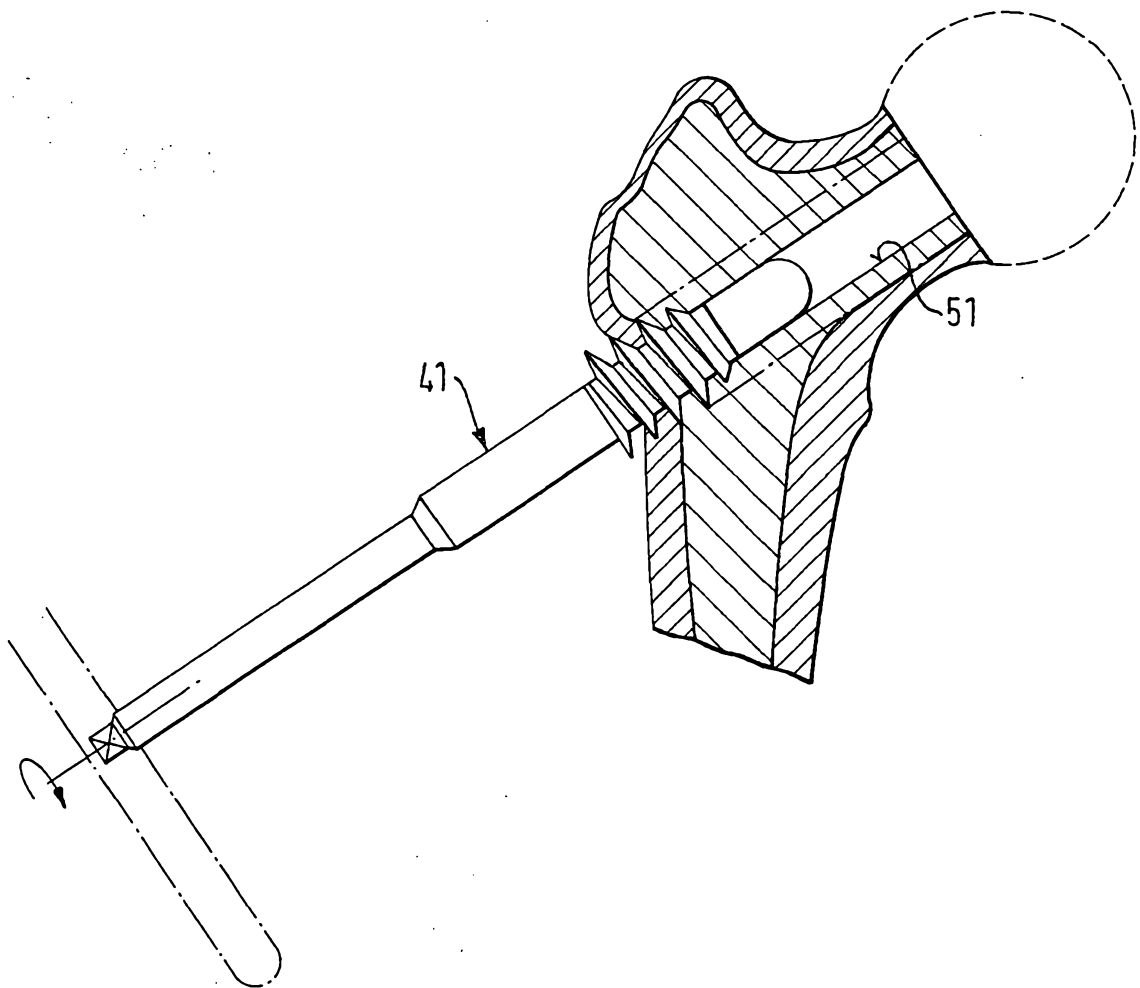

FIG. 3

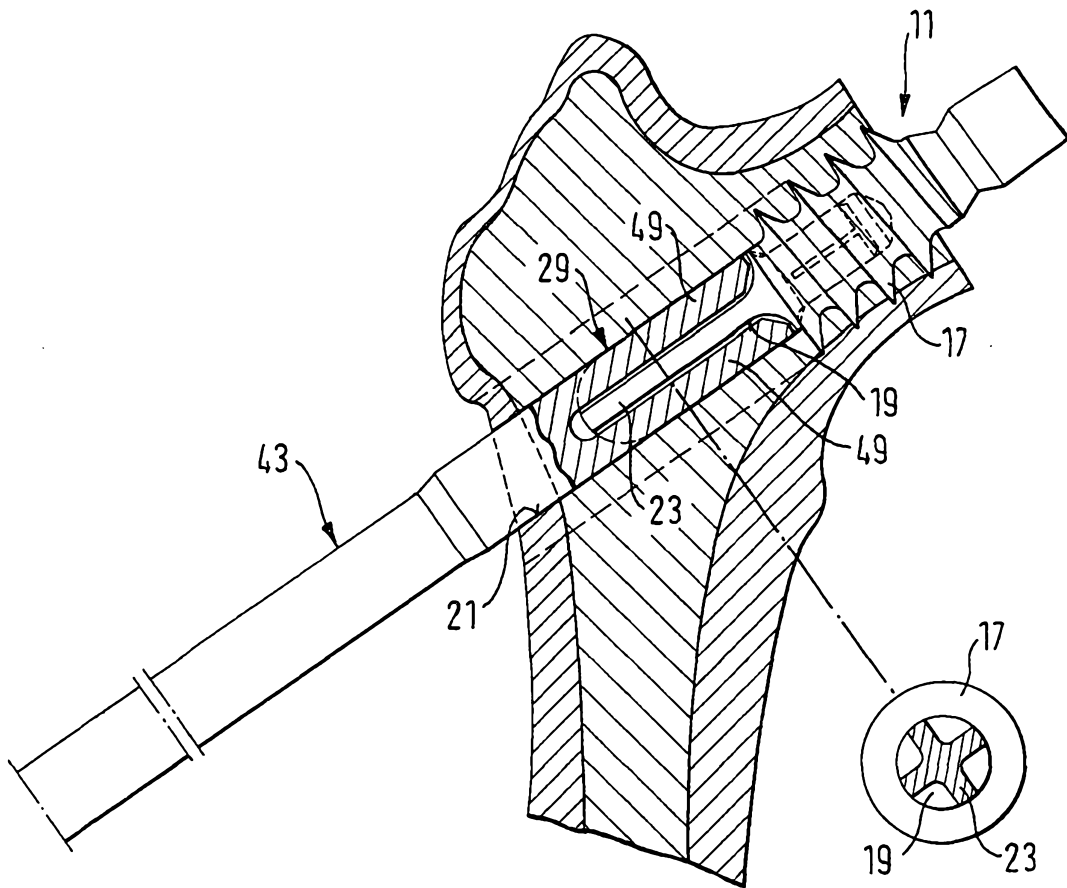

FIG. 4

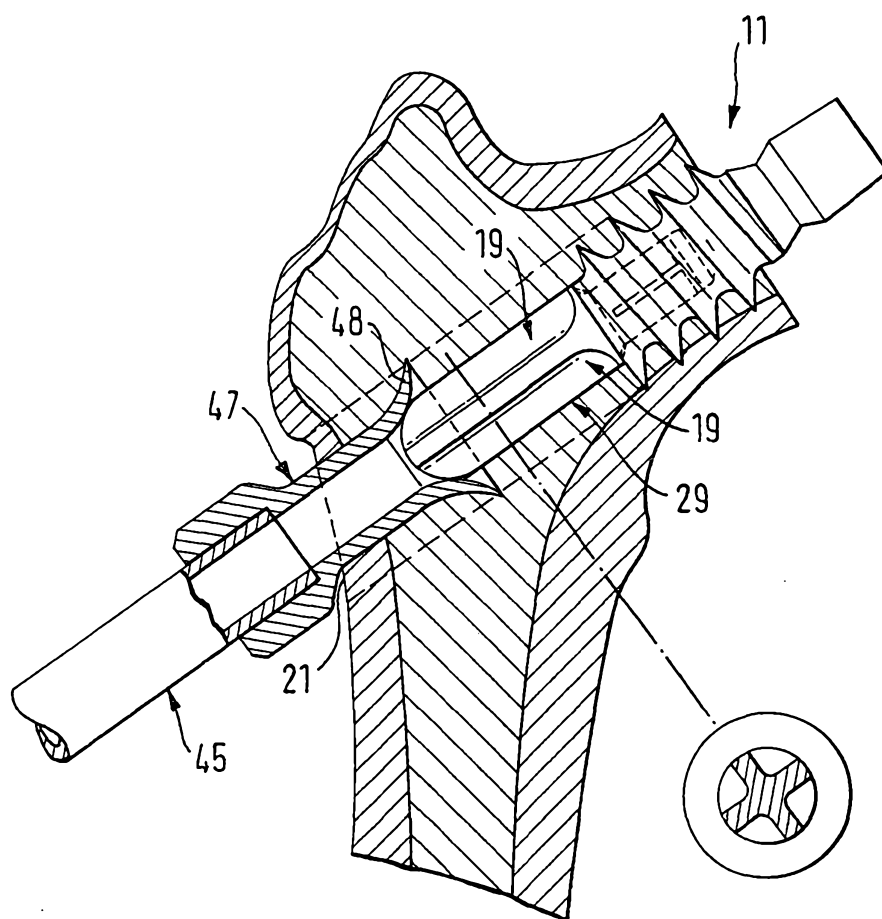

FIG. 5

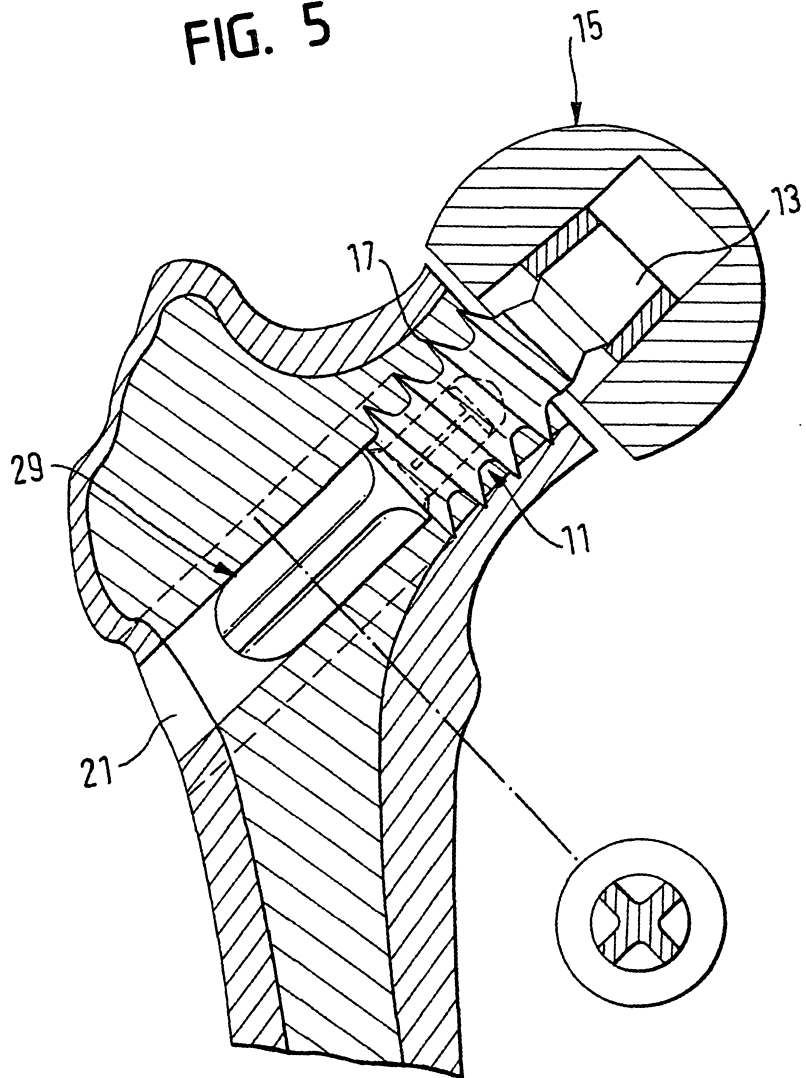
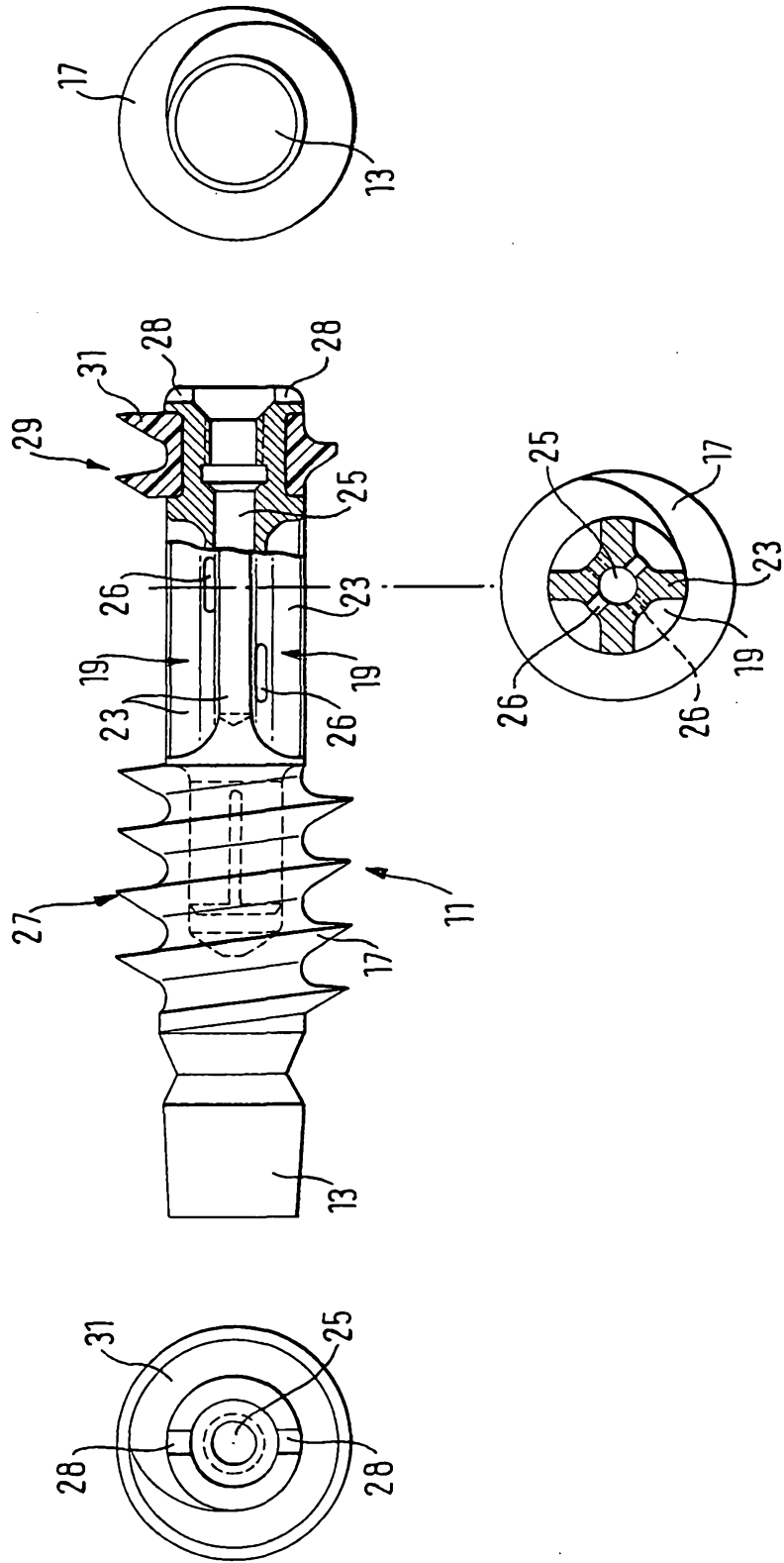

FIG. 6



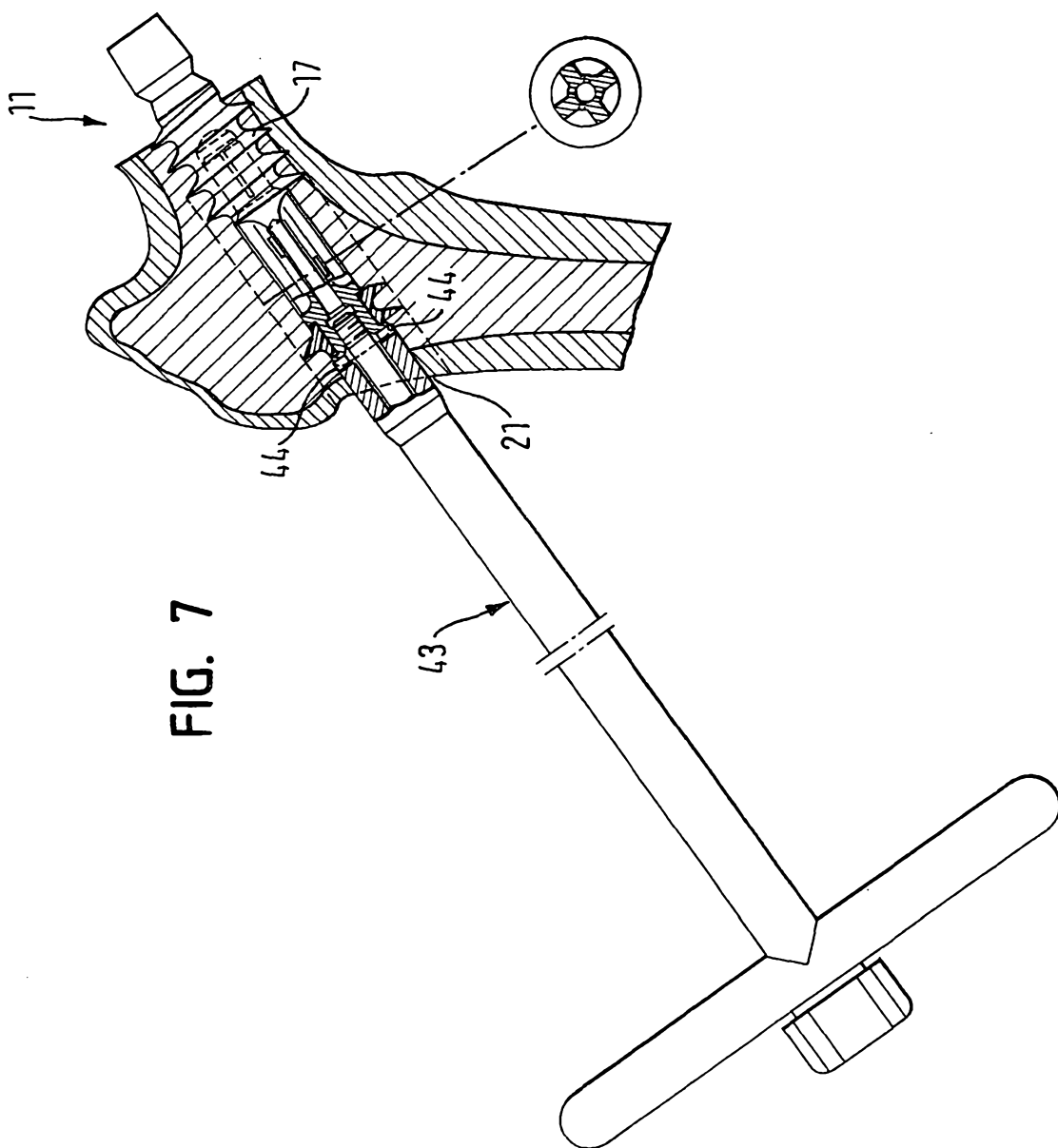

FIG. 7



FIG. 9

