



- (51) **International Patent Classification:**
G02B 6/38 (2006.01)
- (21) **International Application Number:**
PCT/EP2014/051706
- (22) **International Filing Date:**
29 January 2014 (29.01.2014)
- (25) **Filing Language:** English
- (26) **Publication Language:** English
- (30) **Priority Data:**
61/758,051 29 January 2013 (29.01.2013) US
61/758,180 29 January 2013 (29.01.2013) US
- (71) **Applicant:** TYCO ELECTRONICS RAYCHEM BVBA [BE/BE]; Diestsesteenweg 692, B-3010 Kessel-Lo (BE).
- (72) **Inventors:** VAN BAELEN, David Jan Irma; Dieriksgroebe 6a, B-3020 Winksele (BE). WILLAERT, Sabrina; Stationsstraat 129, B-2860 Sint-Katelijne-Waver (BE). BRYON, Roel Modest Willy; Tieltsebaan 16, B-3200 Aarschot (BE).
- (74) **Agent:** OBST, Bernhard; Patentanwälte Bressel und Partner mbB, Potsdamer Platz 10, 10785 Berlin (DE).

(81) **Designated States** (unless otherwise indicated, for every kind of national protection available): AE, AG, AL, AM, AO, AT, AU, AZ, BA, BB, BG, BH, BN, BR, BW, BY, BZ, CA, CH, CL, CN, CO, CR, CU, CZ, DE, DK, DM, DO, DZ, EC, EE, EG, ES, FI, GB, GD, GE, GH, GM, GT, HN, HR, HU, ID, IL, IN, IR, IS, JP, KE, KG, KN, KP, KR, KZ, LA, LC, LK, LR, LS, LT, LU, LY, MA, MD, ME, MG, MK, MN, MW, MX, MY, MZ, NA, NG, NI, NO, NZ, OM, PA, PE, PG, PH, PL, PT, QA, RO, RS, RU, RW, SA, SC, SD, SE, SG, SK, SL, SM, ST, SV, SY, TH, TJ, TM, TN, TR, TT, TZ, UA, UG, US, UZ, VC, VN, ZA, ZM, ZW.

(84) **Designated States** (unless otherwise indicated, for every kind of regional protection available): ARIPO (BW, GH, GM, KE, LR, LS, MW, MZ, NA, RW, SD, SL, SZ, TZ, UG, ZM, ZW), Eurasian (AM, AZ, BY, KG, KZ, RU, TJ, TM), European (AL, AT, BE, BG, CH, CY, CZ, DE, DK, EE, ES, FI, FR, GB, GR, HR, HU, IE, IS, IT, LT, LU, LV, MC, MK, MT, NL, NO, PL, PT, RO, RS, SE, SI, SK, SM, TR), OAPI (BF, BJ, CF, CG, CI, CM, GA, GN, GQ, GW, KM, ML, MR, NE, SN, TD, TG).

Published:
— with international search report (Art. 21(3))

(54) **Title:** FIBER OPTIC CONNECTION SYSTEM

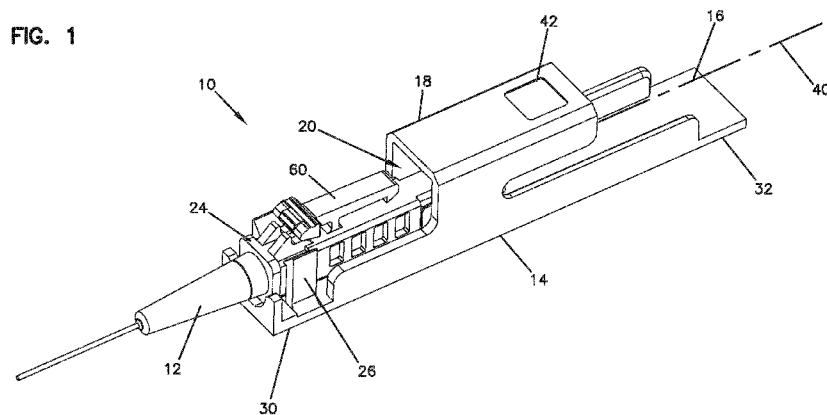

(57) **Abstract:** A fiber optic connector (12) is mounted to a fiber optic connector holder (14). The holder (14) can be a separate piece mountable to other devices, such as trays, panels, modules, cassettes, and chassis. Alternatively, the holder (14) can be integrally formed with the device. In some implementations, multiple holders (14) can be provided as separate elements, or as an integral element. The fiber optic connector holder (14) holds the fiber optic connector (12) in position ready for connection to another fiber optic connector (50) at a desired time. The holder (14) receives a fiber optic adapter (36), and a second fiber optic connector (50). The adapter (36) aligns the two connectors (12, 50) for fiber optic signal transmission. The fiber optic connector holder (14) includes a clip (26) for clipping to the first connector (12).



FIBER OPTIC CONNECTION SYSTEM

Background

Fiber optic connectors are known for connecting fiber optic cables to
5 other fiber optic cables or fiber optic equipment. In many situations, a fiber optic
adapter is used to align two fiber optic connectors to allow signal transmission between
two optical fibers of the cables terminated by the fiber optic connectors.

Summary of the Invention

In one implementation, a fiber optic connector is mounted to a fiber optic
10 connector holder. The holder can be a separate piece mountable to other devices, such
as trays, panels, modules, cassettes, and chassis. Alternatively, the holder can be
integrally formed with the device. In some implementations, multiple holders can be
provided as separate elements, or as an integral element.

The fiber optic connector holder holds the fiber optic connector in
15 position ready for connection to another fiber optic connector at a desired time. The
holder receives a fiber optic adapter, and a second fiber optic connector. The adapter
aligns the two connectors for fiber optic signal transmission.

In one example, the fiber optic connector holder includes a clip for
clipping to the connector. In some implementations, the clip is releasable.

Brief Description of the Figures

20 Figure 1 is a perspective view of a fiber optic connector mounted to a
fiber optic connector holder;

Figure 2 is a further perspective view of the fiber optic connector and the
fiber connector holder of Figure 1;

25 Figure 3 is a side view of the fiber optic connector and the fiber optic
connector holder of Figure 1;

Figure 4 is a top view of the fiber optic connector and the fiber optic
connector holder of Figure 1;

- Figure 5 is a perspective view of the fiber optic connector holder;
- Figure 6 is another perspective view of the fiber optic connector holder;
- Figure 7 shows a fiber optic adapter being mounted to the fiber optic connector held by the fiber optic connector holder of Figure 1;
- 5 Figure 8 is a further view of the fiber optic adapter being mounted to the fiber optic connector;
- Figure 9 is a side view of the fiber optic adapter being mounted to the fiber optic connector;
- Figure 10 is a cross-sectional side view of the view of Figure 9;
- 10 Figure 11 is a perspective view of the fiber optic adapter fully mounted to the fiber optic connector;
- Figure 12 is a further perspective view of the fiber optic adapter mounted to the fiber optic connector;
- Figure 13 is a perspective view showing a second fiber optic connector mounted to the fiber optic adapter for optical signal transmission between two fiber optic cables;
- 15 Figure 14 is a further perspective view of the view of Figure 13;
- Figure 15 is a side view of the view of Figure 13;
- Figure 16 is a top view of the view of Figure 13;
- 20 Figure 17 is an exploded perspective view showing two fiber optic connectors separated from a mating fiber optic adapter;
- Figure 18 shows a plurality of fiber optic connector holders mounted in a mounting arrangement for holding a plurality of first fiber optic connectors, mating fiber optic adapters, and second fiber optic connectors;
- 25 Figure 19 is a further perspective view of the fiber optic connector holder mounting arrangement of Figure 18;
- Figure 20 is a perspective view of the fiber optic connector holder mounting arrangement without the connectors or adapters shown;
- Figure 21 is an example implementation of a connector holder system
- 30 utilizing the connector holder implementations of Figures 1-20;

Figure 22 is another example implementation of a connector holder system utilizing the connector holder implementations of Figures 1-20;

Figure 23 is a further example implementation of a connector holder system utilizing the connector holder implementations of Figures 1-20;

5 Figure 24 is a further example implementation of a connector holder system utilizing the connector holder implementations of Figures 1-20.

Detailed Description

Referring now to Figures 1-6, a connector holder system 10 is shown. System 10 includes a fiber optic connector holder 14 which holds a first fiber optic
10 connector 12. System 10 maintains first connector 12 in a protected and organized manner for later connection to a second fiber optic connector. System 10 also does not require a fiber optic adapter for holding the first connector 12 before connection to the second connector. With system 10, a connector only approach is provided wherein only the one or more first connectors 12 are held and maintained ready for connection to an
15 adapter and one or more second connector as desired by the user.

Holder 14 includes a base 16 and a housing 18. Housing 18 defines a pocket 20 for receipt of a distal end 22 of first connector 12. Pocket 20 also receives an adapter as will be described below. Holder 14 includes a clip 26 which clips to first
20 connector 12 to hold first connector 12 to holder 14. As shown, clip 26 clips to a rear 24 of first connector 12. Clip 26 is located at end 30 of holder 14. Clip 26 is u-shaped and includes two clip arms 48.

As shown in Figures 7-12, an adapter 36 is inserted into an opposite end
32 of holder 14 for mating connection with first connector 12. Adapter 36 is inserted along a longitudinal axis 40 into pocket 20 and latches to first connector 12. Adapter 36
25 is not latched to holder 14 wherein movement in the axially direction would be prevented. Instead, axial movement is controlled by clip 26 mounted to first connector 12.

Adapter 36 includes posts 46 which slide along slots 28 of holder 14 to provide proper alignment with first connector 12. Pocket 20 does provide some support

to adapter 36. The main fixation of the mating connectors and adapter is between first connector 12 and holder 14.

Once adapter 36 is mated with first connector 12, a second connector 50 is mated with adapter 36. See FIGS. 13-16. Once second connector 50 is mated with
5 adapter 36, fiber optic signals can be transmitted between a first cable 54 and a second cable 56. Once both connectors are mated to adapter 36, the fiber optical fibers within each of the first and second connectors 12, 50 and cables 54, 56 are in optical alignment.

If desired, second connector 50 can be pre-mated with adapter 36, and
10 then the combined adapter 36 and second connector 50 can be inserted into holder 14 for mating with first connector 12.

First connector 12 includes a shutter 34 for protecting the user and others before connection to the second connector 50. Second connector 50 also preferably includes a shutter.

15 Holder 14 includes an RFID tag location 42 for holding an RFID tag, if desired. Holder 14 can be provided with holes 44 (see FIGS. 5 and 6) to allow for RFID tags on the connectors to be read while positioned in holder 14. RFID tags allow for identification of specific connectors and adapters.

Holder 14 is shown with a closed housing 18 defining pocket 20.
20 Housing 18 is optional if desired. An open topped base 16 can be provided.

Holder 14 can be used as a system demarcation location. In some implementations, first connectors 12 cannot be removed, if desired. Only adapters 36 and second connectors 50 would be accessible in that case.

Referring now to Figure 17, adapter 36 is shown separated from first
25 connector 12 and second connector 50. In use, connectors 12, 50 mount to adapter 36 with latches 60. During insertion of connectors 12, 50 into adapter 36, shutters 34 lift up exposing the optical fiber inside of connectors 12, 50. Further descriptions of the functions and structures of first connector 12 and second connector 50 and the mating adapter 36 are shown in U.S. Patent Application Serial No. 61/758,021, entitled Optical
30 Fiber Connection System Including Optical Fiber Alignment Device, filed January 29, 2013, and WO 2013/117598, Published August 15, 2013, the disclosures of which are

incorporated by reference. The first and second connectors 12, 50 and mating adapter 36 are shown in the drawings as one example implementation. It is to be appreciated that other connectors and adapters could be used as desired wherein the connector (for example, LC, SC, MPO) is mounted to a holder configured to mount to the connector, instead of the adapter.

Referring now to Figures 18-20, a mounting arrangement 70 is shown with a plurality of holders 14. Holders 14 can be separate elements held together with a mounting structure, or mounting arrangement 70 can be made with integrally formed holders 14.

A single holder 14 or a plurality of holders 14, such as mounting arrangement 70, can be mounted to a tray, a panel, a module, a cassette, a chassis, or other telecommunications equipment, as desired. In the example implementation, clip 26 is releasable for removing first connector 12. Other mounting structures can be used instead of clip 26 to mount first connector 12 to holder 14.

Figures 21-24 show various implementations of mounting arrangements 70 including a plurality of holders 14, either separately mounted, or integrally formed therewith for holding a plurality of connectors prior to connections with an adapter and a second connector. The mounting arrangements 70 can be moveably mounted for improved user access too, as desired.

Referring now to Figure 21, a first tray 100 is shown including a mounting arrangement 70 in the form of a single row of fiber optic connector holders 14. First tray 100 can include other cable management structures 102 such as a cable pass through 104 and a cable storage area 106.

Referring now to Figure 22, a second tray 200 is shown with a mounting arrangement 70 in the form of a single row of fiber optic connector holders 14. Second tray 200 includes a tray base 202 and a pivotable cover 204. Posts 46 on adapters 36 are held in slots 206 when cover 204 is closed. Fixation is by the first connectors 12 (not shown) within the interior second tray 200. Slots 206 provide an additional load bearing structure in situations where an extra load may be placed on second connectors 50 and cables 56. However, the engagement of posts 46 and slots 206 does not interfere with the fiber optic signal pathway alignment between the first and second connectors

12, 50, since the primary fixation is by tray 200, holders 14 and first connectors 12 inside of tray 200. Posts 46 allow for rotation of adapter 36 to help avoid stress on the fiber to fiber alignment. Adapters 36 can be removed from the interiorly located first connectors 12 by engagement with buttons 210. Button 210 engages the connector latch 60 on first connector 12 disposed within the closed interior of a rear portion 212 of second tray 200.

Referring now to Figure 23, a panel 300 is shown including a plurality of rows 302 of holders 14. Holders 14 are provided in mounting arrangements 70 which are pivotable up and down relative to one another to allow for connector access. Such pivoting will also allow for improved access to individual RFID tags associated with the adapters 36, and the related connectors 12, 50.

Referring now to Figure 24, a mounting block 400 is shown with a plurality of rows 402 of holders 14. As with panel 300, mounting block 400 also includes a dense arrangement of the adapters 36 and the first and second connectors 12, 50 in mounting arrangement 70. Rows 402 pivot about an axis which is parallel to the connector axis for each of the connectors for improved access to the adapters 36 and connectors 12, 50.

Connector holder system 10 and the various implementations noted above holds the connector of one of the mated connector pairs, instead of the mating adapter 36. In general, it is not desirable to precisely fix to a holder, tray, or other device both of the mating connectors and the mating adapter. Tolerance offsets, and misalignments may interfere with proper fiber alignment and signal transmission. In the present implementations, the connector 12 is the primary fixation of the system 10. If there is additional fixation provided, such as for load bearing situations, it does not interfere with the connector 12 to holder 14 fixation, or the fiber to fiber alignment.

One result of providing a connector holder system 10 as described herein is that the adapters 36 can be added at a later date, when desired. In the implementations shown above, the connector 12 is protected without the need for an adapter.

The above specification, examples and data provide a complete description of the manufacture and use of the composition of the invention. Since many

embodiments of the invention can be made without departing from the spirit and scope of the invention, the invention resides in the claims hereinafter appended.

	10	Connector holder system
	12	First fiber optic connector
	14	Fiber optic connector holder
	16	Base
5	18	Housing
	20	Pocket
	22	Distal end of first connector
	24	Rear of first connector
	26	Clip
10	28	Slots
	30	End of holder
	32	Opposite end of holder
	34	Shutter
	36	Adapter
15	40	Longitudinal axis
	42	RFID tag location
	44	Holes
	46	Posts
	48	Clip arms
20	50	Second fiber optic connector
	54	First cable
	56	Second cable
	60	Latch
	70	Mounting arrangement
25	100	First tray
	102	Structures
	104	Cable pass through
	106	Cable storage area
	200	Second tray
30	202	Base
	204	Cover

	206	Slots
	210	Buttons
	212	Rear Portion
	300	Panel
5	302	Rows
	400	Mounting block
	402	Rows

1. A fiber optic connection system (10) comprising:
 - a first fiber optic connector (12);
 - a holder (14) mounted to the first fiber optic connector (12), wherein the holder (14) is capable of receiving a fiber optic adapter (36) for mating with the first fiber optic connector (14), the fiber optic adapter (36) matable with a second fiber optic connector (50).
2. The system of claim 1, wherein the holder (14) includes a clip (26) for mounting of the connector to the holder (14).
3. The system of claim 2, wherein the clip (26) is releasable for releasable connection to the first connector (12).
4. The system of claims 1-3, wherein the holder (14) includes adapter engagement features.
5. The system of claims 1-4, further comprising a plurality of first connectors (12), and a plurality of holders (14).
6. The system of claim 5, wherein the plurality of holders (14) are arranged in at least one row.
7. The system of claim 6, wherein the plurality of holders (14) are arranged in a plurality of rows.
8. The system of any of claims 1-7, further comprising a release mechanism for releasing a connector latch from the adapter.
9. A method of using a connector comprising:
 - providing a first fiber optic connector (12);

providing a holder (14);

mounting the first fiber optic connector (12) to the holder (14), wherein the holder (14) is capable of receiving a mating fiber optic adapter (36) and a second fiber optic connector (50) matable with the fiber optic adapter (36) at a later time.

10. The method of claim 9, further comprising mounting a fiber optic adapter (36) to the first fiber optic connector (12) while the first fiber optic connector (12) is mounted to the holder (14).

11. The method of claim 10, further comprising mounting a second fiber optic connector (50) to the fiber optic adapter (36).

12. The method of claim 11, wherein the second fiber optic connector (50) is mounted to the fiber optic adapter (36) before the fiber optic adapter (36) is mounted to the first fiber optic connector (50).

13. The method of claim 11, wherein the second fiber optic connector (50) is mounted to the fiber optic adapter (36) after the fiber optic adapter (36) is mounted to the first fiber optic connector (50).

14. The method of any of claims 9-13, wherein a plurality of first fiber optic connectors (12) are provided mounted to one or more holders (14).

15. The method of any of claims 9-14, further comprising a release mechanism for releasing a connector latch from the adapter.

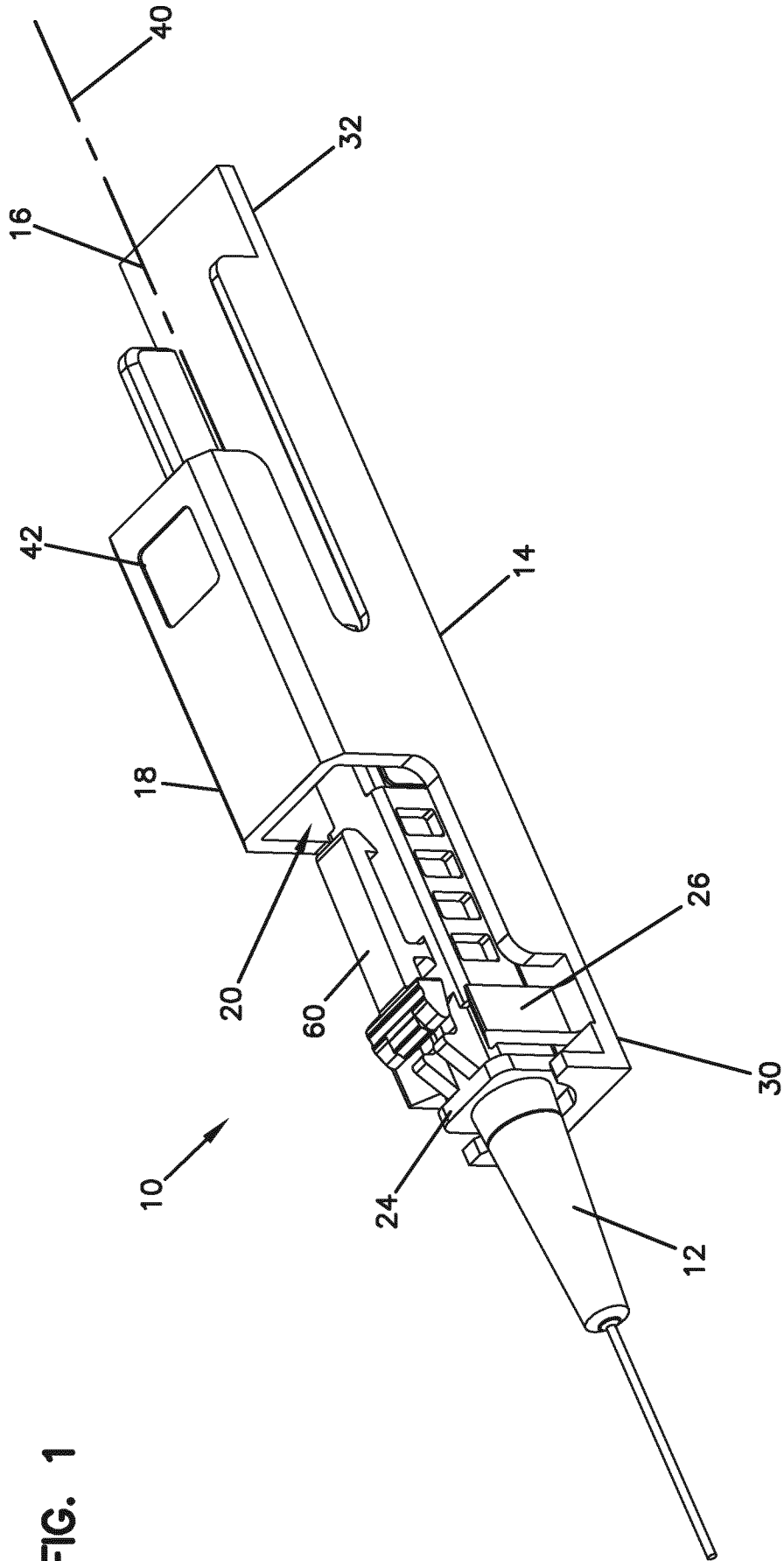

FIG. 1

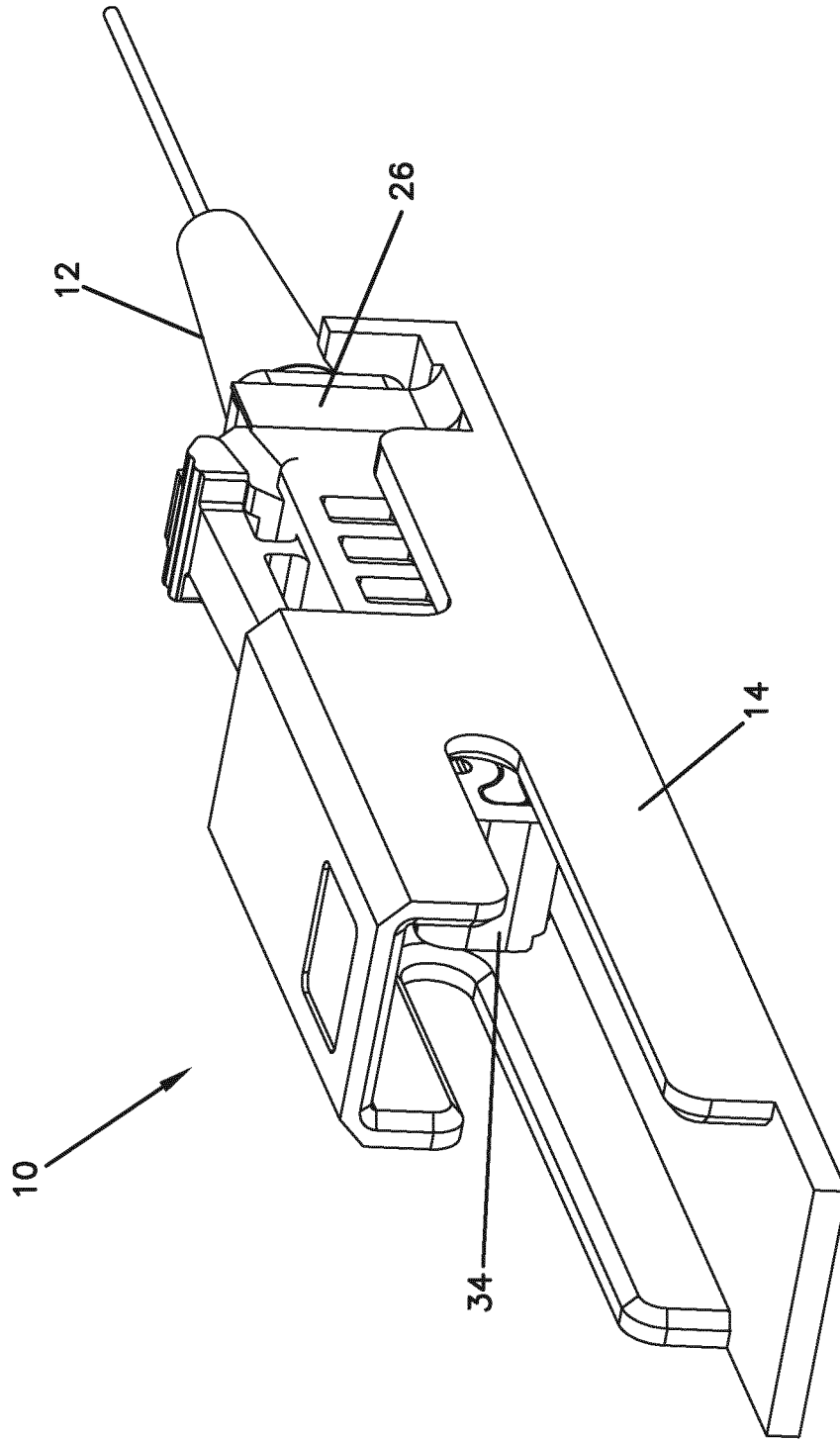

FIG. 2

FIG. 3

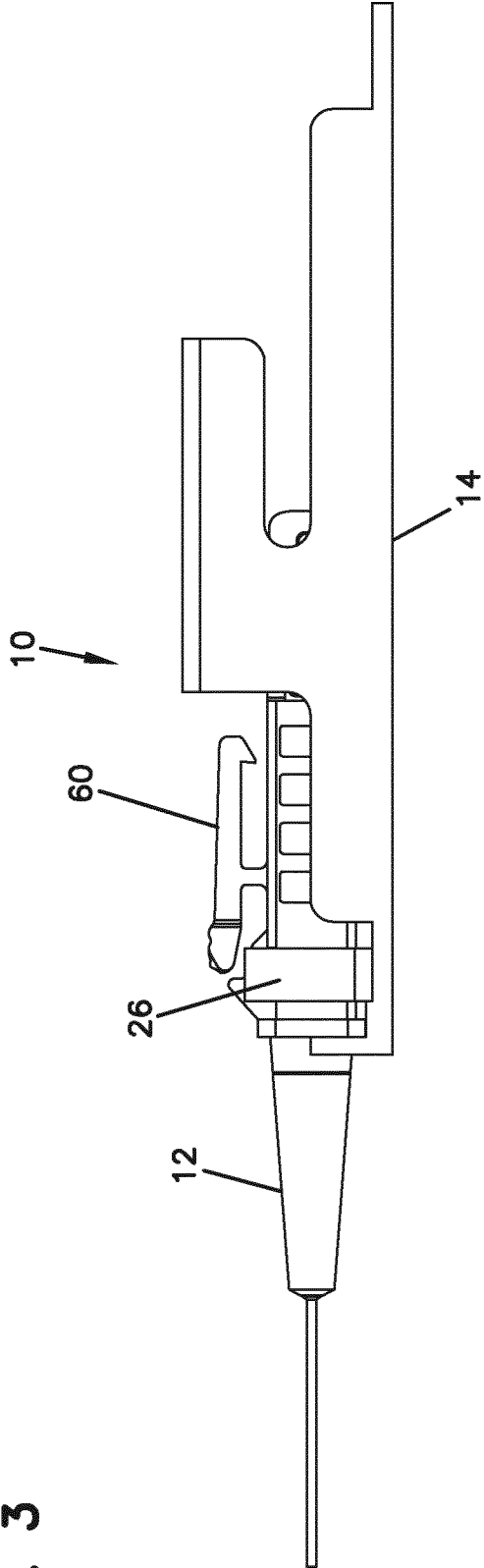

FIG. 4

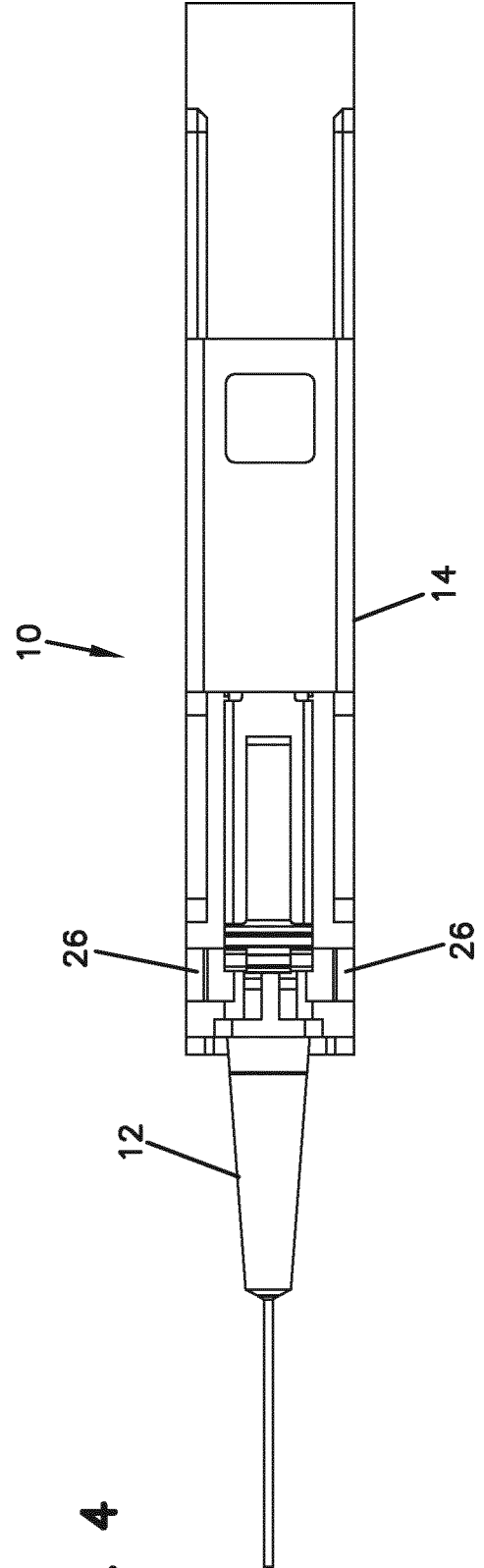

FIG. 5

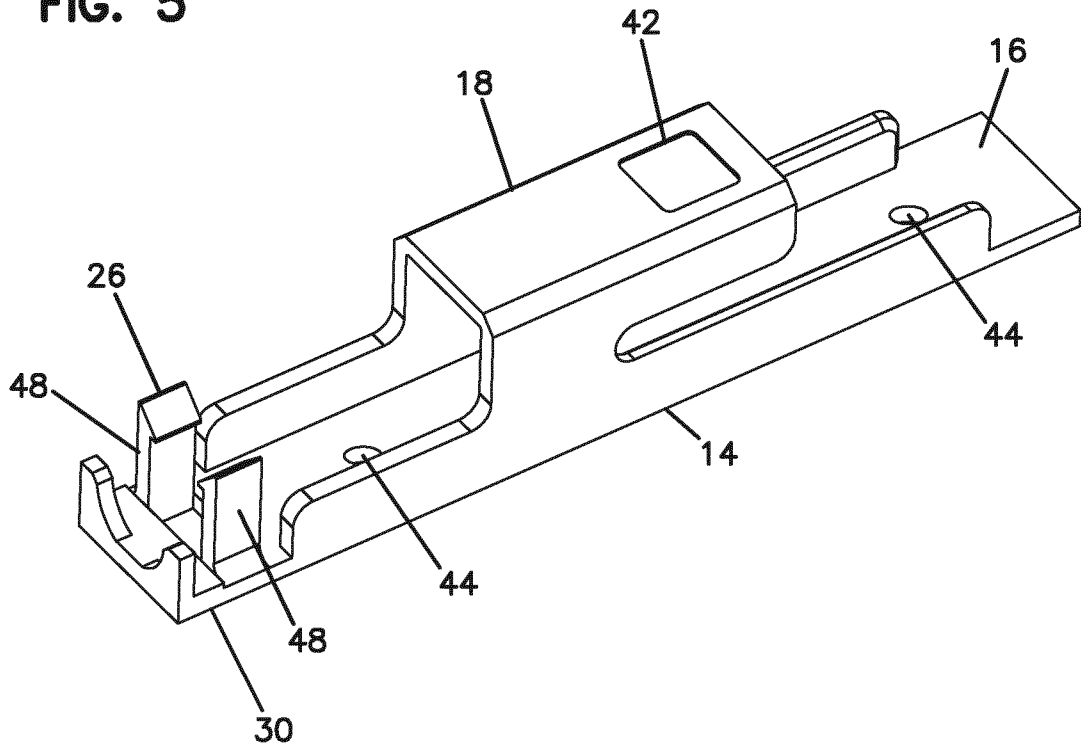
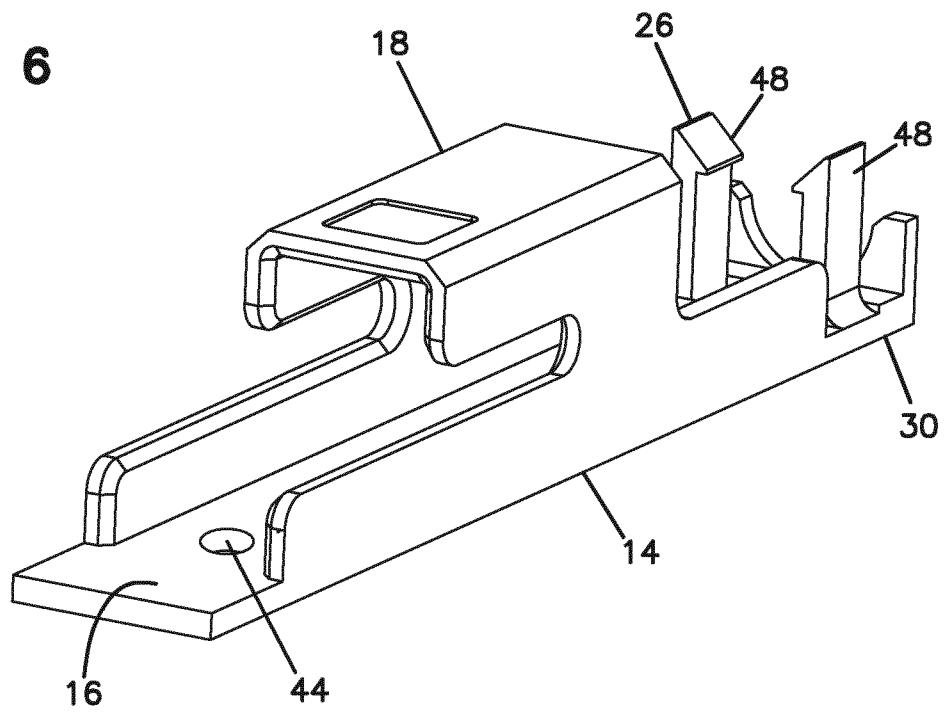

FIG. 6



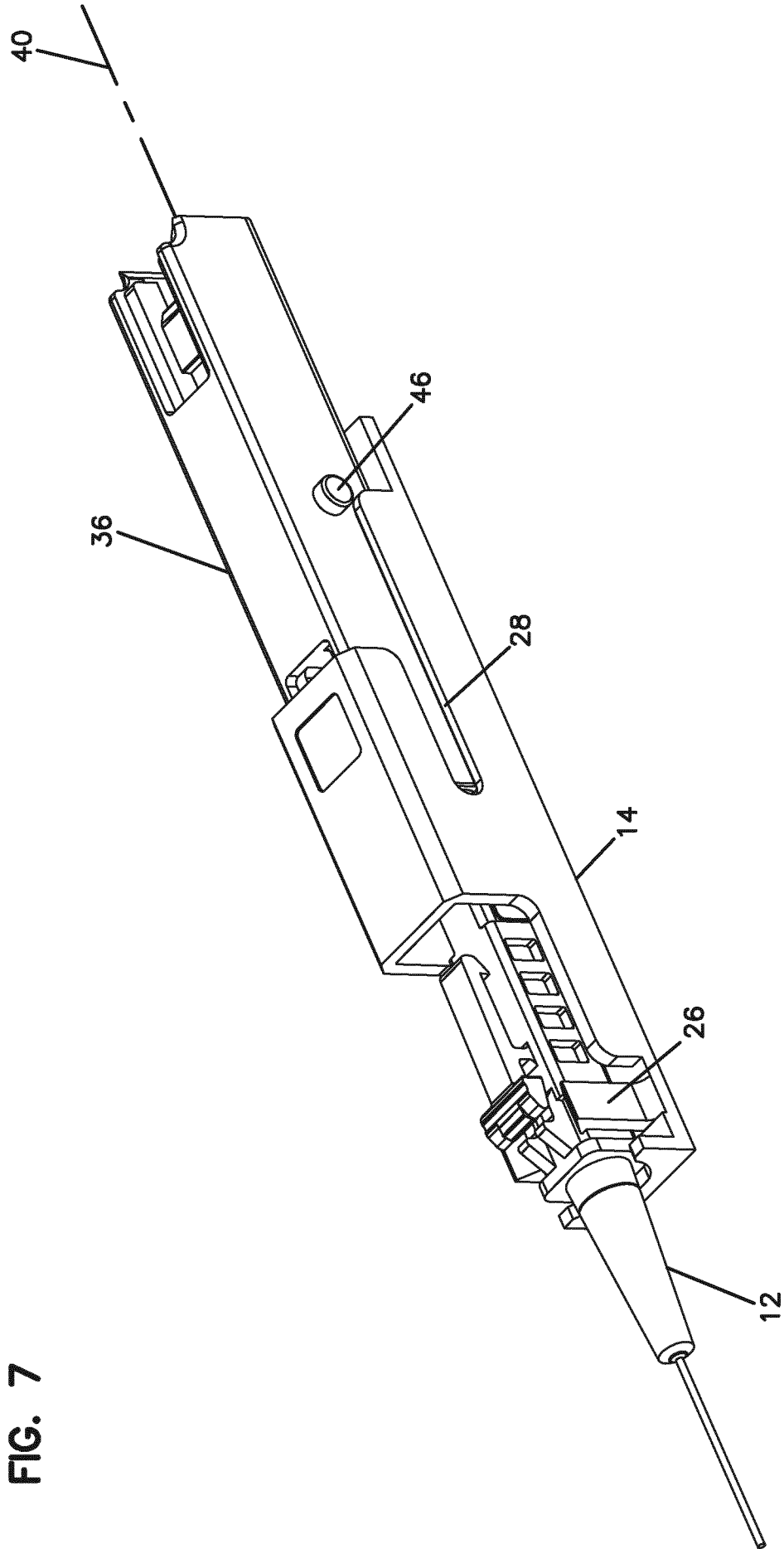
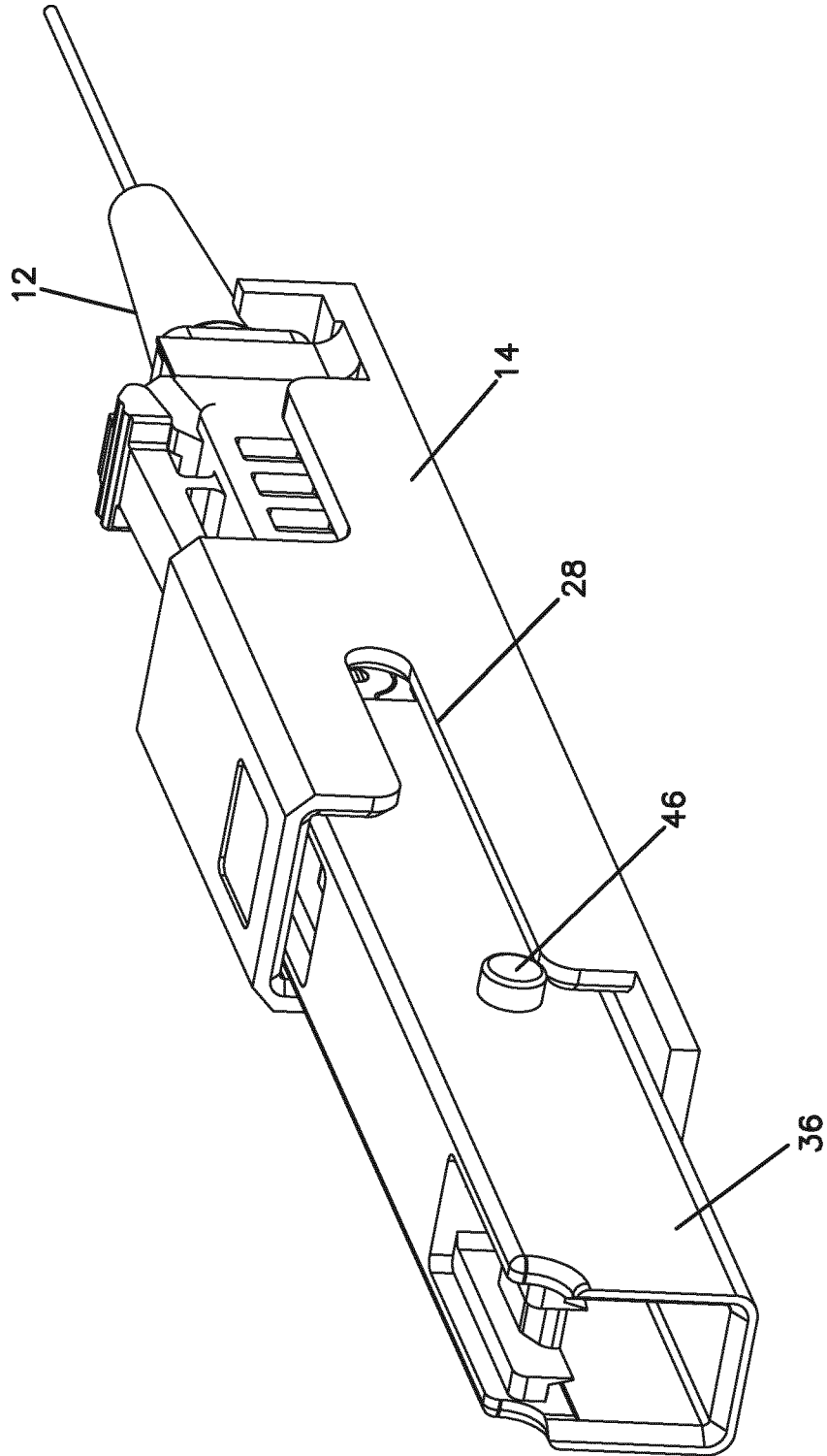

FIG. 7

FIG. 8



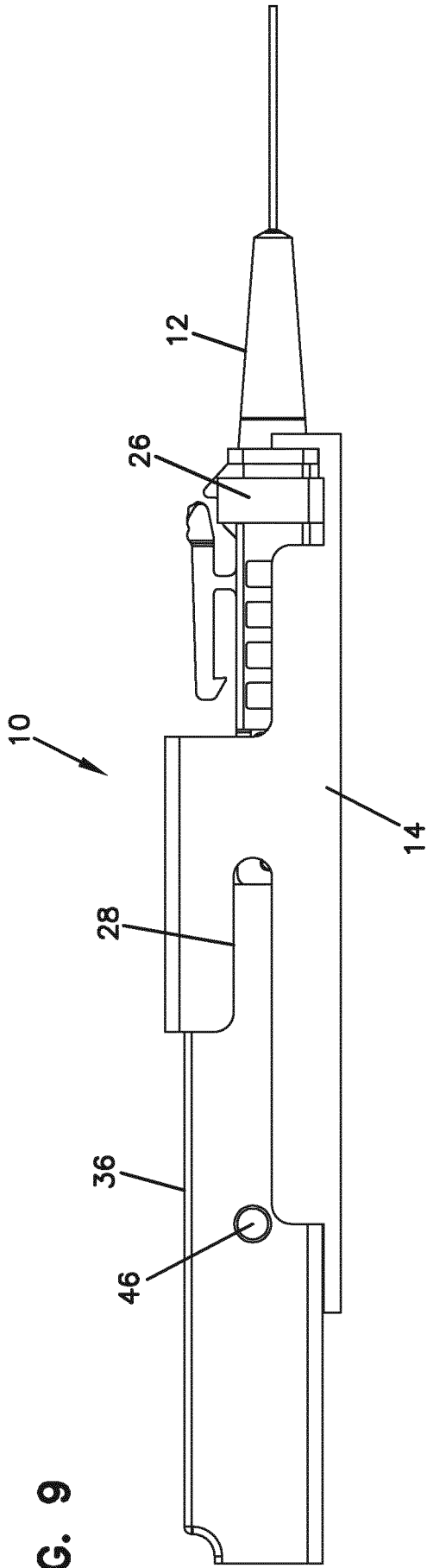
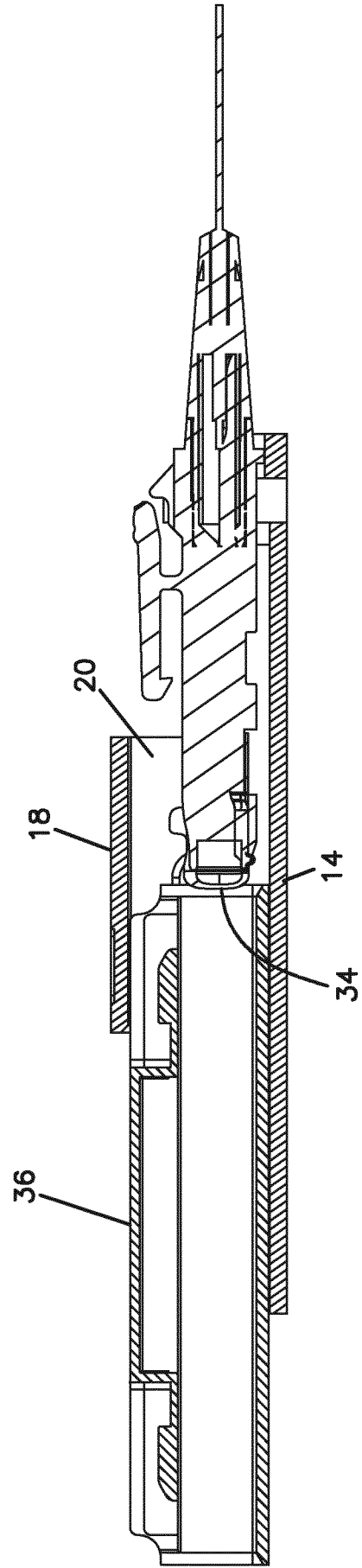

FIG. 10



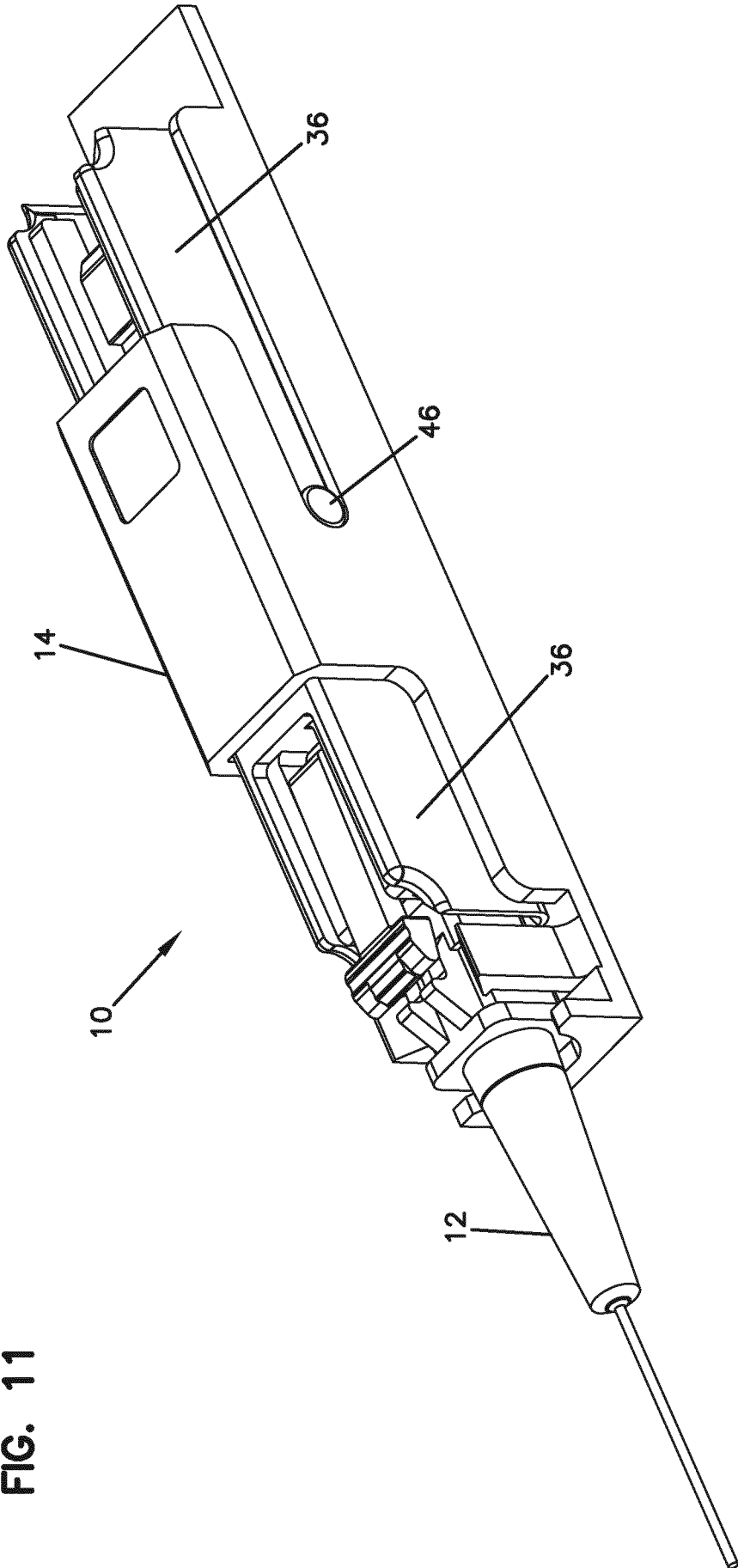

FIG. 11

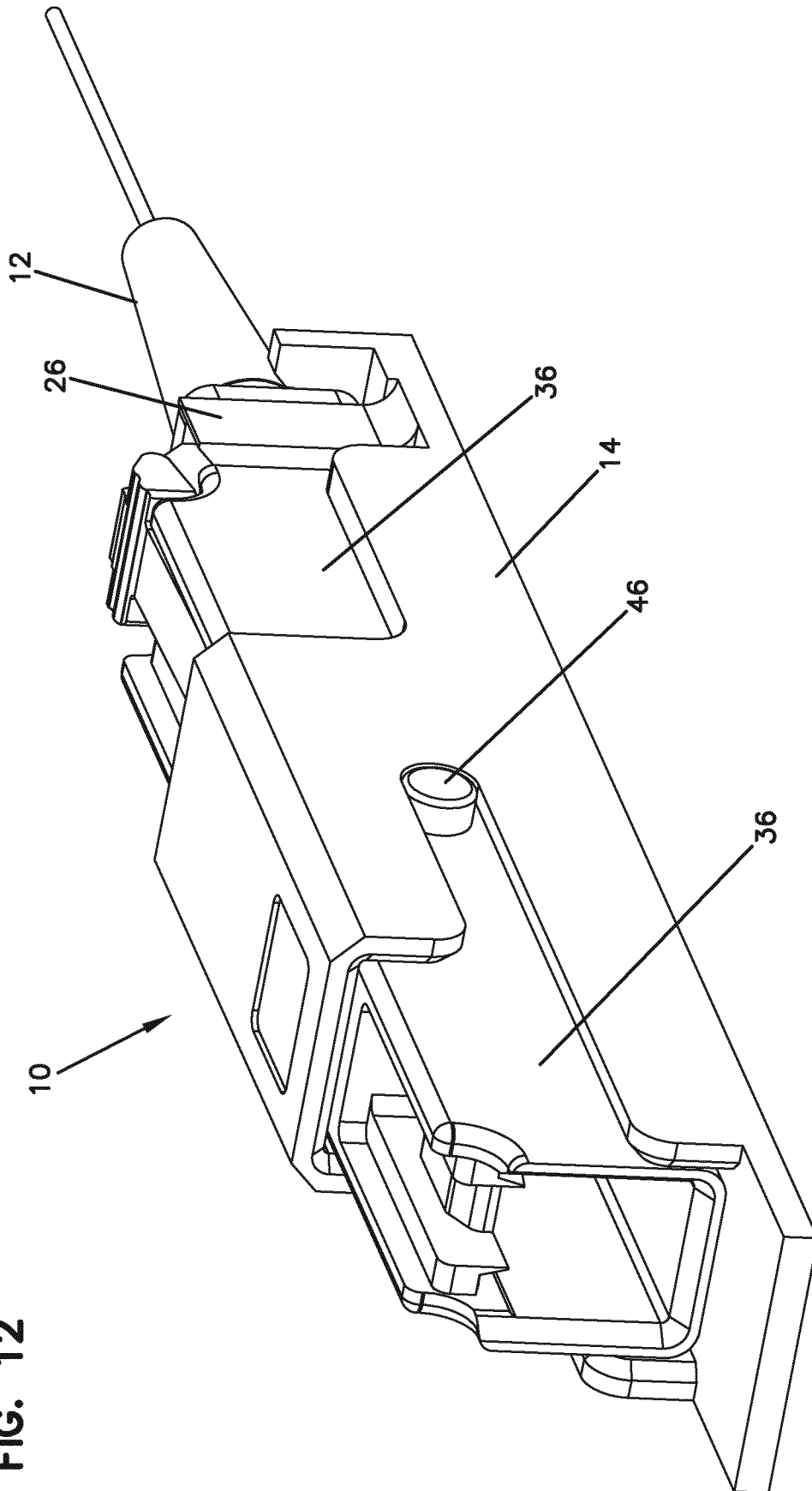
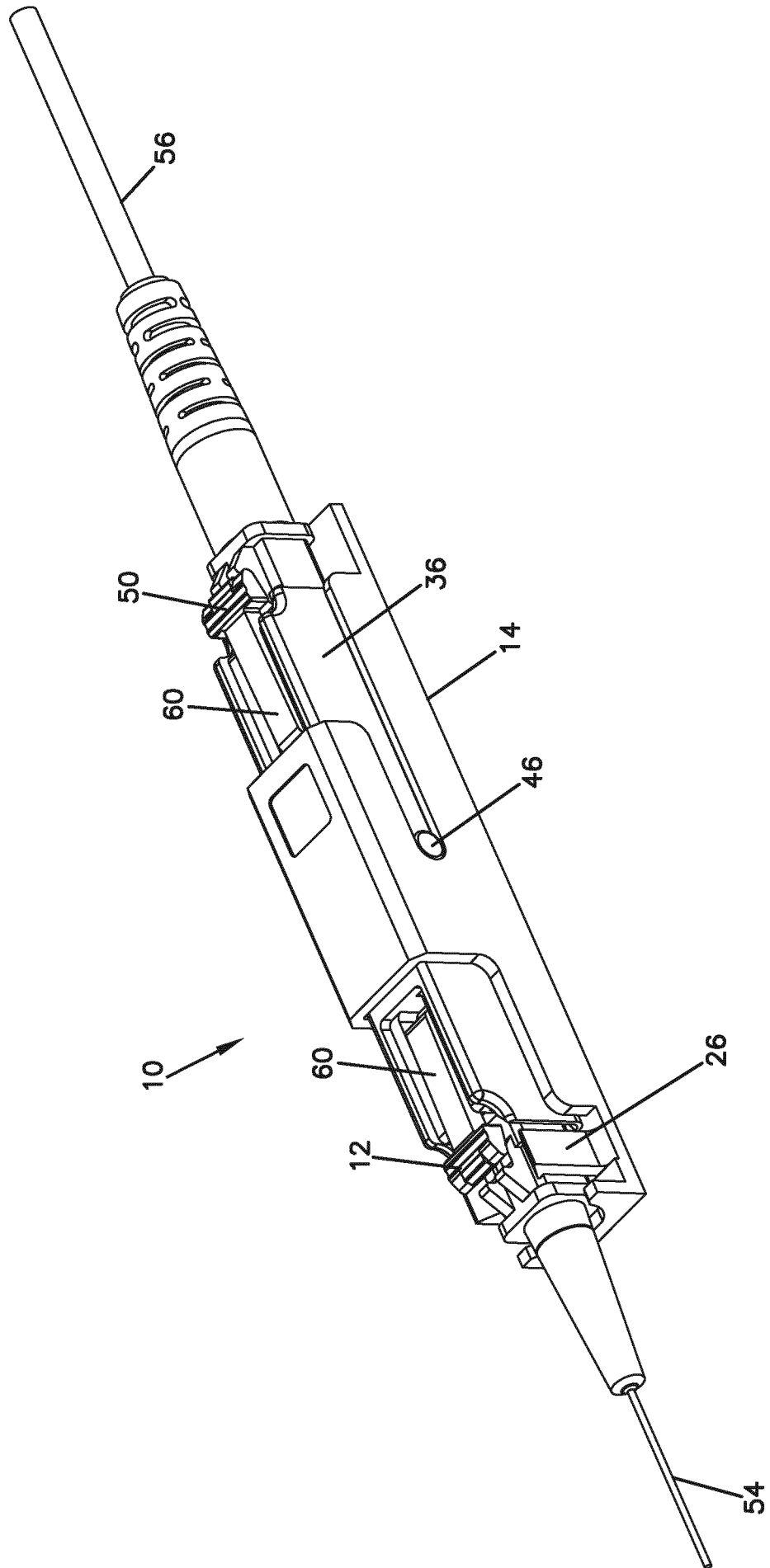

FIG. 12

FIG. 13



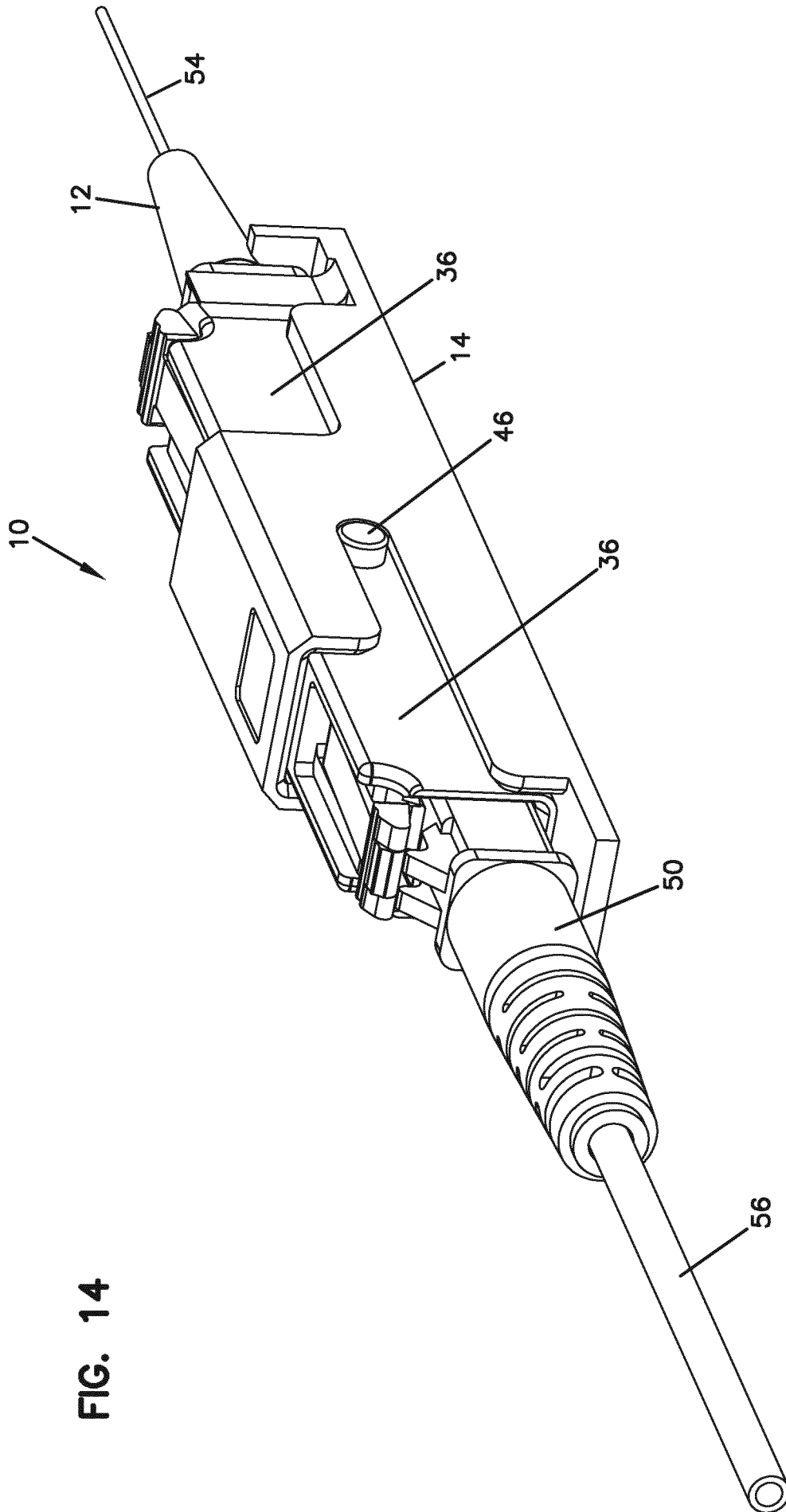

FIG. 14

FIG. 15

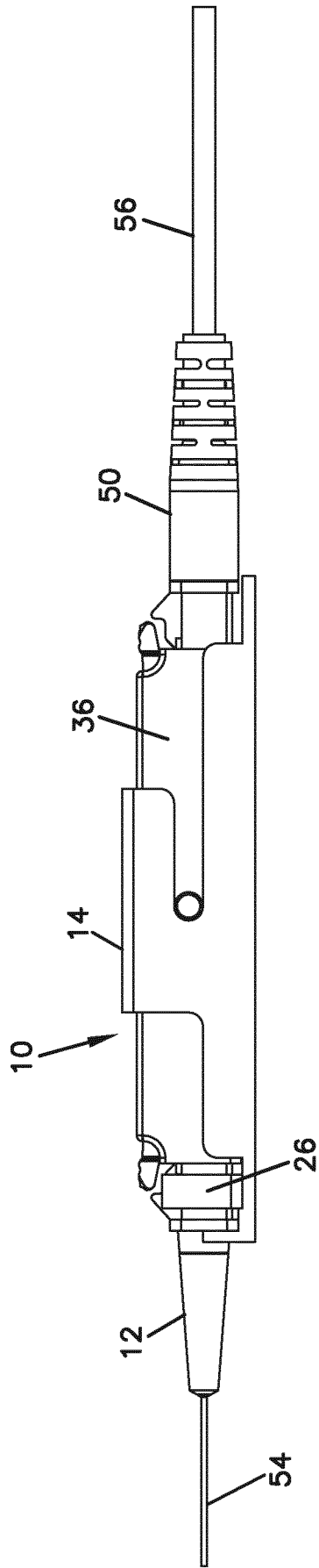
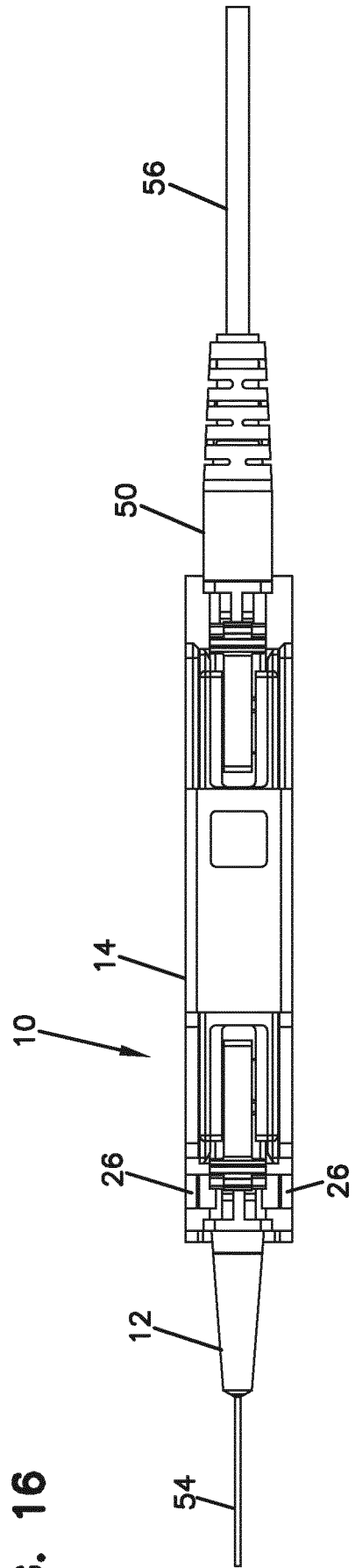
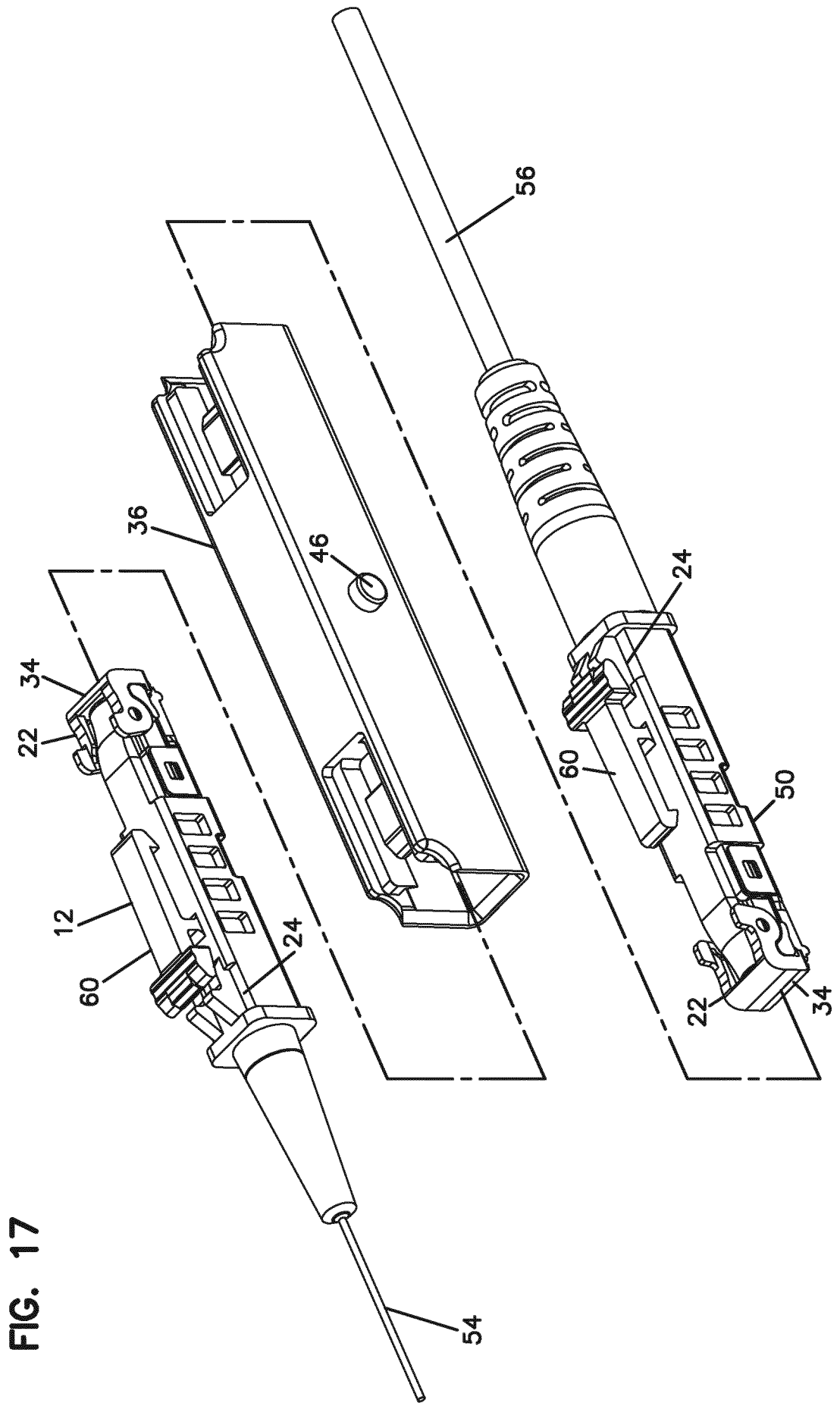

FIG. 16





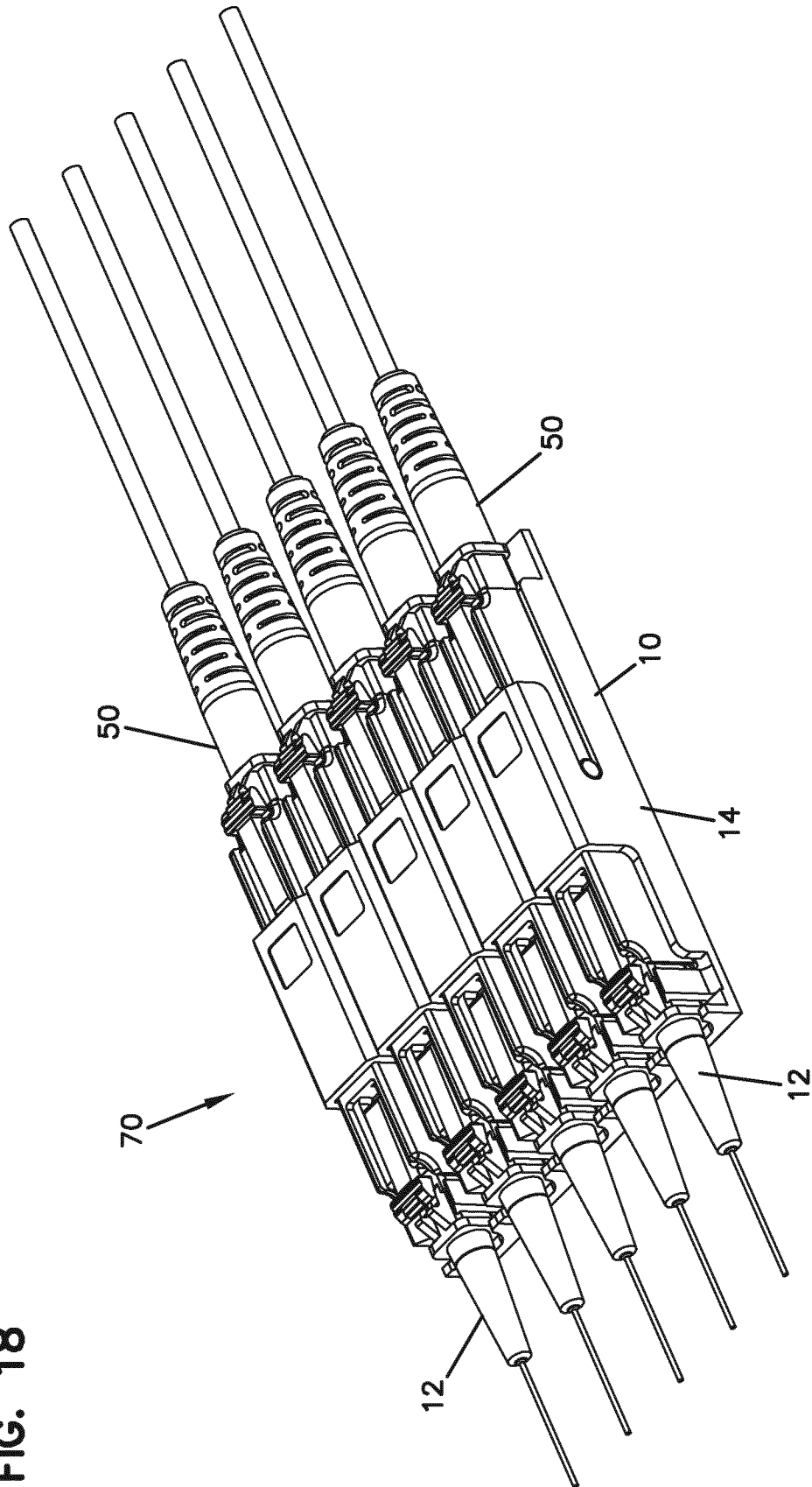

FIG. 18

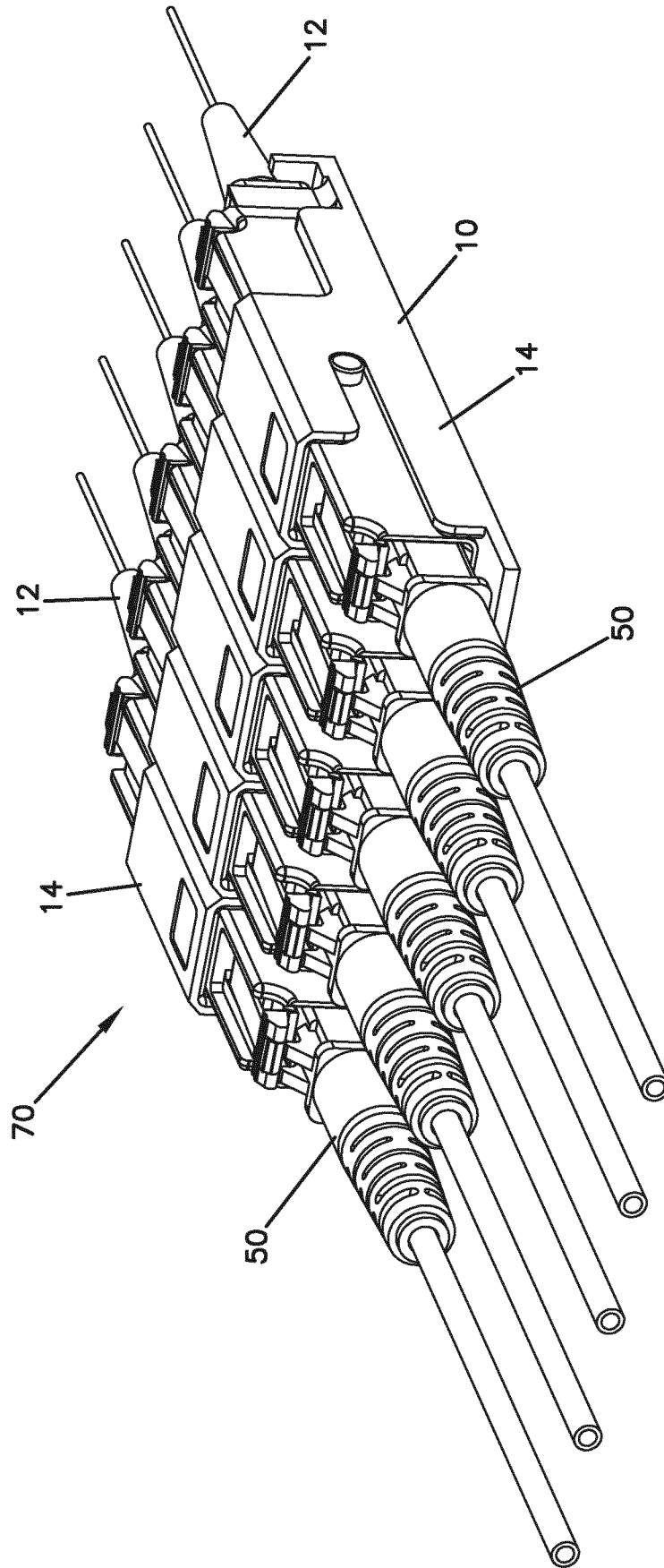

FIG. 19

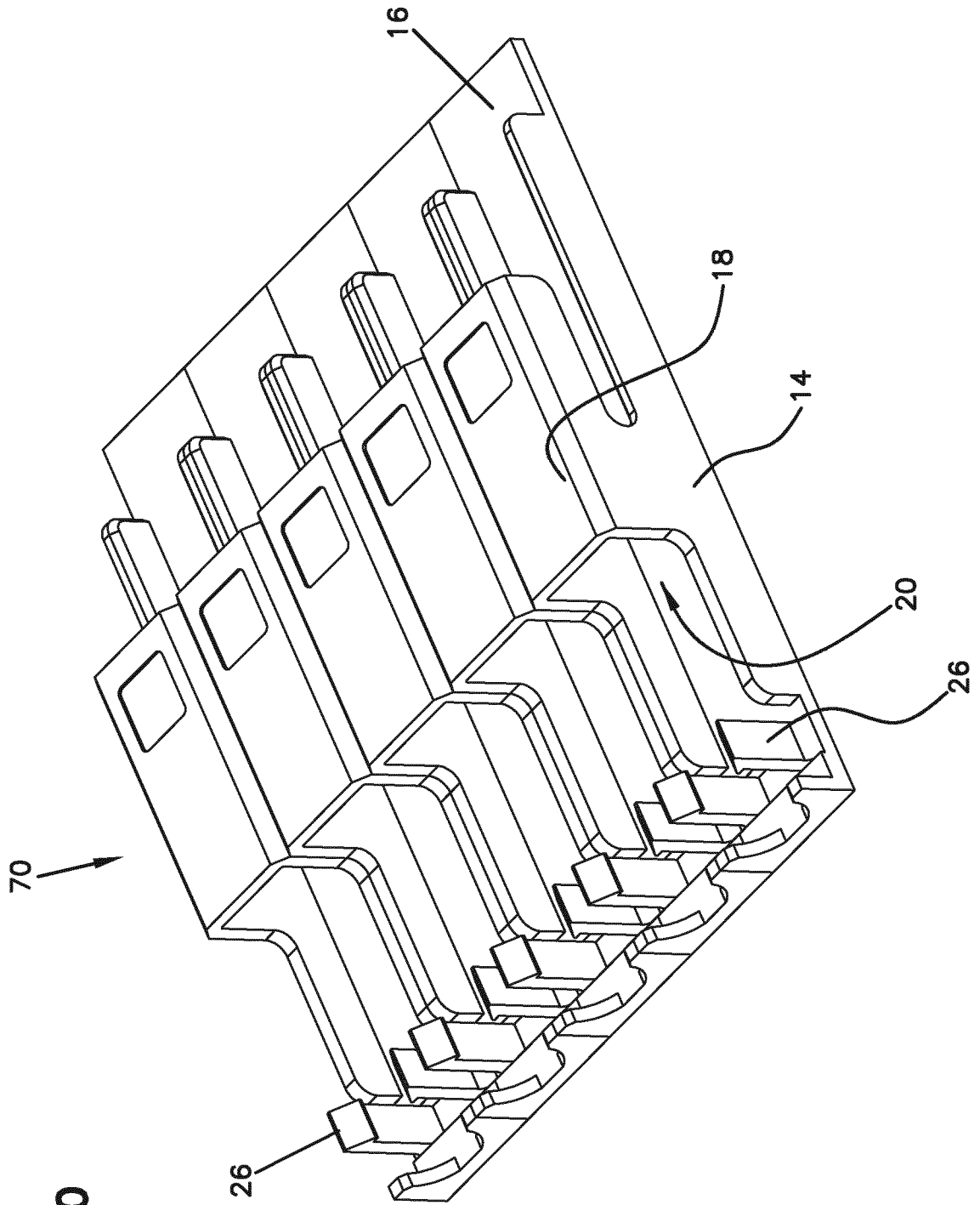

FIG. 20

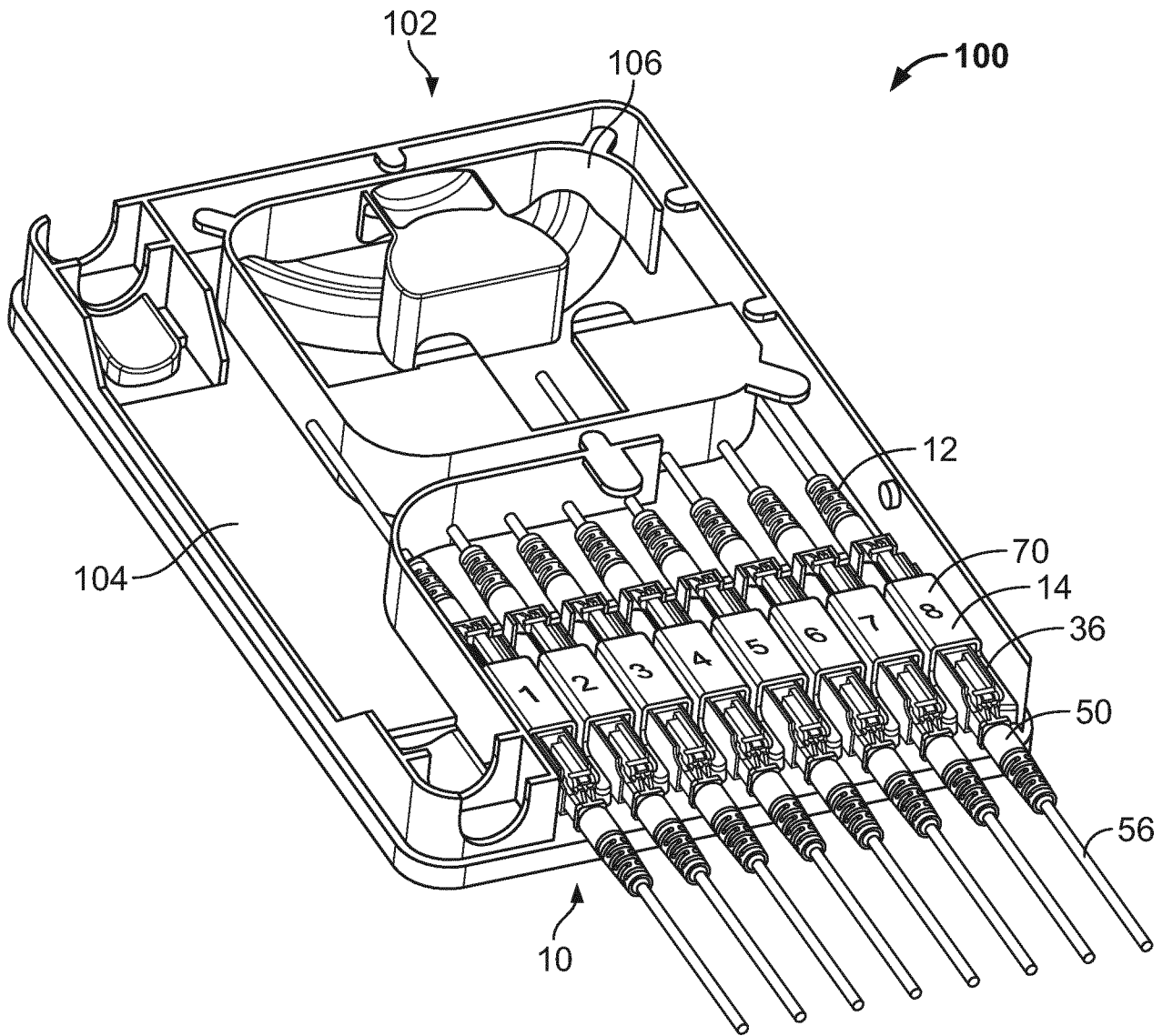

FIG. 21

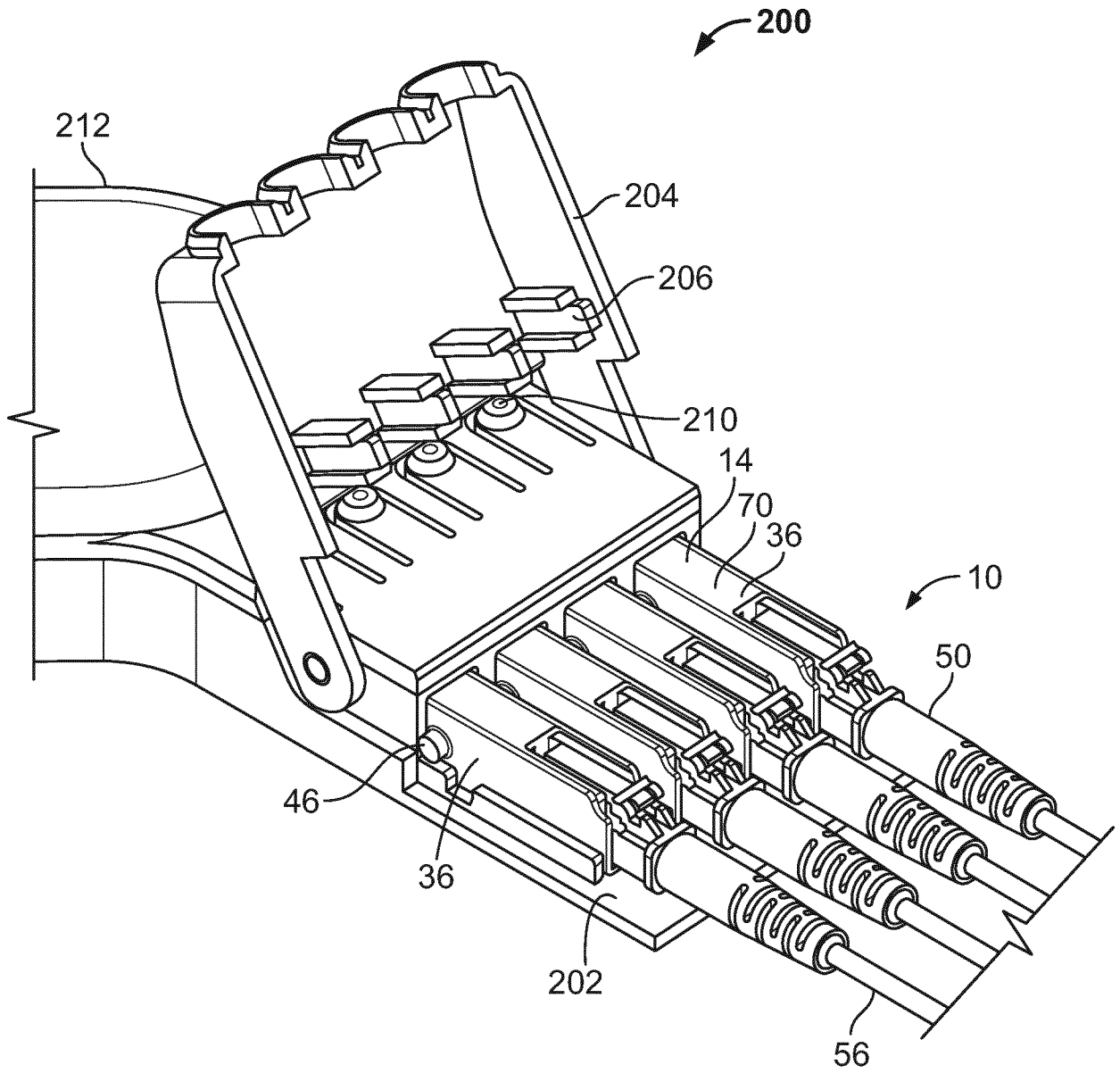

FIG. 22

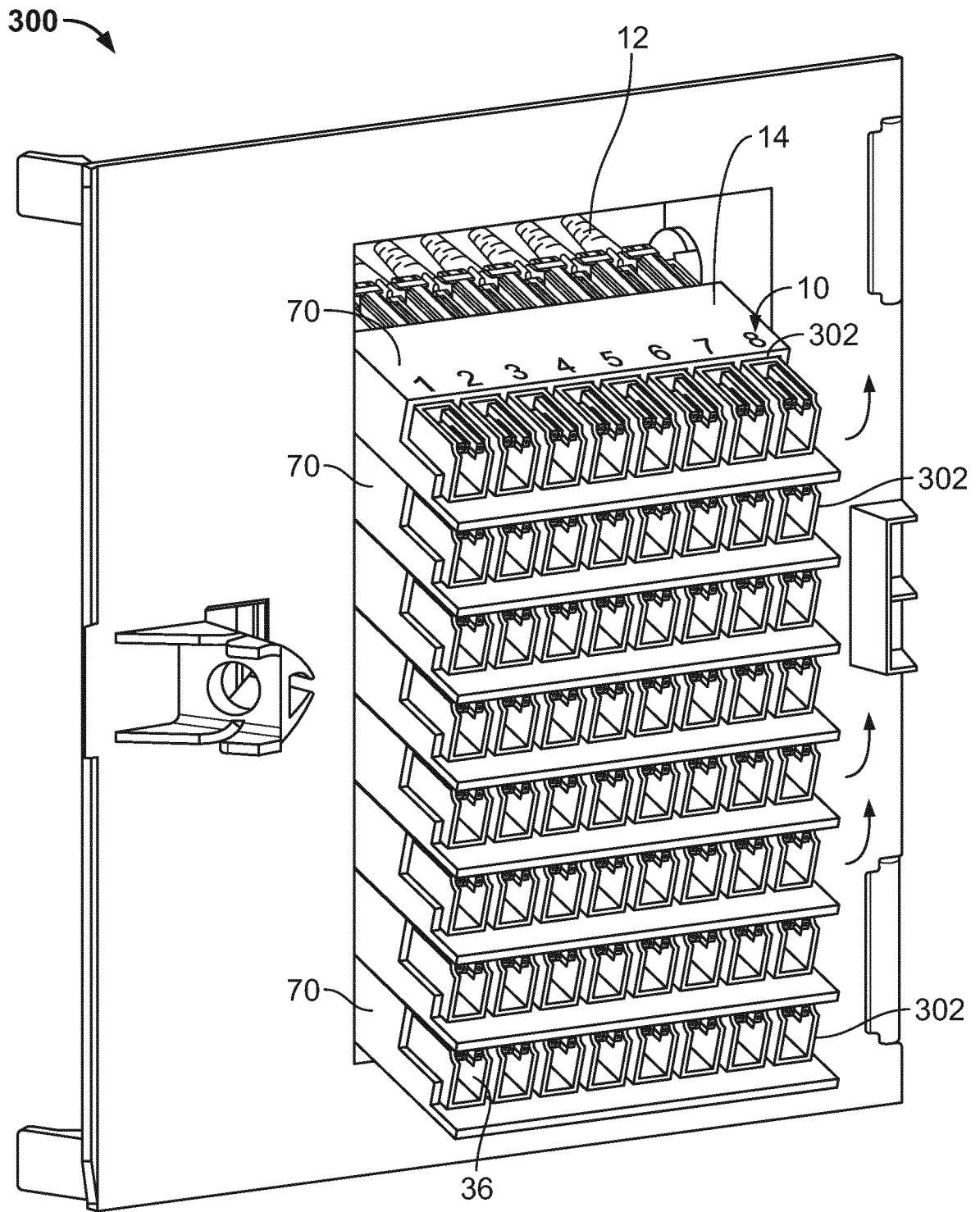

FIG. 23

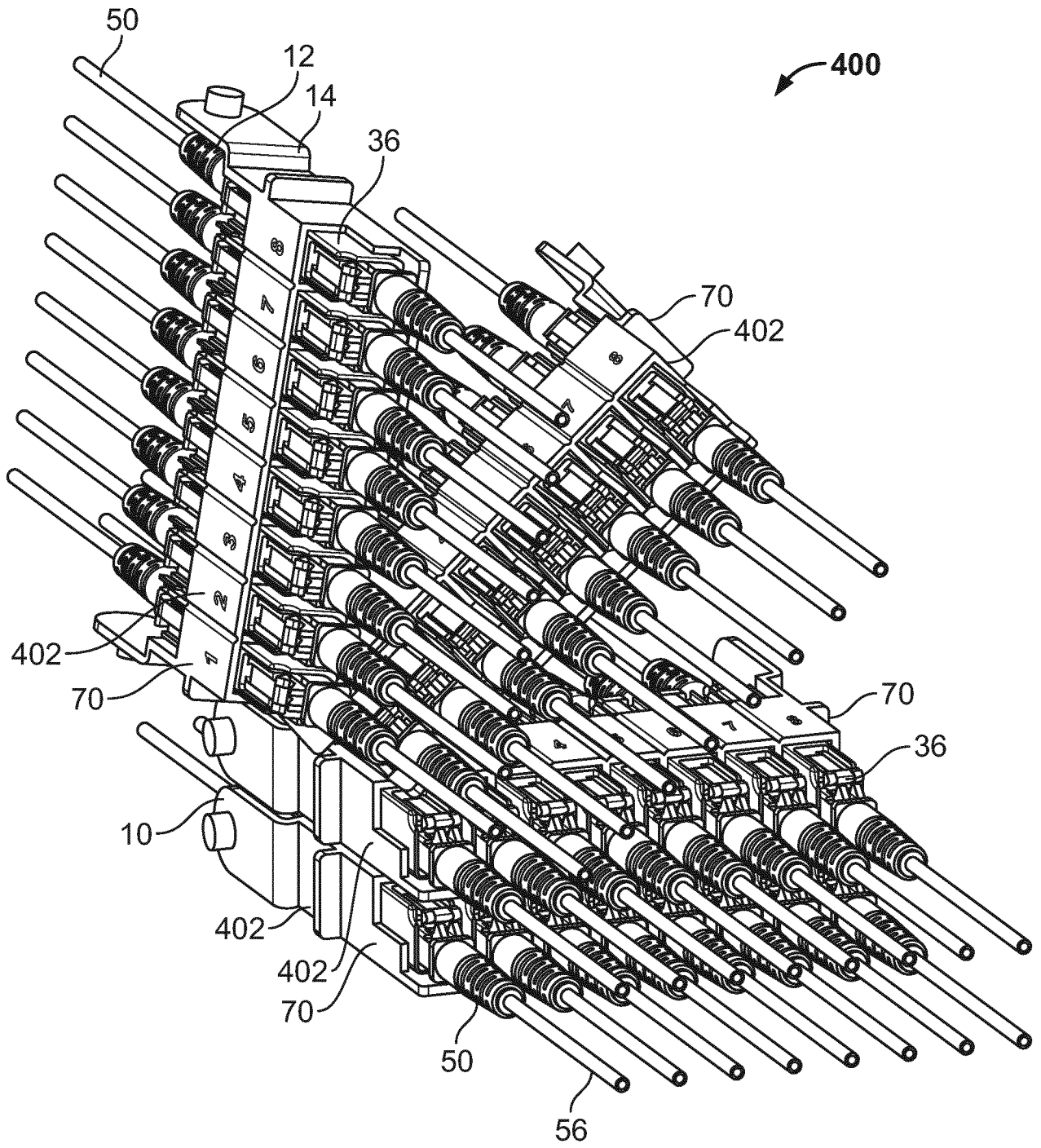

FIG. 24

INTERNATIONAL SEARCH REPORT

International application No
PCT/EP2014/051706

A. CLASSIFICATION OF SUBJECT MATTER
INV. G02B6/38
ADD.

According to International Patent Classification (IPC) or to both national classification and IPC

B. FIELDS SEARCHED
Minimum documentation searched (classification system followed by classification symbols)
G02B

Documentation searched other than minimum documentation to the extent that such documents are included in the fields searched

Electronic data base consulted during the international search (name of data base and, where practicable, search terms used)
EPO-Internal, WPI Data

C. DOCUMENTS CONSIDERED TO BE RELEVANT

Category*	Citation of document, with indication, where appropriate, of the relevant passages	Relevant to claim No.
X	WO 2009/023673 A2 (ILLUM TECHNOLOGIES INC [US]; MARGOLIN MARK [US]; BUNIN GREGORY [US]) 19 February 2009 (2009-02-19)	1,4-15
A	figure 1 figure 4 -----	2,3

Further documents are listed in the continuation of Box C.

See patent family annex.

* Special categories of cited documents :

- "A" document defining the general state of the art which is not considered to be of particular relevance
- "E" earlier application or patent but published on or after the international filing date
- "L" document which may throw doubts on priority claim(s) or which is cited to establish the publication date of another citation or other special reason (as specified)
- "O" document referring to an oral disclosure, use, exhibition or other means
- "P" document published prior to the international filing date but later than the priority date claimed

- "T" later document published after the international filing date or priority date and not in conflict with the application but cited to understand the principle or theory underlying the invention
- "X" document of particular relevance; the claimed invention cannot be considered novel or cannot be considered to involve an inventive step when the document is taken alone
- "Y" document of particular relevance; the claimed invention cannot be considered to involve an inventive step when the document is combined with one or more other such documents, such combination being obvious to a person skilled in the art
- "&" document member of the same patent family

Date of the actual completion of the international search

13 March 2014

Date of mailing of the international search report

21/03/2014

Name and mailing address of the ISA/
European Patent Office, P.B. 5818 Patentlaan 2
NL - 2280 HV Rijswijk
Tel. (+31-70) 340-2040,
Fax: (+31-70) 340-3016

Authorized officer

Orignac, Xavier

INTERNATIONAL SEARCH REPORT

Information on patent family members

International application No

PCT/EP2014/051706

Patent document cited in search report	Publication date	Patent family member(s)	Publication date
WO 2009023673 A2	19-02-2009	EP 2183626 A2	12-05-2010
		US 2009046981 A1	19-02-2009
		WO 2009023673 A2	19-02-2009
