



(12) **DEMANDE DE BREVET CANADIEN
CANADIAN PATENT APPLICATION**

(13) **A1**

(86) Date de dépôt PCT/PCT Filing Date: 2020/07/24
 (87) Date publication PCT/PCT Publication Date: 2021/02/04
 (85) Entrée phase nationale/National Entry: 2021/12/17
 (86) N° demande PCT/PCT Application No.: FI 2020/050504
 (87) N° publication PCT/PCT Publication No.: 2021/019129
 (30) Priorité/Priority: 2019/07/29 (FI20195653)

(51) Cl.Int./Int.Cl. *B30B 1/32* (2006.01),
F15B 11/036 (2006.01)
 (71) Demandeur/Applicant:
VAHTERUS OY, FI
 (72) Inventeur/Inventor:
PITKANEN, PAAVO, FI
 (74) Agent: ROBIC

(54) Titre : ENSEMBLE PISTON-CYLINDRE DE PRESSE HYDRAULIQUE
 (54) Title: PISTON-CYLINDER ASSEMBLY OF A HYDRAULIC PRESS

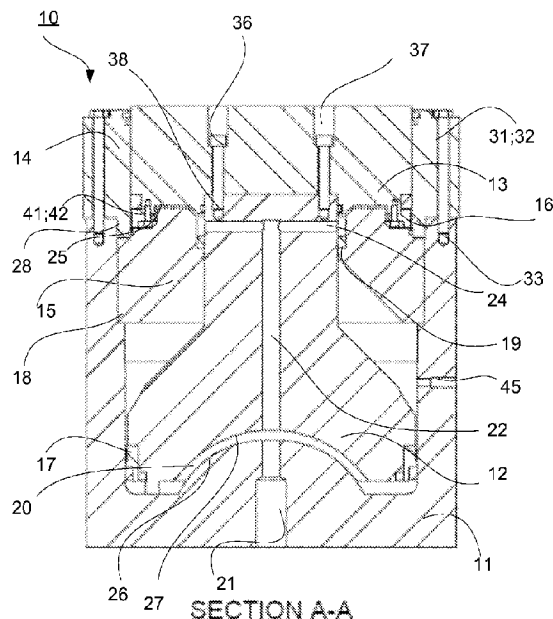

Fig. 1B

(57) **Abrégé/Abstract:**

The invention relates to a piston-cylinder assembly (10) of a hydraulic press, which comprises a basic cylinder (11) and a first and second piston (12, 13). A ring cylinder (14) is formed above the basic cylinder as a continuation of the cylinder structure. The first piston (12) is located inside the basic cylinder (11) in the bottom part of the basic cylinder (11) and the second piston (13) is located above the first piston (12) in the top part of the cylinder structure. The piston-cylinder assembly (10) has a first hydraulic fluid space (20) below the first piston (12) and a second hydraulic fluid space (25) below the second piston (13) and the piston-cylinder assembly comprises a unified hydraulic fluid channel (21, 22, 24) in flow connection to the first hydraulic fluid space (20) in order to provide a pressure effect in the first piston (12) and to the second hydraulic fluid space (25) in order to provide a pressure effect in the second piston (13).

(12) INTERNATIONAL APPLICATION PUBLISHED UNDER THE PATENT COOPERATION TREATY (PCT)

(19) World Intellectual Property
Organization
International Bureau

(43) International Publication Date
04 February 2021 (04.02.2021)



(10) International Publication Number
WO 2021/019129 A1

(51) International Patent Classification:

F15B 11/036 (2006.01) *B30B 1/32* (2006.01)

(21) International Application Number:

PCT/FI2020/050504

(22) International Filing Date:

24 July 2020 (24.07.2020)

(25) Filing Language:

Finnish

(26) Publication Language:

English

(30) Priority Data:

20195653 29 July 2019 (29.07.2019) FI

(71) Applicant: **VAHTERUS OY** [FI/FI]; Pruukintie 7, 23600 Kalanti (FI).

(72) Inventor: **PITKÄNEN, Paavo**; Mustikkapolku 13, 23500 Uusikaupunki (FI).

(74) Agent: **BERGGREN OY**; PO Box 99, 20521 Turku (FI).

(81) Designated States (unless otherwise indicated, for every kind of national protection available): AE, AG, AL, AM, AO, AT, AU, AZ, BA, BB, BG, BH, BN, BR, BW, BY, BZ, CA, CH, CL, CN, CO, CR, CU, CZ, DE, DJ, DK, DM, DO, DZ, EC, EE, EG, ES, FI, GB, GD, GE, GH, GM, GT, HN, HR, HU, ID, IL, IN, IR, IS, IT, JO, JP, KE, KG, KH, KN, KP, KR, KW, KZ, LA, LC, LK, LR, LS, LU, LY, MA, MD, ME, MG, MK, MN, MW, MX, MY, MZ, NA, NG, NI, NO,

NZ, OM, PA, PE, PG, PH, PL, PT, QA, RO, RS, RU, RW, SA, SC, SD, SE, SG, SK, SL, ST, SV, SY, TH, TJ, TM, TN, TR, TT, TZ, UA, UG, US, UZ, VC, VN, WS, ZA, ZM, ZW.

(84) Designated States (unless otherwise indicated, for every kind of regional protection available): ARIPO (BW, GH, GM, KE, LR, LS, MW, MZ, NA, RW, SD, SL, ST, SZ, TZ, UG, ZM, ZW), Eurasian (AM, AZ, BY, KG, KZ, RU, TJ, TM), European (AL, AT, BE, BG, CH, CY, CZ, DE, DK, EE, ES, FI, FR, GB, GR, HR, HU, IE, IS, IT, LT, LU, LV, MC, MK, MT, NL, NO, PL, PT, RO, RS, SE, SI, SK, SM, TR), OAPI (BF, BJ, CF, CG, CI, CM, GA, GN, GQ, GW, KM, ML, MR, NE, SN, TD, TG).

Published:

— with international search report (Art. 21(3))

(54) Title: PISTON-CYLINDER ASSEMBLY OF A HYDRAULIC PRESS

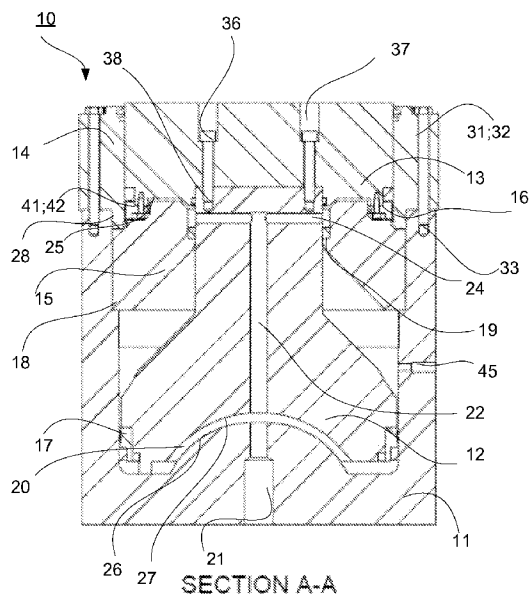

Fig. 1B

(57) Abstract: The invention relates to a piston-cylinder assembly (10) of a hydraulic press, which comprises a basic cylinder (11) and a first and second piston (12, 13). A ring cylinder (14) is formed above the basic cylinder as a continuation of the cylinder structure. The first piston (12) is located inside the basic cylinder (11) in the bottom part of the basic cylinder (11) and the second piston (13) is located above the first piston (12) in the top part of the cylinder structure. The piston-cylinder assembly (10) has a first hydraulic fluid space (20) below the first piston (12) and a second hydraulic fluid space (25) below the second piston (13) and the piston-cylinder assembly comprises a unified hydraulic fluid channel (21, 22, 24) in flow connection to the first hydraulic fluid space (20) in order to provide a pressure effect in the first piston (12) and to the second hydraulic fluid space (25) in order to provide a pressure effect in the second piston (13).



WO 2021/019129 A1

Piston-cylinder assembly of a hydraulic press

Target of the invention

- 5 The invention relates to a piston-cylinder assembly of a hydraulic press. More particularly, the invention relates to a piston-cylinder assembly of a hydraulic press according to the preamble of the independent claim.

Background of the invention

10

Hydraulic forming is used for forming plates or other pieces via force achieved by static fluid pressure in a hydraulic press. In the hydraulic press the force achieved via the piston-cylinder assembly is directed onto the piece to be formed in order to achieve a desired forming effect. The operation of the hydraulic press is based on Pascal's law, according to which external pressure spreads evenly all over a fluid and thus the force achieved in the hydraulic press is the pressure of the hydraulic fluid multiplied by the piston's surface area.

15

Publication FR2290970A1 shows an assembly for a stamping tool, where two hydraulic pistons are used, in which assembly the hydraulic fluid is brought into the piston-cylinder assembly from the end and the side, i.e. through two different hydraulic fluid channels.

20

Publication CN2845947Y shows an assembly for forming metal, where two hydraulic pistons are used, in which assembly the hydraulic fluid is brought in through two different hydraulic fluid channels.

25

Publication EP0561074A1 shows a cylinder operable with a working fluid, comprising a cylinder unit comprising a plurality of cylinder bodies and a partition member between a first cylinder body and a second cylinder body to define a plurality of cylinder chambers arranged in series in an axial direction, each one of said plurality of cylinder bodies containing one piston having an acting side and an opposite, back side, in which seals are provided between the partition member and the first cylinder body and second cylinder body.

30

Publication US2956549A shows a dual piston cylinder, comprising a cylinder member having a closed end, a sleeve member disposed within the open end of said cylinder and having a transverse annular wall provided at one end thereof and dividing said cylinder into spaced chambers, a piston shaft disposed within said cylinder and extended through said wall, piston heads secured to said shaft in each of said chambers, fluid passage means formed centrally through said piston shaft and in open communication with each of said chambers on similar sides of said piston heads, first fluid inlet means disposed in the closed end of said cylinder and communicating directly with the adjacent face of one of said piston heads and communicating with the corresponding face of a second of said piston heads through said fluid passage.

One problem with piston-cylinder assemblies of hydraulic presses known from prior art is that in order to achieve a sufficient working force, the size of the assembly grows, which further leads to a large space requirement in the press.

One disadvantage with piston-cylinder assemblies of hydraulic presses known from prior art is that when using two pistons for increasing force, the channel structure for the hydraulic fluid becomes complicated and thus also the structure of the assembly itself becomes complicated and difficult to control.

The object of the invention is to achieve an improved piston-cylinder assembly of a hydraulic press, where problems and disadvantages of solutions known from prior art have been eliminated or at least minimized.

One particular object of the invention is to create a piston-cylinder assembly of a hydraulic press, where problems and disadvantages of solutions known from prior art, particularly related to the large size and space requirement of the assembly in the press, are eliminated or at least minimized.

Another particular object of the invention is to create a piston-cylinder assembly of a hydraulic press, where problems and disadvantages of solutions known from prior art, particularly related to the complicated channel structure for hydraulic fluid in applications using two pistons, are eliminated or at least minimized.

Summary of the invention

5 In order to obtain the objects presented above and later on, the piston-cylinder assembly of a hydraulic press according to the invention is mainly characterized in what is presented in the characterizing part of the independent claim. Advantageous additional characteristic features are defined in the dependent claims.

10 The piston-cylinder assembly of a hydraulic press according to the invention comprises a basic cylinder and a first and second piston, where a ring cylinder has been attached above the basic cylinder as a continuation of the cylinder structure, the first piston is located inside the basic cylinder in the bottom part of the basic cylinder and the second piston is located above the first piston in
15 the top part of the cylinder structure, where the piston-cylinder assembly has a first hydraulic fluid space below the first piston and a second hydraulic fluid space below the second piston and the piston-cylinder assembly comprises a unified hydraulic fluid channel in flow connection to the first hydraulic fluid space in order to provide a pressure effect in the first piston and to the second
20 hydraulic fluid space in order to provide a pressure effect in the second piston.

According to an advantageous additional characteristic feature of the invention, the hydraulic fluid channel comprises a first hydraulic fluid channel section, which is located to run through the bottom of the basic cylinder, a
25 second hydraulic fluid channel section, which is located to run through the first piston, and transverse third hydraulic fluid channel sections, which continue radially from the second hydraulic fluid channel section.

According to an advantageous additional characteristic feature of the
30 invention, the first hydraulic fluid channel section is in flow connection with the first hydraulic fluid space and the third radial hydraulic fluid channel sections are in flow connection with the second hydraulic fluid space.

According to an advantageous additional characteristic feature of the
35 invention, the cylinder structure of the piston-cylinder assembly comprises a

spacer ring, which is located below the ring cylinder and inside the basic cylinder.

5 According to an advantageous additional characteristic feature of the invention, the first piston and second piston are attached to each other with an attaching arrangement.

10 According to an advantageous additional characteristic of the invention, the basic cylinder and ring cylinder in the cylinder structure of the piston-cylinder assembly are attached to each other with an attaching arrangement.

15 According to an advantageous additional characteristic feature of the invention, the first hydraulic fluid space of the piston-cylinder assembly is sealed against the inner periphery of the basic cylinder with a first sealing ring and the second hydraulic fluid space is sealed against the inner surface of the ring cylinder with a second sealing ring.

20 According to an advantageous additional characteristic feature of the invention, the spacer ring is sealed, via a protrusion, against the outer periphery of the first piston.

25 According to an advantageous additional characteristic of the invention, the space between the first piston and the spacer ring inside the basic cylinder is non-pressurized.

According to an advantageous additional characteristic feature of the invention, the surface areas of the pistons, lower piston and ring piston, of the piston-cylinder assembly are dimensioned so that a desired force is achieved.

30 The invention can be used in connection with many different types of hydraulic presses for forming and piercing metal plates.

35 The invention and its advantageous additional characteristics help to achieve a compact and simultaneously forceful piston-cylinder assembly of a hydraulic press, because the assembly has two pistons in one cylinder, whereby a force

is achieved, where the achieved force is the pressure of the hydraulic fluid multiplied by the surface area of the two pistons.

5 In this description and in the claims the terms below, above, lower part, upper part and so on are not meant to limit as such the use and/or operating position of the piston-cylinder assembly, but the expressions in question are only meant to express the mutual position of the parts and part assemblies. In view of the piston-cylinder assembly for example, the term "below" means the side, from which the hydraulic fluid is brought to the piston-cylinder assembly.

10

Description of the drawings

15 In the following, the invention is described in more detail with reference to the figures of the appended drawing, to the details of which figures the invention is by no means intended to be narrowly limited.

20 Figures 1A-1B show as a schematic view one advantageous example of a piston-cylinder assembly of a hydraulic press. Figure 1A shows the piston-cylinder assembly seen from the outside and figure 1B shows a sectional view A-A of figure 1A.

25 Figures 2A-2B show the example of figures 1A-1B of a piston-cylinder assembly of a hydraulic press as a schematic view, cut along sectional line A-A of figure 1A. In figure 2A the piston is in the lower position and in figure 2B the piston is in the upper position.

30 Figure 3 shows as a schematic view the example of figures 1A-2B of a piston-cylinder assembly as an assembly view.

35 Figures 4A-4B show as a schematic view a second advantageous example of a piston-cylinder assembly of a hydraulic press according to the invention. Figure 4A shows the piston-cylinder assembly seen from the outside and figure 4B shows a sectional view A-A of figure 4A.

Figures 5A-5B show the example of figures 4A-4B of a piston-cylinder assembly of a hydraulic press according to the invention as a schematic view, cut along sectional line A-A of figure 4A. In figure 5A the piston is in the lower position and in figure 5B the piston is in the upper position.

5

Figure 6 shows as a schematic view the example of figures 4A-5B of a piston-cylinder assembly according to the invention as an assembly view.

Detailed description of the invention

10

In the following description, corresponding elements, parts and part assemblies have been indicated with corresponding reference numbers and markings in figures 1A - 6 unless otherwise mentioned, and it should be understood that the examples can be modified for different applications and different situations. From some figures some repeated reference markings may have been left out for the sake of clarity of the figures. In the following description, even though certain features are described in a certain context and application, the features can be applied also in another context and application regardless of if this has been mentioned, and many modifications and variations are thus possible.

15

20

Figures 1A - 3 show as a schematic view one example of a piston-cylinder assembly 10 of a hydraulic press, which comprises a basic cylinder 11 and a ring cylinder 14 attached to its top surface. The piston-cylinder assembly 10 further comprises two pistons 12, 13; a first piston 12, which is located inside the basic cylinder 11, in the lower part of the basic cylinder 11, and a second piston 13, which is located above the first piston 12 and the basic cylinder 11.

25

The first piston 12 and the second piston 13 are attached to each other with an attaching arrangement 36, 37, 38, which comprises screws 36, which run through penetrating holes 37 made in the second piston 13 and attach to attaching holes 38 in the first piston 12.

30

In the cylinder structure of the piston-cylinder assembly 10 the basic cylinder 11 and the ring cylinder 14 are attached to each other with an attaching arrangement 31, 32, 33, which comprises screws 31, which run through penetrating holes 32 made in the ring cylinder 14 and attach to attaching holes

33 in the basic cylinder 11. Thus, the ring cylinder 14 forms a continuing part to the basic cylinder 11.

The cylinder structure 11, 14 of the piston-cylinder assembly 10 also comprises a spacer ring 15, which is located below the ring cylinder 14 and inside the basic cylinder 11. The spacer ring 15 is supported from below on a shoulder 18 made on the inner periphery of the basic cylinder 11 and from above on a protrusion 28 in the ring cylinder 14. The spacer ring 15 is via a protrusion 19 sealed against the outer periphery of the first piston 12, so that hydraulic fluid is not led from the second hydraulic fluid space 25 to the space between the spacer ring 15 and the first piston 12 inside the basic cylinder 11.

The first hydraulic fluid space 20 below the first piston 12 is formed between the lower surface of the piston 12 and the inner lower surface of the basic cylinder 11 and is sealed against the inner periphery of the basic cylinder 11 with a first sealing ring 17. Inside the ring cylinder 14, between the upper surface of the spacer ring 15 and the lower surface of the second piston 13, has been formed a second hydraulic fluid space 25 and it is sealed against the inner surface of the ring cylinder 14 with a second sealing ring 16. The second sealing ring 16 is attached to the second piston 13 with an attaching arrangement 41, 42, which comprises attaching screws 41 running through the sealing ring 16, which screws attach to attaching holes 42 made in the lower surface of the second piston 13.

The pressurized hydraulic fluid is led to the first hydraulic fluid space 20 via the first hydraulic fluid channel section 21 in order to achieve hydraulic pressure directed at the first piston 12. The hydraulic fluid channel 21 is located to run through the bottom of the basic cylinder 11, by its mid axis. The hydraulic fluid is led onwards via the second hydraulic fluid channel section 22, which runs through the first piston 12 by its mid axis and ends in radial, transverse third hydraulic fluid channel sections 24, and via the third hydraulic fluid channels 24 to the second hydraulic fluid space 25 in order to achieve hydraulic pressure directed at the second piston 13. The channel sections 21, 22, 24 thus form a unified hydraulic fluid channel 21, 22, 24 in flow connection to the first hydraulic fluid space 20 and thus in order to achieve a pressure effect in the first piston 12 and to the second hydraulic fluid space 25 and thus in order to achieve a pressure effect in the second piston 13.

The force achievable with the piston-cylinder assembly 10 is thus the pressure of the hydraulic fluid multiplied by the sum of the surface areas of the first and second piston, whereby a great force is achieved without increasing the diameter of the piston-cylinder assembly 10. Thus, the piston-cylinder assembly 10 is compact and its space requirement is small. Additionally, the channel and other structure of the piston-cylinder assembly 10 is simple.

The space between the first piston 12 and the spacer ring 15 is non-pressurized inside the basic cylinder 11 and is thus not for hydraulic fluid, and if hydraulic fluid erupts from a so-called leak alert hole in a channel 45 made in the wall of the basic cylinder 11, it is known that the sealing rings 16, 17 and/or the sealing protrusion 19 and thus the piston-cylinder assembly 10 do not function in a desired manner.

The inside lower surface of the basic cylinder 11 advantageously comprises a ball segment-shaped protrusion protruding inwards around the outlet of the hydraulic fluid channel 21, and correspondingly, the first piston 12 advantageously comprises on its lower surface a corresponding ball segment-shaped recess in order to strengthen the structure of the piston-cylinder assembly 10 and its first hydraulic fluid space 20.

Figures 4A - 6 show as a schematic view a second example of a piston-cylinder assembly 10 of a hydraulic press, which comprises a basic cylinder 11 and a ring cylinder 14 attached to its upper surface, which ring cylinder is via a collar ring 29, which is one piece with the ring cylinder, connected to a spacer ring 15 into the same one piece, whereby a unified ring cylinder assembly 30 is formed. The piston-cylinder assembly 10 further comprises two pistons 12, 13; a first piston 12, which is located inside the basic cylinder 11, in the lower part of the basic cylinder 11, and a second piston 13, which is located above the first piston 12 and the basic cylinder 11.

The first piston 12 and the second piston 13 are attached to each other with an attaching arrangement 36, 37, 38, which comprises screws 36, which run through penetrating holes 37 made in the second piston 13 and attach to attaching holes 38 in the first piston 12.

In the cylinder structure of the piston-cylinder assembly 10 the basic cylinder 11 and the ring cylinder 14 are attached to each other with an attaching arrangement 31, 32, 33, which comprises screws 31, which run through penetrating holes 32 made in the ring cylinder 14 and attach to attaching holes 5 33 in the basic cylinder 11. Thus, the ring cylinder 14 forms a continuing part to the basic cylinder 11.

The ring cylinder assembly 30 of the piston-cylinder assembly 10 comprises the ring cylinder 14 and the spacer ring 15, which is below the ring cylinder 14, which are connected into one piece via the collar ring 29. The outer diameter 10 of the ring cylinder 14 of the ring cylinder assembly 30 is substantially the same as the outer diameter of the basic cylinder 11. Via the indentation achievable via the collar ring 29, the spacer ring 15 of the ring cylinder assembly 30 is set to be located inside the basic cylinder 11. The spacer ring 15 is supported from 15 below on a shoulder made on the inner periphery of the basic cylinder 11. The spacer ring 15 is via a sealing 19 sealed against the outer periphery of the first piston 12, so that hydraulic fluid is not led from the second hydraulic fluid space 25 to the space between the spacer ring 15 and the first piston 12 inside the basic cylinder 11.

The first hydraulic fluid space 20 below the first piston 12 is formed between 20 the lower surface of the piston 12 and the inner lower surface of the basic cylinder 11 and is sealed against the inner periphery of the basic cylinder 11 with a first sealing ring 17. Inside the ring cylinder 14, between the upper surface of the spacer ring 15 and the lower surface of the second piston 13, has been formed a second hydraulic fluid space 25 and it is sealed against the 25 inner surface of the ring cylinder 14 with a second sealing ring 16. The second sealing ring 16 is attached to the second piston 13 with an attaching arrangement 41, 42, which comprises attaching screws 41 running through the sealing ring 16, which screws attach to attaching holes 42 made in the lower surface of the second piston 13.

30 The pressurized hydraulic fluid is led to the first hydraulic fluid space 20 via the first hydraulic fluid channel section 21 in order to achieve hydraulic pressure directed at the first piston 12. The hydraulic fluid channel 21 is located to run through the bottom of the basic cylinder 11, by its mid axis. The hydraulic fluid is led onwards via the second hydraulic fluid channel section 22, which runs

10

through the first piston 12 by its mid axis and ends in radial, transverse third hydraulic fluid channel sections 24, and via the third hydraulic fluid channels 24 to the second hydraulic fluid space 25 in order to achieve hydraulic pressure directed at the second piston 13. The channel sections 21, 22, 24 thus form a
5 unified hydraulic fluid channel 21, 22, 24 in flow connection to the first hydraulic fluid space 20 and thus in order to achieve a pressure effect in the first piston 12 and to the second hydraulic fluid space 25 and thus in order to achieve a pressure effect in the second piston 13.

The force achievable with the piston-cylinder assembly 10 is thus the pressure
10 of the hydraulic fluid multiplied by the sum of the surface areas of the first and second piston, whereby a great force is achieved without increasing the diameter of the piston-cylinder assembly 10. Thus, the piston-cylinder assembly 10 is compact and its space requirement is small. Additionally, the channel and other structure of the piston-cylinder assembly 10 is simple.

15 The space between the first piston 12 and the spacer ring 15 is depressurized inside the basic cylinder 11 and is thus not for hydraulic fluid, and if hydraulic fluid erupts from a so-called leak alert hole in a channel 45 made in the wall of the basic cylinder 11, it is known that the sealing rings 16, 17 and/or the sealing protrusion 19 and thus the piston-cylinder assembly 10 do not function in a
20 desired manner.

The inside lower surface of the basic cylinder 11 advantageously comprises a ball segment-shaped protrusion protruding inwards around the outlet of the hydraulic fluid channel 21, and correspondingly, the first piston 12 advantageously comprises on its lower surface a corresponding ball segment-
25 shaped recess in order to strengthen the structure of the piston-cylinder assembly 10 and its first hydraulic fluid space 20.

The invention has been described above only with reference to one advantageous example of it, to the details of which it is however not meant to narrowly limit the invention, but many modifications and variations are possible
30 within the inventive idea defined by the following claims.

AMENDED SHEET

Claims

1. A piston-cylinder assembly (10) of a hydraulic press, which comprises a basic cylinder (11) and a first and second piston (12, 13), in which a ring cylinder (14) has been formed above the basic cylinder as a continuation of the cylinder structure, the first piston (12) is located inside the basic cylinder (11) in the bottom part of the basic cylinder (11) and the second piston (13) is located above the first piston (12) in the top part of the cylinder structure, the piston-cylinder assembly (10) has a first hydraulic fluid space (20) below the first piston (12) and a second hydraulic fluid space (25) below the second piston (13) and the piston-cylinder assembly comprises a unified hydraulic fluid channel (21, 22, 24) in flow connection to the first hydraulic fluid space (20) in order to provide a pressure effect in the first piston (12) and to the second hydraulic fluid space (25) in order to provide a pressure effect in the second piston (13), which cylinder structure (11, 14) of the piston-cylinder assembly (10) comprises a ring cylinder assembly (30), **characterized in that** the ring cylinder assembly (30) comprises the ring cylinder (14), a spacer ring (15), which is below the ring cylinder (14), and a collar ring (29), that the ring cylinder (14) is via the collar ring (29), which is one piece with the ring cylinder (14), connected to the spacer ring (15) into the same one piece, whereby the ring cylinder assembly (30) is formed unified.
2. The piston-cylinder assembly (10) of a hydraulic press according to claim 1, **characterized in that** the hydraulic fluid channel comprises a first hydraulic fluid channel section (21), which is located to run through the bottom of the basic cylinder (11), a second hydraulic fluid channel section (22), which is located to run through the first piston (12), and transverse third hydraulic fluid channel sections (24), which continue radially from the second hydraulic fluid channel section (22).
3. The piston-cylinder assembly (10) of a hydraulic press according to claim 2, **characterized in that** the first hydraulic fluid channel section (21) is in flow connection to the first hydraulic fluid space (20) and that the third radial hydraulic fluid channel sections are in flow connection to the second hydraulic fluid space (25).

- .
4. The piston-cylinder assembly (10) of a hydraulic press according to any of the preceding claims, **characterized in that** the first piston (12) and the second piston (13) are attached to each other with an attaching arrangement (36, 37, 38).
- 5
5. The piston-cylinder assembly (10) of a hydraulic press according to any of the preceding claims, **characterized in that** the first hydraulic fluid space (20) of the piston-cylinder assembly (10) is sealed against the inner periphery of the basic cylinder (11) with a first sealing ring (17) and the second hydraulic fluid space (25) is sealed against the inner surface of the ring cylinder (14) with a second sealing ring (16).
- 10
6. The piston-cylinder assembly (10) of a hydraulic press according to any of the preceding claims, **characterized in that** the spacer ring (15) is via a protrusion and/or sealing (19) sealed against the outer periphery of the first piston (12).
- 15
7. The piston-cylinder assembly (10) of a hydraulic press according to any of the preceding claims, **characterized in that** the space between the first piston (12) and spacer ring (15) inside the basic cylinder (11) is depressurized.

20

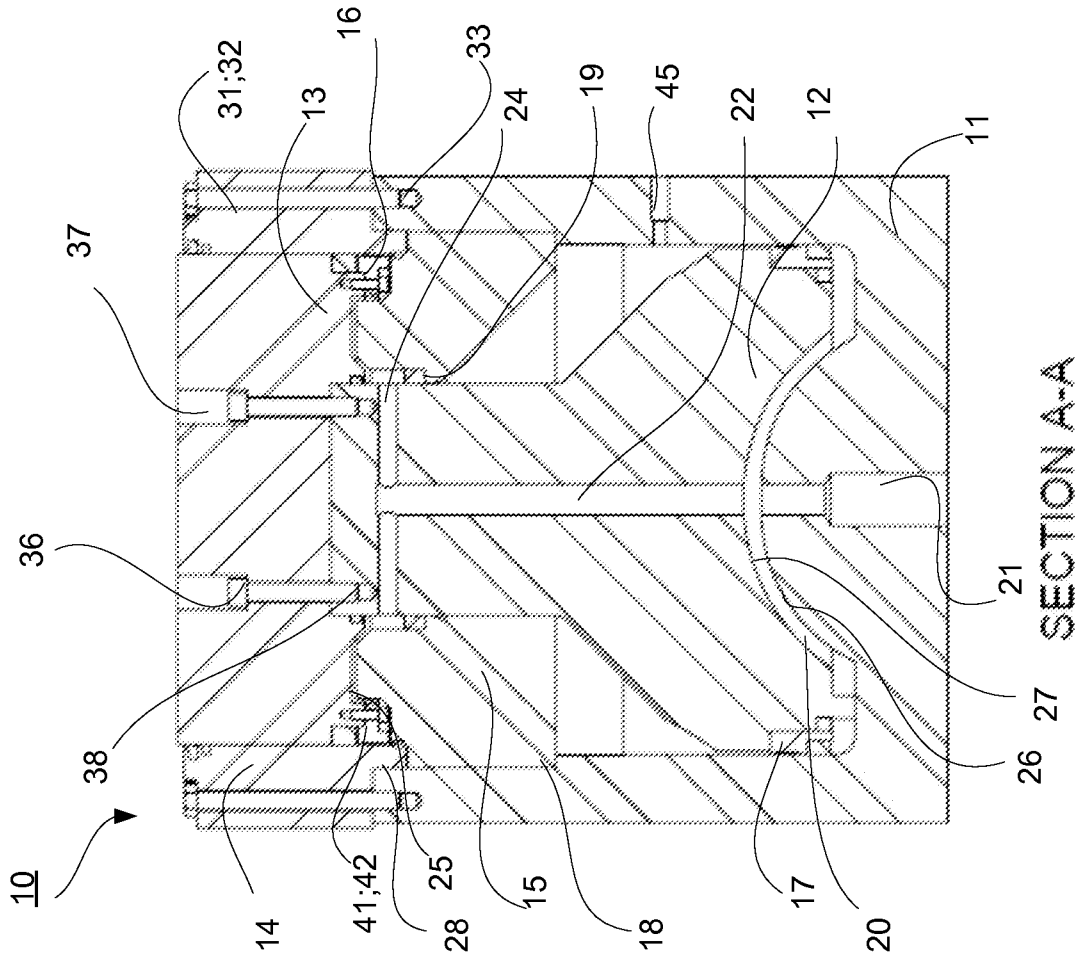

Fig. 1A

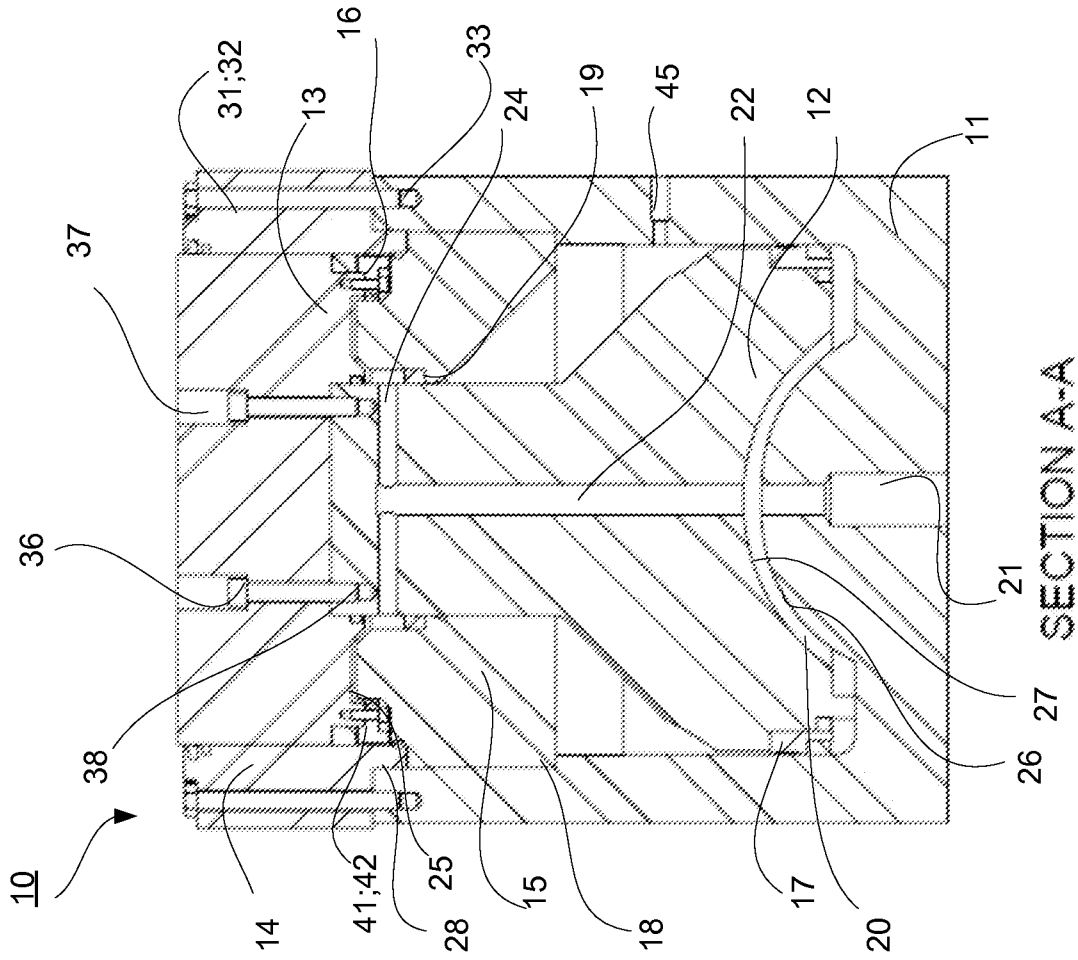

Fig. 1B

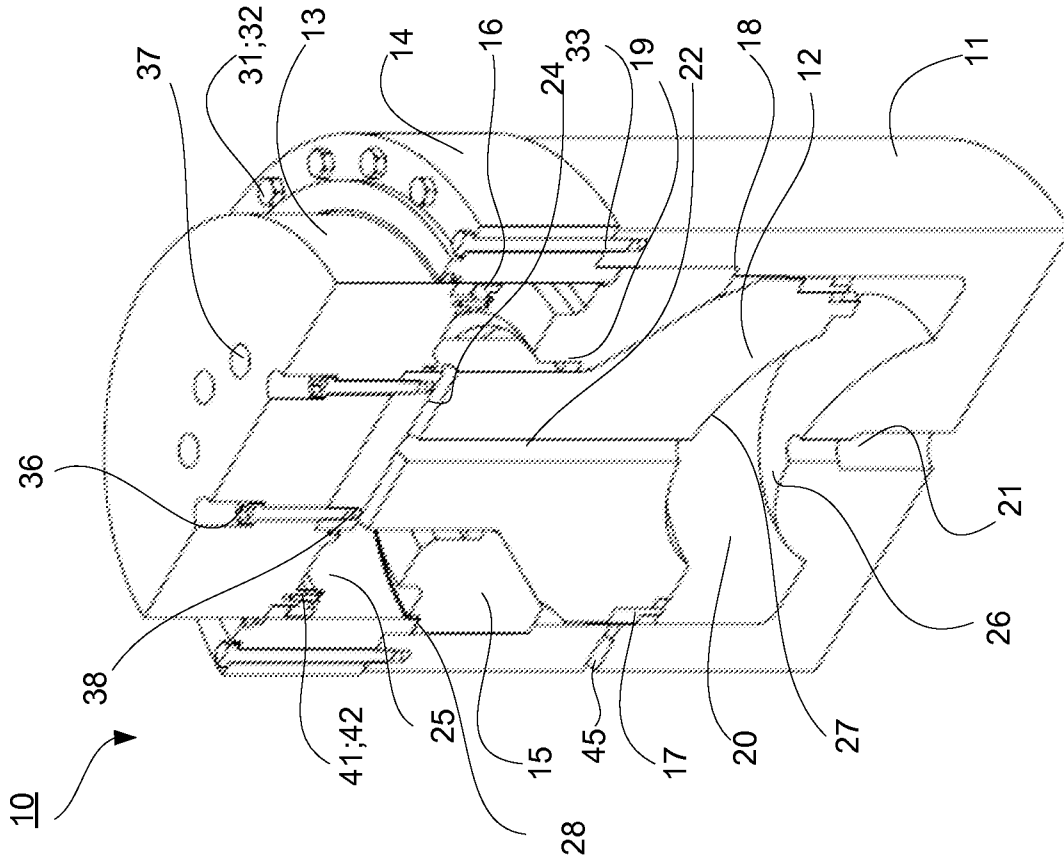

Fig. 2B

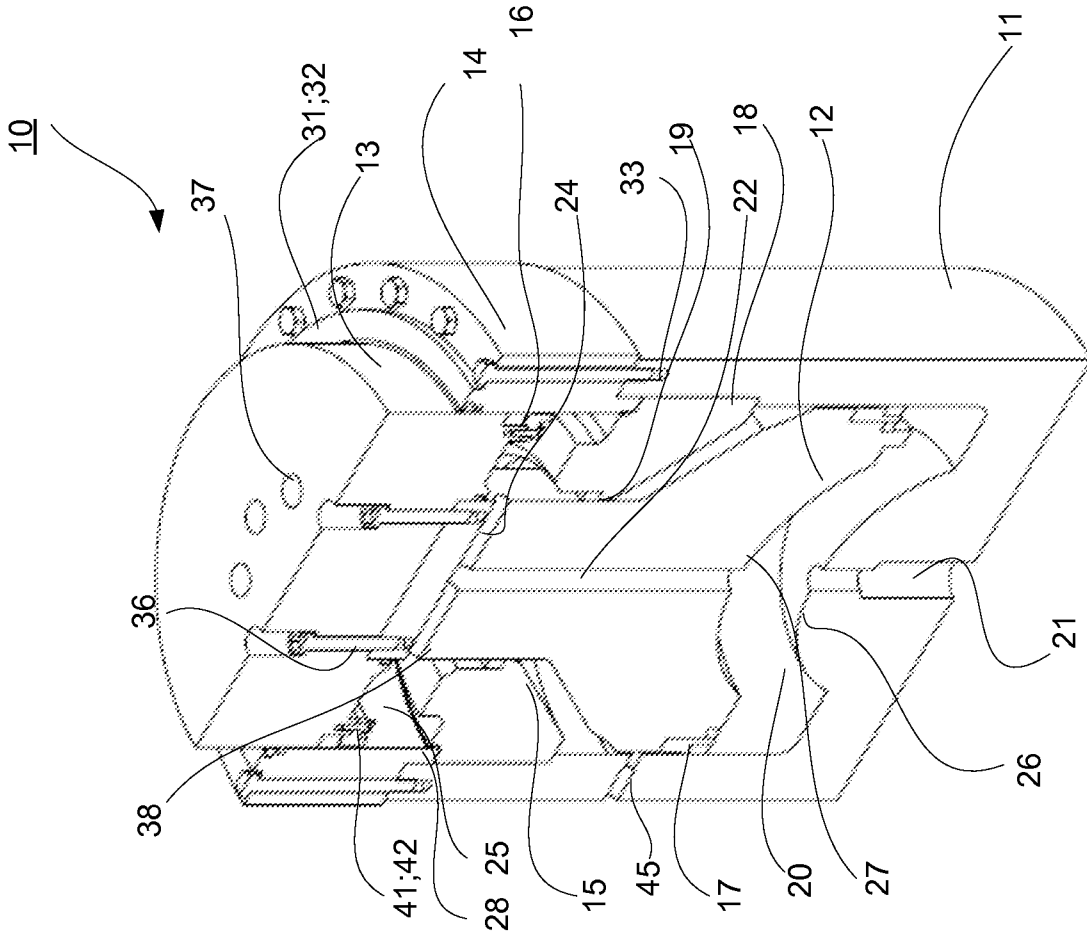

Fig. 2A

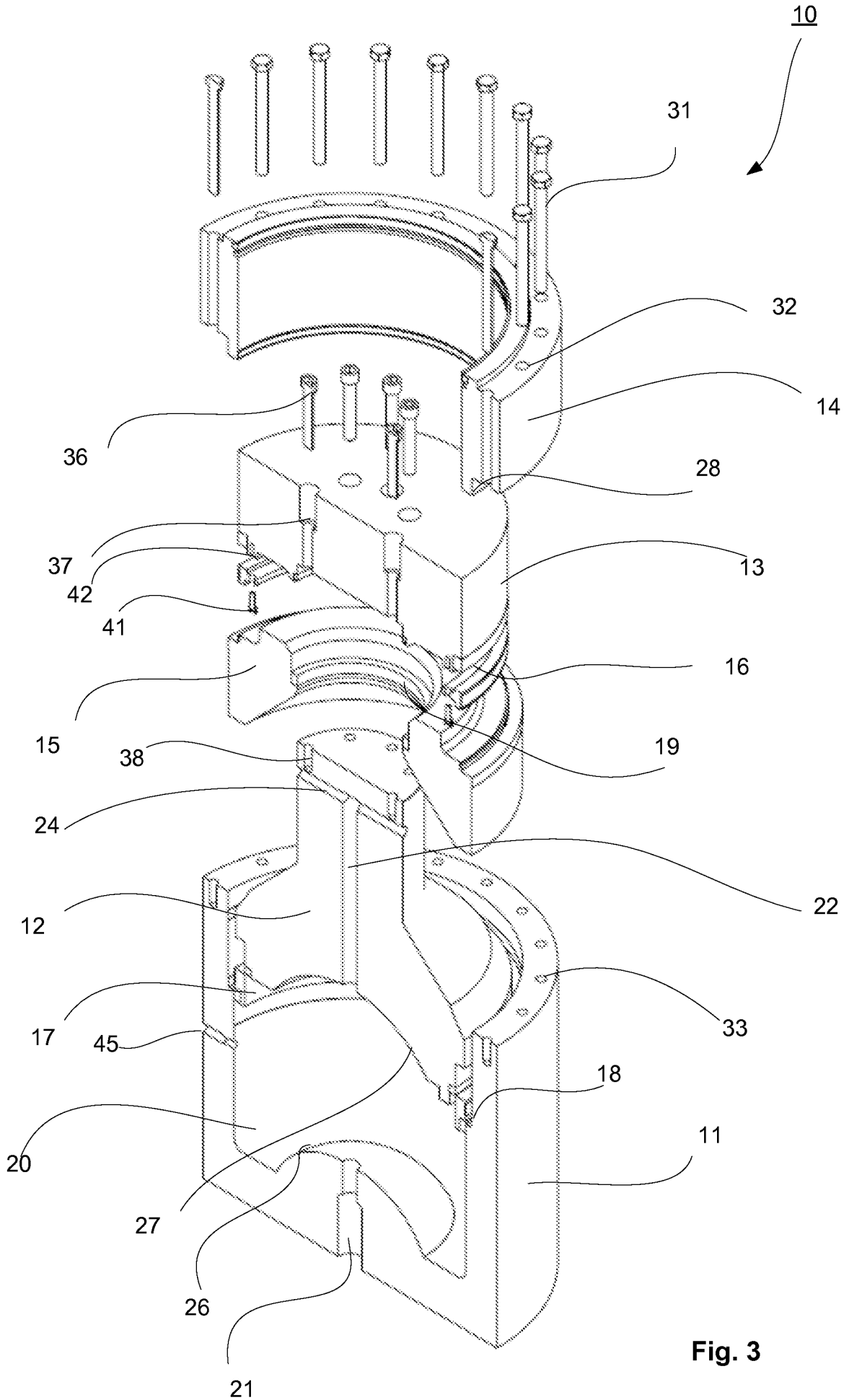

Fig. 3

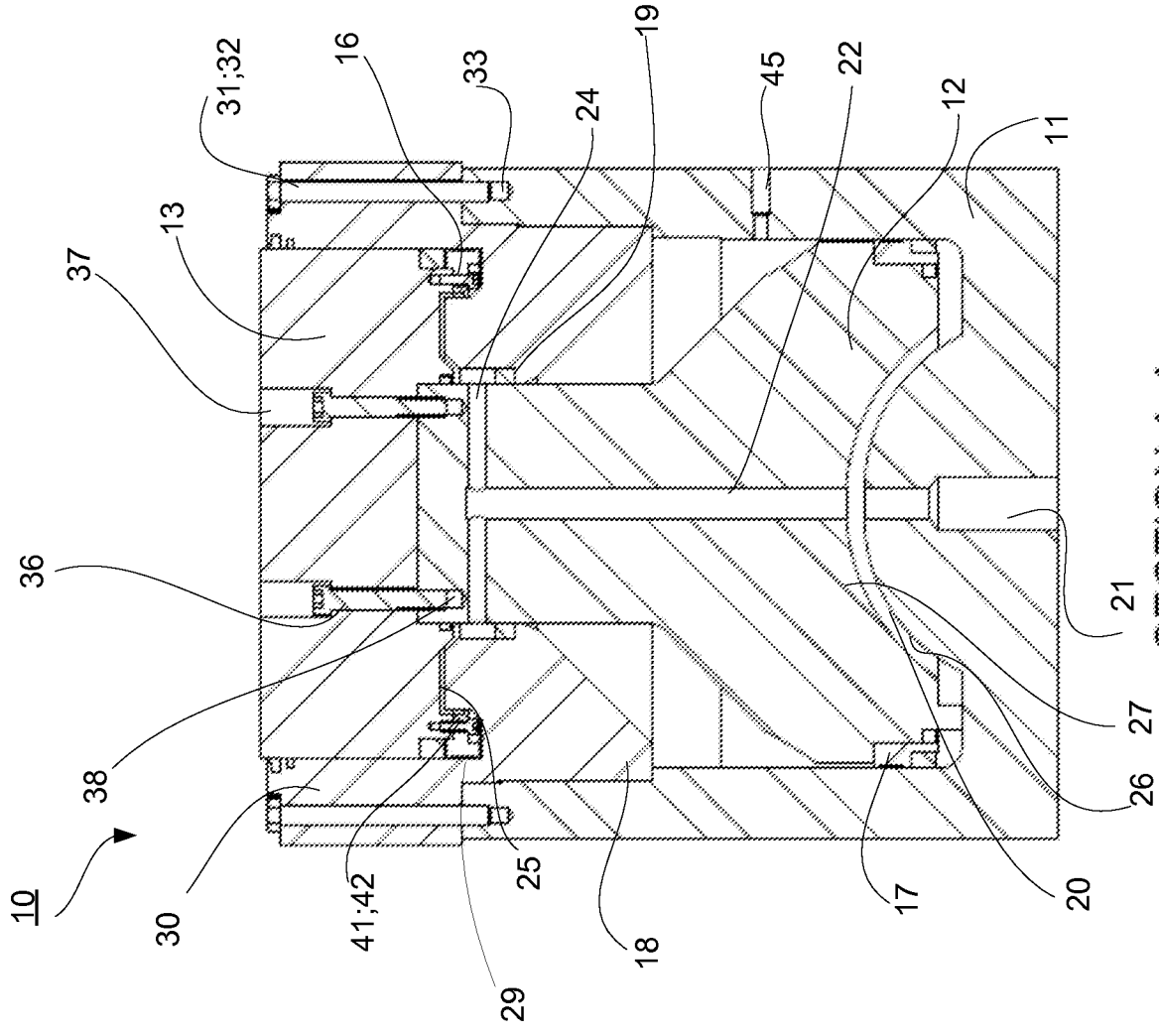

Fig. 4B

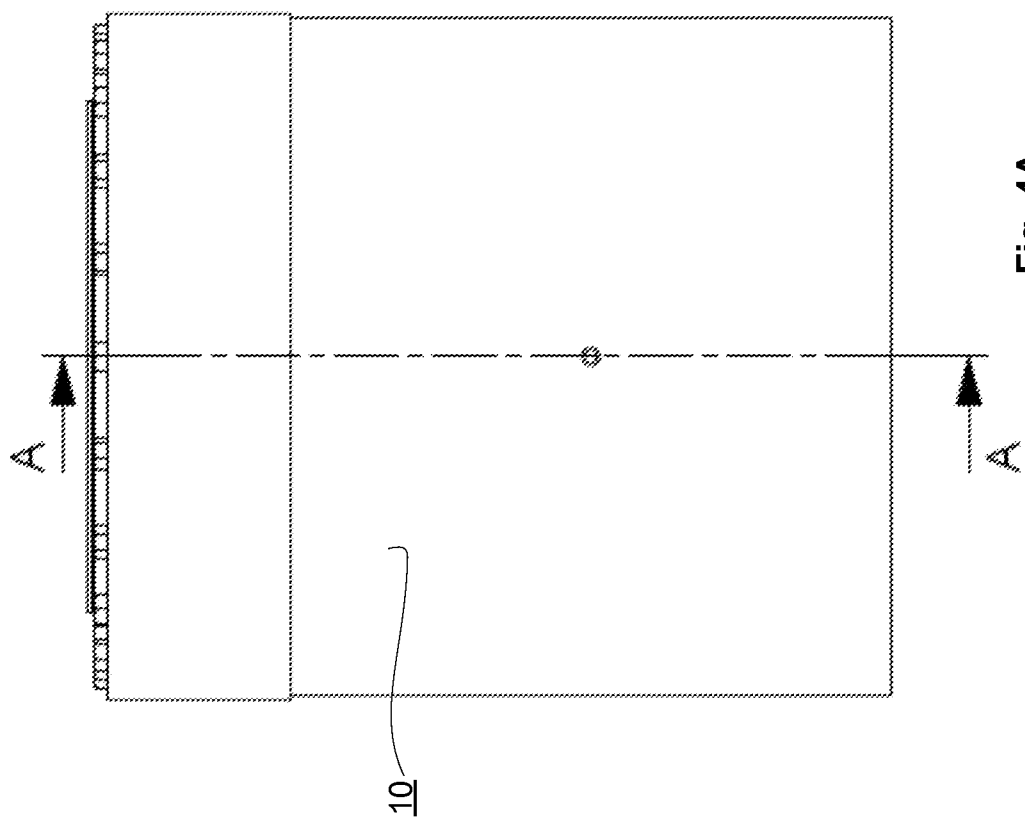

Fig. 4A

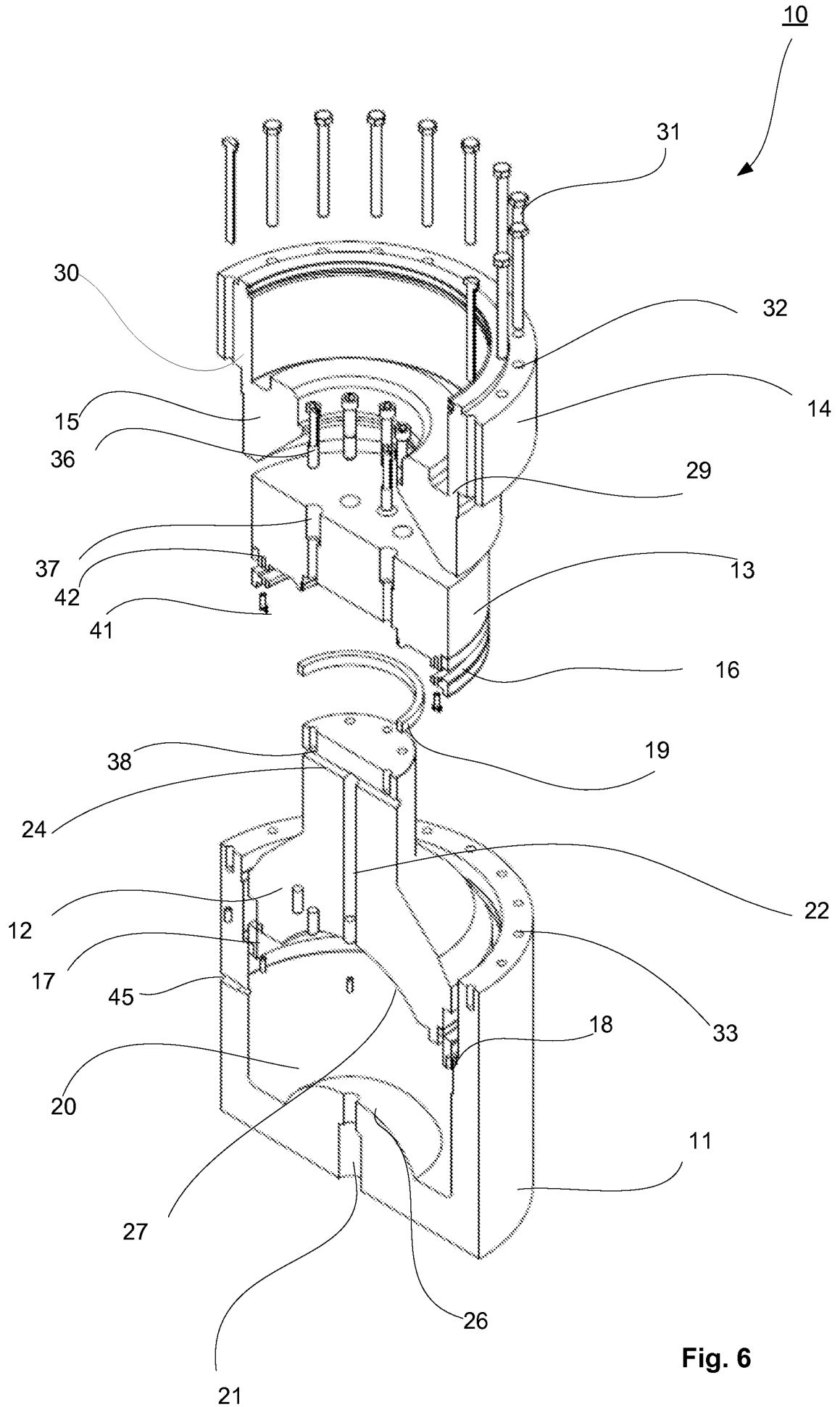

Fig. 6

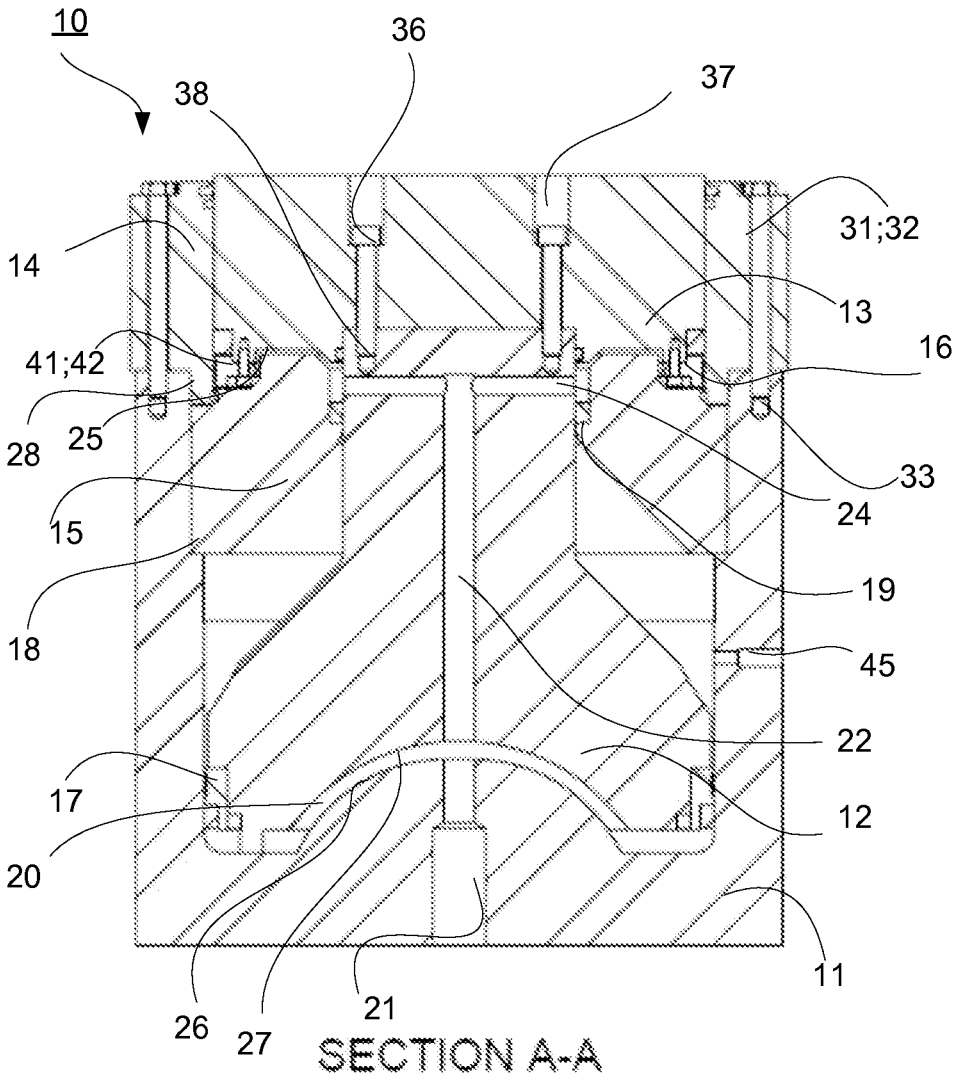

Fig. 1B