

J. M. MCGHEE.
COMBINED DESK, TABLE, AND BED.
APPLICATION FILED SEPT. 1, 1920.

1,375,524.

Patented Apr. 19, 1921.

2 SHEETS—SHEET 1.

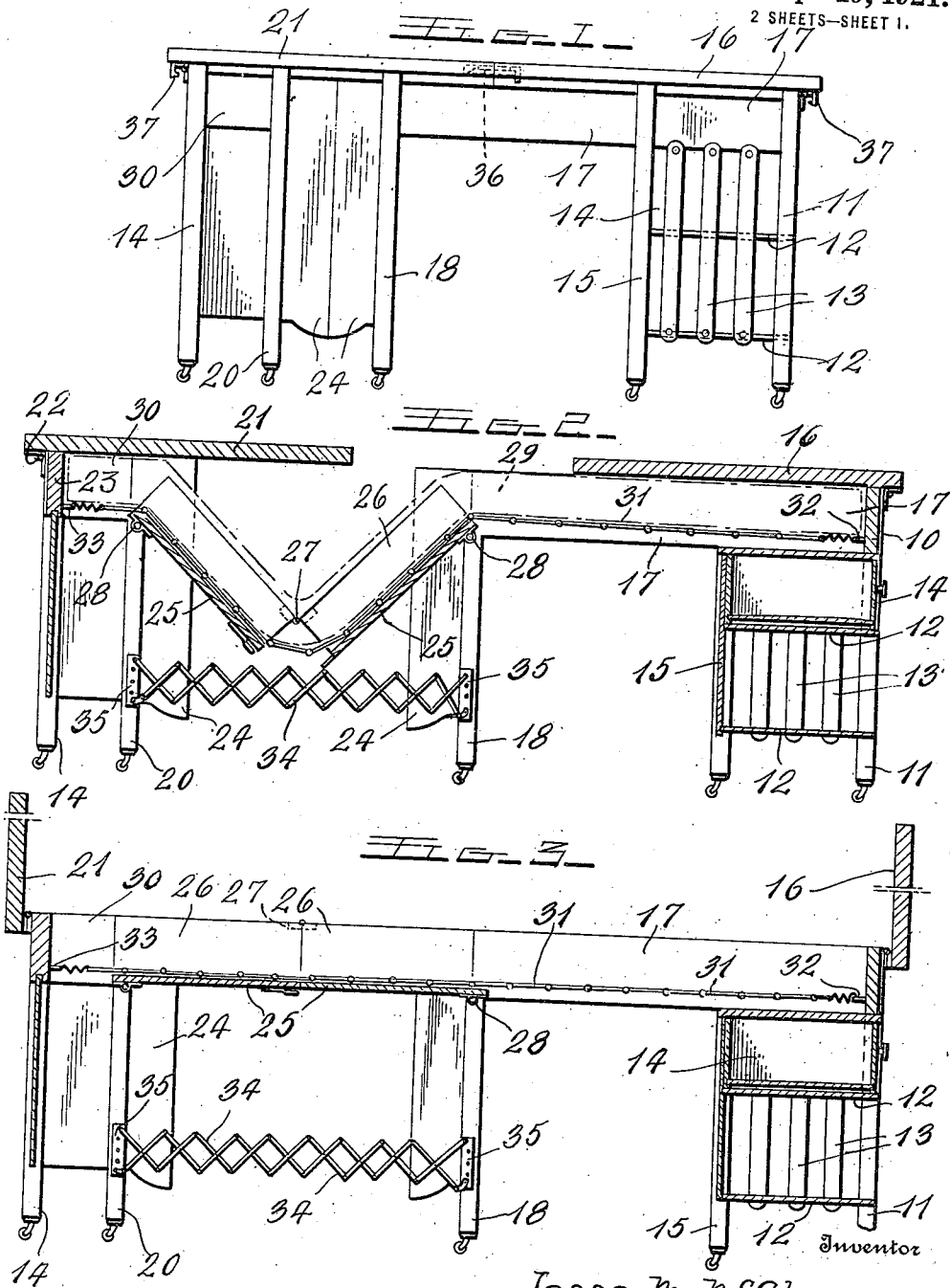

Jesse M. McGhee

Mawhinney & Mawhinney
Attorneys

J. M. McGHEE.
 COMBINED DESK, TABLE, AND BED.
 APPLICATION FILED SEPT. 1, 1920.

1,375,524.

Patented Apr. 19, 1921.

2 SHEETS—SHEET 2.

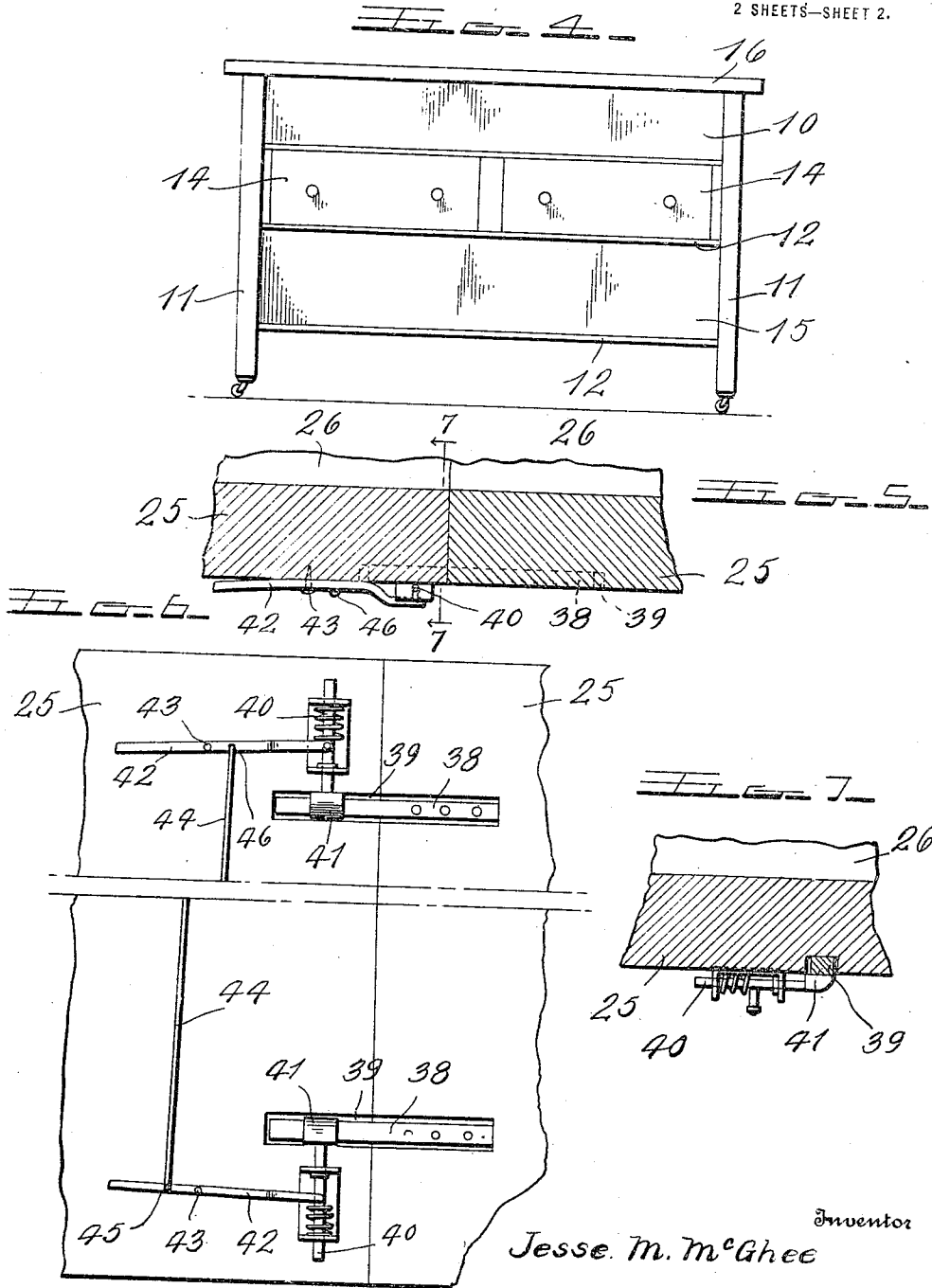

Inventor
 Jesse M. McGhee

By *Mawhinney & Mawhinney*
 Attorneys

UNITED STATES PATENT OFFICE.

JESSE M. MCGHEE, OF ESTANCIA, NEW MEXICO.

COMBINED DESK, TABLE, AND BED.

1,375,524.

Specification of Letters Patent. Patented Apr. 19, 1921.

Application filed September 1, 1920. Serial No. 407,434.

To all whom it may concern:

Be it known that I, JESSE M. MCGHEE, a citizen of the United States, residing at Estancia, in the county of Torrance and State of New Mexico, have invented new and useful Improvements in Combined Desks, Tables, and Beds, of which the following is a specification.

The present invention relates to folding beds, and more particularly to an improved construction thereof which, when folded up, may be used as a table.

An object of the present invention is to provide an improved and simplified structure of table bed which may be easily and quickly drawn out into extended position; which supports bedding and the like at all times in position for use as soon as the device is extended; which embodies features of bracing the folding or separating parts of the table; and which contemplates the provision of means for firmly holding the parts in extended position.

Another object of the present invention is to provide a table bed of such a construction that when it is folded into table form it completely houses all parts of the bed structure, bedding and the like, and may be used as a table, flat desk, or other such article, and provides ample leg room beneath the table top and various shelves, compartments and the like which are usually desirable in table structures.

Another object of the present invention is to provide a table bed structure which is such that it may be economically and easily manufactured, and which is relatively small and compact and may be easily handled, and the interlocking parts of which may be readily released from either side of the table.

The above, and various other objects and advantages of the invention will, in part be described in, and in part be understood from the following detailed description of the present preferred embodiment, the same being illustrated in the accompanying drawings, wherein—

Figure 1 is a front elevation of a table bed constructed according to the present invention and in folded position;

Fig. 2 is a longitudinal section taken therethrough in a partly extended position;

Fig. 3 is a similar view illustrating the device in an extended or set up position for use as a bed;

Fig. 4 is an end elevation of the device in folded position;

Fig. 5 is a fragmentary enlarged sectional view taken through the bottom portion of the bed section at its hinged joint and showing the automatic latch in securing position for holding the bed section in position of use;

Fig. 6 is a bottom plan view of the same; and

Fig. 7 is a transverse section thereof taken substantially in the plane indicated by the line 7—7 in Fig. 5.

In the accompanying drawings, similar parts are designated by like numerals of reference throughout the several views.

Referring to the drawings, the table bed comprises opposite end sections and a foldable bed section adapted to be collapsed or folded between the end sections when the latter are closed. One end section, which may be termed as the larger end section, comprises an end wall 10 supported upon legs 11 and which is secured to spaced apart shelves or partitions 12 closed at opposite ends by slats 13 and providing upper and lower compartments in the section, the upper compartment in the present instance having a drawer 14 therein adapted to be withdrawn through the wall or panel 10.

The shelves or partitions 12 are supported at their inner ends upon a second pair of legs 15, and the said legs 11 and 15 may be mounted on casters or the like as desired. The legs 11 and 15 terminate at their upper ends substantially in the plane of the top of the wall 10 and are adapted to support on their upper ends a leaf or top section 16 hinged to the top of the wall 10 and adapted to be swung upwardly on its hinge into vertical position to provide an end board for the bed. The elongated section is also provided with a pair of side pieces 17 which extend longitudinally at opposite sides of the section, and which are secured to the legs 11 and 15 and project inwardly beyond the same to a considerable extent and are supported at their inner ends upon a short pair of legs 18. The leaf 16 is of less length than the side pieces 17 for a purpose which will hereinafter appear.

The other end section, which may be termed the shorter section, comprises an outer pair of legs 14 and an inner pair of legs 20 supporting across their upper ends

a leaf 21 hinged at 22 to the upper end of a wall 23 closing the adjacent end of the table. The leaf 21 is adapted to be swung up into substantially vertical position to form the other end board of the bed. The leaf 21 is of greater length than the distance between the legs 19 and 20 and is adapted to overlap the upper edge portions of the pieces 17 of the long section. The two sections are adapted to be closed or moved together to bring the leaves 16 and 21 into endwise abutting relation to complete a smooth and substantially uninterrupted top for the table and to bring the inner pairs of legs 18 and 20 into closely spaced apart relation. The inner legs carry at each side of the table a pair of panel sections 24 adapted to meet at their outer edges when the table sections are closed for forming therebetween an inclosed compartment adapted to receive the bed section when folded.

The bed section comprises a pair of hingedly connected parts each of trough shape and comprising a bottom 25 of panel form having at its opposite longitudinal edges upstanding strips or boards 26 of a height corresponding substantially to that of the side pieces 17 of the long section. The two parts of the bed section are hingedly connected together at 27 by a hinge which is secured to the upper edge portions of the side pieces 26 at the adjacent or meeting corners thereof, the bed section being adapted to fold downwardly as shown in Fig. 2, as the end sections are moved together.

Each part of the bed section is pivoted at 28 to the adjacent end section, one part being hinged to the upper ends of the pair of legs 18, while the other part is hinged to the upper ends of the legs 20. The hinges 28 are so arranged that when the trough sections are swung up into extended position they form continuations of the channel defined between the side pieces 17 and are adapted to support and hold in proper position a mattress 29 and other bedding as desired.

The shorter end section is provided with side pieces 30 spaced apart in alinement with the side pieces 17 and the side pieces 17 and 30 are adapted to receive at their inner free ends the inner pivoted extremities of the upstanding strips 26 of the bed section when the latter is extended. The panels 24 are extended beyond the ends of the side pieces 17 and 30 and are of sufficient width for completely inclosing the bed section and the articles supported thereon.

A suitable spring 31 of flexible construction is secured at one end within the long section at 32 near the bottom of the channel or space and at its other end at 33 in a similar manner within the short section. The spring 31 extends throughout the sec-

tions and is adapted to lie in the troughs of the bed section and be folded downwardly therewith so that no adjustment of the spring is required in either setting up or folding the bed.

For the purpose of interbracing the end sections and relieving the pivots and hinges from undue strain incident to the opening and closing of the sections expansible and contractible braces 34 are arranged at opposite sides of the sections and between the meeting ends thereof. Each brace 34 is in the form of a lazy tongs comprising pairs of crossed and pivotally connected bars and the opposite ends of each brace 34 are suitably connected to attaching plates 35 adapted to be secured against the inner opposite ends of the body section, such as to the legs 18 and 20. The braces 34 are preferably located closely adjacent to the inner sides of the panel sections 24 and are arranged at such height that when the device is folded into table form, as shown in Fig. 1, the braces 34 are inclosed from view.

When the body sections are brought together into closed position, the leaves 16 and 21 may be interlocked by a suitable latch 36, shown in Fig. 1, for holding the sections from accidental separation. The leaves 16 and 21 may also be provided with latches 37 on their outer ends adapted for interlocking engagement with the outer end walls of the sections for holding the leaves 16 and 21 in vertical position, as shown in Fig. 3, when the device is set up as a bed.

From the above it is thought to be clear that when the table or desk, shown in Fig. 1, is to be used as a bed the latch 36 is released and the end sections of the body are drawn apart as shown in Fig. 2 for raising the bed section from folded position into the horizontal position shown in Fig. 3. As the parts of the bed section approach their horizontal extended position, the same may be locked automatically together to prevent the dropping down or folding of the bed section.

In Figs. 5, 6, and 7 a preferred type of lock or latch is shown, and wherein one section 25 carries a countersunk latch bar 38 in its lower side which projects into a recess 39 formed in the opposite bed section 25. The said opposite bed section 25 carries a spring operated latch 40 having a beveled lower edge 41 adapted to ride over the outer end of the bar 38 for retracting the latch as the bar enters the recess 39. The latch is adapted to snap beneath the bar 38 when the latter is in the recess for holding the bar therein, and thus locking the bed parts together. It is preferable to provide such a latch mechanism near each lateral edge of the bed section and to facilitate the simultaneous release of the bars 38 when it is desired to fold the bed section, the following arrangement is had.

A lever 42 is pivoted at 43 to the under side of the bed part 25 which carries the latches 40. The levers 42 are connected each at one end to the adjacent latch 40 and are
 5 free for engagement by the hand at their other ends for swinging the levers and retracting the latches. To effect the simultaneous retracting of the latches the connecting rod 44 is pivoted at a point 45 to one
 10 lever 42 at one side of its pivot 43 and the other end of the connecting rod 44 is pivoted at 46 to the other lever 42 at the other side of its pivot 43. Thus, when the free end of one lever 42 is pushed inwardly to retract
 15 the adjacent latch 40 the rod 44 is thrust transversely toward the other lever 42 and swings the attached end thereof outwardly to retract its latch 40. The levers are so connected that the connected ends thereof
 20 swing outwardly simultaneously and also swing inwardly under tension of the latch springs.

The braces 34 are so attached to the plates 35 that they are free to expand and retract so as to hold the body sections in relative position at all times and to afford a suitable interbracing and support for the sections. When the bed parts 25 are swung up into extended position the side boards or plates
 30 26 thereof abut at their outer ends against the adjacent side boards 17 and 30 and form a continuation thereof for completing the mattress supporting structure. When the leaves 16 and 21 are swung up into vertical
 35 position the entire length of the device is accessible for use as a bed. When the device is folded as shown in Fig. 1, the bed structure is entirely inclosed and the arrangement such that the bedding and articles of apparel or the like may be conveniently stored
 40 in the structure and will be entirely inclosed from view.

It will also be noted that the bed spring 31 and bedding may be maintained in proper relation with respect to the bed sections even when the device is folded so that the mere extension of the device not only positions the bed frame for use, but also raises and unfolds the bedding in its proper relation to the mattress and the spring.
 50

It is, of course, understood that various changes and modifications may be made in the details of construction and design of the above specifically described embodiment of this invention without departing from 55 the spirit thereof, such changes and modifications being restricted only by the scope of the following claims.

What is claimed is:—

1. A convertible desk-bed comprising a 60 body portion having a flat top and end pedestals with leg space beneath the top and between the pedestals, said body portion being divided vertically through one of said pedestals and at one side of said leg space, 65 and a foldable bed section housed in said body portion and adapted to fold down into said divided pedestal when the device is used as a desk.

2. In a device as specified, a pair of body 70 sections adapted to be moved toward and from each other, a pair of hingedly connected bed sections pivotally mounted between the end sections of the body portion and adapted to fold downwardly therebetween, a 75 latch bar carried upon the under side of one of said bed sections and projecting beyond the pivoted end thereof and adapted to overlap the opposite bed section when said sections are raised into extended position, and 80 a manually retractible spring pressed latch carried upon said other bed section and adapted to snap over said bar for interlocking the sections in extended position.

3. In a device as specified, a pair of body 85 sections adapted to be moved toward and from each other, a bed section foldably arranged between said body sections and having parts adapted to fold one upon the other, a latch bar carried by one part and projecting therefrom in position to overlap the other part when the bed section is extended, a latch bolt carried by said other part and adapted to snap over said bar to maintain the same against said opposite part and lock 95 the parts from folding, and manual means for releasing the latch to permit the folding of said bed parts.

JESSE M. MCGHEE.