

(19) World Intellectual Property Organization
International Bureau



(43) International Publication Date
27 December 2001 (27.12.2001)

PCT

(10) International Publication Number
WO 01/97947 A1

- (51) International Patent Classification⁷: B01D 33/03, B07B 1/46
- (21) International Application Number: PCT/GB01/02000
- (22) International Filing Date: 8 May 2001 (08.05.2001)
- (25) Filing Language: English
- (26) Publication Language: English
- (30) Priority Data: 09/596,347 17 June 2000 (17.06.2000) US
- (71) Applicants (for all designated States except US): VARCO I/P, INC. [US/US]; 2835 Holmes Road, Houston, TX 77051 (US). LUCAS, Brian, Ronald [GB/GB]; 135 Westhall Road, Warlingham, Surrey CR6 9HJ (GB).
- (72) Inventors; and
- (75) Inventors/Applicants (for US only): SCHULTE, David, Lee [US/US]; 101 Antietam Avenue, Broussard, LA 70518 (US). ADAMS, Thomas, Cole [US/US]; Route 1, Box 538, Hockley, TX 77447 (US). SEYFFERT, Kenneth, Wayne [US/US]; 1019 LaMonte Lane, Houston, TX 77018 (US). LARGENT, David, Wayne [US/US]; Route 4, Box 1017M, Cleveland, TX 77327 (US). MCCLUNG, Guy, Lamont, III [US/US]; 18007 Pleasant Wood, Spring, TX 77379 (US). WALKER, Jeffery, Earl [US/US]; 107 Valleyview, Lafayette, LA 70501 (US). MURRAY, Hector, M. [US/US]; 7027 Gentle Breeze Drive, Willis, TX 77378 (US).
- (74) Agent: LUCAS, Brian, Ronald; Lucas & Co., 135 Westhall Road, Warlingham, Surrey CR6 9HJ (GB).
- (81) Designated States (national): AE, AG, AL, AM, AT, AU, AZ, BA, BB, BG, BR, BY, BZ, CA, CH, CN, CR, CU, CZ, DE, DK, DM, DZ, EE, ES, FI, GB, GD, GE, GH, GM, HR, HU, ID, IL, IN, IS, JP, KE, KG, KP, KR, KZ, LC, LK, LR, LS, LT, LU, LV, MA, MD, MG, MK, MN, MW, MX, MZ, NO, NZ, PL, PT, RO, RU, SD, SE, SG, SI, SK, SL, TJ, TM, TR, TT, TZ, UA, UG, US, UZ, VN, YU, ZA, ZW.
- (84) Designated States (regional): ARIPO patent (GH, GM, KE, LS, MW, MZ, SD, SL, SZ, TZ, UG, ZW), Eurasian patent (AM, AZ, BY, KG, KZ, MD, RU, TJ, TM), European patent (AT, BE, CH, CY, DE, DK, ES, FI, FR, GB, GR, IE, IT, LU, MC, NL, PT, SE, TR), OAPI patent (BF, BJ, CF, CG, CI, CM, GA, GN, GW, ML, MR, NE, SN, TD, TG).

[Continued on next page]

(54) Title: A SCREEN ARRANGEMENT AND A SUPPORT STRUCTURE FOR A VIBRATORY SEPARATOR

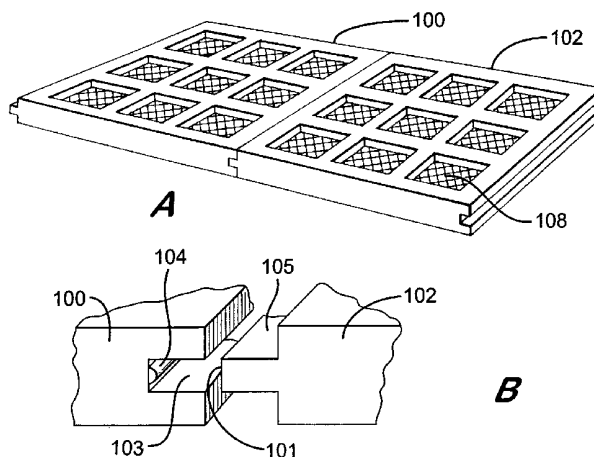

(57) Abstract: A screen arrangement for a vibratory separator, the screen arrangement comprising a first screen assembly (100) and a second screen assembly (102), the first screen assembly having a frame to which is mounted screening material, at least one seal member (104) on said frame, said at least one seal member for sealing contact against said second screen assembly. A support structure for a screen assembly for a vibratory separator, the support structure comprising a body member (70) with a portion (71) having at least one opening therethrough, and integral side portions (71a, 71b) foldable to form a pair of spaced-apart integral side members and at least one seal member (210, 212) on the integral body member for sealing contact of the unibody structure with another item. A screen arrangement for use in a vibratory separator apparatus, the screen arrangement comprising a first screen (231) with two spaced-apart first screen shoulders, a second screen with two spaced-apart second screen shoulders (236, 237), and the screens in end-to-end abutting contact with a top surface of one of the two spaced-apart second screen shoulders (246, 247) sealingly contacting a bottom surface of one of the two spaced-apart first screen shoulders.

WO 01/97947 A1



Published:

- *with international search report*
- *before the expiration of the time limit for amending the claims and to be republished in the event of receipt of amendments*

For two-letter codes and other abbreviations, refer to the "Guidance Notes on Codes and Abbreviations" appearing at the beginning of each regular issue of the PCT Gazette.

- 1 -

A SCREEN ARRANGEMENT AND A SUPPORT STRUCTURE FOR A VIBRATORY SEPARATOR

The present invention relates to a screen arrangement for a vibratory separator, a screen assembly
5 for the screen arrangement, a support structure and a vibratory separator.

Screen assemblies are generally used in shale shakers. A typical use for a shale shaker is separating
10 solids from liquids in the drilling of a wellbore for oil and gas. During drilling of a wellbore, a liquid known as mud is circulated in the well. Circulation involves introducing mud into the well and pumping the mud down a pipe such as a drill string. The mud picks up cuttings and other particles from the bottom of the wellbore and
15 are returned to the top of the well via an annulus formed by the drill pipe and the wellbore. Particle and rock laden mud exits the well and is reconditioned ready to be reused. Part of the conditioning process involves filtering the mud in a vibratory shaker, such as a shale
20 shaker. The shale shaker generally comprises a bucket, a pretensioned screen for screening the particle laden mud and a motor for vibrating the bucket and screen. A typical example of a shale shaker is disclosed in PCT Publication No. WO 96/33792, owned by the applicant for the present application. It will be appreciated that the
25 screen needs to be replaced frequently due to heavy wear. It has been found that screens can be pretensioned and mounted on a supporting structure to form a screen assembly. The screen assembly may be placed in and
30 removed from the shale shaker quickly, thereby reducing downtime of the shale shaker. Screen assemblies are arranged therein, typically placed end to end resting at their sides on a ledge welded to the bucket. Such a screen assembly is disclosed in EP-A-0 169 698. The
35 screen assemblies are generally expensive to manufacture,

- 2 -

are heavy and are prone to failure in use.

GB-A-2,206,501 discloses a frame for a filtering screen, the frame being of rectangular shape, wherein opposed ends of the frame are formed respectively with a tongue and a groove configuration, so that when in
5 abutting relationship with another frame the tongue of the next frame, forming a seal past which material to be filtered is prevented from passing.

However, it has been found that this arrangement is
10 not suitable for screen assemblies which are used in modern shale shakers. Problems with wear between adjacent screens and buffeting during the vibratory motion of the shale shaker may cause gaps to form between screens.

According to the present invention, there is
15 provided a screen arrangement for a vibratory separator, the screen arrangement comprising a first screen assembly and a second screen assembly, the first screen assembly having a frame to which is mounted screening material, at least one seal member on said frame, said at least one
20 seal member for sealing contact against said second screen assembly.

Further features of this aspect of the invention are set out in claims 2 to 15.

The present invention also provides a first and
25 second screen assembly used in the screen arrangement.

The present invention also provides a support structure for a screen assembly for a vibratory separator, the support structure comprising a body member (70) with a portion (71) having at least one opening
30 therethrough, and integral side portions (71a, 71b) foldable to form a pair of spaced-apart integral side members and at least one seal member on the integral body member for sealing contact of the unibody structure with another item.

35 Further features of this aspect of the invention are

- 3 -

set out in claims 19 to 29.

The present invention further provides a screen assembly incorporating the support structure of the invention. Other features of this aspect of the invention
5 are set out in claims 30 to 33.

The present invention also provides a screen arrangement for use in a vibratory separator apparatus, the screen arrangement comprising a first screen with two spaced-apart first screen shoulders, a second screen with
10 two spaced-apart second screen shoulders, and the screens in end-to-end abutting contact with a top surface of one of the two spaced-apart second screen shoulders sealingly contacting a bottom surface of one of the two spaced-apart first screen shoulders. Preferably, the screen
15 arrangement further comprises mating positioning apparatus on the screens for facilitating positioning of the screens with respect to each other.

The present invention also provides a vibratory separator comprising at least one support screen or
20 screen assembly or screen arrangement of the invention.

- 4 -

Figure 1A is a perspective view of two screen assemblies in accordance with the present invention, in an engaged position;

Figure 1B is an enlarged view of part of the two
5 screen assemblies of Figure 1A, in a disengaged position;

Figure 1C is a cross-section view of an end view of one of the screen assembly of Figure 1A;

Figure 2A is a perspective view of two screen
10 assemblies in accordance with the present invention, in engaged position;

Figure 2B is an enlarged view of part of the screen assemblies of Figure 2A, in a disengaged position;

Figure 3A is a perspective view of two screen
15 assemblies in accordance with the present invention, in an engaged position;

Figure 3B is an enlarged view of part of the screen assemblies of Figure 3A, in a disengaged position;

Figure 4A is a perspective view of two screen
20 assemblies in accordance with the present invention, in an engaged position;

Figure 4B is an enlarged view of part of the screen assemblies of Figure 4A, in a disengaged position;

Figure 5A to 5H are perspective views of parts of
25 screen assemblies in accordance with the present invention;

Figure 6A to 6D are perspective views of parts of screen assemblies in accordance with the present invention;

Figure 7A is a top view of a screen assembly in
30 accordance with the present invention;

Figure 7B is a cross-sectional view of an end of the screen assembly of Figure 7A;

Figure 7C is a perspective view of a frame of the screen assembly of Figure 7A;

35 Figures 8A to 8N are side cross-section views of an

- 5 -

end of a screen assembly according to the present invention;

Figure 9A is a top view of a blank used in the construction of a screen support in accordance with the present invention;

Figure 9B is a side elevation of a constructed screen support of Figure 9A;

Figure 9C is a perspective view of a partially constructed screen support of Figure 9A, with details not shown;

Figure 10A is a perspective view of a screen combination according to the present invention;

Figure 10B is an exploded view of the screen combination of Figure 10A;

Figure 10C is a bottom view of a screen for use in a screen combination as in Figure 10A;

Figure 10D is a top view of a screen for use in a screen combination as in Figure 10A;

Figure 11A is a perspective view of a screen combination according to the present invention;

Figure 11B is an exploded view of the screen combination of Figure 11A;

Figure 11C is a bottom view of a screen for use in a screen combination as in Figure 11A;

Figure 11D is a top view and Figure 11E is a bottom view of screens for use in a screen combination as in Figure 11A.

Figures 1A to 1C show two substantially identical screen assemblies in accordance with the present invention, generally identified by the reference numerals 100 and 102. Screen assembly 100 has an end with a groove 103 that extends from one side of the screen 100 to the other. A seal member 104 also extends within the groove from one side of the screen 100 to the other side.

The seal member 104 may be formed integrally of the

- 6 -

screen 100 or it maybe a separate member adhered and/or secured to the screen 100 with any suitable known adhesive, glue, and/or fastener.

5 The groove 103 is sized and configured to receive a tongue 105 of the screen assembly 102. An end surface 101 of the tongue 105 sealingly abuts the seal member 104 of the screen assembly 100.

10 The screen assemblies 100 and 102 have screening areas 108 that include screening material and are defined by cross openings in a frame.

Screens 110 and 112 as shown in Figures 2A and 2B are similar to the screen assemblies of Figure 1A; but screening material 117, 118 covers openings 117a, 118a, respectively, through the screens 110, 112, respectively.
15 Optionally, any known screen support, strips, straps, or plate may be used with the screens 110, 112 beneath the screening material.

A seal member 114 is like the seal member 104 of Figure 1B; a tongue 115 and end surface 111 are like the tongue 105 and end surface 101 of Figure 1B,
20 respectively; and a groove 113 is like the groove 103 of Figure 1B.

Figures 3A and 3B show two substantially identical screen assemblies in accordance with the present invention, generally identified by the reference numerals 25 120 and 122 which are similar to the screen assemblies of Figures 1A and 2A; but a tongue 125 of the screen assembly 122 has an end surface 121 with a groove therein that is sized, positioned, and shaped to receive therein at least a portion of a seal member 124 in a groove 123
30 of the screen assembly 120. The groove 126 extends across the tongue 125, from one side of the screen 122 to the other. Correspondingly, the seal member 124 extends across the screen assembly 120.

35 Figures 4A and 4B show two substantially identical

- 7 -

screen assemblies in accordance with the present invention, generally identified by the reference numerals 130 and 132 which are like the screens 110, 112 of Figure 2A; but the screen assembly 132 has a tongue 135 (like the tongue 115, Figure 2B) with an end surface 131 (like the end surface 11, Figure 2B) with a groove 136 that extends across the screen assembly 132 from one side to the other and sealingly receives therein at least a portion of a seal member 134 in a groove 133 (like the groove 113, Figure 2B) of the screen 130. Screening material 138 is like the screening material 118, Figure 2A, over openings, not shown, like the openings 117a, 118a of Figure 2A. The screen 130, optionally, has a seal member 139a along each of its sides 130a, 130b; and the screen 132 has a seal member 139b along each of its sides 132a, 132b. The seal members 139a, 139b may be any seal member disclosed herein adhered or secured in any manner disclosed herein. Any screen or screen assembly disclosed herein may have side seal members like the seal members 139a, 139b in addition to, or instead of, any of the end seal members disclosed herein.

Figures 5A to 5H illustrate partially various screens according to the present invention with a variety of seal members. For each of these screens, although they are shown partially, it is to be understood that they are like the complete screens or screen assemblies disclosed herein and/or referred to herein and that the structures of Figures 5A to 5H may be used for any screen or screen assembly referred to or disclosed herein.

Figure 5A shows two screen assemblies A1 with a groove A3 (like the groove 103, Figure 1B) and a seal member 140 (like the seal member 104, Figure 1B). The screen assembly A2 is like the screen assembly 102, Figures 1A, 1B. However, the seal 140 is arranged on a bottom surface of the groove A3.

- 8 -

Figure 5B shows two screen assemblies B1 with a groove B3 (like the groove 103, Figure 1B) and a seal member 141 (like the seal member 104, Figure 1B). The screen assembly B2 is like the screen assembly 102, Figures 1A, 1B. However, the seal 141 is arranged on a top surface of the groove B3.

Figure 5C shows a screen assembly C1 with a groove C3 (like the groove 103, Figure 1B) and seal members 142 and 143 (like the seal member 104, Figure 1B). The screen C2 is like the screen 102, Figures 1A, 1B. However, the seals 142 and 143 are arranged respectively on a bottom and top surface of the groove C3.

Figure 5D shows a screen D1 with a groove D3 (like the groove 103, Figure 1B) and an amount 144 of a releasably cooperating fastener material (for example hook-loop material or VELCRO - TM material). The screen D2 is like the screen 102, Figures 1A, 1B. The screen D2 has an amount 145 of a releasably cooperating fastener material (for example hook-loop material or VELCRO - TM material) on an end of a tongue D5. Additionally, seals may be provided on the top and/or bottom surfaces of the groove, as shown in Figures 5A, 5B and 5C.

Figure 5E shows a screen E1 with a groove E3 (like the groove 103, Figure 1B) and a seal member 146. The seal member 146 is held on a portion E4 of the screen E1 by a friction fit and/or by a suitable adhesive. The seal member 146 has an upper arm 147 and a lower arm 148 with a projecting rib 50 that releasably resides in a corresponding notch 149 of the portion E4. The projecting rib 50 extends along the entire length of the portion E4, but it is within the scope of this invention to use a single projecting bead or series of beads on the seal member 146 and corresponding recesses on the portion E4. The screen E2 is like the screen 102, Figures 1A, 1B.

- 9 -

Figure 5F shows a screen assembly F1 with a groove F3 (like the groove 103, Figure 1B) and a seal member 151. The seal member 151 has a portion 151a that releasably resides in a corresponding recess 152 of the screen assembly F1. Alternatively or in addition to having the seal member releasably connected to the screen assembly F3, adhesive may be used to attach the seal member 151 to the screen F3 (as may the seal member 146 be attached to the screen assembly E3, Figure 5E and any seal member in any screen disclosed herein). The screen assembly F2 is like the screen assembly 102, Figures 1A, 1B.

Figure 5G shows a screen assembly G1 with a groove G3 (like the groove 103, Figure 1B). A seal member 153 is on a tongue G4 of a screen assembly G2 (like the screen assembly 102, Figures 1A, 1B).

Figure 5H shows a screen assembly H1 with a groove H3 (like the groove 103, Figure 1B). A screen assembly H2 (like the screen 102, Figures 1A, 1B) has a tongue H4 with a seal member 155b.

Any seal member for any screen assembly disclosed herein may be connected to, attached to or formed integrally of its corresponding screen. Any seal member shown in Figures 5A to 6D is to be understood as, preferably, extending along the entire length of the side or tongue at which it is located; although shorter seal members used only on part of said sides or members are within the scope of this invention.

Figures 6A to 6D show parts of various screen assemblies. For each of these screen assemblies, although they are shown partially, it is to be understood that they are like the complete screens or screen assemblies disclosed herein and/or referred to herein and that the structures of Figures 5A - 5H may be used for any screen or screen assembly referred to or disclosed

- 10 -

herein.

As shown in Figure 6A, a screen assembly 160 has a shoulder 160a and a lower surface 161 which is sealingly abutted by an end portion 163a of a tongue 163 of a screen assembly 162 when the two screen assemblies are abutted end-to-end, for example, in a shaker basket and/or a top of the end portion 163a sealingly abuts the shoulder 160a.

Figure 6B shows screen assemblies 164 and 167 in accordance with the present invention which are similar to the screen assemblies of Figure 6A; but a shoulder 165 of the screen assembly 164 has a tapered or inclined lower surface 165a that extends across the screen assembly 164 to facilitate sealing emplacement of the screen assembly 167, for example in a shaker basket, in abutting relationship to the screen assembly 164 and/or a top surface of a tongue 166 of the screen 167 sealingly abuts the shoulder 165.

Figure 6C shows screen assemblies 168 and 171 according to the present invention. The screen assembly 168 has an end shoulder 169 with an end surface 170 and the screen assembly 171 has a ledge 172 with a ledge end surface 172a that sealingly abuts the surface 170 when the screen assemblies 168 and 171 are abutted against each other end-to-end and/or a top of the ledge 172 sealingly abuts the end shoulder 169.

Figure 6D partially shows screen assemblies 173 and 176 according to the present invention. The screen assembly 173 has a shoulder 174 and an end surface 175. The screen assembly 176 has a tongue 179 with an inclined top surface 177 extending thereacross and an inclined lower surface 178 extending thereacross. A front surface 179a of the tongue 179 is configured and positioned to sealingly contact the end surface 175 of the screen assembly 173 when the two screens abut each other end-to-

- 11 -

end and/or the surface 177 sealingly abuts the shoulder 174. Any seal member disclosed herein may be used with any screen in Figures 6A to 6D, as may be any connection material disclosed herein.

5 Figures 7A to 7C illustrate a screen assembly 180 according to the present invention, which has a perforated plate 181 having a plurality of triangular openings 181a therethrough. The openings 181a may be any suitable shape, such as square or rectangular. Optionally
10 any perforated plate disclosed herein or in a patent or application referred to herein may be used instead of the plate 181 with any pattern of openings as viewed from above (as in Figure 7A) and with any suitable glue pattern thereon. As shown in Figure 7B, screening
15 material 179 represent any screening material or combination thereof disclosed or referred to herein or in any patent or application referred to herein. The plate 181 is positioned between lips 183 of a frame 182. An end 184 has an inclined lower surface 184a that
20 facilitates emplacement of another screen assembly in end-to-end abutting relationship with the screen assembly 180. An end of such another screen assembly may sealingly abut an end surface 194 of the frame 182.

 Figures 8A to 8N illustrate various possible end
25 structures for a screen such as the screen 180 of Figure 7A. Also, such end structures may be used with any screen or screen assembly disclosed or referred to herein or in any patent or application referred to herein.

 Figure 8A shows a foam seal member 185 attached to
30 the end surface 194 of the frame 182. Figure 8B shows a seal member 186 which is urethane moulded onto the screen 180.

 Figure 8C shows a seal member 190 that releasably
35 clips onto the end 184 of the screen 180. The seal member 190 has a top part 190a, a bottom part 187, and a

- 12 -

top bead 189 that releasably is held in corresponding recess 188 of the screen frame 182. The seal member 190 may be made of any suitable material, including, but not limited to, plastic, foam, and rubber.

5 Figure 8D shows a seal member 191 which is rubber painted onto the end of the frame 182. Figure 8E shows a seal member 192, for example made of rubber, foam, or plastic, which is secured to the frame 182 with one or more screws 193 or other suitable fasteners. Any seal
10 member disclosed herein may, optionally (or in addition to adhesives or fasteners) be connected with releasable fastening material such as well-known hook-and loop fastener materials.

 Figure 8F shows a seal member 195, which is a mass
15 or bead of caulking applied on the end of the frame 182. Figure 8G illustrates a seal member 196 with a portion 198 sized and configured for receipt within a corresponding notch 197 in the frame 182. Figure 14H shows a seal member 199 which is urethane moulded onto
20 the end of the frame 182. Figure 8I shows a seal member 200 which is rubber sprayed onto the end of the frame 182.

 Figure 8J shows a seal member 201, which is urethane
molded onto the end of the frame 182. Figure 8K shows a
25 seal member 202 which is foam secured on the end of the frame 182. Figure 8L shows a seal member 203 which is rubber painted onto the end of the frame 182. Figure 8M shows a seal member 204 which is a mass or bead of caulking applied on the end of the frame 182. Figure 8N
30 shows a seal member 209 which is a rubber coating applied by dipping the end 182 into a liquid mass of rubber. The seal member 209 has a top portion 206, a mid portion 207 and a bottom portion 205.

 Figures 9A, 9B and 9C show a UNIBODY structure
35 (as described in co-pending PCT Application No.

- 13 -

PCT/GB01/01610, which is owned by the applicants for the present case and which is incorporated herein for all purposes). The support structure 70 is made from a single sheet of metal in a one piece structure. The support structure 70 comprises a body member with a portion 71 having at least one opening therethrough, and preferably a plurality of openings 76 (similar to that shown in Figure 7A). The portion 71 has integral side portions 71a, 71b foldable to form a pair of spaced-apart integral side members. The support structure is provided with integral end portions 73a, 75a folded to form a pair of spaced-apart integral end members 73, 75 configured with a ledge portion and a shoulder support portion respectively. The end members 73, 75 are provided with a seal member 210 and a seal member 212 for sealing contact of the unibody support structure with another item. Either one of the seal members may be deleted. The seal members 210, 212 may be applied to the unibody support structure at any time in the process of making a screen assembly with the unibody structure. Any seal member disclosed herein may be used as the seal member 210 or the seal member 212. Alternatively, a portion of the unibody structure itself may be bent or formed to form the seal members.

The side portions 71a, 71b of the body member 71 may be provided with sub-portions foldable to form a hook strip (not shown) on each of two opposed sides of the support structure.

The support structure 70 has a further portion 72 having a plurality of spaced-apart openings, slots or cuts 72a. The openings, slots or cuts 72a define a plurality of tongue portions 72b foldable along lines 72c from the further portion 72 to form a plurality of spaced-apart support strips or ribs 78. Preferably, the tongue portions 72b are folded out of the page, as shown

- 14 -

in Figure 9A. The tongue portions 72b preferably have ends which are folded into a flat top or C-shape, as shown in Figure 9C. The plurality of spaced-apart support strips or ribs 78 connected to and beneath the portion 71 of the integral body member with the plurality of spaced-apart screening openings. The plurality of spaced-apart support strips or ribs 78 are substantially parallel to each other.

The further portion 72 is foldable over at least a part of the portion 71. The support structure 70 may be integral with a filtering means. At least one sheet of screening material may be arranged on the portion 71 over the openings 76.

Figures 10A and 10B illustrate a screen combination according to the present invention which includes a first screen 231 and a second screen 232 according to the present invention. The screens 231, 232 each have substantially identical frames 233, 234 which. The frame 233 has a top 235 and shoulders 236, 237 that project from a base 238. Screening material 239 (any disclosed herein) is over an opening 240 through the frame 233. Alternatively the frame itself may have a pattern or series of openings therethrough (any desired or referred to herein) over which screening material is placed. Any two similar screens according to the present invention may be used instead of the screens 231, 232.

As shown in Figure 10A a shoulder 246 of the screen 232 (like the shoulder 236) is positioned beneath the shoulder 237 of the screen 231. The screen 232 has screening material 259 thereon. Preferably the shoulder 246 sealingly contacts the shoulder 237 along its length. The screen 232 also has a shoulder 247 and a base 248. The positioning illustrated in Figure 10A is the positioning the screens have in the basket of certain vibratory separators. Any shape disclosed herein may be

- 15 -

used for the shoulders and any seal or seal member or members disclosed herein may be used thereon.

Figures 10C and 10D illustrate optional embodiments for the screens 231, 232. As shown in Figure 10C the shoulder 237 of the screen 231 has a recess 251 formed in the shoulder. A positioning member 252 projects upwardly from the top of the shoulder 246 of the screen 232. The positioning member 252 is sized, shaped, positioned and configured for receipt within the recess 251 to facilitate correcting positioning of the screen 232 with respect to the screen 231. A screen according to the present invention may have both a recess as the recess 251 and a positioning member as the member 252.

Figures 11A and 11B illustrate a screen combination 260 according to the present invention which includes a first screen 261 and a second screen 262 according to the present invention. The screens 261, 262 each have, respectively, a frame 263, 264 which are substantially identical. The frame 263 has a top 265 and shoulders 266, 267 that project from a base 268. Screening material 269 (any disclosed herein) is over an opening 270 through the frame 263. Alternatively the frame itself may have a pattern or series of openings therethrough (any desired or referred to herein) over which screening material is placed. Any two similar screens according to the present invention may be used instead of the screens 231, 232.

As shown in Figure 11A a shoulder 276 of the screen 262 (like the shoulder 266) is positioned beneath the shoulder 267 of the screen 261. The screen 262 has screening material 289 thereon. Preferably the shoulder 276 sealingly contacts the shoulder 267 along its length. The screen 262 also has a shoulder 277 and a base 278. The positioning illustrated in Figure 11A is the positioning the screens have in the basket of certain

- 16 -

vibratory separators. Any shape disclosed herein may be used for the shoulders and any seal or seal member or members disclosed herein may be used thereon.

5 Figure 11C shows the screen 262 being placed into position with respect to the screen 261.

10 Figures 11D and 11E illustrate optional embodiments for the screens 261, 262. As shown in Figure 11D the shoulder 267 of the screen 261 has recesses 281 formed in the shoulder. Positioning members 282 project upwardly from the top of the shoulder 276 of the screen 262. The positioning members 282 are sized, shaped, positioned and configured for receipt within the recesses 281 to facilitate correcting positioning of the screen 262 with respect to the screen 261. A screen according to the present invention may have both recesses as the recesses 15 281 and positioning members as the members 282.

- 17 -

CLAIMS:

1. A screen arrangement for a vibratory separator, the screen arrangement comprising a first screen assembly and a second screen assembly, the first screen assembly
5 having a frame to which is mounted screening material, at least one seal member on said frame, said at least one seal member for sealing contact against said second screen assembly.
2. A screen assembly as claimed in Claim 1, wherein
10 said second screen assembly has a frame, screening material mounted therein.
3. A screen assembly as claimed in Claim 2, wherein said frame of said first screen assembly has a groove and said frame of said second screen assembly has a tongue,
15 in use, said groove in said first screen receives said tongue in said frame of said second screen assembly.
4. A screen assembly as claimed in Claim 3, wherein the at least one seal member is within said groove of said first screen assembly and the tongue of said second
20 screen assembly is positionable with a part thereof in sealing contact with said at least one seal member.
5. A screen assembly as claimed in Claim 3 or 4, wherein said tongue (125; 135; H4) has a recess (126; 136; 154) therein for receiving a portion of said at
25 least one seal member (124; 134; 155a).
6. A screen assembly as claimed in Claim 3, 4 or 5, wherein said at least one seal member comprises two spaced-apart seal members (142, 143; 144, 145; 155a, 155b); .
- 30 7. A screen assembly as claimed in Claim 6, wherein each of said two spaced-apart seal members (142; 143) are located in said groove (C3), preferably located on opposing faces of said groove (Fig. 5C).
8. A screen assembly as claimed in any preceding claim,
35 wherein said frame of said first screen assembly has an

- 18 -

end portion (147) and wherein said at least one seal member further comprises a channel-shaped member (146) partially encompassing part of the end portion of said first screen assembly.

5 9. A screen assembly as claimed in Claim 8, wherein said channel-shaped member (146) has a bead (150) projecting therefrom and the end portion (E4) of the first screen assembly has a correspondingly-shaped recess (149) for receiving said bead (146) for facilitating
10 emplacement of the at least one seal member on the end portion (E4) of the first screen assembly.

10. A screen assembly as claimed in any preceding claim, wherein said first screen assembly has an end portion (F3) with a notch (152) therein and said at least one
15 seal member (151) has a correspondingly-shaped portion for receipt within said notch (152) to hold said at least one seal member (151) to the first screen assembly.

11. A screen assembly as claimed in any preceding claim, wherein said at least one seal member is secured to said
20 first screen assembly with at least one fastener.

12. A screen assembly as claimed in any preceding claim, further comprising a perforated plate (181) secured to or integral with said frame, and preferably, at least one layer of screening material on said perforated plate
25 (181).

13. A screen assembly as claimed in any preceding claim, wherein the at least one seal member is attached to the frame.

14. A screen assembly as claimed in any preceding claim, wherein the at least one seal member is formed of the
30 frame.

15. A screen assembly as claimed in any preceding claim, wherein the frame is comprised of interconnected sides and the at least one seal member extends along
35 substantially an entire length of one of the sides.

- 19 -

16. A first screen assembly of the screen arrangement as claimed in any preceding claim.
17. A second screen assembly of the screen arrangement as claimed in any preceding claim.
- 5 18. A support structure for a screen assembly for a vibratory separator, the support structure comprising a body member (70) with a portion (71) having at least one opening therethrough, and integral side portions (71a, 71b) foldable to form a pair of spaced-apart integral
- 10 side members and at least one seal member on the integral body member for sealing contact of the unibody structure with another item.
19. A support structure as claimed in Claim 18, wherein the another item is a second screen assembly.
- 15 20. A support structure as claimed in claim 18 or 19, wherein said portion has a plurality of openings (76) therethrough defining a pattern.
21. A support structure as claimed in claim 18, 19 or 20, wherein the body member (70) also has integral end
- 20 portions folded to form a pair of spaced-apart integral end members (73, 75).
22. A support structure as claimed in Claim 21, wherein one of the pair of spaced-apart end portions (73, 75) is configured with a shoulder support portion (75) for
- 25 sealingly abutting a screen ledge end of an adjacent screen.
23. A support structure as claimed in Claim 22, wherein one of the pair of spaced-apart end portions (73, 75) is configured with a ledge portion (73) for sealingly
- 30 abutting a shoulder portion of an end of an adjacent screen.
24. A support structure as claimed in any of claims 18 to 23, wherein the side portions (71a, 71b) include sub-portions foldable to form a hook strip on each of two
- 35 opposed sides of the support structure.

- 20 -

25. A support structure as claimed in any of claims 18 to 23, wherein the body member (70) has a further portion (72) having a plurality of spaced-apart openings, slots or cuts (72a).
- 5 26. A support structure as claimed in Claim 25, wherein said openings, slots or cuts define a plurality of tongue portions (72b) foldable from said further portion (72) to form a plurality of spaced-apart supports (78).
27. A support structure as claimed in Claim 26, wherein
10 said further portion (72) is foldable over at least a part of said portion (71).
28. A support structure as claimed in Claim 26 or 27, wherein said tongue portions (72b) have ends which are folded into a flat top or C-shape.
- 15 29. A support structure as claimed in any of claims 18 to 27, wherein said support structure is integral with a filtering means.
30. A screen assembly comprising a support structure as claimed in any of claims 18 to 29, further comprising at
20 least one sheet of screening material over said at least one opening.
31. A screen assembly as claimed in claim 30, wherein said screening material is an undulating screen.
32. A screen assembly as claimed in Claim 30 or 31,
25 further comprising at least another layer of screening material overlaying said at least one sheet of screening material.
33. A screen assembly as claimed in Claim 30, 31 or 32, wherein said at least one sheet of screening material is
30 bonded to the support structure, preferably with a hot melt glue.
34. A screen arrangement for use in a vibratory separator apparatus, the screen arrangement comprising a first screen with two spaced-apart first screen
35 shoulders, a second screen with two spaced-apart second

- 21 -

screen shoulders, and the screens in end-to-end abutting contact with a top surface of one of the two spaced-apart second screen shoulders sealingly contacting a bottom surface of one of the two spaced-apart first screen
5 shoulders.

35. A screen arrangement as claimed in Claim 34 further comprising mating positioning apparatus on the screens for facilitating positioning of the screens with respect to each other.

10 36. A vibratory separator comprising at least one support screen or screen assembly or frame combinations as claimed in any preceding claim.

1/12

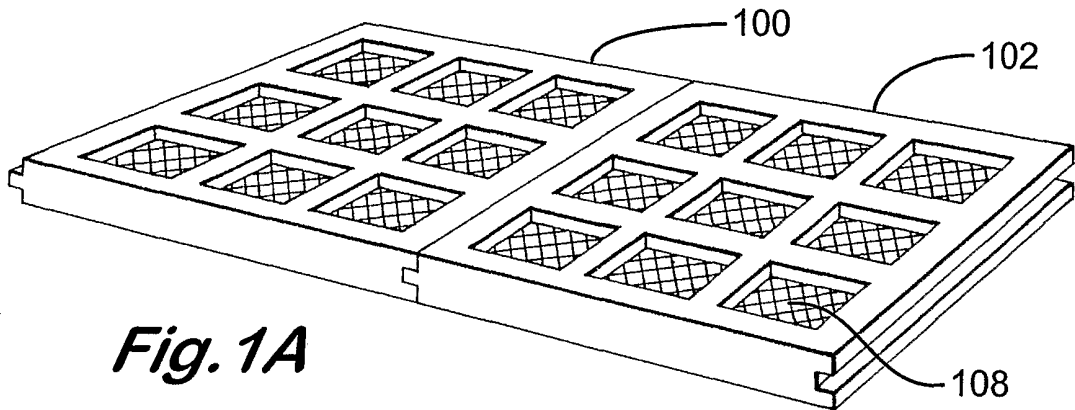

Fig. 1A

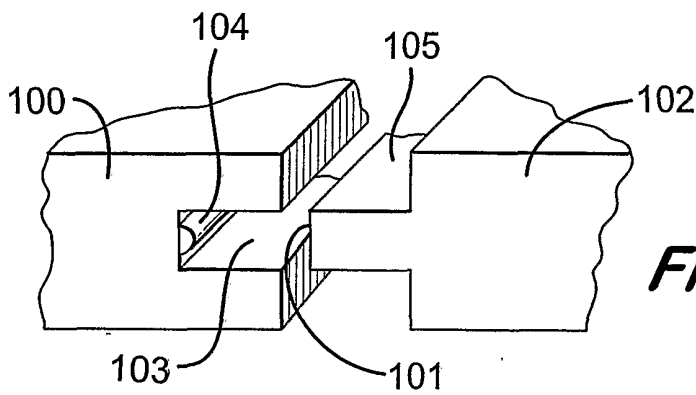

Fig. 1B

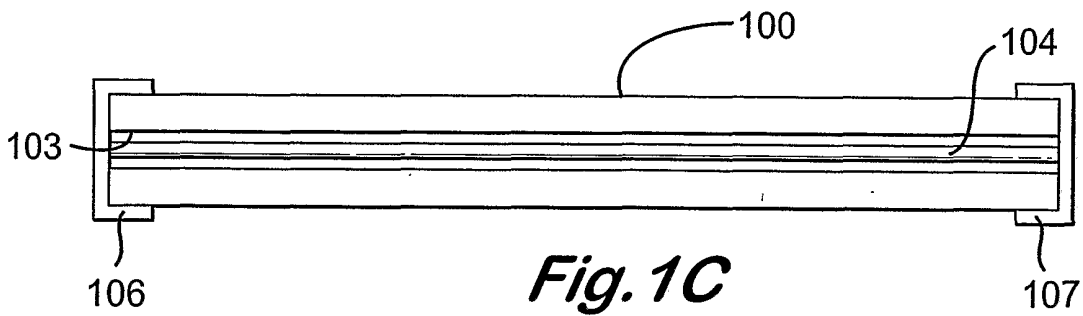

Fig. 1C

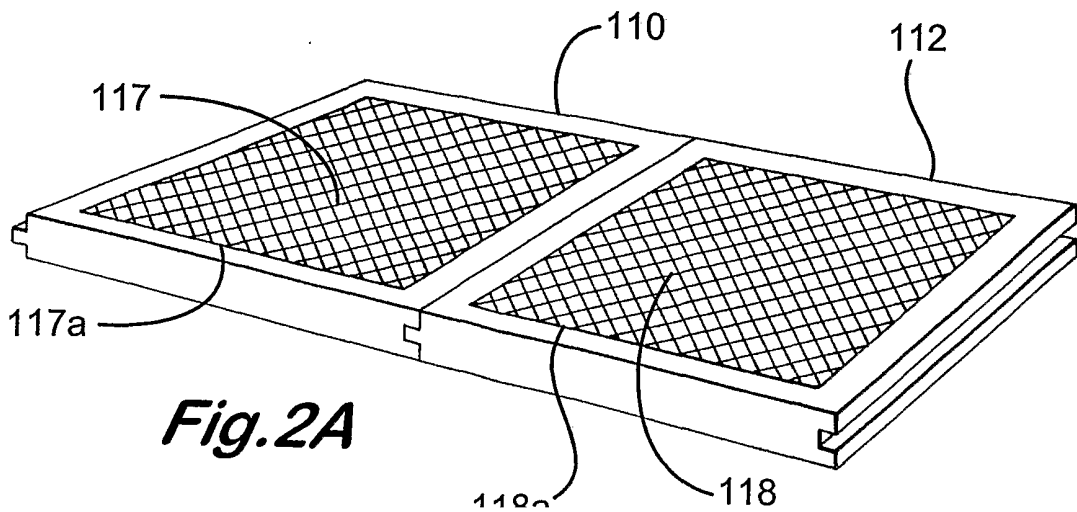

Fig. 2A

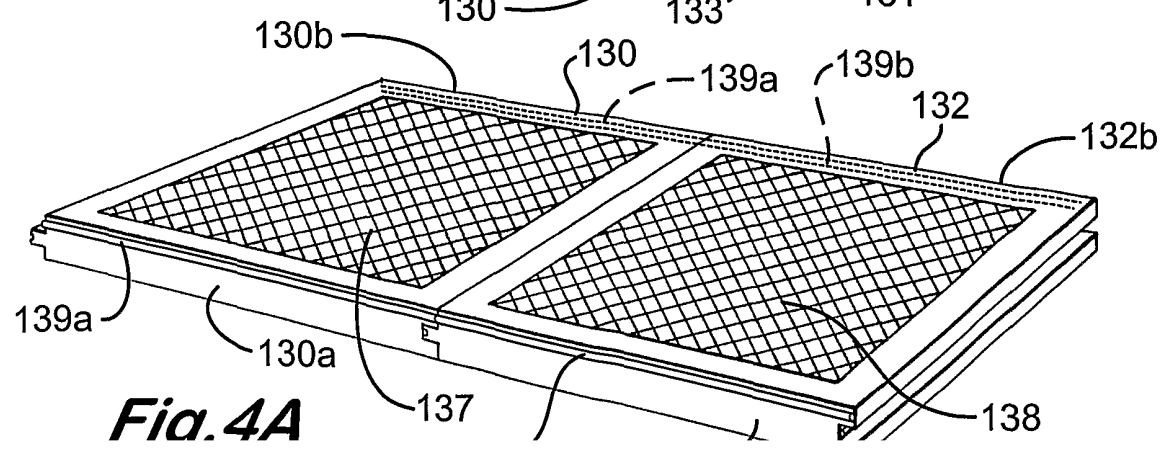
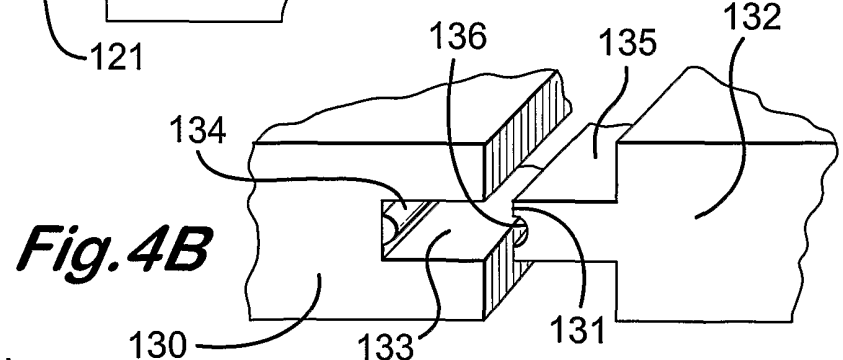
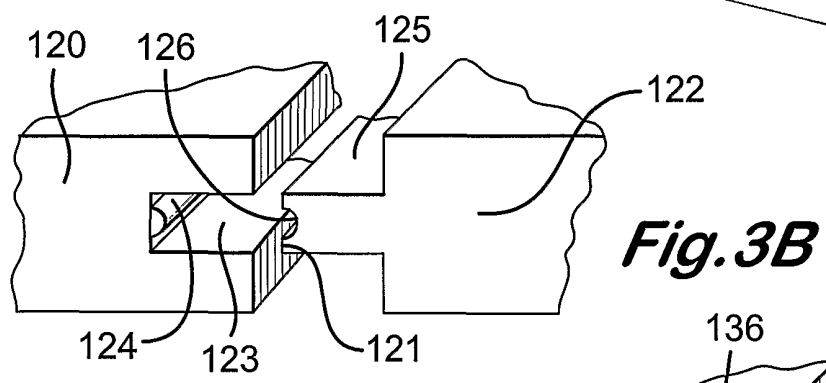
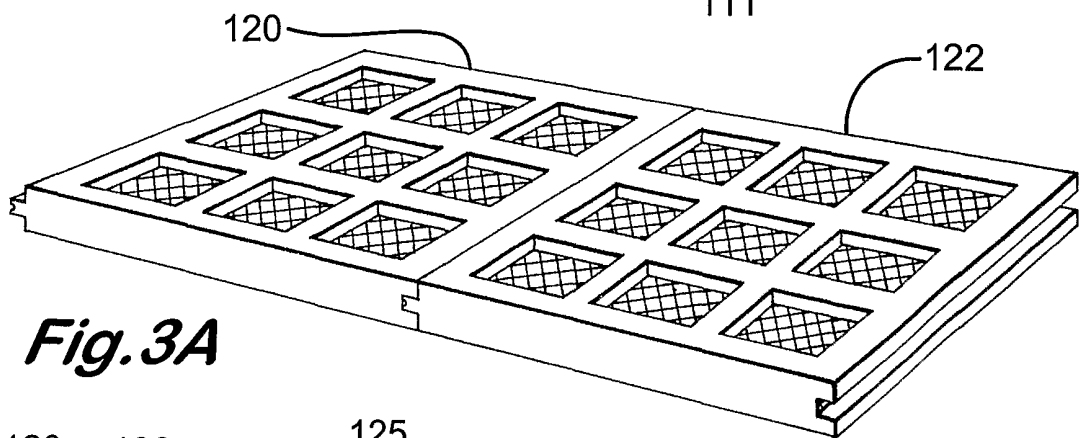
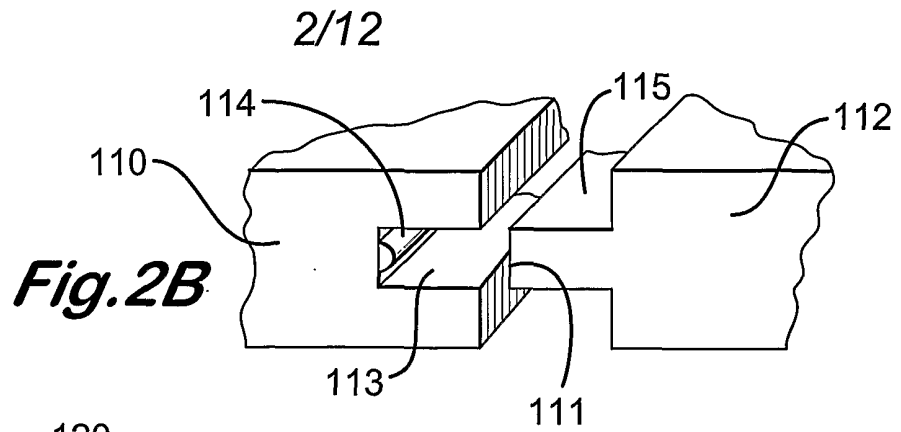

Fig. 5A

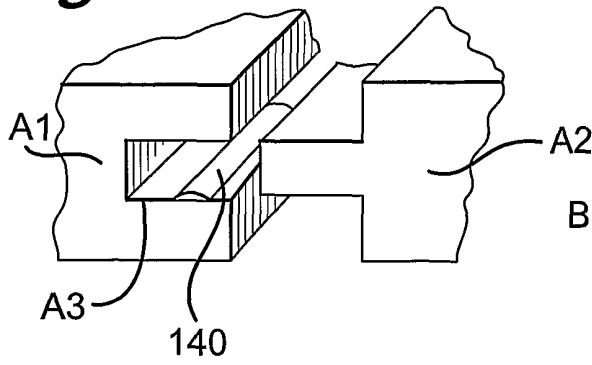

Fig. 5B

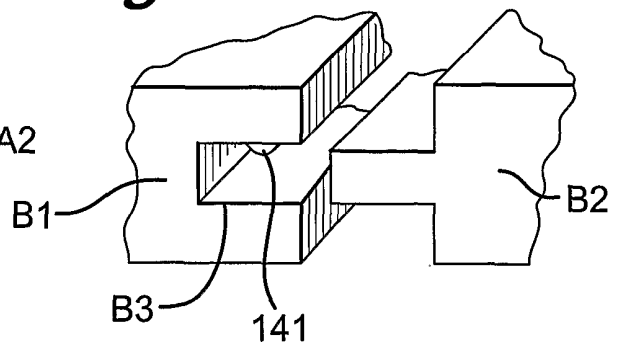

Fig. 5C

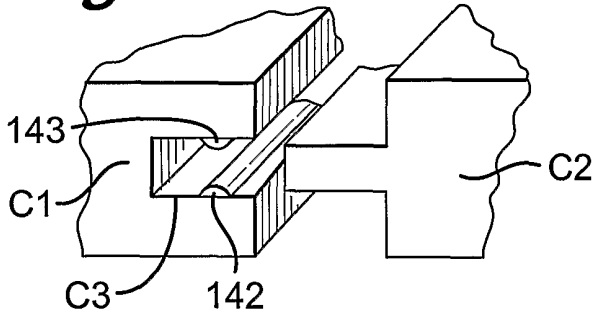

Fig. 5D

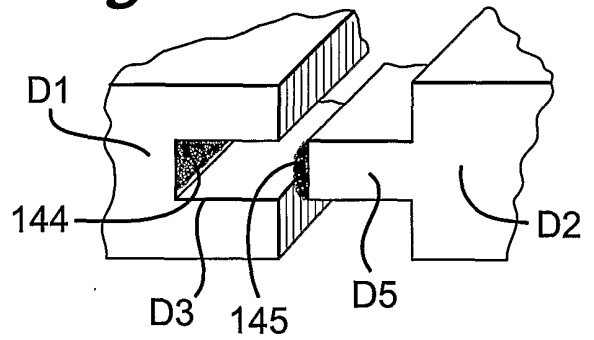

Fig. 5E

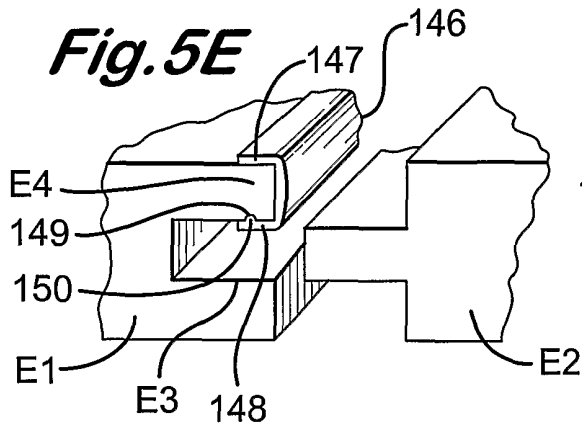

Fig. 5F

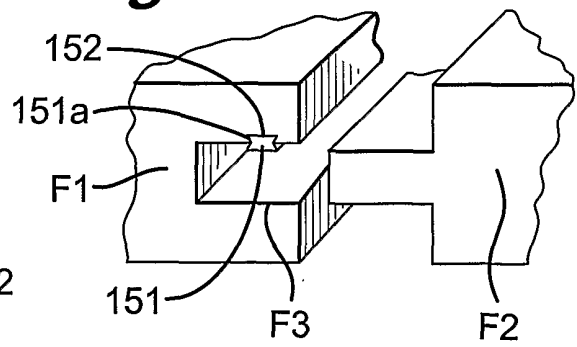

Fig. 5G

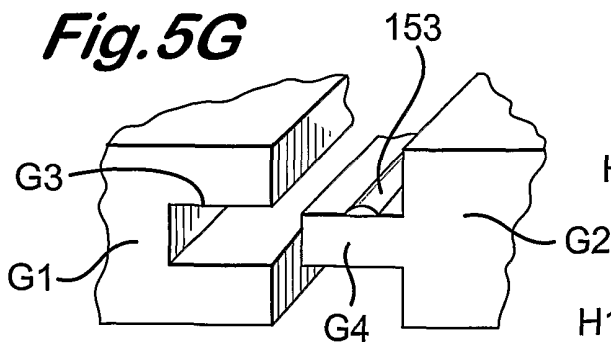
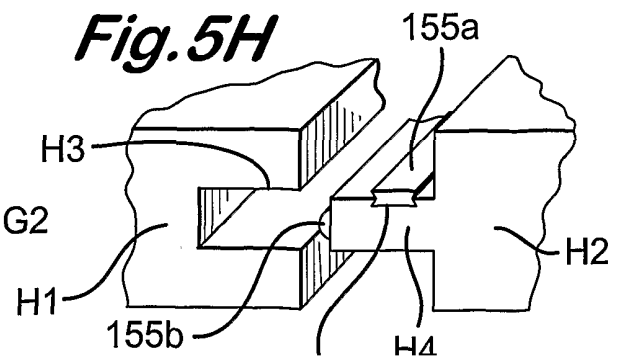
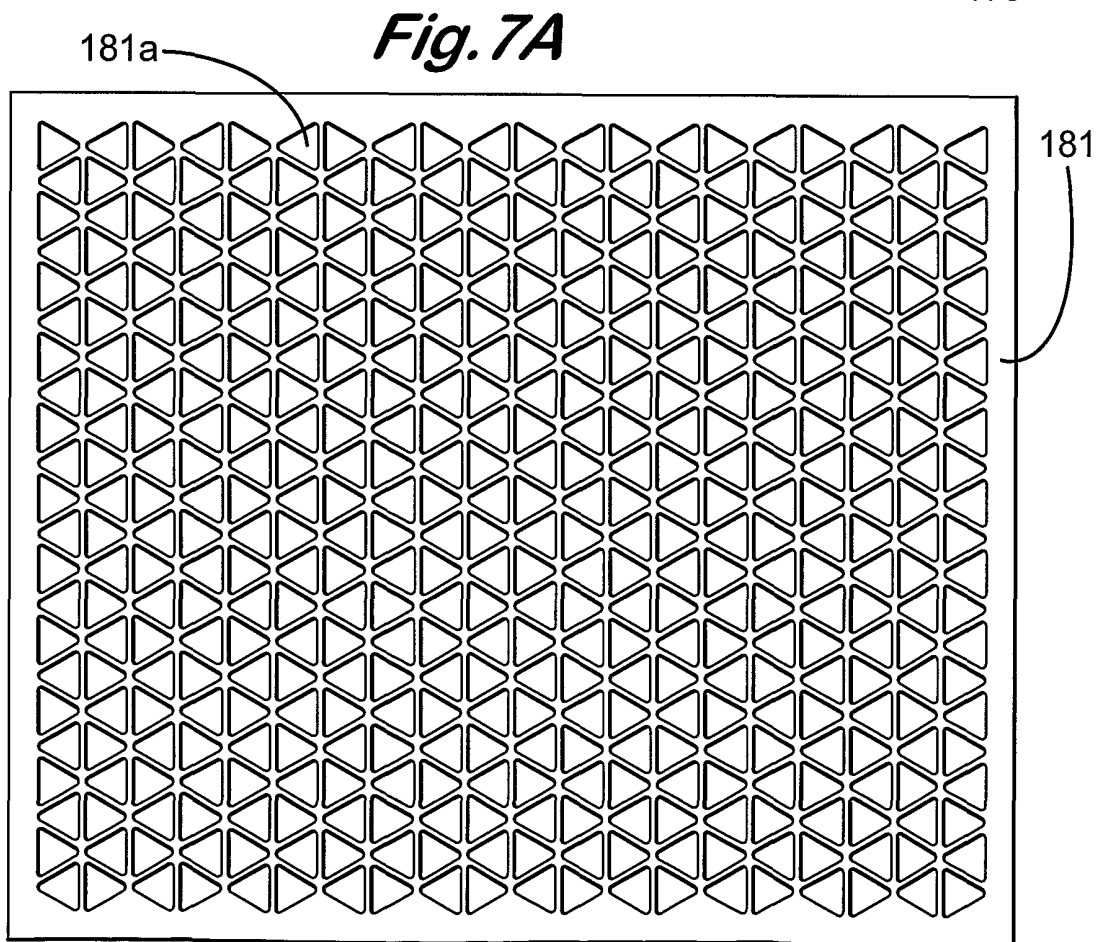
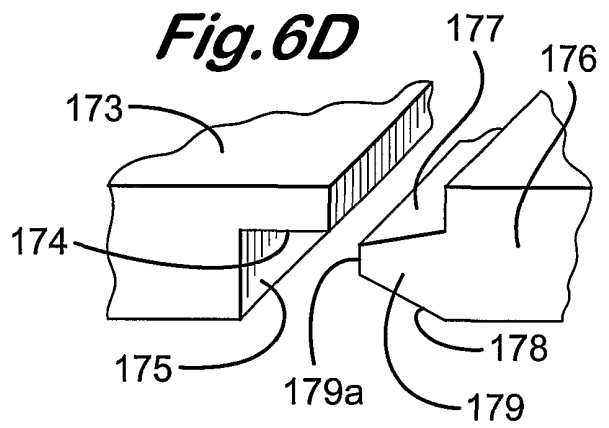
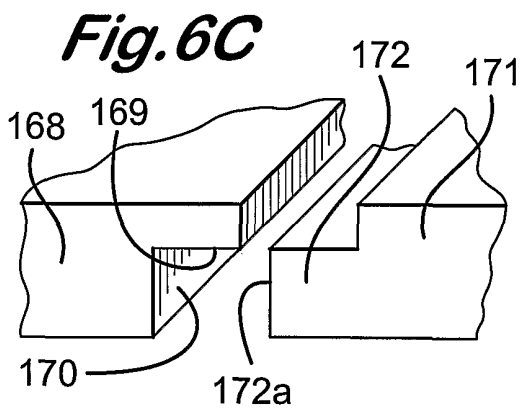
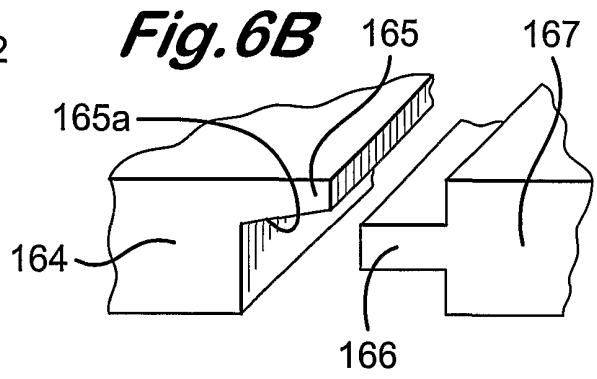
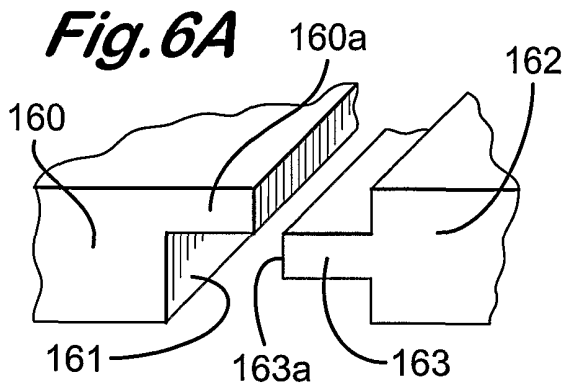

Fig. 5H





5/12

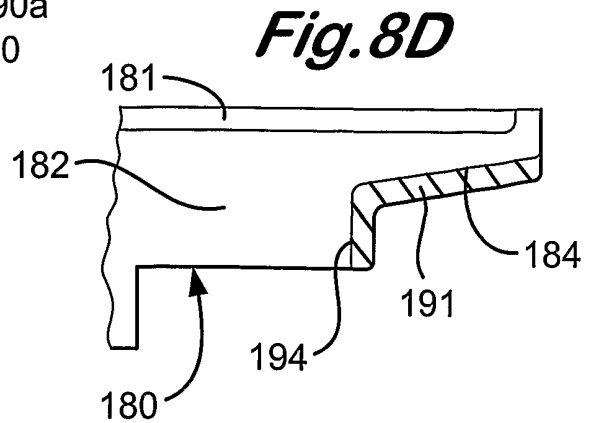
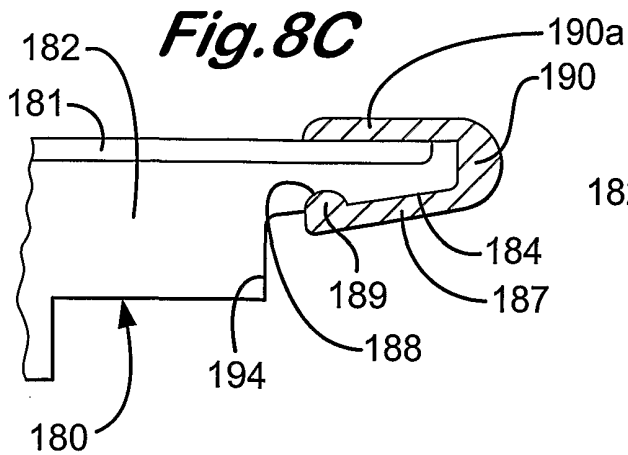
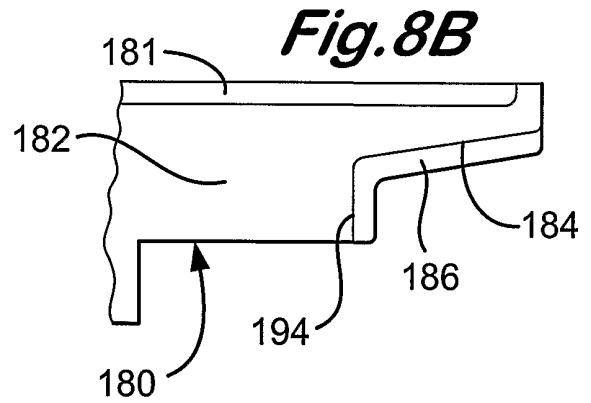
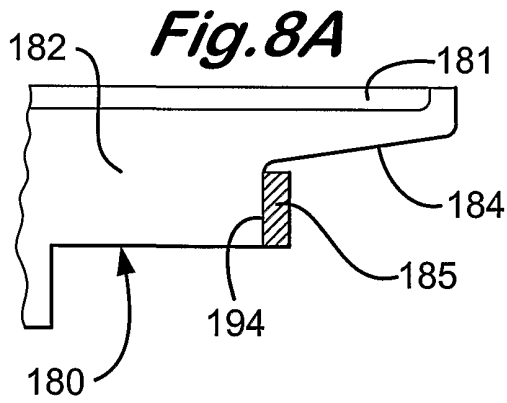
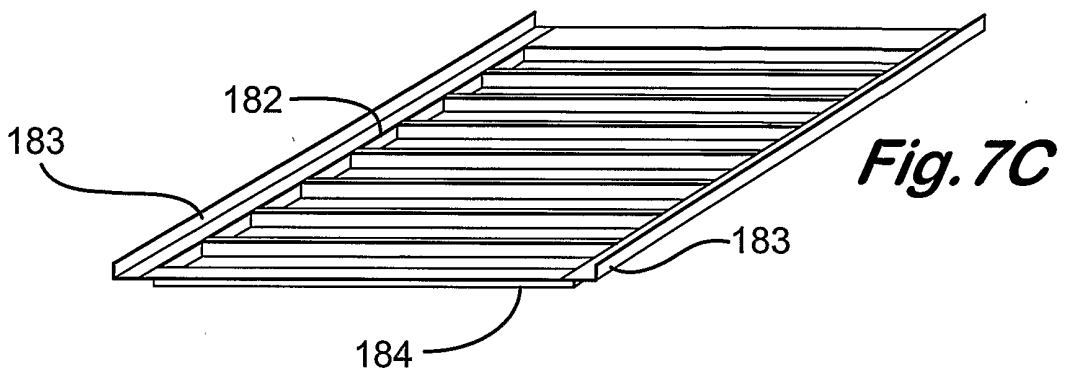
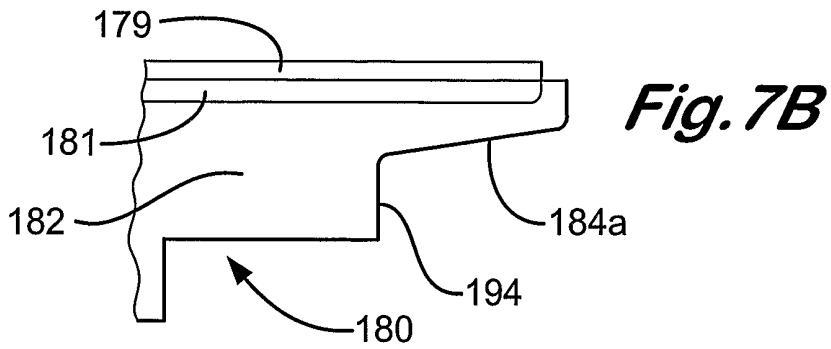

Fig. 8E

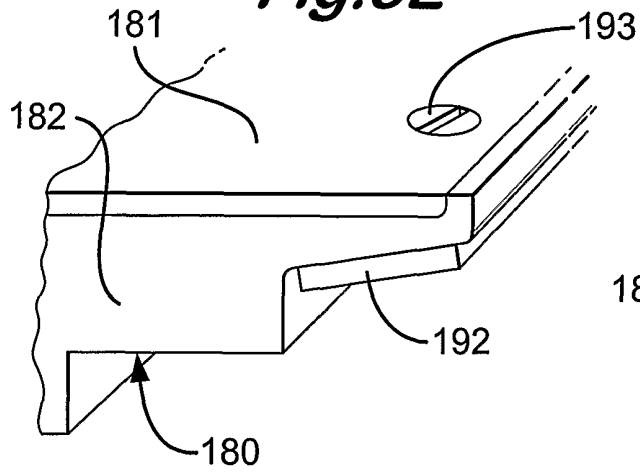

Fig. 8F

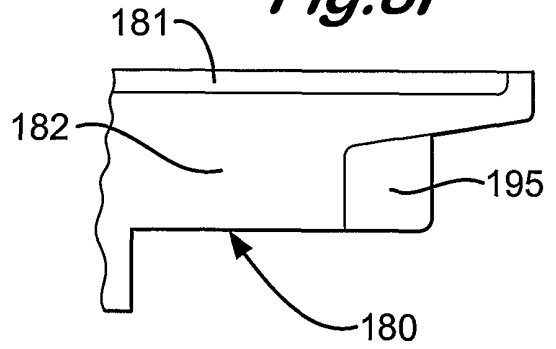

Fig. 8G

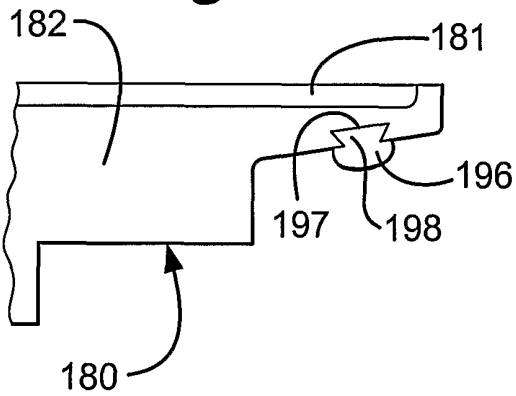

Fig. 8H

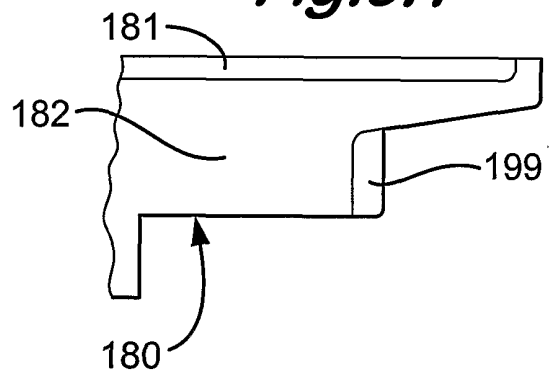

Fig. 8I

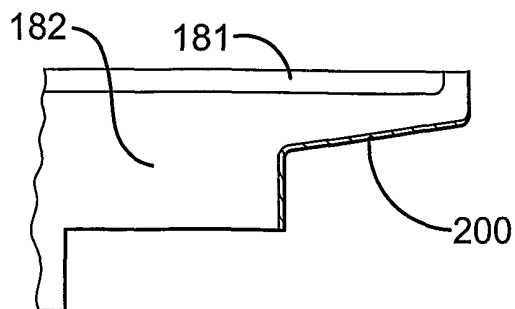
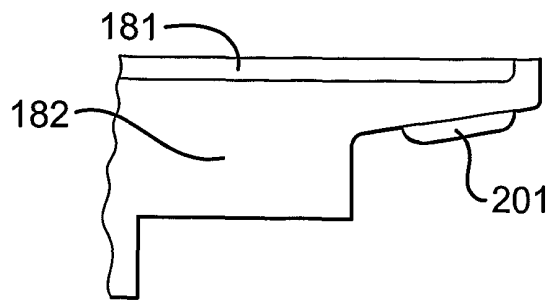
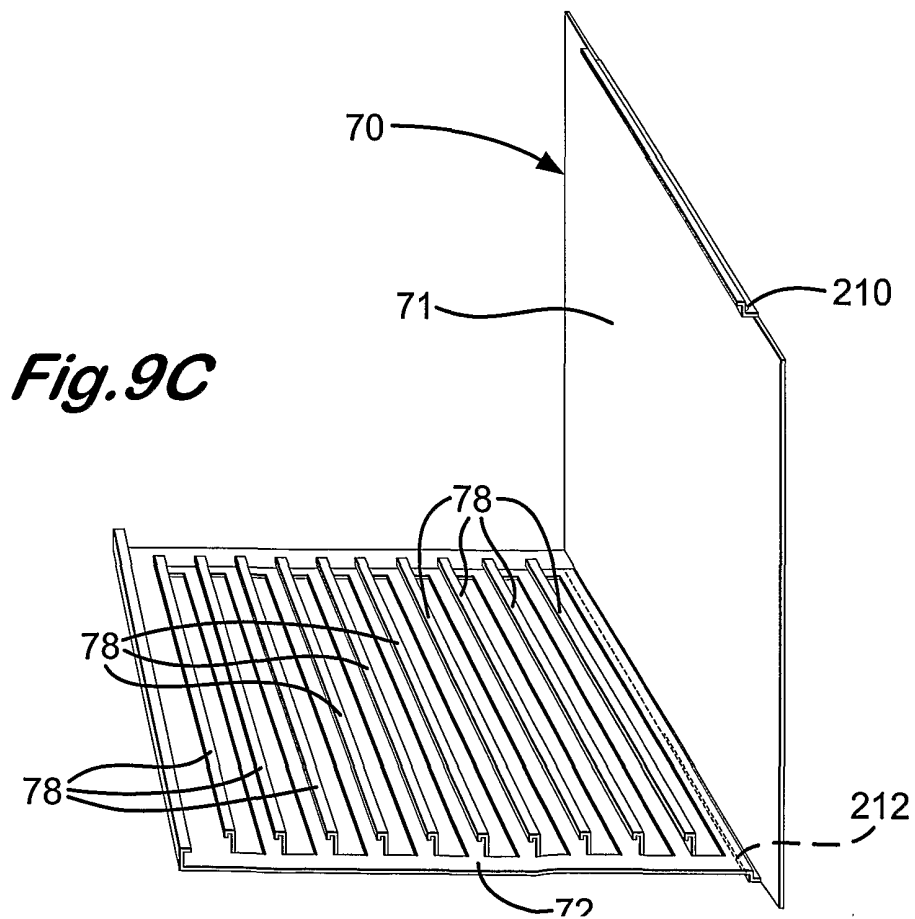
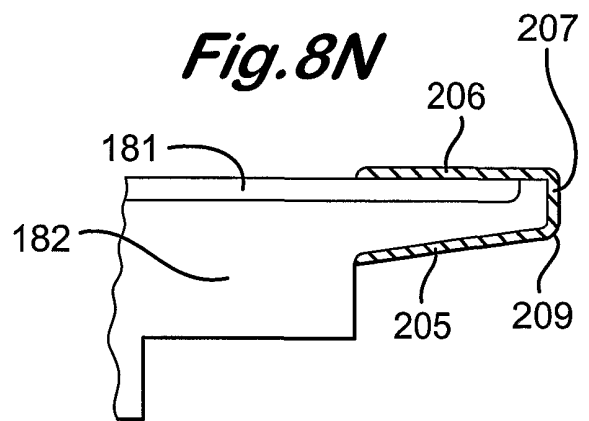
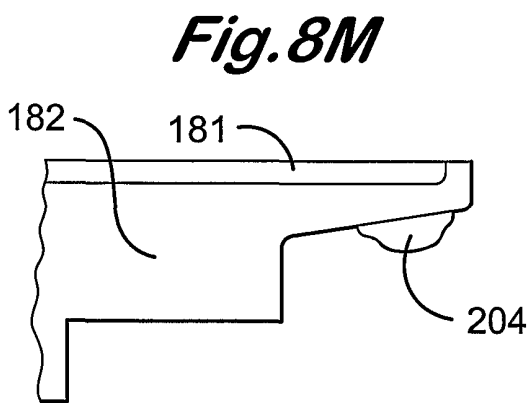
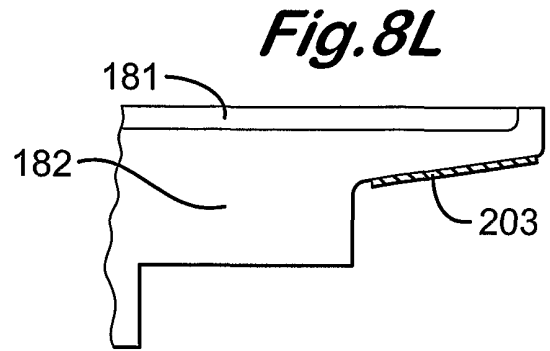
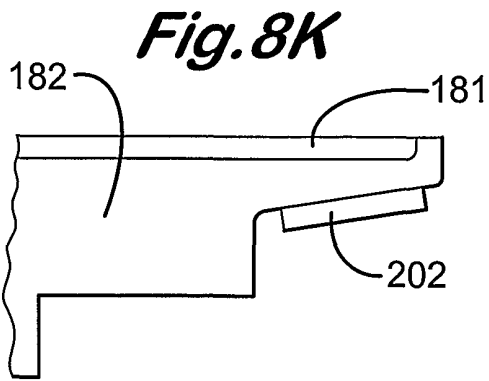

Fig. 8J





8/12

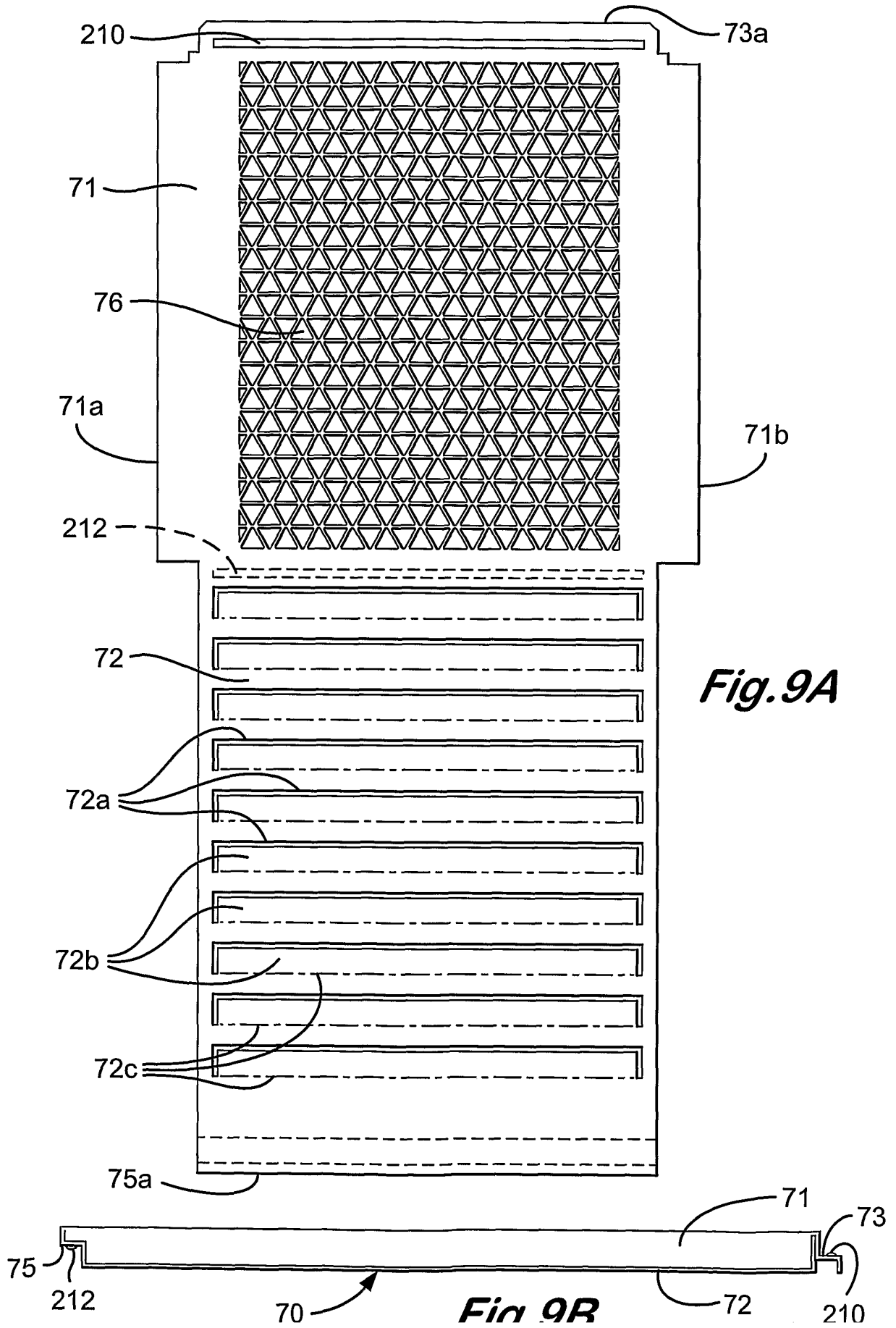
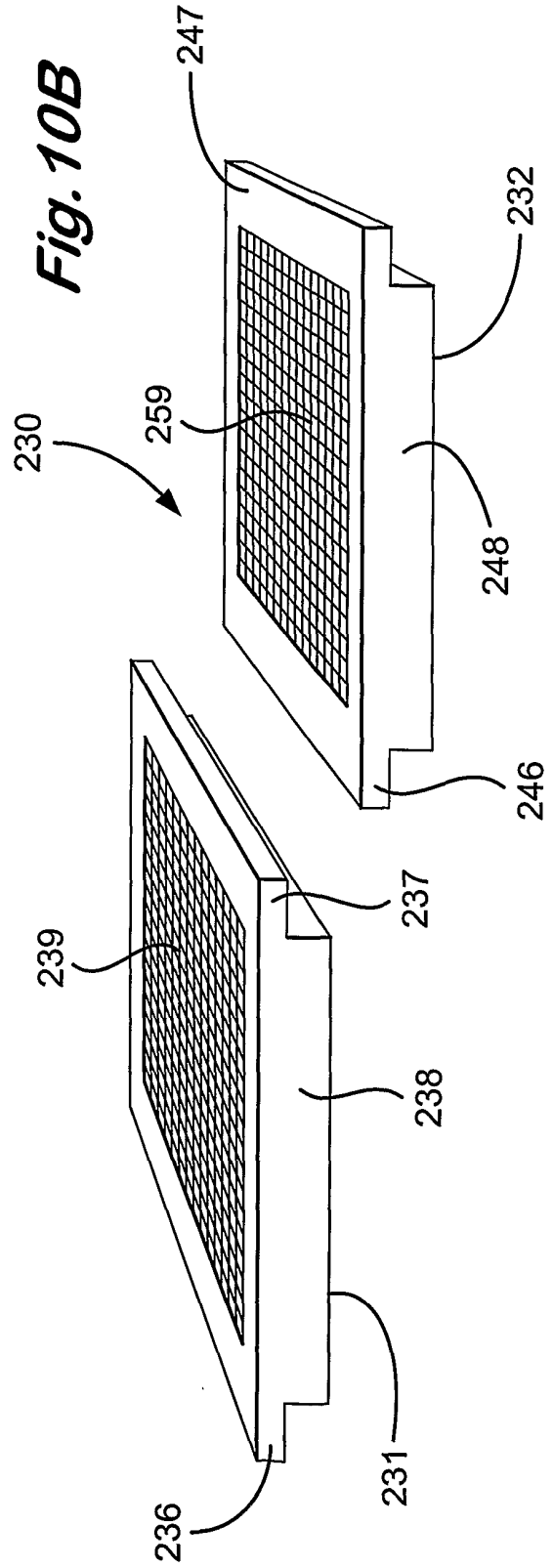
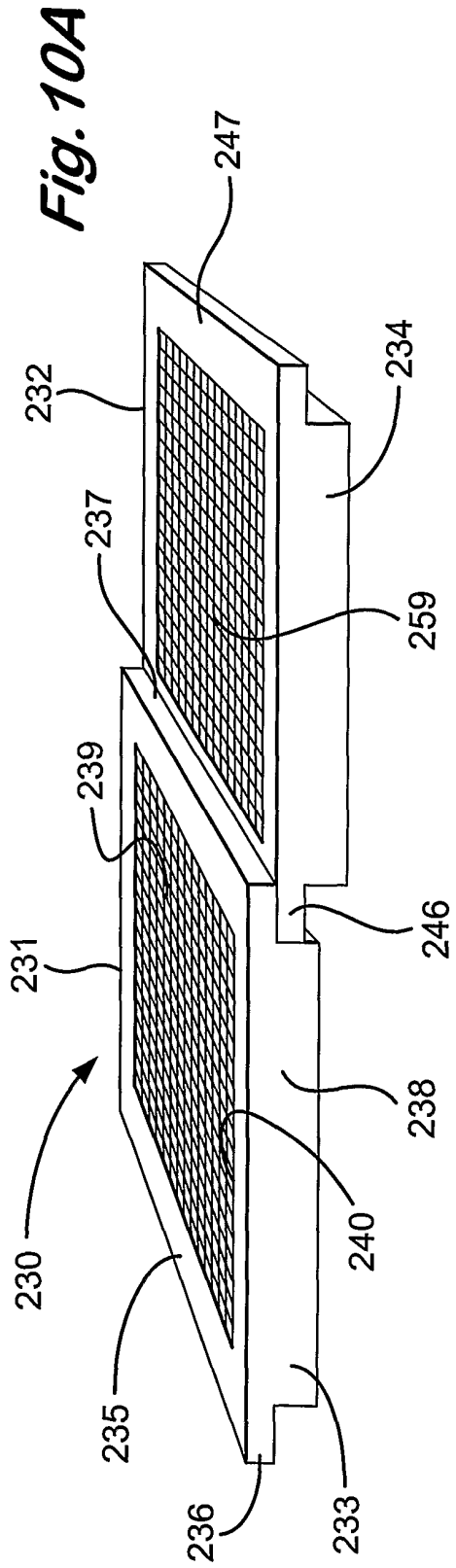

Fig. 9A

Fig. 9R



10/12

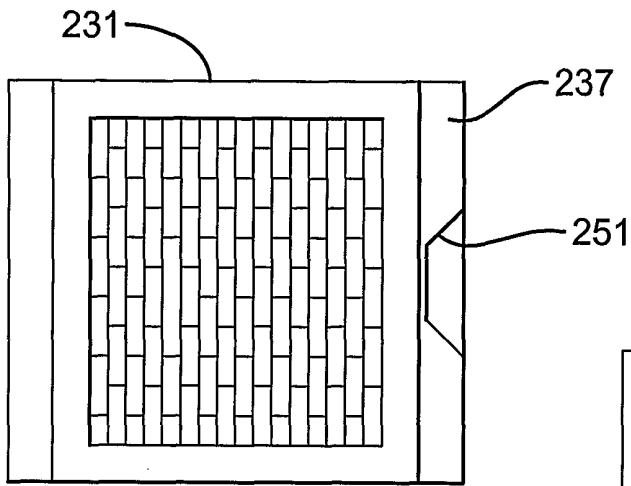

Fig. 10C

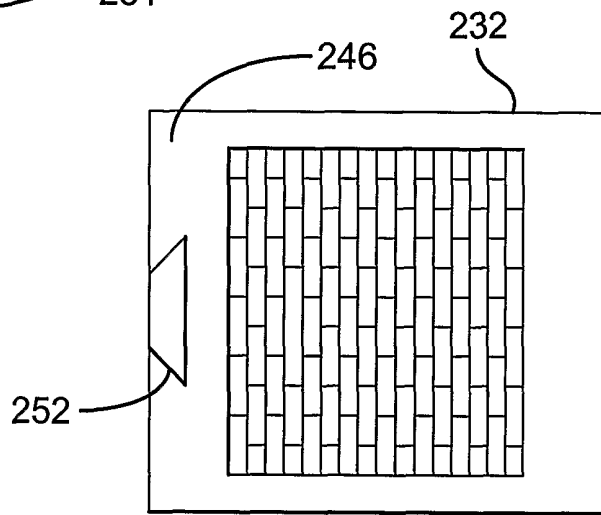

Fig. 10D

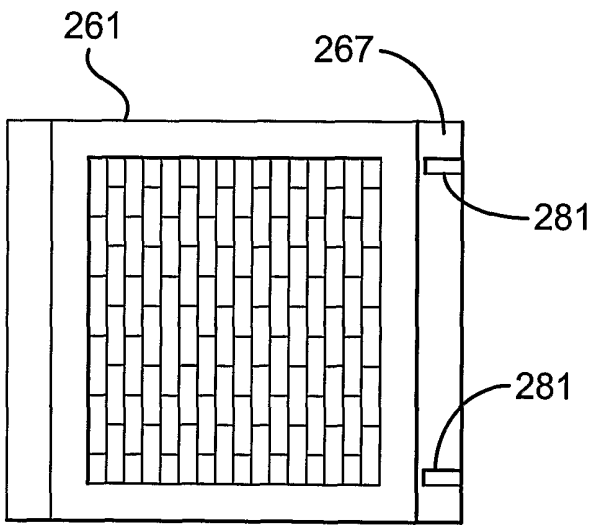

Fig. 11D

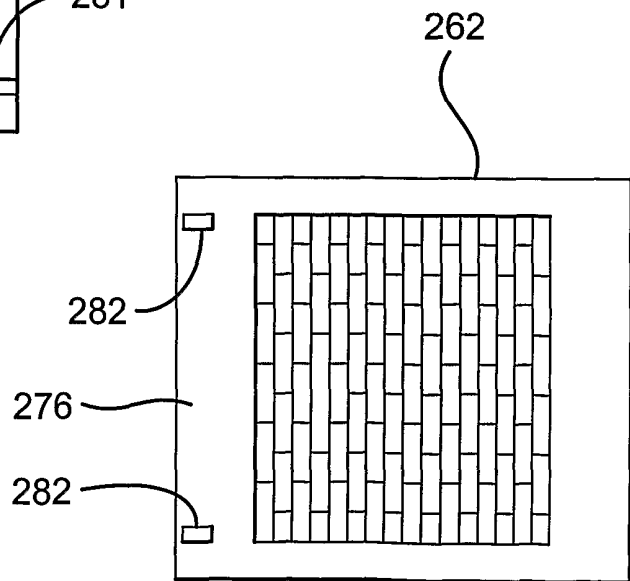

Fig. 11E

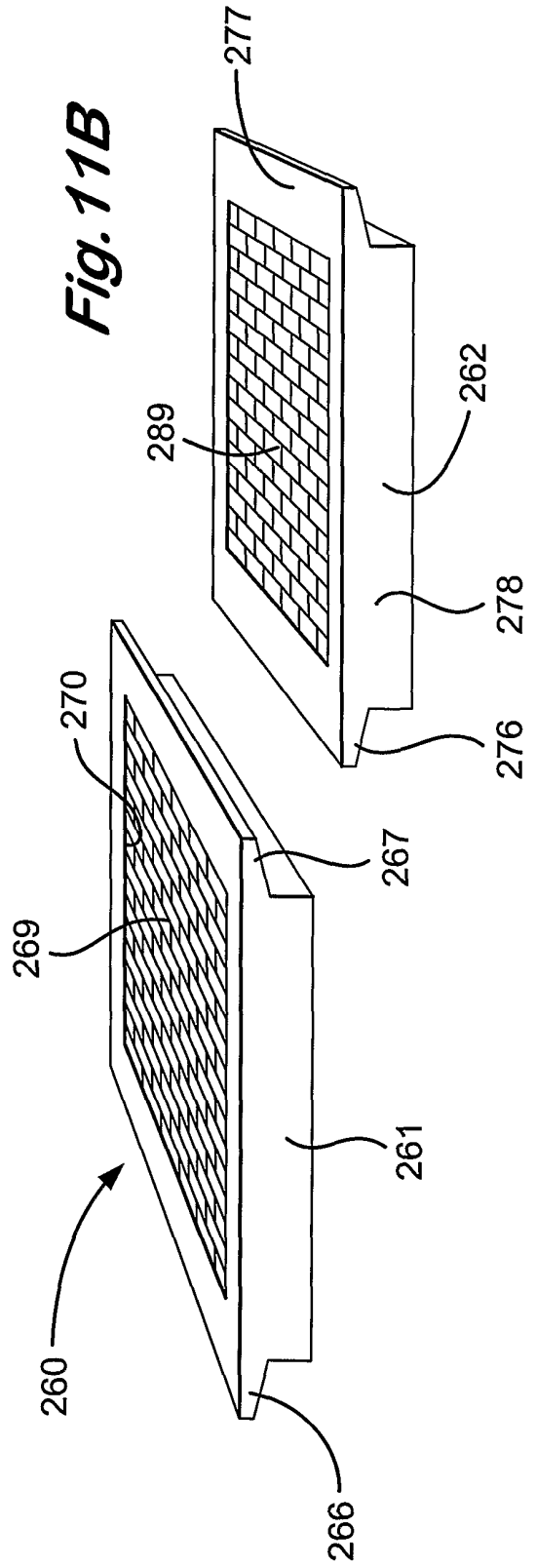
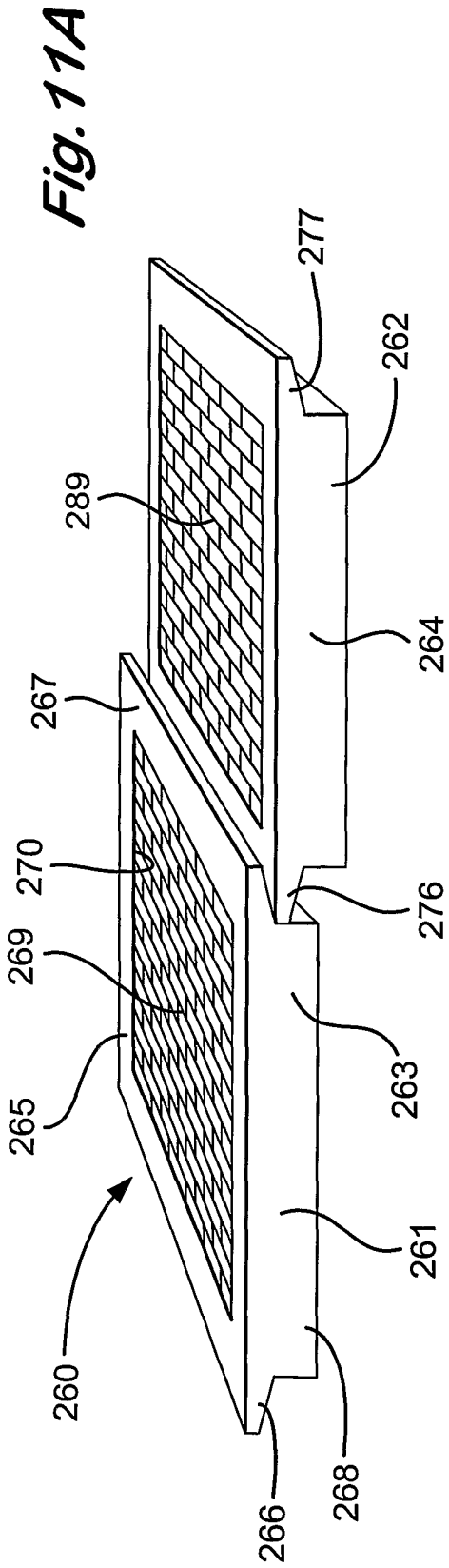
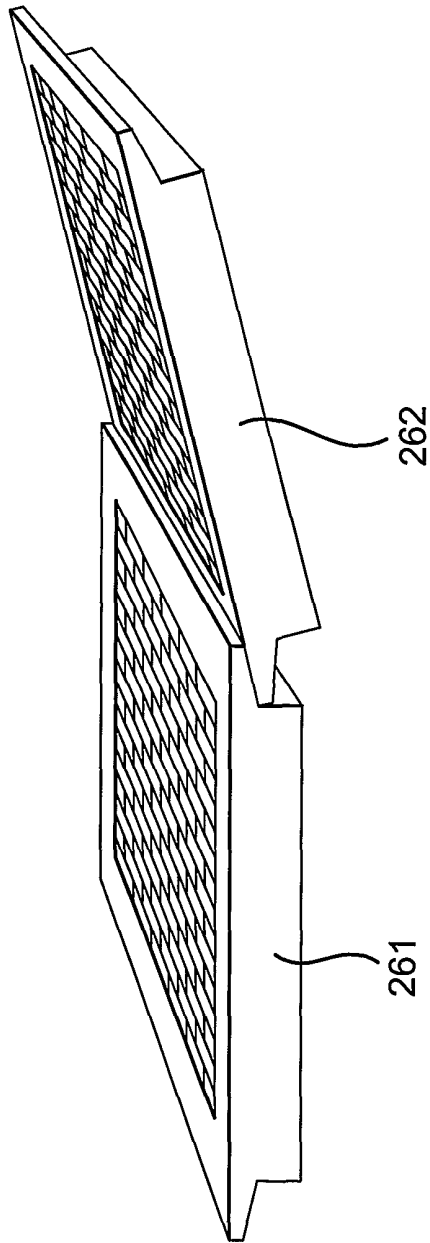

Fig. 11C



INTERNATIONAL SEARCH REPORT

International Application No
PCT/GB 01/02000

A. CLASSIFICATION OF SUBJECT MATTER
IPC 7 B01D33/03 B07B1/46

According to International Patent Classification (IPC) or to both national classification and IPC

B. FIELDS SEARCHED
Minimum documentation searched (classification system followed by classification symbols)
IPC 7 B01D B07B

Documentation searched other than minimum documentation to the extent that such documents are included in the fields searched

Electronic data base consulted during the international search (name of data base and, where practical, search terms used)
EPO-Internal

C. DOCUMENTS CONSIDERED TO BE RELEVANT

Category *	Citation of document, with indication, where appropriate, of the relevant passages	Relevant to claim No.
X	GB 2 206 501 A (THULE UNITED LTD) 11 January 1989 (1989-01-11) cited in the application the whole document ---	1-3, 12, 14-17
X	WO 84 02290 A (FIORIS PTY LTD) 21 June 1984 (1984-06-21) page 3, line 6 - line 12; claim 2; figures 1,5 ---	1-3, 14
X	WO 98 37988 A (COOK GORDON JAMES ; HUGHES ANDREW (GB); STEWART DUGALD (GB); UNITED) 3 September 1998 (1998-09-03) figures 6-10, 18 ---	1-3, 14-17
	-/--	

Further documents are listed in the continuation of box C. Patent family members are listed in annex.

* Special categories of cited documents :

A document defining the general state of the art which is not considered to be of particular relevance	*T* later document published after the international filing date or priority date and not in conflict with the application but cited to understand the principle or theory underlying the invention
E earlier document but published on or after the international filing date	*X* document of particular relevance; the claimed invention cannot be considered novel or cannot be considered to involve an inventive step when the document is taken alone
L document which may throw doubts on priority claim(s) or which is cited to establish the publication date of another citation or other special reason (as specified)	*Y* document of particular relevance; the claimed invention cannot be considered to involve an inventive step when the document is combined with one or more other such documents, such combination being obvious to a person skilled in the art.
O document referring to an oral disclosure, use, exhibition or other means	*Z* document member of the same patent family
P document published prior to the international filing date but later than the priority date claimed	

Date of the actual completion of the international search 31 October 2001	Date of mailing of the international search report 14/11/2001
----------------------------------------------------------------------------------	----------------------------------------------------------------------

Name and mailing address of the ISA European Patent Office, P.B. 5818 Patentlaan 2 NL - 2280 HV Rijswijk Tel. (+31-70) 340-2040, Tx. 31 651 epo nl, Fax: (+31-70) 340-3016	Authorized officer Hild, U
----------------------------------------------------------------------------------------------------------------------------------------------------------------------------------------	-----------------------------------

INTERNATIONAL SEARCH REPORT

International Application No
PCT/GB 01/02000

C.(Continuation) DOCUMENTS CONSIDERED TO BE RELEVANT		
Category °	Citation of document, with indication, where appropriate, of the relevant passages	Relevant to claim No.
X	WO 96 04060 A (ENVIRONMENTAL PROCEDURES INC ;LUCAS BRIAN RONALD (GB); LEONE VINCE) 15 February 1996 (1996-02-15) claims 1,2,9,11; figure 5 -----	1,2,13, 15-17
X	WO 96 11070 A (SVEDALA TRELLEX AB ;MALMBERG MATS ANDERS (SE)) 18 April 1996 (1996-04-18) page 7, line 8 - line 27; figures 1,2 -----	34,35
A	US 5 137 622 A (SOUTER GEORGE L) 11 August 1992 (1992-08-11) column 2, line 39 - line 42 -----	1,2,13
E	WO 01 76719 A (LUCAS BRIAN RONALD ;ADAMS THOMAS COLE (US); LARGENT DAVID WAYNE (U) 18 October 2001 (2001-10-18) page 8, line 11 -page 9, line 28; figures 5A-5E -----	18-33

INTERNATIONAL SEARCH REPORT
Information on patent family members

International Application No
PCT/GB 01/02000

Patent document cited in search report		Publication date	Patent family member(s)	Publication date
GB 2206501	A	11-01-1989	NONE	
WO 8402290	A	21-06-1984	AU 2100983 A WO 8402290 A1 CA 1225968 A1 DE 3390381 T FR 2537463 A1 GB 2141361 A ,B US 4661245 A ZA 8308477 A	14-06-1984 21-06-1984 25-08-1987 07-02-1985 15-06-1984 19-12-1984 28-04-1987 24-12-1984
WO 9837988	A	03-09-1998	AU 724886 B2 AU 6304498 A BR 9807644 A EP 0963261 A1 WO 9837988 A1 GB 2322590 A ,B GB 2337019 A ,B JP 2001513020 T NO 994245 A	05-10-2000 18-09-1998 22-02-2000 15-12-1999 03-09-1998 02-09-1998 10-11-1999 28-08-2001 01-09-1999
WO 9604060	A	15-02-1996	US 5551575 A AT 185281 T AU 2924595 A CA 2195207 A1 DE 69512668 D1 DK 773822 T3 WO 9604060 A1 EP 0773822 A1 NO 965435 A	03-09-1996 15-10-1999 04-03-1996 15-02-1996 11-11-1999 27-12-1999 15-02-1996 21-05-1997 20-01-1997
WO 9611070	A	18-04-1996	EP 0710509 A1 AU 3691895 A CA 2201903 A1 CN 1159776 A ,B DE 69415811 D1 DE 69415811 T2 WO 9611070 A1 US 5735409 A ZA 9508390 A	08-05-1996 02-05-1996 18-04-1996 17-09-1997 18-02-1999 10-06-1999 18-04-1996 07-04-1998 24-04-1996
US 5137622	A	11-08-1992	NONE	
WO 0176719	A	18-10-2001	US 6283302 B1 WO 0176719 A2	04-09-2001 18-10-2001