

(19)



(11)

EP 2 607 616 A1

(12)

EUROPEAN PATENT APPLICATION

(43) Date of publication:
26.06.2013 Bulletin 2013/26

(51) Int Cl.:
E21B 34/14^(2006.01) E21B 43/12^(2006.01)
E21B 43/14^(2006.01)

(21) Application number: **11195580.3**

(22) Date of filing: **23.12.2011**

(84) Designated Contracting States:
AL AT BE BG CH CY CZ DE DK EE ES FI FR GB GR HR HU IE IS IT LI LT LU LV MC MK MT NL NO PL PT RO RS SE SI SK SM TR
Designated Extension States:
BA ME

(72) Inventor: **Hallundbaek, Jørgen**
3230 Græsted (DK)

(74) Representative: **Hoffmann Dragsted A/S**
Rådhuspladsen 16
1550 Copenhagen V (DK)

(71) Applicant: **Welltec A/S**
3450 Allerød (DK)

(54) Production system for producing hydrocarbons from a well

(57) The present invention relates to a production system (1) for producing hydrocarbons from a well (2). Said production system comprises a production casing (3), a monitoring unit adapted to measure a production outcome of the well, a first reservoir zone (6) comprising at least a first fluid (10), extending along and outside part of the production casing, a second reservoir zone (7) comprising at least a second fluid (11), extending along and outside another part of the production casing, a first inflow device (8) arranged in the first reservoir zone having a first inflow area and being adapted to let the first fluid into the production casing at a first volume rate (V1),

a second inflow device (9) arranged in the second reservoir zone having a second inflow area and being adapted to let the second fluid into the production casing at a second volume rate (V2), wherein the first and second inflow areas of the inflow devices are adjustable, whereby the first and second inflow devices can be adjusted so that the first volume rate is equal to or higher than the second volume rate. Furthermore, the present invention relates to a well completion comprising the production system according to the invention as well as to a production method for the production of hydrocarbons from a well.

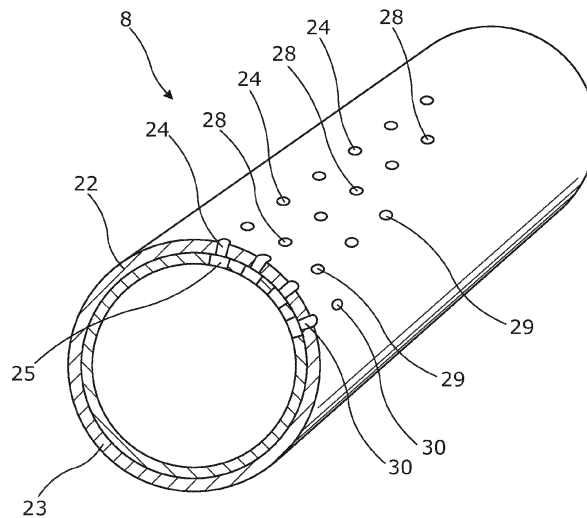

Fig. 7

EP 2 607 616 A1

Description

Field of the invention

[0001] The present invention relates to a production system for producing hydrocarbons from a well. Furthermore, the present invention relates to a well completion comprising the production system according to the invention as well as to a production method for the production of hydrocarbons from a well.

Background art

[0002] During oil and gas production, it is sometimes necessary to assist the production in a well due to a high hydro-static pressure. If the well itself is not capable of generating the adequate pressure to drive oil or gas to the surface, or the well has been deliberately killed, artificial lift may be used to lift the well fluid at the upper part of the well.

[0003] By submerging a pump in a well, the pump may be used to boost the pressure or perhaps restart a dead well. The pump sets a plug or seal in the well and pumps well fluid from one side of the plug to the other to overcome the static pressure of the well fluid above the pump.

[0004] Other methods of artificial lift use chemicals or gasses to provide the lift required to ensure an acceptable production outcome from the well. However, the known solutions overcoming the static pressure of the well fluid use external energy sources.

Summary of the invention

[0005] It is an object of the present invention to wholly or partly overcome the above disadvantages and drawbacks of the prior art. More specifically, it is an object to provide an improved production system for producing hydrocarbons from a well without using artificial lift system, such as a pump, gas, or chemicals.

[0006] The above objects, together with numerous other objects, advantages, and features, which will become evident from the below description, are accomplished by a solution in accordance with the present invention by a production system for producing hydrocarbons from a well, comprising

- a production casing,
- a monitoring unit adapted to measure a production outcome of the well,
- a first reservoir zone comprising at least a first fluid, extending along and outside part of the production casing,
- a second reservoir zone comprising at least a second fluid, extending along and outside another part of the production casing,
- a first inflow device arranged in the first reservoir zone having a first inflow area and being adapted to let the first fluid into the production casing at a first

volume rate,

- a second inflow device arranged in the second reservoir zone having a second inflow area and being adapted to let the second fluid into the production casing at a second volume rate,

wherein the first and second inflow areas of the inflow devices are adjustable, whereby the first and second inflow devices can be adjusted so that the first volume rate is equal to or higher than the second volume rate.

[0007] Hereby, a production system is obtained wherein the energy present in reservoir and well is used to lifting the well fluid up from the well, substantially without the use of external energy sources.

[0008] Moreover, the inflow area may be constituted by a plurality of inflow openings, each having an opening area.

[0009] Said inflow openings may be arranged in rows along the inflow device.

[0010] Further, the inflow device may comprise a first outer sleeve and a second inner sleeve movable in relation to each other, the first outer sleeve having outer inflow openings arranged in rows with a different number of openings in each row, and the second inner sleeve having inner openings, the inner openings being arranged with a distance between them in relation to the outer openings, whereby the inner openings of the second inner sleeve can be moved and aligned in relation to the outer openings of the first sleeve so that the inflow area of the inflow device is adjustable.

[0011] Additionally, the inner openings of the inner sleeve may be arranged with predetermined distances between them so that each row of outer inflow openings can optionally be opened or closed by moving the inner sleeve.

[0012] In one embodiment, the inner sleeve may be rotatably movable in relation to the outer sleeve.

[0013] In another embodiment, the inner sleeve may be slidably movable in relation to the outer sleeve.

[0014] In addition, the monitoring unit may be adapted to measure a water content of the production outcome so that the inflow devices may be adjusted, whereby an optimum between production outcome and water content is obtained.

[0015] The production system as described above may further comprise a monitoring unit adapted to measure a production outcome of the well.

[0016] Also, the monitoring unit may be adapted to measure a volume rate of the production outcome and/or a pressure at the top of the well so that the inflow devices may be adjusted in view of volume rate and/or pressure measured at the top of the well.

[0017] In one embodiment, the inflow devices may be manually adjustable.

[0018] In another embodiment, the inflow devices may be remotely adjustable.

[0019] Furthermore, the inflow device may be operated by a magnetic source.

[0020] Moreover, the reservoir zones may be separated by annular barriers.

[0021] In an embodiment, the system may comprise a plurality of reservoir zones.

[0022] Further, a plurality of inflow devices may be arranged in the system and/or in each reservoir zone.

[0023] Said plurality of inflow devices may be arranged in the system and/or in each reservoir zone.

[0024] Also, the first fluid may be oil and the second fluid may be water or gas.

[0025] In addition, a valve may be arranged in one or more of the openings.

[0026] Furthermore, a screen may be arranged outside the openings.

[0027] The present invention also relates to a well completion comprising the production system as described above.

[0028] Further, the present invention relates to a production method for the production of hydrocarbons from a well, comprising the steps of

- determining a first reservoir zone comprising at least a first fluid,
- determining a second reservoir zone comprising at least a second fluid,
- opening a first inflow device in the first zone to let the at least first fluid into a production casing at a first volume rate,
- opening a second inflow device in the second zone to let the at least second fluid into the production casing at a second volume rate,
- monitoring a production outcome of the well, and
- adjusting the first and second inflow devices in view of the production outcome so that the first volume rate is equal to or higher than the second volume rate.

[0029] In said method, the monitoring step may comprise one or more of the steps of:

- measuring a pressure at the top of the well,
- measuring a volume rate of the production outcome at the top of the well, or
- measuring a water content of the production outcome at the top of the well.

[0030] Also, the adjusting step may comprise adjustment of at least one of the inflow devices on the basis of the measured pressure, volume rate and/or water content at the top of the well.

[0031] Moreover, the step of adjusting may be performed manually, for instance by a key tool connected with a downhole tractor.

[0032] Additionally, the step of adjusting may be performed remotely from the top of the well.

[0033] Finally, the step of adjusting may be performed wirelessly.

Brief description of the drawings

[0034] The invention and its many advantages will be described in more detail below with reference to the accompanying schematic drawings, which for the purpose of illustration show some non-limiting embodiments and in which

Fig. 1 shows a production system according to one embodiment of the invention,

Fig. 2 shows another embodiment of the production system having a plurality of reservoir zones,

Fig. 3 shows a diagram of volume rate in relation to pressure,

Fig. 4 shows, in a cross-sectional view, an embodiment of an inflow device,

Fig. 5 shows, in a cross-sectional view, another embodiment of an inflow device,

Fig. 6 shows, in a cross-sectional view, an additional embodiment of an inflow device,

Fig. 7 shows, partly in a cross-sectional view and partly in perspective, the inflow device of Fig. 4,

Figs. 8a-8o show, in cross-sectional views, different positions of the inflow device of Figs. 4 and 7 in relation to the volume rate, and

Fig. 9 shows, in cross-sectional view, the inflow device of Fig. 6.

[0035] All the figures are highly schematic and not necessarily to scale, and they show only those parts which are necessary in order to elucidate the invention, other parts being omitted or merely suggested.

Detailed description of the invention

[0036] Fig. 1 shows a production system 1 for producing hydrocarbons from a well 2. The production system 1 comprises a production casing 3 extending along the well 2. The production system 1 furthermore comprises a monitoring unit 4 adapted to measure a production outcome of the well 2. In this embodiment, the monitoring unit is positioned at the top of the well 2, i.e. at the well-head 5. The monitoring unit may comprise a flow measuring device, a pressure sensor, a water cut measuring device, or a combination thereof.

[0037] The production system 1 also comprises a first reservoir zone 6 comprising at least a first fluid 10, extending along and outside the production casing 3, and a second reservoir zone 7 comprising at least a second fluid 11, extending along and outside the production cas-

ing. Furthermore, a first inflow device 8 is arranged in the first reservoir zone 6 having a first inflow area and being adapted to let the first fluid 10 into the production casing 3 at a first volume rate V1, and a second inflow device 9 is arranged in the second reservoir zone 7 having a second inflow area and being adapted to let the second fluid 11 into the production casing 3 at a second volume rate V2. The first and second inflow areas of the inflow devices 8, 9 are adjustable, whereby the first and second inflow devices 8, 9 can be adjusted in view of the production outcome so that the first volume rate V1 is equal to or higher than the second volume rate V2. Hereby is obtained that the production of hydrocarbons from the well 2 may be optimised by adjusting the inflow volume rates of the inflow devices 8, 9 to the instantaneous requirement in view of the either the volume rate of the production outcome, the pressure at the top of the well 2, the water content of the production outcome, or a combination thereof. Thus, by means of the present system it is possible to create lift of the fluids in the well by adjusting the inflow volume rates of the fluids into the production casing 3 and thereby avoid the use of artificial lift or at least substantially reduce the use of artificial lift.

[0038] In the production system 1 shown in Fig. 1, the first and second reservoir zones 6, 7 are adjacent zones, and they are separated from each other by expandable annular barriers 12. In the embodiment shown in Fig. 1, the first fluid 10 present in the first reservoir zone 6 is essentially oil and the second fluid 11 present in the second reservoir zone 7 is essentially water. In this embodiment, the first and second reservoir zones 6, 7 each has a reservoir pressure of 300 bar. The first inflow device 8 of the first reservoir zone 6 is adjusted to let in the first fluid 10, i.e. oil, so that a pressure of 200 bar is present in the production casing 3. Thereby, a pressure difference of 100 bar exists between the reservoir and the casing. The second inflow device 9 of the second reservoir zone 7 is adjusted to let in the second fluid 11, i.e. water, so that a pressure of 250 bar is present in the production casing 3 (the 200 bar from the first zone and 50 bar from the second zone). Thereby a pressure difference of 50 bar exists between the reservoir at the second zone and the production casing. By letting in the second fluid 11, i.e. water, a higher water content is present in the production outcome. However, a higher volume rate of the production outcome as well as enhanced lift to the well is achieved. In fact, the energy present in the reservoir is utilised to lift the well instead of using secondary means, such as an artificial lift by means of gas, or adding chemicals for providing lift.

[0039] In Fig. 2, another embodiment of the production system 1 is shown. In this embodiment, the production system 1 has five reservoir zones 6, 7, 13, 14, 15, mutually separated by expandable annular barriers 12. In Fig. 2, the first and second reservoir zones 6, 7 are separated by another reservoir zone 14 having a third fluid 10a with a lower oil content than the first fluid 11. Below the first zone 6, another reservoir zone 13 is present hav-

ing a fourth fluid 10b which also has a lower oil content than the first fluid 11, and above the second zone 7, a fifth zone 15 is present having a fourth fluid 11a with a lower water content than the second fluid 10. Furthermore, one or more of the additional inflow devices 16, 17, 18 arranged in the other reservoir zones 13, 14, 15, respectively, may also be adjusted to let in fluid at certain volume rates to the production rate for enhancing the lift in the well as well as for providing an optimum production outcome. Thus, the production system 1 may function in the same manner as described in relation to Fig. 1.

[0040] Fig. 3 shows a diagram disclosing different relationships between volume rate of the production outcome and pressure. As an example, the diagram has three different curves, 19, 20, 21, each representing varying volume rates at a certain pressure. In the example above from Fig. 1, the first inflow device 8 is positioned to a high volume rate at a pressure lower than that of the second inflow device 9, and the fluid therethrough would therefore follow curve 20. The second device 9 is positioned at a lower volume rate but at a higher pressure, and the fluid therethrough will therefore be positioned on curve 21 but not at such a high volume rate as the fluid through the first inflow device 8. From the diagram, it is deducible that a high pressure and a high volume rate, cf. curve 21, provide a high production outcome.

[0041] Fig. 4 shows a cross-sectional view of the inflow device 8. This view is taken along an axial extension of the inflow device 8 being concentric with the axial extension of the casing. In this embodiment, the inflow device 8 comprises an outer sleeve 22 and an inner sleeve 23, and the inner sleeve 23 may be movable in relation to the outer sleeve 22. The cross-sectional view is taken along a row of inflow openings 24 arranged in the extension of the inflow device 8. In this row there are 7 inflow openings 24. The inflow area of the inflow device is *inter alia* constituted by these inflow openings 24, each having an opening area. If the inflow device 8 has several rows of inflow openings, it is the total opening area of all rows which provide the available total inflow area of the inflow device. The inflow openings 24 are in fluid connection with the inner opening 25 of the second inner sleeve 23 so that fluid from the reservoir may flow in through the inflow device 8. In this embodiment, the inner opening 25 is shown as a through-going groove, which extends in the axial extension of the inflow device 8. The inner opening 25 has a larger extension than the inflow openings 24 so as to obtain that the inner opening 25, when being aligned with the inflow openings, does not hinder the flow of fluid. A screen 26 or filter is arranged on the outside of the inflow openings.

[0042] Another embodiment of the inflow device 8 is shown in Fig. 5 in a cross-sectional view. Again this view is taken along an axial extension of the inflow device 8. The inflow device 8 also comprises an outer sleeve 22 and an inner sleeve 23 being movable in relation to each other. The inflow openings 24 are in fluid connection with the inner openings 25 of the second inner sleeve 23 so

that fluid from the reservoir may flow in through the inflow device 8. In this embodiment, the inner openings 25 are shown as 7 through-going holes which may be aligned with inflow openings 24. The inner openings 25 have a larger extension than each of the inflow openings 24 so they do not hinder the flow of fluid. Again a screen 26 or filter is arranged on the outside of the inflow openings 24.

[0043] An additional embodiment of the inflow device 8 is shown in Fig. 6 in a cross-sectional view, taken along a row of inflow openings 24 arranged in the extension of the inflow device 8. The inflow openings 24 terminate in an axially extending channel 27 arranged in the wall of the outer sleeve 22. The axial channel 27 abuts an axial channel 55 arranged in the inner sleeve 23, whereby the inflow openings 24 is in fluid communication with the inner opening 25 via the two axial channels 27, 55, respectively. Also, in this embodiment a screen 26 or filter is arranged on the outside of the inflow openings 24. The embodiment of the inflow device 8 shown in Fig. 6 will be described further in connection with Fig. 9 below.

[0044] The inflow device 8 of Fig. 4 is shown in perspective in Fig. 7. The inflow device 8 comprises an outer sleeve 22 and an inner sleeve 23, wherein the inner sleeve 23 is movable in relation to the outer sleeve 22 by rotation. In this embodiment of the inflow device 8, four rows of inflow openings 24, 28, 29, 30 are arranged adjacent to each other and along the axial extension of the inflow device 8. The first row has seven inflow openings 24 shown in the cross-sectional view in Fig. 4. The second row has six inflow openings 28. The third row has four inflow openings 29 and the fourth row has two inflow openings 30. In this embodiment, the inflow openings 24, 28, 29, 30 of the four rows constitute the inflow area of the inflow device 8.

[0045] In other embodiments, the inflow device may have a different number of rows as well as a different number of inflow openings in each row. Thus, the embodiment shown in Fig. 7 is one configuration of the inflow device 8.

[0046] In this embodiment, the inner sleeve 23 is shown with four inner openings 25, all aligned with each row of inflow openings arranged in the outer sleeve 22. Also, the inflow device 8 may have a different number of inner openings, as well as different positions along the periphery of the inner sleeve.

[0047] In Figs. 8a to 8o, a sequence of different adjustments to a different position of the inflow device 8 in relation to the desired inflow volume rate of the inflow device 8 is shown.

[0048] As above, the inflow device 8 comprises an inner sleeve 23 or tubular which is rotatable within the outer sleeve 22 or tubular. The inflow device 8 is shown in a cross-sectional view taken in a radial extension of the inflow device 8. The outer sleeve 22 has four rows of inflow openings, 24, 28, 29, 30. In the first row 24 there are seven inflow openings as shown in Fig. 7, and in the second row 28 there are six openings, in the third row 29 there are four openings, and in the fourth row there are

two openings. In this embodiment, the inner sleeve 23 has ten inner openings 25, 31, 32, 33, 34, 35, 36, 37, 38, 39 in the form of grooves, as shown in Fig. 4, arranged along the periphery of the inner sleeve 23. The inner openings 25, 31, 32, 33, 34, 35, 36, 37, 38, 39 are arranged with predetermined distances between them so that each row of the outer inflow openings 24 can optionally be opened or closed by rotating the inner sleeve 23, which will be further described below.

[0049] In Fig. 8a, the rows of inflow openings 24, 28, 29, 30 are all aligned with the inner openings 31, 32, 33, 34 of the inner sleeve 23. Thus, in Fig. 8a, all inflow openings 24, 28, 29, 30 of the inflow device 8 are open, whereby fluid may flow through all nineteen openings. This is the maximum flow capacity of the inflow device 8.

[0050] In Fig. 8b, the inner sleeve 23 is rotated slightly to the right, whereby the inner opening 25 is aligned with the first row of inflow openings 24, the inner opening 31 is aligned with the row of inflow openings 29, and the inner opening 32 is aligned with the row of inflow openings 30. Thus, in this adjustment of the inflow device 8, the rows of inflow openings 24, 29, 30 are open and the row of inflow openings 28 is closed, resulting in thirteen openings opened. By rotating the inner sleeve even further, so that the inner opening 25 is aligned with the third row of inflow openings 29, four openings are open, and by rotating the inner sleeve even further, so that the inner opening 25 is aligned with the fourth row of inflow openings 30, two openings are open.

[0051] In Fig. 8c, the inner sleeve 23 is rotated slightly to the left, whereby the inner opening 31 is aligned with the row of inflow openings 28, the inner opening 32 is aligned with the row of inflow openings 29, and the inner opening 33 is aligned with the row of inflow openings 30. Thus, in this adjustment of the inflow device 8, the rows of inflow openings 28, 29, 30 are open and the row of inflow openings 24 is closed, resulting in twelve openings opened.

[0052] In Fig. 8d, the inner sleeve 23 is rotated slightly to the left in relation to the adjustment of Fig. 8c, whereby the inner opening 32 is aligned with the row of inflow openings 24, the inner opening 33 is aligned with the row of inflow openings 28, and the inner opening 34 is aligned with the row of inflow openings 29. Thus, in this adjustment of the inflow device 8, the rows of inflow openings 24, 28, 29 are open and the row of inflow openings 30 is closed, resulting in seventeen openings opened.

[0053] In Fig. 8e, the inner sleeve 23 is rotated slightly to the left in relation to the adjustment of Fig. 8d, whereby the inner opening 33 is aligned with the row of inflow openings 24, the inner opening 34 is aligned with the row of inflow openings 28, and the inner opening 35 is aligned with the row of inflow openings 30. Thus, in this adjustment of the inflow device 8, the rows of inflow openings 24, 28, 30 are open and the row of inflow openings 29 is closed, resulting in fifteen openings opened.

[0054] In Fig. 8f, the inner sleeve 23 is rotated slightly to the left in relation to the adjustment of Fig. 8e, whereby

the inner opening 34 is aligned with the row of inflow openings 24, and the inner opening 35 is aligned with the row of inflow openings 29. Thus, in this adjustment of the inflow device 8, the rows of inflow openings 24, 29 are open and the rows of inflow openings 28, 30 are closed, resulting in eleven openings opened.

[0055] In Fig. 8g, the inner sleeve 23 is rotated slightly to the left in relation to the adjustment of Fig. 8f, whereby the inner opening 35 is aligned with the row of inflow openings 28. Thus, in this adjustment of the inflow device 8, the row of inflow openings 28 are open and the rows of inflow openings 24, 29, 30 are closed, resulting in six openings opened.

[0056] In Fig. 8h, the inner sleeve 23 is rotated slightly to the left in relation to the adjustment of Fig. 8g, whereby the inner opening 35 is aligned with the row of inflow openings 24, and the inner opening 36 is aligned with the row of inflow openings 30. Thus, in this adjustment of the inflow device 8, the rows of inflow openings 24, 30 are open and the rows of inflow openings 28, 29 are closed, resulting in nine openings opened.

[0057] In Fig. 8i, the inner sleeve 23 is rotated slightly to the left in relation to the adjustment of Fig. 8h, whereby the inner opening 36 is aligned with the row of inflow openings 28, and the inner opening 37 is aligned with the row of inflow openings 30. Thus, in this adjustment of the inflow device 8, the rows of inflow openings 28, 30 are open and the rows of inflow openings 24, 29 are closed, resulting in eight openings opened.

[0058] In Fig. 8j, the inner sleeve 23 is rotated slightly to the left in relation to the adjustment of Fig. 8i, whereby the inner opening 36 is aligned with the row of inflow openings 24, and the inner opening 37 is aligned with the row of inflow openings 29. Thus, in this adjustment of the inflow device 8, the rows of inflow openings 24, 29 are open and the rows of inflow openings 28, 30 are closed, thus being the same position as in Fig. 8f.

[0059] In Fig. 8k, the inner sleeve 23 is rotated slightly to the left in relation to the adjustment of Fig. 8j, whereby the inner opening 38 is aligned with the row of inflow openings 29, and the inner opening 39 is aligned with the row of inflow openings 30. Thus, in this adjustment of the inflow device 8, the rows of inflow openings 29, 30 are open and the rows of inflow openings 24, 28 are closed, resulting in six openings opened.

[0060] In Fig. 8l, the inner sleeve 23 is rotated slightly to the left in relation to the adjustment of Fig. 8k, whereby the inner opening 38 is aligned with the row of inflow openings 28, and the inner opening 39 is aligned with the row of inflow openings 29. Thus, in this adjustment of the inflow device 8, the rows of inflow openings 28, 29 are open and the rows of inflow openings 24, 30 are closed, resulting in ten openings opened.

[0061] In Fig. 8m, the inner sleeve 23 is rotated slightly to the left in relation to the adjustment of Fig. 8l, whereby the inner opening 38 is aligned with the row of inflow openings 24, and the inner opening 39 is aligned with the row of inflow openings 28. Thus, in this adjustment

of the inflow device 8, the rows of inflow openings 24, 28 are open and the rows of inflow openings 29, 30 are closed, resulting in thirteen openings opened.

[0062] In Fig. 8n, the inner sleeve 23 is rotated slightly to the left in relation to the adjustment of Fig. 8m, whereby the inner opening 39 is aligned with the row of inflow openings 24. Thus, in this adjustment of the inflow device 8, the row of inflow openings 24 are open and the rows of inflow openings 28, 29, 30 are closed, resulting in seven openings opened.

[0063] In Fig. 8o the inner sleeve 23 is rotated slightly to the left in relation to the adjustment of Fig. 8n, whereby all rows of inflow openings 24, 28, 29, 30 are closed. Thus, in this adjustment the inflow device 8 is closed.

[0064] The sequence of adjustments shown in Figs. 8a to 8o shows different flow capacities of the inflow device 8, resulting in fourteen different volume rates. Even though some possible adjustments of the inflow device 8 are not shown in Figs. 8a to 8o, it is evident for the skilled person that the configuration of the inflow device 8 is capable of opening and closing all rows of inflow openings independently of each other by rotating the inner sleeve to the intended position.

[0065] Fig. 9 shows a longitudinal cross-sectional view of another embodiment of an inflow device 8. The inflow device 8 comprises a first sleeve or tubular 40 having twelve inflow openings 24 and a first wall 41 having twelve first axial channels 27 extending in the first wall 41 from the inflow openings 24. By axial channels is meant that the channels extend in an axial direction in relation to the inflow device 8.

[0066] The inflow device 1 also comprises a second sleeve 42 or tubular having a first end 43 and a second end 44 and, in this view, six inner openings 25. Even though the second sleeve 42 or tubular only shows six inner openings 25, the number of inner openings is actually the same as in the first sleeve 40 or tubular, i.e. 12 inner openings.

[0067] Furthermore, the second sleeve 42 or tubular is rotatable within the first sleeve 40 or tubular and has a second wall 45 having twelve second axial channels (not shown) extending in the second wall 45 from the first end 43 to the inner opening 25. Thus, each inner opening 25 has its own second axial channel.

[0068] The second sleeve 42 or tubular is arranged in an inner circumferential recess 46 in the first wall 41 of the first sleeve 40 or tubular, so that when the second sleeve 42 or tubular is arranged in the recess, the second sleeve 42 or tubular will not decrease the overall inner diameter of the inflow device and thereby of the production casing.

[0069] The second sleeve 42 or tubular is rotatable in relation to the first sleeve 40 or tubular at least between a first position, in which the first channel 27 and second channel (not shown) are in alignment for allowing fluid to flow from the reservoir into the production casing via the first end 43 of the second sleeve 42 or tubular, and a second position (the position shown in Fig. 9), in which

the first channel 27 and second channel (not shown) are out of alignment so that fluid is prevented from flowing into the production casing.

[0070] The inflow device 8 also comprises a first packer 47 which is arranged between the first sleeve 40 or tubular and the first end 43 of the second sleeve 42 or tubular. The packer 47 extends around the inner circumferential recess 46 and has an inner diameter which is substantially the same as that of the second sleeve or tubular. The packer 47 has the same number of through-going packer channels 48 as there are first axial channels, i.e. in this embodiment twelve, the packer channels 48 being aligned with the first axial channels 27. The packer is fixedly connected with the first sleeve or tubular so that the packer channels 48 are fluidly connected with first axial channels. The packer is ring-shaped and the through-going packer channels 48 extend through the packer along the axial extension of the first sleeve or tubular.

[0071] The packer 47 is preferably made of ceramics, whereby it is possible to make the contact surfaces of the packer 47 smooth, which enhances the sealing properties of the packer 47, since the smooth contact surface may be pressed closer to the opposite surface which is the first end 43 of the second sleeve 42 or tubular. However, in other embodiments, the packer may be made of metal, composites, polymers, or the like.

[0072] Furthermore, a second packer 49 is arranged between the first sleeve 40 or tubular and the second end 44 of the second sleeve 42 or tubular. However, in another embodiment, the second packer is omitted, whereby the second end 44 of the second sleeve 42 or tubular faces the first wall of the first sleeve 40 or tubular.

[0073] A first spring element 50 may be arranged between the first packer 47 and the first sleeve 40 or tubular.

[0074] Furthermore, the second sleeve 42 or tubular may comprise at least one recess 51 accessible from within, the recess 51 being adapted to receive a key tool (not shown) for rotating the second sleeve 42 or tubular in relation to the first sleeve 40 or tubular.

[0075] The adjustment of the inflow devices 8, 9 may be performed manually by for instance inserting a downhole tool having a key tool down in the production casing and moving the downhole tool to the inflow device which need to be adjusted. The inflow devices 8, 9 may also be operated by a magnetic source.

[0076] In other embodiments, the inflow devices may be remotely adjustable, for instance by wireline or wireless control.

[0077] The inflow device 8 is adapted to be inserted and form part of the production casing 3, thus forming a cased completion (not shown). Accordingly, the ends of the inflow device 8 are adapted to be connected with another casing element by conventional connection means, for instance by means of a threaded connection.

[0078] In the above described embodiments, the outer openings are shown as openings per se. However, the outer openings may comprise flow restrictors, throttles

or valves, such as for instance inflow control valves (not shown).

[0079] Even though the above-mentioned embodiments have been described primarily in relation to rotatable movement of the inner sleeve in relation to the outer sleeve, the inner sleeve may be slidably movable in relation to the outer sleeve.

[0080] By fluid or well fluid is meant any kind of fluid that may be present in oil or gas wells downhole, such as natural gas, oil, oil mud, crude oil, water, etc. By gas is meant any kind of gas composition present in a well, completion, or open hole, and by oil is meant any kind of oil composition, such as crude oil, an oil-containing fluid, etc. Gas, oil, and water fluids may thus all comprise other elements or substances than gas, oil, and/or water, respectively.

[0081] By a casing is meant any kind of pipe, tubing, tubular, liner, string etc. used downhole in relation to oil or natural gas production.

[0082] In the event that the tools are not submergible all the way into the casing, a downhole tractor can be used to push the tools all the way into position in the well. A downhole tractor is any kind of driving tool capable of pushing or pulling tools in a well downhole, such as a Well Tractor®.

[0083] Although the invention has been described in the above in connection with preferred embodiments of the invention, it will be evident for a person skilled in the art that several modifications are conceivable without departing from the invention as defined by the following claims.

Claims

1. A production system (1) for producing hydrocarbons from a well (2), comprising:
 - a production casing (3),
 - a first reservoir zone (6) comprising at least a first fluid (10), extending along and outside a part of the production casing (3),
 - a second reservoir zone (7) comprising at least a second fluid (11), extending along and outside another part of the production casing (3),
 - a first inflow device (8) arranged in the first reservoir zone (6) having a first inflow area and being adapted to let the first fluid (10) into the production casing (3) at a first volume rate (V1),
 - a second inflow device (9) arranged in the second reservoir zone (7) having a second inflow area and being adapted to let the second fluid (11) into the production casing (3) at a second volume rate (V2),

wherein the first and second inflow areas of the inflow devices (8,9) are adjustable, whereby the first and second inflow devices (8,9) can be adjusted so that

- the first volume rate (V1) is equal to or higher than the second volume rate (V2).
2. A production system (1) according to claim 1, wherein the inflow area is constituted by a plurality of inflow openings (24, 28, 29, 30), each having an opening area.
 3. A production system (1) according to any of the preceding claims, wherein the inflow device (8, 9) comprises a first outer sleeve (22) and a second inner sleeve (23) movable in relation to each other, the first outer sleeve (22) having outer inflow openings (24, 28, 29, 30) arranged in rows with a different number of openings in each row, and the second inner sleeve (23) having inner openings (25, 31, 32, 33, 34, 35, 36, 37, 38, 39), the inner openings being arranged with a distance between them in relation to the outer openings (24, 28, 29, 30), whereby the inner openings (25, 31, 32, 33, 34, 35, 36, 37, 38, 39) of the second inner sleeve (23) can be moved and aligned in relation to the outer openings (24, 28, 29, 30) of the first sleeve (22) so that the inflow area of the inflow device (8, 9) is adjustable.
 4. A production system (1) according to claim 3, wherein the inner openings (25, 31, 32, 33, 34, 35, 36, 37, 38, 39) of the inner sleeve (23) are arranged with predetermined distances between them so that each row of outer inflow openings (24, 28, 29, 30) can optionally be opened or closed by moving the inner sleeve (23).
 5. A production system (1) according to claims 3 or 4, wherein the inner sleeve (23) is rotatably movable in relation to the outer sleeve (22).
 6. A production system (1) according to any of the preceding claims, wherein the monitoring unit (4) is adapted to measure a water content of the production outcome so that the inflow devices (8, 9) may be adjusted, whereby an optimum between production outcome and water content is obtained.
 7. A production system (1) according to any of the preceding claims, further comprises a monitoring unit (4) adapted to measure a production outcome of the well (2).
 8. A production system (1) according to claim 8, wherein the monitoring unit (4) is adapted to measure a volume rate of the production outcome and/or a pressure at the top of the well (2) so that the inflow devices (8, 9) may be adjusted in view of volume rate and/or pressure measured at the top of the well (2).
 9. A production system (1) according to any of the preceding claims, wherein the reservoir zones (6, 7) are separated by annular barriers (12).
 10. A production system (1) according to any of the preceding claims, wherein the first fluid (10) is oil and the second fluid (11) is water or gas.
 11. A well completion comprising the production system (1) according to any of the claims 1 to 10.
 12. A production method for the production of hydrocarbons from a well (2), comprising the steps of
 - determining a first reservoir zone (6) comprising at least a first fluid (10),
 - determining a second reservoir zone (7) comprising at least a second fluid (11),
 - opening a first inflow device (8) in the first zone (6) to let the at least first fluid (10) into a production casing (3) at a first volume rate (V1),
 - opening a second inflow device (9) in the second zone (7) to let the at least second fluid (11) into the production casing (3) at a second volume rate (V2),
 - monitoring a production outcome of the well (2), and
 - adjusting the first and second inflow devices (8, 9) in view of the production outcome so that the first volume rate (V1) is equal to or higher than the second volume rate (V2).
 13. A method according to claim 12, wherein the monitoring step comprises one or more of the steps of:
 - measuring a pressure at the top of the well,
 - measuring a volume rate of the production outcome at the top of the well, or
 - measuring a water content of the production outcome at the top of the well.
 14. A method according to claims 12 or 13, wherein the adjusting step comprises adjustment of at least one of the inflow devices (8, 9) on the basis of the measured pressure, volume rate and/or water content at the top of the well.
 15. A method according to any of the claims 12-14, wherein the step of adjusting is performed manually, for instance by a key tool connected with a downhole tractor.

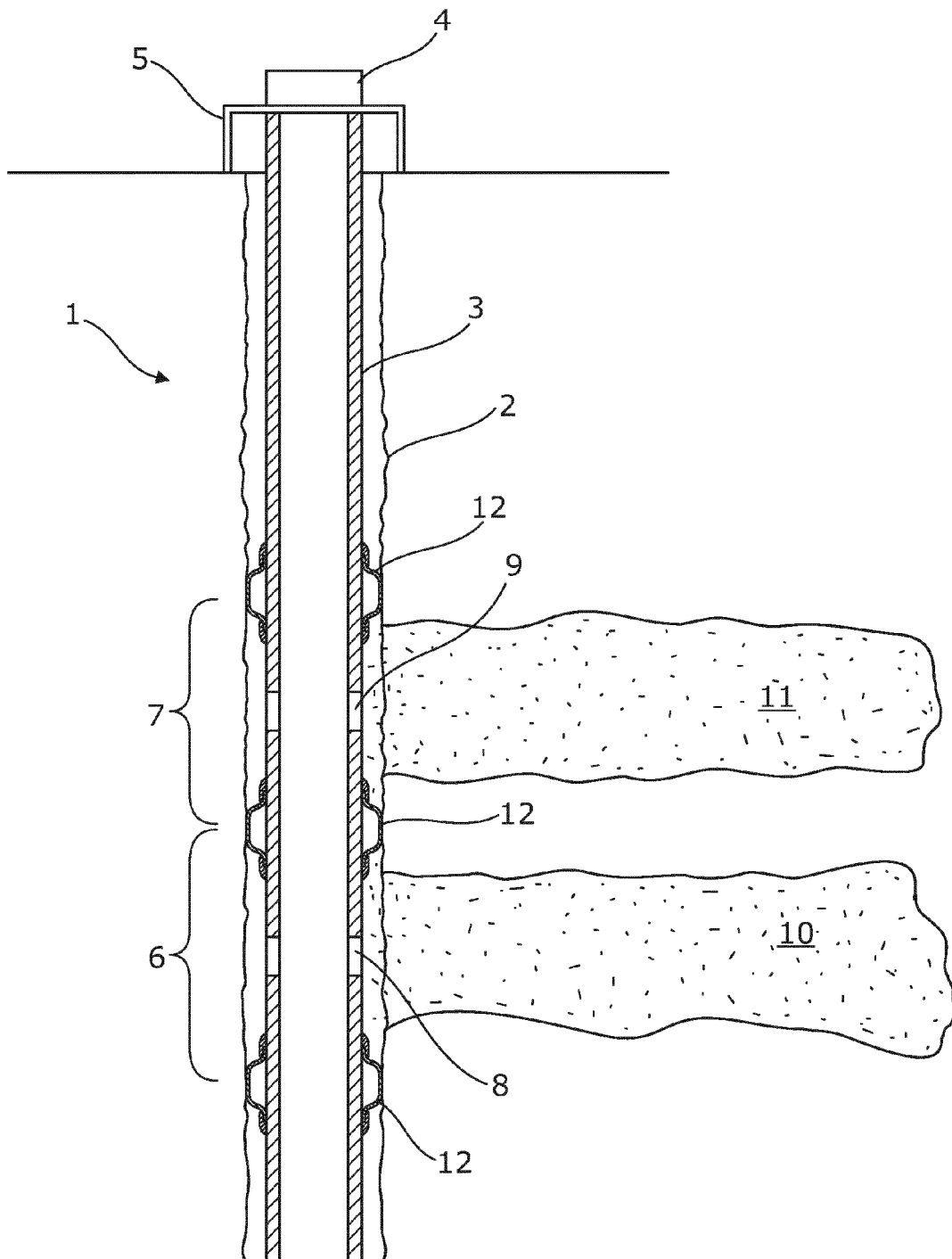

Fig. 1

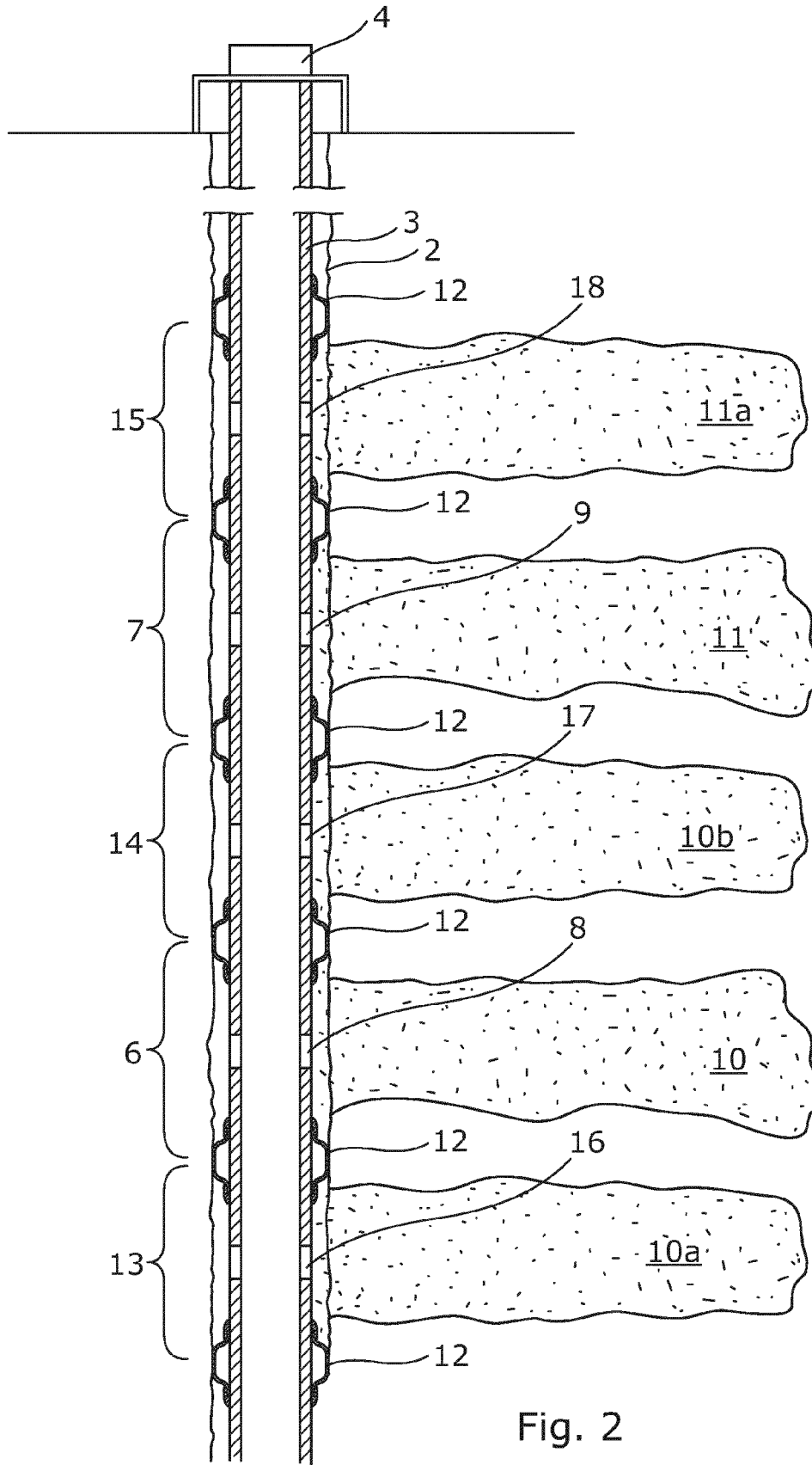

Fig. 2

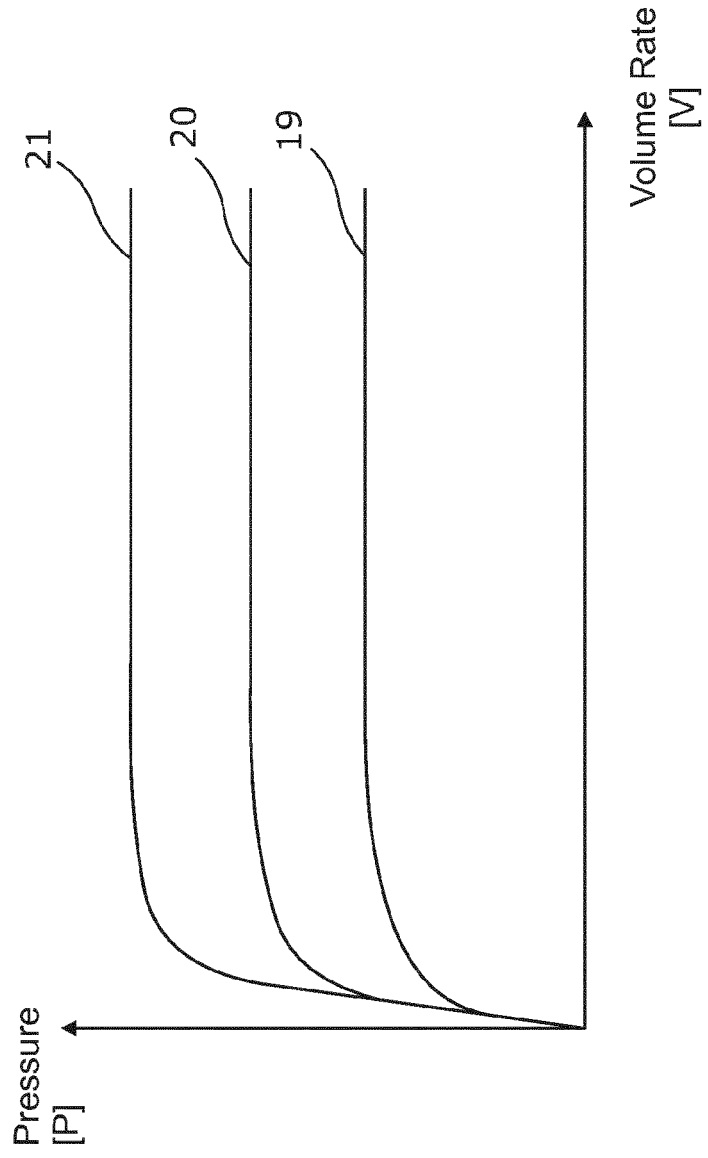
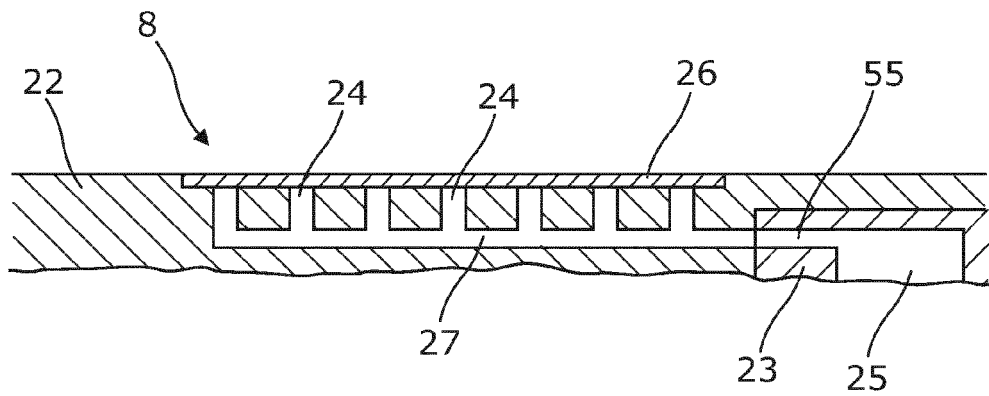
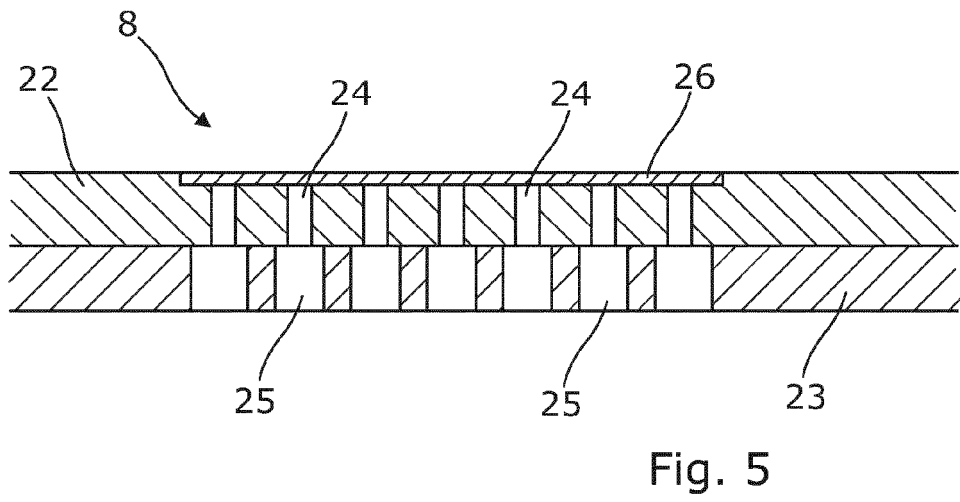
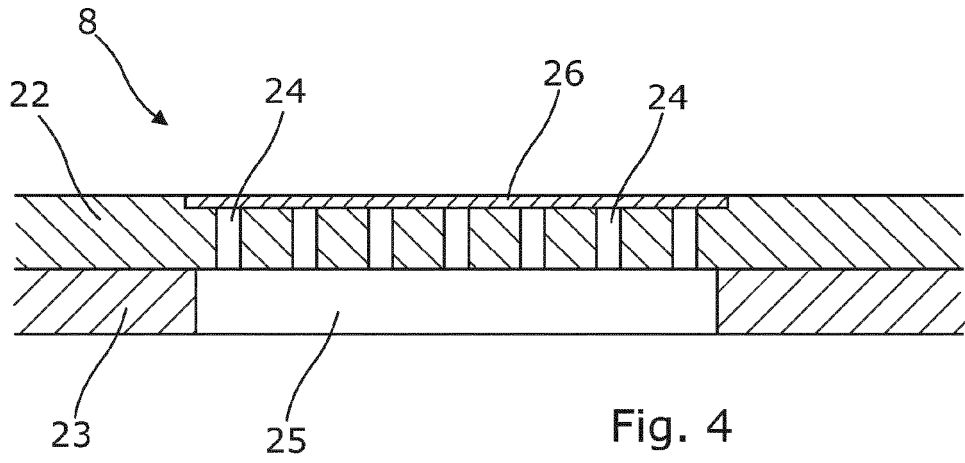

Fig. 3



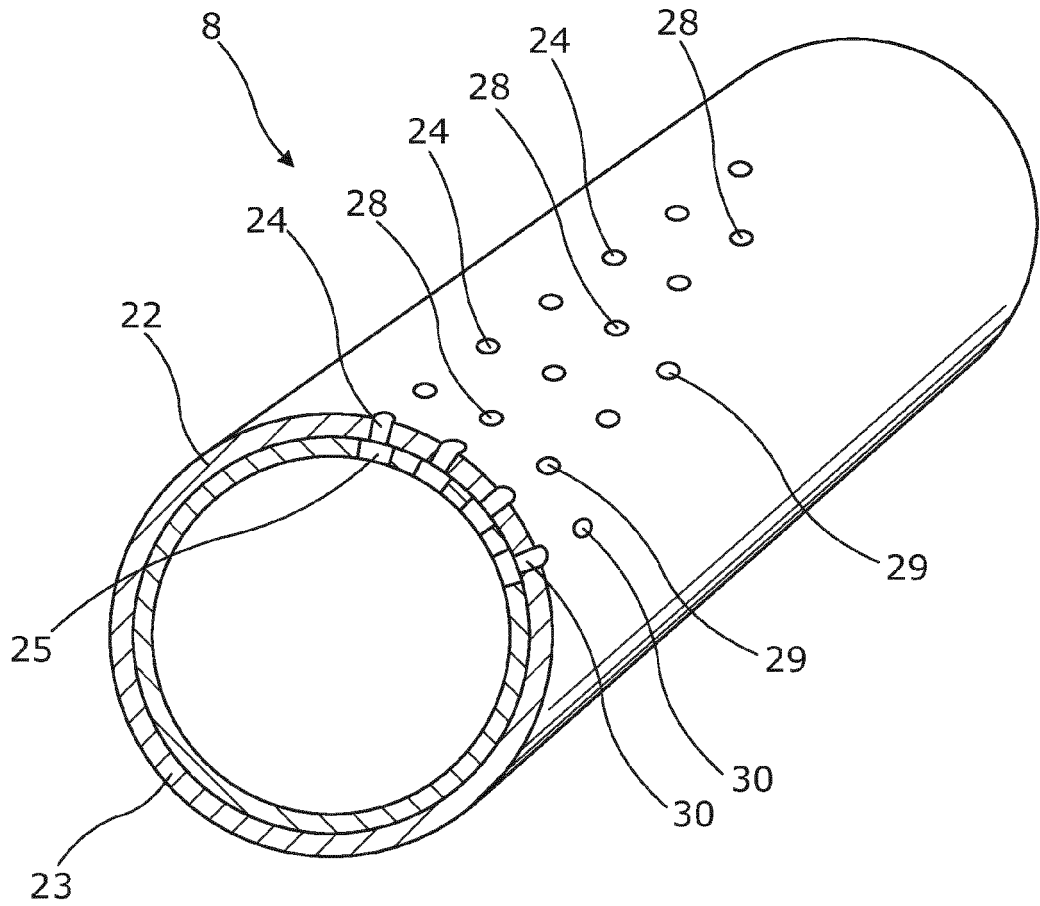

Fig. 7

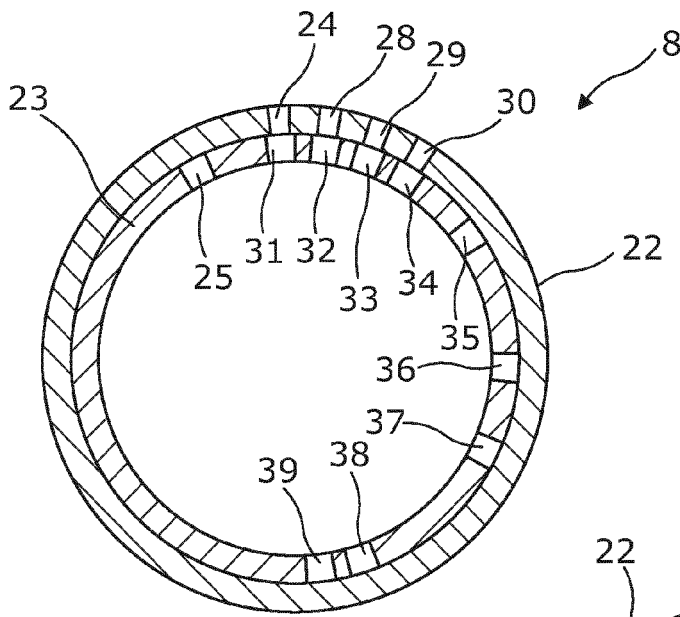

Fig. 8a

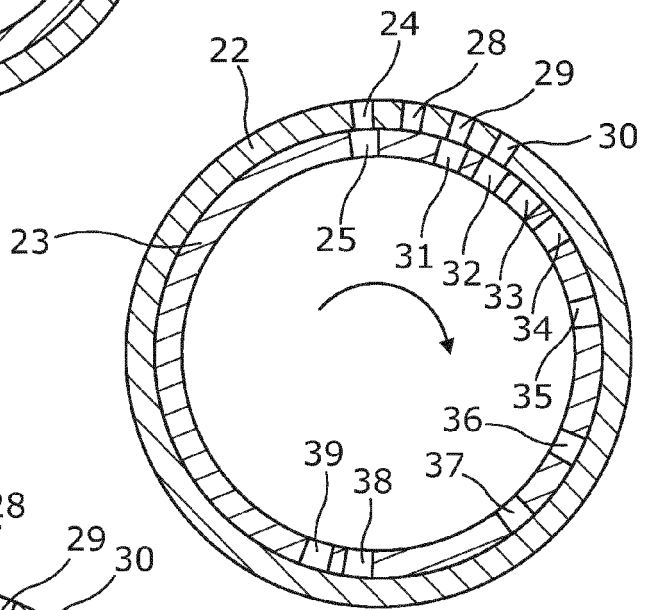

Fig. 8b

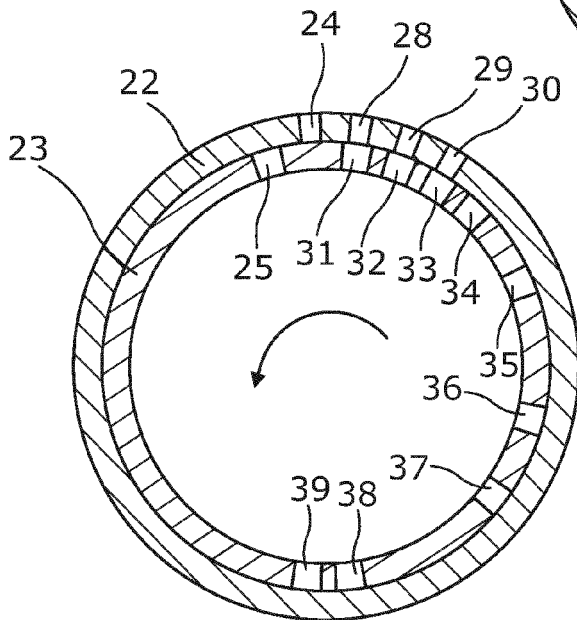

Fig. 8c

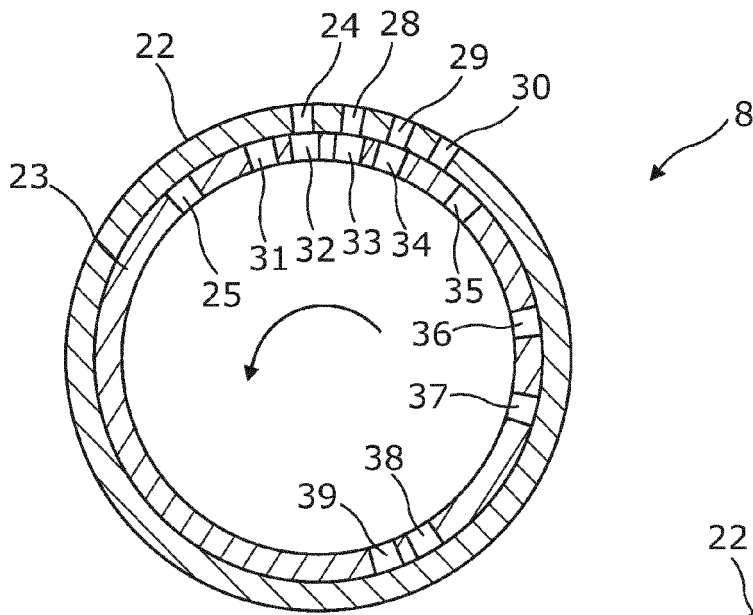

Fig. 8d

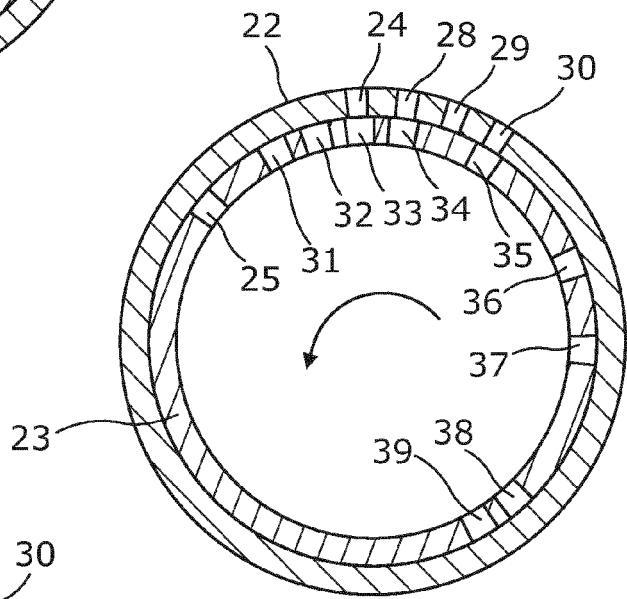

Fig. 8e

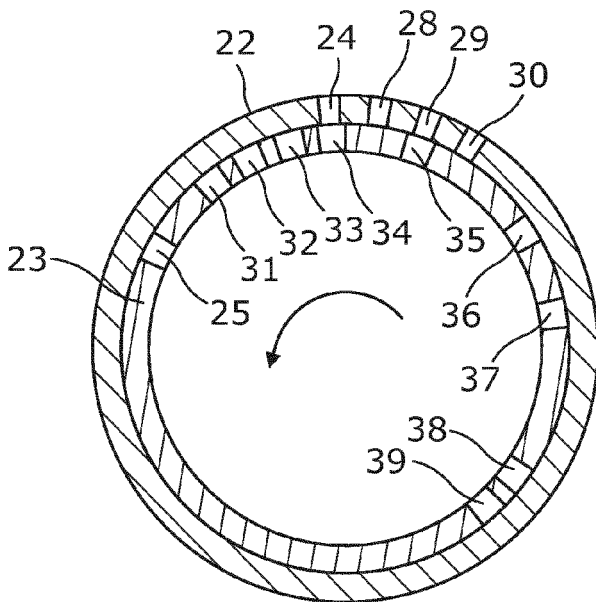

Fig. 8f

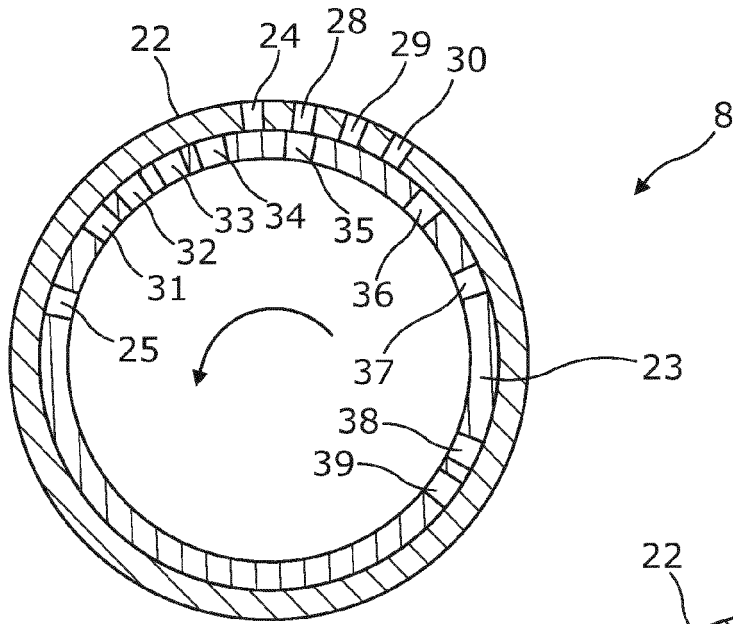

Fig. 8g

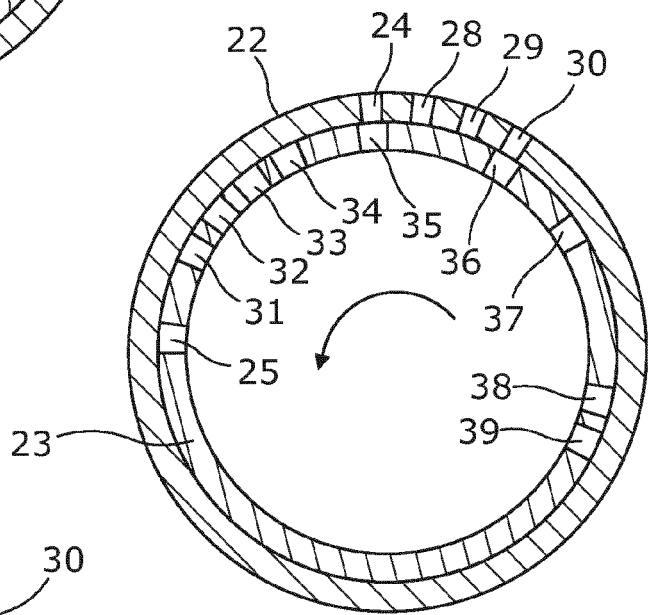

Fig. 8h

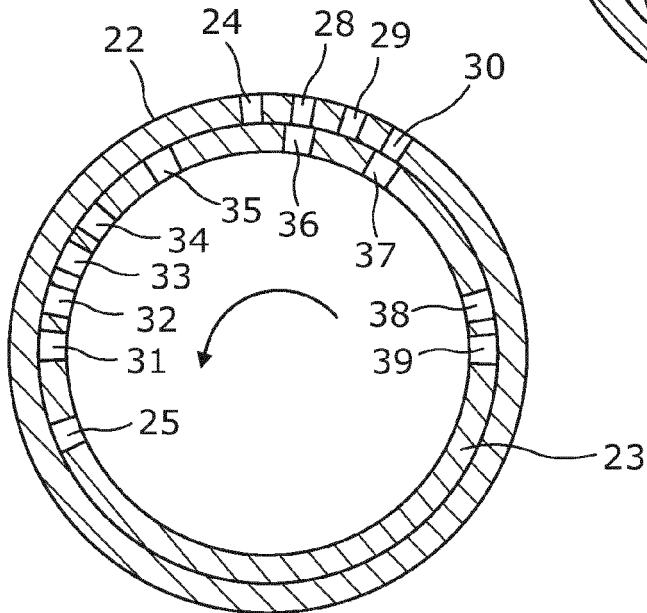

Fig. 8i

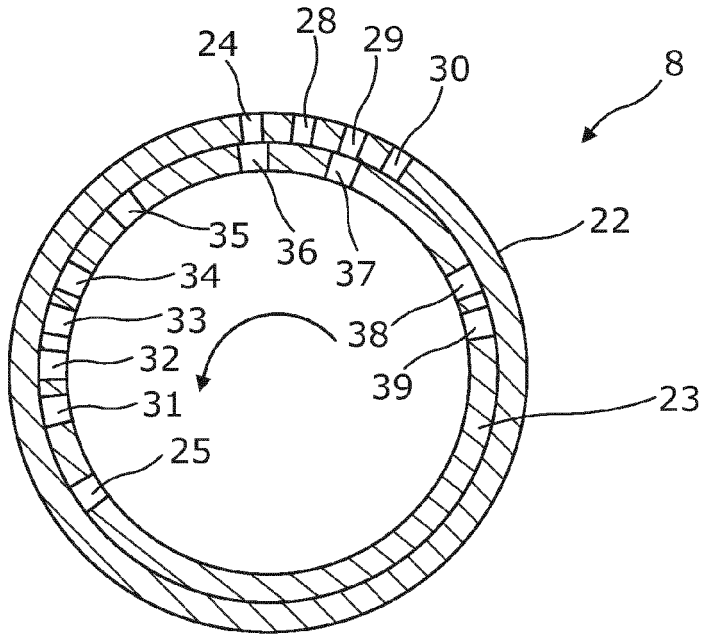

Fig. 8j

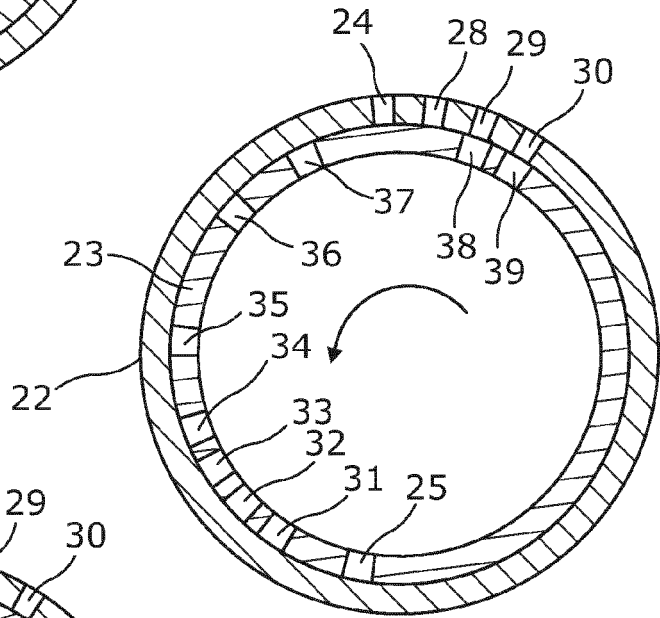

Fig. 8k

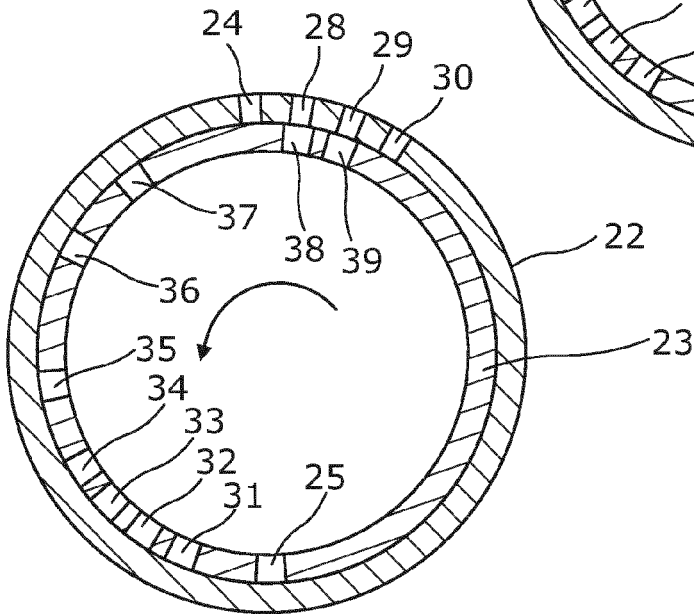

Fig. 8l

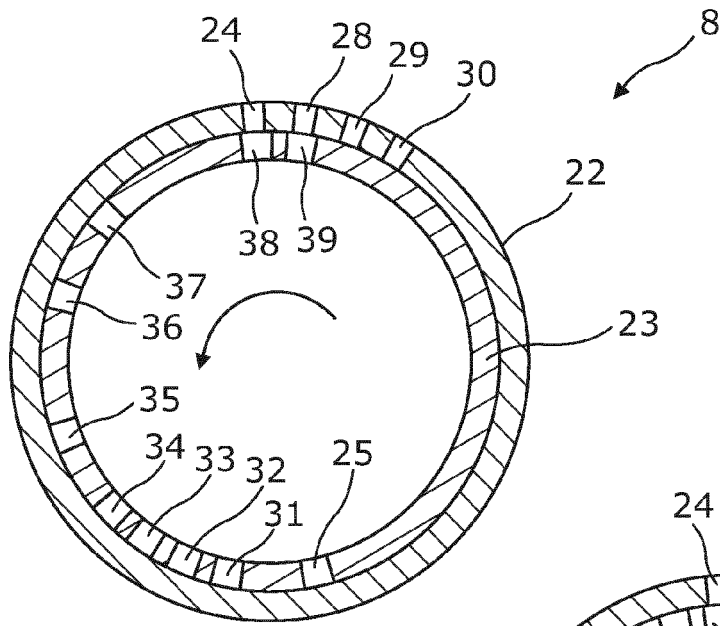

Fig. 8m

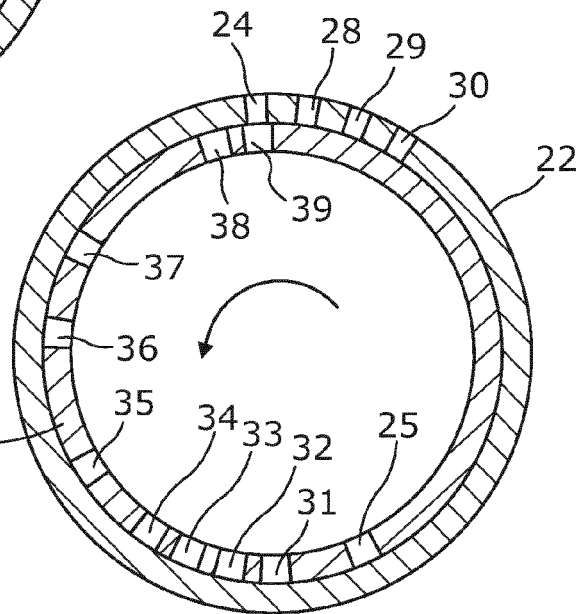

Fig. 8n

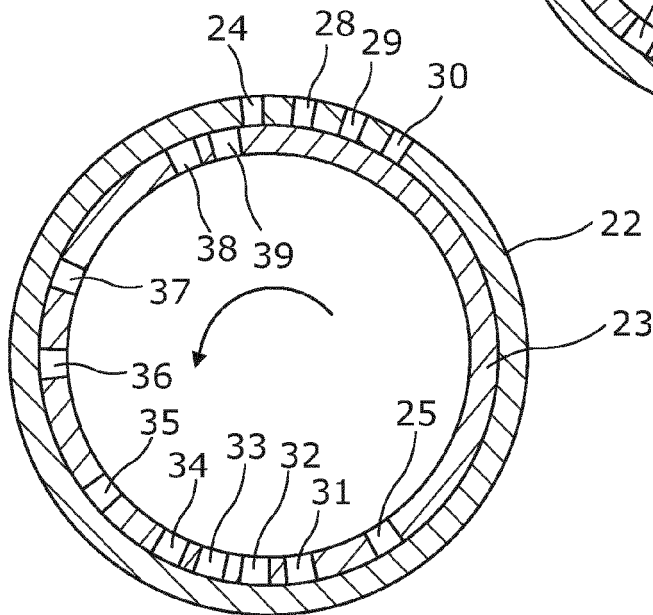

Fig. 8o

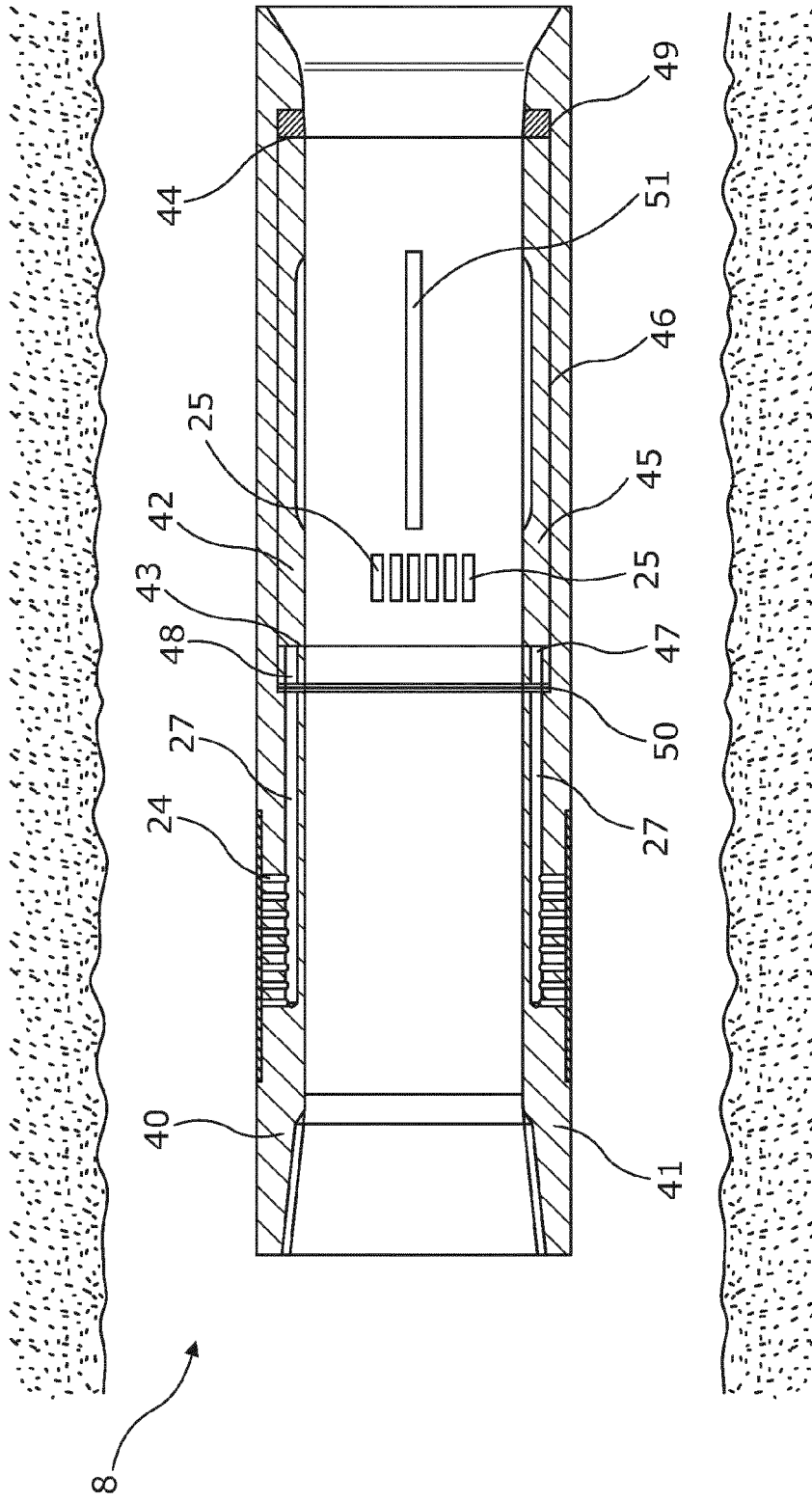

Fig. 9



EUROPEAN SEARCH REPORT

Application Number
EP 11 19 5580

DOCUMENTS CONSIDERED TO BE RELEVANT			
Category	Citation of document with indication, where appropriate, of relevant passages	Relevant to claim	CLASSIFICATION OF THE APPLICATION (IPC)
X	US 2004/149435 A1 (HENDERSON WILLIAM D [US]) 5 August 2004 (2004-08-05) * paragraphs [0008], [0009], [0010], [0013], [0035], [0045], [0047], [0049]; figures 2, 3, 4, 8, 9 * -----	1,2, 6-12,14, 15	INV. E21B34/14 E21B43/12 E21B43/14
X	US 2011/146975 A1 (O'MALLEY EDWARD J [US] ET AL) 23 June 2011 (2011-06-23) * paragraphs [0007], [0008], [0022], [0023], [0026]; figures 1, 2, 3 * -----	1,2,6-14	
X	WO 92/08875 A2 (FRAMO DEV LTD [GB]) 29 May 1992 (1992-05-29) * figures 1, 2, 4 * -----	1,2	
A	US 3 993 130 A (PAPP JOHN C) 23 November 1976 (1976-11-23) * figures 1-4 * -----	1-15	
A	US 4 691 778 A (PYNE R DAVID G [US]) 8 September 1987 (1987-09-08) * figures 1-4 * -----	1-15	TECHNICAL FIELDS SEARCHED (IPC) E21B
A	WO 2008/005495 A1 (BJ SERVICES CO [US]; ROSS RICHARD J [US]) 10 January 2008 (2008-01-10) * the whole document * -----	1-15	
The present search report has been drawn up for all claims			
Place of search Munich		Date of completion of the search 18 June 2012	Examiner Georgescu, Mihnea
CATEGORY OF CITED DOCUMENTS X : particularly relevant if taken alone Y : particularly relevant if combined with another document of the same category A : technological background O : non-written disclosure P : intermediate document		T : theory or principle underlying the invention E : earlier patent document, but published on, or after the filing date D : document cited in the application L : document cited for other reasons & : member of the same patent family, corresponding document	

1
EPO FORM 1503 03.02 (P04C01)

ANNEX TO THE EUROPEAN SEARCH REPORT
ON EUROPEAN PATENT APPLICATION NO.

EP 11 19 5580

This annex lists the patent family members relating to the patent documents cited in the above-mentioned European search report.
The members are as contained in the European Patent Office EDP file on
The European Patent Office is in no way liable for these particulars which are merely given for the purpose of information.

18-06-2012

Patent document cited in search report	Publication date	Patent family member(s)	Publication date
US 2004149435 A1	05-08-2004	US 2004149435 A1 WO 2004072432 A2	05-08-2004 26-08-2004
US 2011146975 A1	23-06-2011	US 2011146975 A1 WO 2011087673 A2	23-06-2011 21-07-2011
WO 9208875 A2	29-05-1992	AT 169371 T CA 2101446 A1 DE 558534 T1 DE 69129943 D1 DE 69129943 T2 DK 0558534 T3 EP 0558534 A1 ES 2048696 T1 GR 93300136 T1 NO 931736 A US 5447201 A WO 9208875 A2	15-08-1998 21-05-1992 03-03-1994 10-09-1998 29-04-1999 10-05-1999 08-09-1993 01-04-1994 31-01-1994 13-05-1993 05-09-1995 29-05-1992
US 3993130 A	23-11-1976	NONE	
US 4691778 A	08-09-1987	NONE	
WO 2008005495 A1	10-01-2008	BR PI0713396 A2 CN 101563522 A GB 2452884 A US 2008001111 A1 US 2009065217 A1 WO 2008005495 A1	17-04-2012 21-10-2009 18-03-2009 03-01-2008 12-03-2009 10-01-2008