

(Model.)

W. B. MACK.
INJECTOR.

No. 412,032.

Patented Oct. 1, 1889.

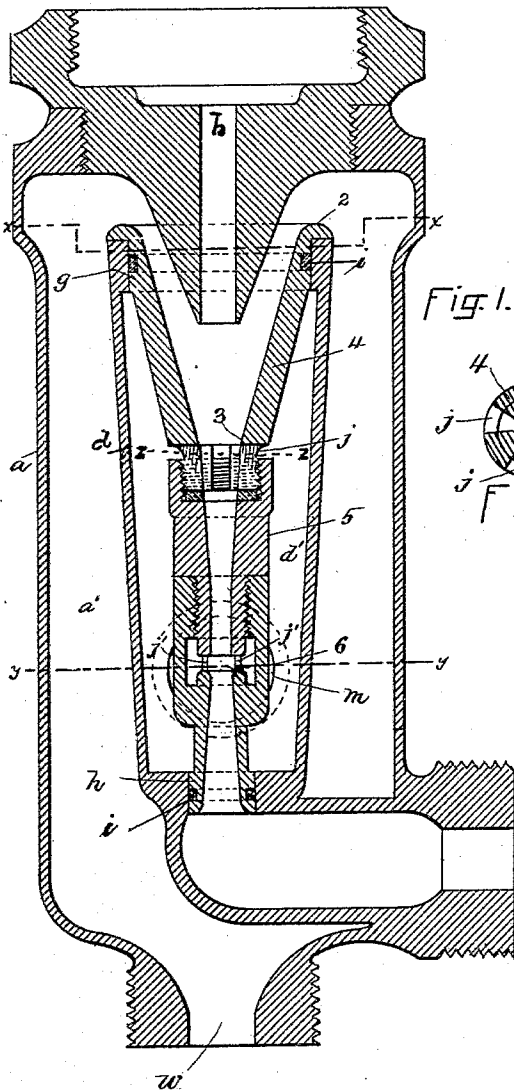

Fig. 1.

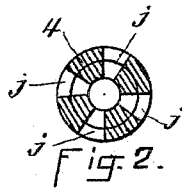

Fig. 2.

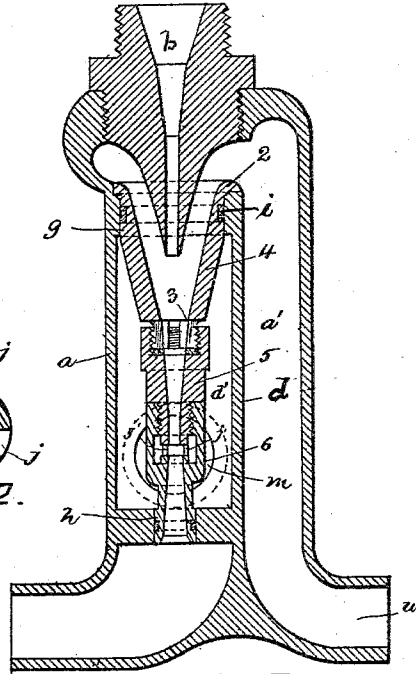

Fig. 3.

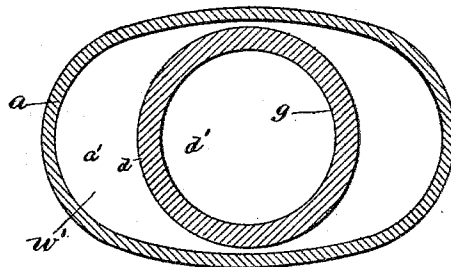

Fig. 4.

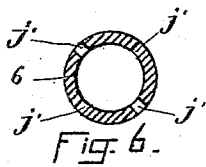

Fig. 6.

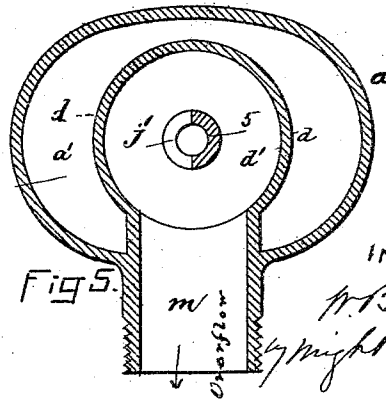

Fig. 5.

WITNESSES.
A. D. Hammon.
H. B. Ramsay.

INVENTOR.

W. B. Mack
by Wright & Brewster
Atty.

UNITED STATES PATENT OFFICE.

WILLIAM B. MACK, OF BOSTON, MASSACHUSETTS.

INJECTOR.

SPECIFICATION forming part of Letters Patent No. 412,032, dated October 1, 1889.

Application filed September 30, 1887. Renewed March 8, 1889. Serial No. 302,587. (Model.)

To all whom it may concern:

Be it known that I, WILLIAM B. MACK, of Boston, in the county of Suffolk and State of Massachusetts, have invented certain new and useful Improvements in Injectors, of which the following is a specification.

This invention has for its object to provide certain improvements in injectors, whereby the starting of the flow of water and the escape of air and surplus steam and water are facilitated; and to this end it consists in the improvements which I will now proceed to describe and claim.

Of the accompanying drawings, forming a part of this specification, Figure 1 represents a longitudinal section of an injector provided with my improvement. Fig. 2 represents a section on line $z z$, Fig. 1. Fig. 3 represents a longitudinal section of a modification. Figs. 4 and 5 represent sections on lines $x x$ and $y y$, Fig. 1; and Fig. 6 is a cross-sectional view of the delivery-tube, showing the overflow-orifices thereof.

The same letters of reference indicate the same parts in all the figures.

In the drawings, a represents the external casing of an injector; and a' , the main chamber thereof, and to this casing is suitably affixed the steam-cone b .

d represents a casing forming an inner chamber d' within the chamber a' , and attached to the casing a either by being cast therewith or in any other suitable manner. The casing d is shown in Figs. 1, 4, and 5 as formed entirely within the chamber a' , while in Fig. 3 it is shown as located near one side of the casing a , so that one side of said casing also forms one side of the chamber d' .

w represents the water-inlet, which communicates through the chamber a' between the inner and outer casings with the combining-cone.

The combining-cone 4 5 and the delivery-cone 6 are fitted in the casing d so as to prevent entrance of water into the chamber d' from the chamber a' , the larger end of the combining-cone being closely fitted to a seat g at one end of the casing d , while the smaller end of the delivery-cone is fitted closely in a seat or socket h formed in a partition which constitutes one end of the chamber d' . The portions of the said cones that enter the seats

$g h$ are preferably grooved to receive lead packings $i i$, whereby water-tight joints are formed.

The delivery-cone 6 has overflow or vent orifices j' near its delivering end communicating with the chamber d' . Said orifices permit the water to flow readily outward under the influence of back-pressure.

m represents an overflow-passage extending from the casing d and chamber d' through the outer chamber a' and casing a to conduct away from the injector the waste water and steam escaping through the orifices j' .

When steam is first admitted to the combining-cone of an injector, a considerable volume of air is forced by it into the combining-cone before the water commences to flow into said cone. The air and steam so fill the cone at the commencement of the operation that the entrance of the water is considerably retarded. To obviate this I provide relief-vents j in the combining-cone, at or near the inner end of the abruptly-tapered portion 2 3 of said cone. Said vents, by permitting the escape of air from the combining-cone into the inner chamber d' and out through the overflow, permit the quick introduction of water at the commencement of the operation.

The relief-orifices j' , formed in the delivery-cone, in connection with the vents j in the combining-cone and the chamber d' , surrounding the two cones, into which said orifices and vents open, and being separated from the water entering the injector, enable the injector to resume its operation more promptly after stoppage than in injectors heretofore made.

The combining-cone is made in two sections 4 and 5, and the delivery-cone 6 is made in still another piece or section, which is internally threaded and screwed onto a nipple formed on the section 5. The section 4 is reduced at one end and externally threaded to screw into a socket in the section 5.

The air-relief orifices j are formed in the reduced and threaded end of the section 4, and are partly covered by the socket into which said threaded end is screwed, so that by adjusting the section 5 upon the section 4 the size of the relief-orifices j can be varied. This adjustability of the orifices j enables the size of the orifices to be varied to suit different circumstances. The operative size of said

orifices is necessarily greater under some circumstances than under others, so that orifices which may be of the proper size in one injector may be too small or too large for another. The adjustable construction enables the same combining-cone to be used under all circumstances.

The improved adjustable combining-cone can be applied to injector-casings which are not provided with the casing *d* and chamber *d'*. It is obvious, however, that the chamber *d'* is an advantageous adjunct of the air-relief vents *j'*, since it permits the free escape of air and steam through said vents to the overflow-passage *m*.

I claim—

1. In an injector, the combination, with the outer and inner casings, of the combining-cone fitted at its widened end on one end of said inner casing and composed of sections 4 5, the former being provided at its lower end with a reduced threaded portion and with a series of air-vents or relief-orifices, and the section 5 having its upper end fitted on said threaded portion and designed to extend over said orifices, substantially as shown and described.

2. An injector having an outer casing *a*, forming a chamber *a'*; and provided with a steam-cone at its upper end and a water-inlet at its lower end, an inner chamber within, but having no connection with, said outer chamber, an overflow-passage extending from said inner chamber through the outer chamber and casing, and combining and delivery cones fitted in said inner chamber, as described, the combining-cone being provided with air-relief orifices *j*, and said delivery-cone having water-overflow orifices, both said orifices communicating with said inner chamber

and through the latter with the overflow-passage, as set forth.

3. The herein-described improved injector, comprising the outer casing forming a chamber *a'*, the casing *d* located within said chamber and forming an inner chamber having no connection with said former chamber, the combining-cone made in sections 4 5, the section 4 having a lower threaded end and air-relief orifices, and the section 5 adjustably secured on said threaded end and designed to extend over said orifices, the delivery-cone secured to the lower end of said combining-cone and having water-overflow orifices, and the overflow-passage extending from said inner chamber and casing through said outer chamber and casing, substantially as shown and described, said air and water orifices opening into said inner chamber, as set forth.

4. In an injector, the combination of the two-part casing comprising the outer casing *a* and the inner casing *d*, forming inner and outer chambers *a'* *d'*, said inner chamber having no connection with said outer chamber and provided with an overflow-passage *m*, the steam-cone screwed into the end of the outer casing, the combining and delivery cones passing through the inner chamber and having vents communicating directly with the latter and with said overflow, all arranged and operating substantially as described.

In testimony whereof I have signed my name to this specification, in the presence of two subscribing witnesses, this 17th day of September, A. D. 1887.

WILLIAM B. MACK.

Witnesses:

J. MILLER STEWART,
C. F. BROWN.