

N. POWER.
 PERFORATING MACHINE.
 APPLICATION FILED OCT. 4, 1910.

1,031,468.

Patented July 2, 1912.

3 SHEETS—SHEET 1.

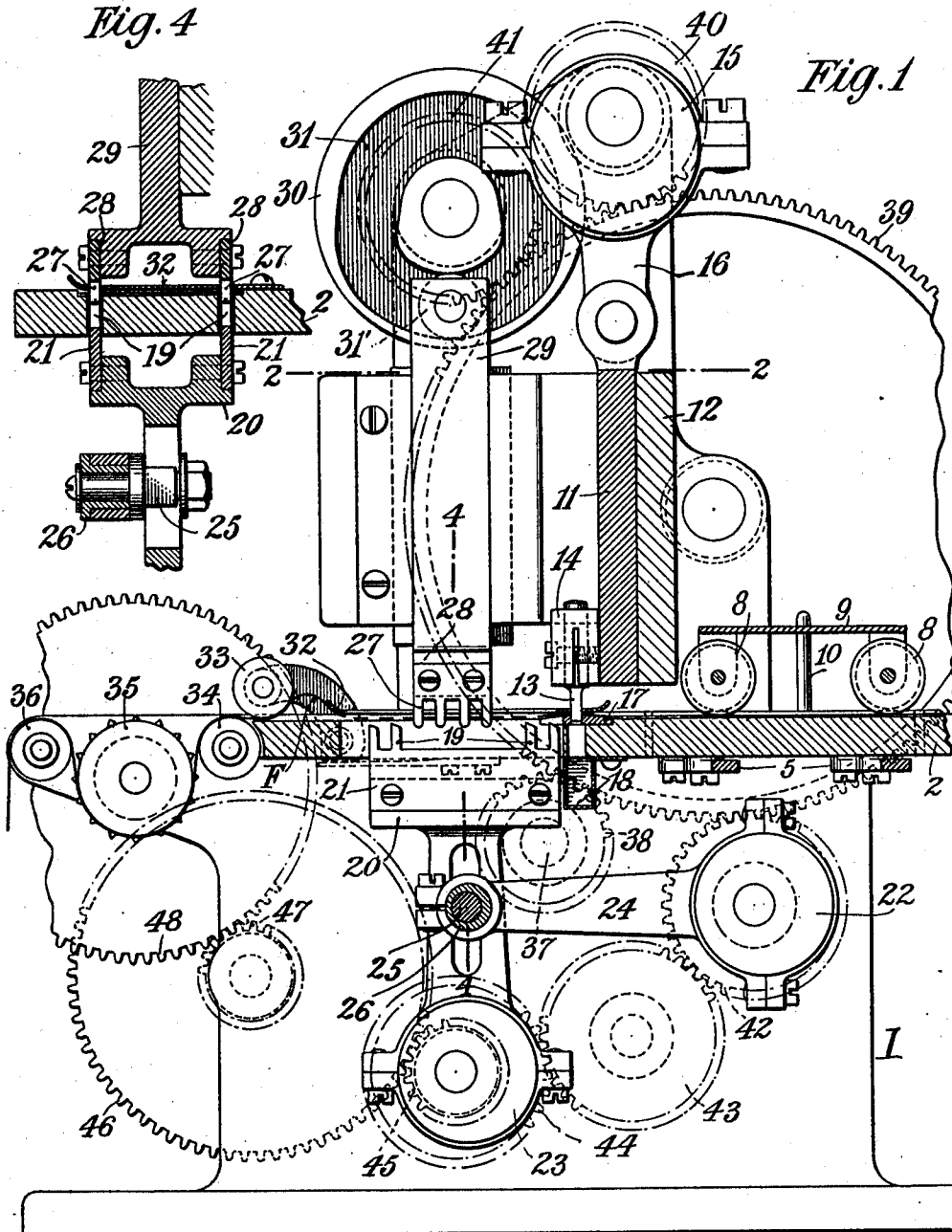

Witnesses:
Raphael Ketter
Frank Zuber

Nicholas Power Inventor
 By *his Attorney* *Roscoe Norton*

N. POWER.
 PERFORATING MACHINE.
 APPLICATION FILED OCT. 4, 1910.

1,031,468.

Patented July 2, 1912.

3 SHEETS-SHEET 2.

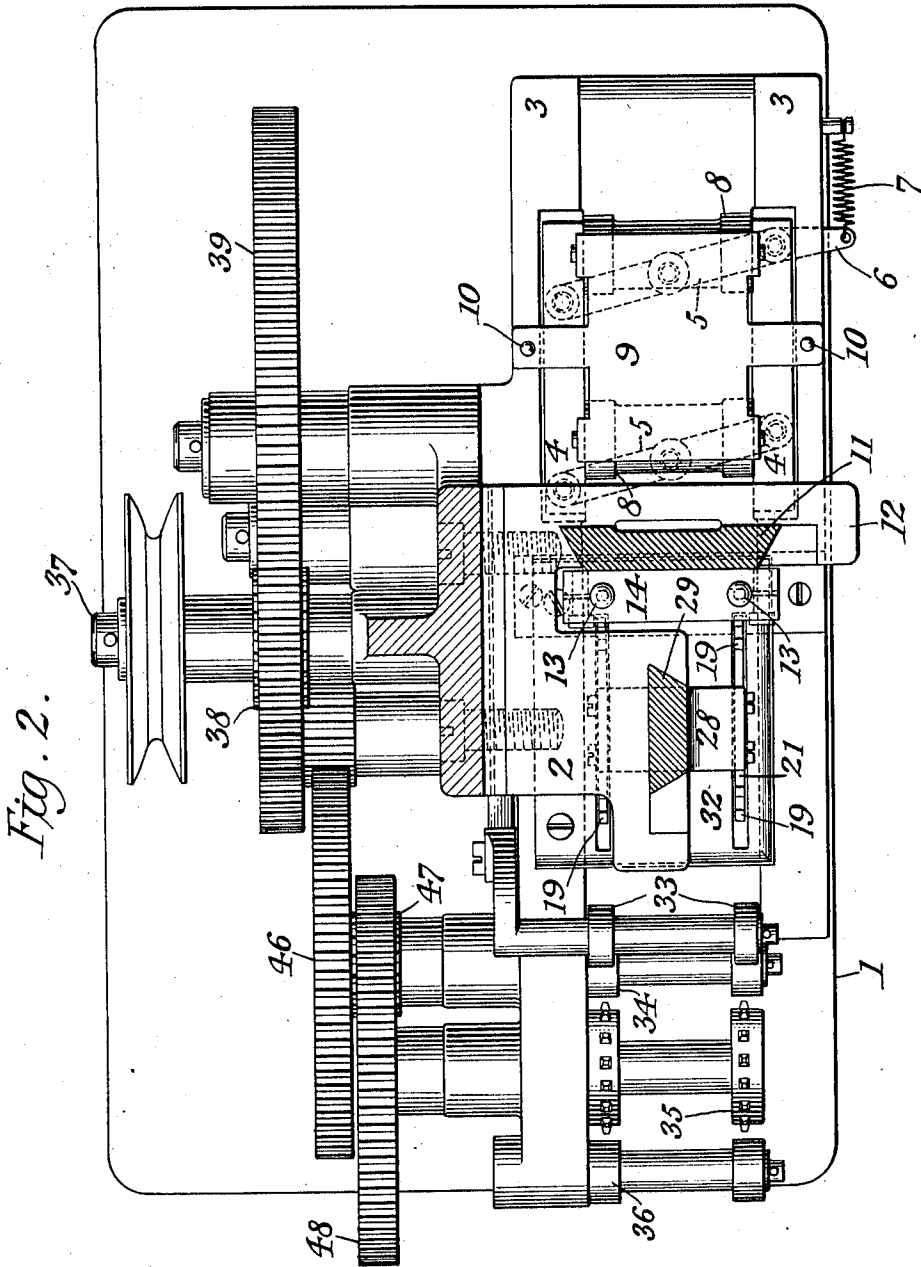

Witnesses:
Raphaël Ketter
Frank Zuber

Nicholas Power Inventor
 By *his Attorney, Rayner Norton*

N. POWER.
 PERFORATING MACHINE.
 APPLICATION FILED OCT. 4, 1910.

1,031,468.

Patented July 2, 1912.

3 SHEETS-SHEET 3.

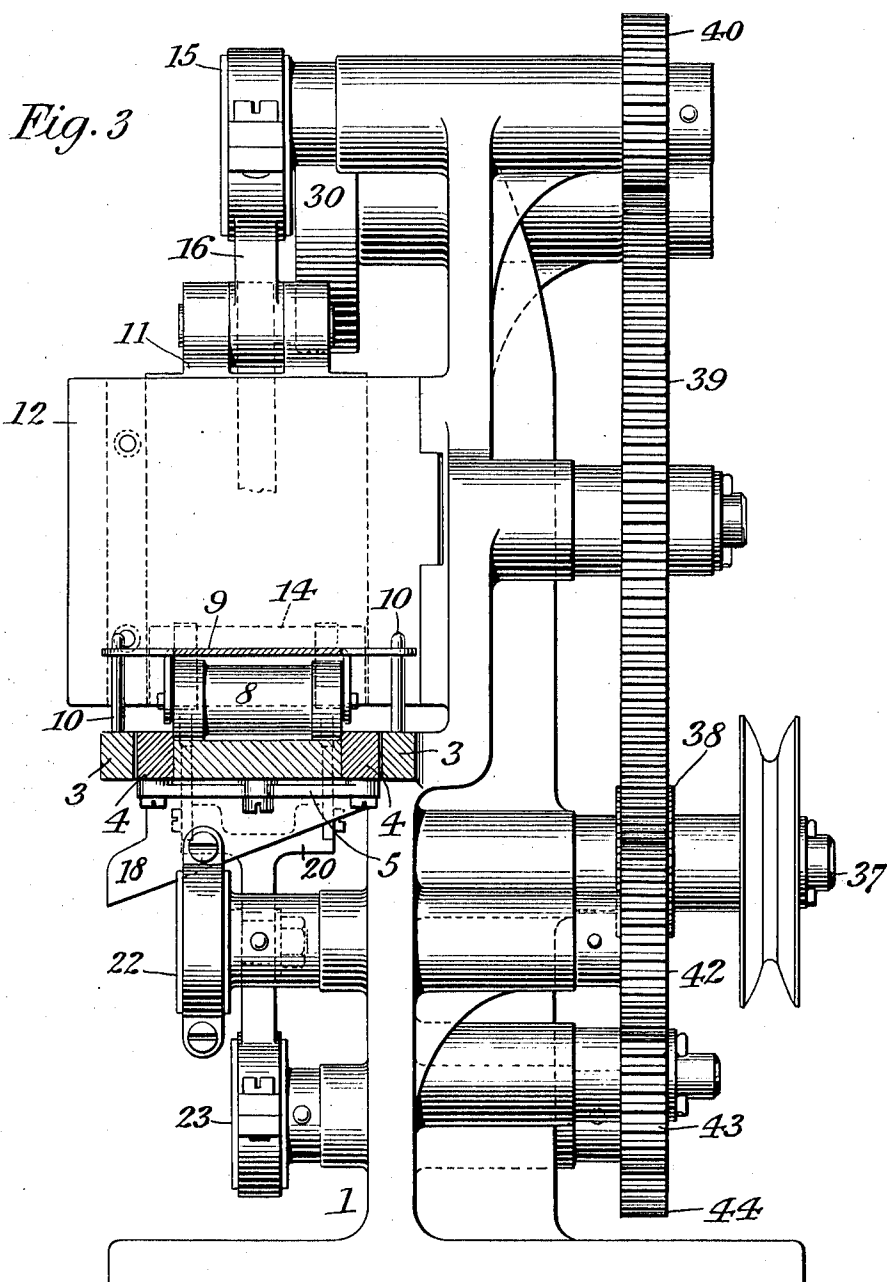

Witnesses:
Raphael Hetter
Frank Zuber

Nicholas Power Inventor
 By *his Attorney* *Reuben Morton*

UNITED STATES PATENT OFFICE.

NICHOLAS POWER, OF BROOKLYN, NEW YORK.

PERFORATING-MACHINE.

1,031,468.

Specification of Letters Patent.

Patented July 2, 1912.

Application filed October 4, 1910. Serial No. 585,203.

To all whom it may concern:

Be it known that I, NICHOLAS POWER, a citizen of the United States, residing at Brooklyn, in the county of Kings and State of New York, with post-office address at No. 388 Jefferson avenue, have invented certain new and useful Improvements in Perforating-Machines, of which the following is a specification.

This invention relates to perforating machines, and more particularly to the machine for perforating strips of celluloid or other material used in the manufacture of moving picture films.

The primary object of the invention is to produce a compact, durable and inexpensive machine of the character specified, by which strips of thin material may be perforated along the margins with great accuracy in order to insure exactly uniform spacing of the perforations.

In the accompanying drawings I have illustrated one embodiment of the invention only, but it will be understood that various modifications in the form and arrangement of the parts may be made without departing from the spirit of the invention.

In the drawings: Figure 1, is a view partly in vertical section and partly in elevation of the perforating machine, a portion of the gearing being broken away to save space. Fig. 2, is a view partly in plan and partly in horizontal section in the plane 2-2 of Fig. 1. Fig. 3, is a view in end elevation looking in the direction in which the film travels through the machine. Fig. 4, is a detail view in vertical section on the line 4-4 of Fig. 1.

In the several views corresponding parts are designated by similar characters of reference throughout.

As in other machines of this class, the machine embodying the present invention comprises a bed along which the film travels, suitable film guiding devices, a reciprocating punching mechanism and feeding device for the film. The feeding device comprises in addition to means for moving the film forward step by step, certain locking devices by means of which the film is accurately locked after each advance, so that the holes punched by each operation of the punch are exactly spaced from the holes produced by the immediately preceding operation of the punch.

As illustrated in the drawings, the ma-

chine comprises a main frame 1, which is preferably a casting of suitable material and provided at suitable height above the base with the horizontal bed 2, which is best shown in Fig. 2. This bed is provided throughout a greater portion of its length with raised side portions 3, spaced apart sufficiently to receive the film between and to allow a little clearance on either side. These films are ordinarily $1\frac{3}{8}$ inches in width, but vary slightly so that the raised sides of the bed which are fixed in position cannot be relied upon entirely to guide the film properly to the punching device. Consequently I find it desirable to provide additional guiding means which are also shown most clearly in Fig. 2. This guiding device comprises a pair of parallel bars or strips 4, arranged in recesses provided for them at the sides of the film bed 2. To keep the guide strips 4 always parallel I support them on pivoted links 5, which turn on pivots arranged in the median line of the film track. To insure the proper engagement of the guide strips 4 with the edges of the film, one of the links 5 is provided with an extension 6, on one end of which is connected a light tension spring 7, the pull of which is just sufficient to insure engagement of the guide strips with the film without buckling the film. To keep the film entirely flat on the bed as it travels toward the punching device I provide a pair of metal rollers, 8, which are pivoted in a small frame 9, and rest directly upon the film as it lies in the film track. These rollers are heavy enough to hold the film flat and are preferably reduced in diameter between the ends, so as to confine the rubbing of the rollers on the film to the edge portions. To take care of inequalities in the thickness of the film, the frame 9, in which the rollers 8 are mounted, is held in position by vertical pins, 10, which permit the frame to move up and down on the pins.

The punching mechanism is arranged just beyond the rollers, 8, and comprises a slide, 11, working in a guide, 12, which is preferably cast integral with the machine. The punches, 13, are attached to the slide, 11, by a clamp, 14, of any suitable construction, and the necessary reciprocating motion is imparted to the slide by means of an eccentric 15, and link, 16, operated through gearing which will presently be described. The punches, 13, cooperate with a plate 17,

provided with suitable openings, and set into the film bed, 2, of the machine. Just below the plate 17, a chute 18 is arranged to receive the punchings which drop from the film.

5 The film feeding mechanism is arranged immediately beyond the punching mechanism and comprises a plurality of fingers, 19, mounted on a carrier, 20. The feeding fingers, 19, are arranged to engage perforations at both sides of the film and are preferably made a trifle smaller than the punches, 13, so as to allow easy engagement of the fingers with the perforations. To permit easy replacement of the feeding fingers they are preferably formed on plates 21 which are secured to the sides of the carrier 20. Each plate 21 has a pair of feed fingers at each end with an open space between, the purpose of which will presently appear. The motion imparted to the carrier 20 is a compound motion resulting from the simultaneous action of two eccentrics 22, 23; the former imparting a horizontal movement and the latter a vertical movement. These two eccentrics are so proportioned and arranged that in the operation of the machine the first movement of the carrier from the position shown in Fig. 1, is upward to engage the film, then horizontal to feed the film, then downward to disengage the film, then horizontal to bring it back to the position shown in Fig. 1, in readiness to engage the film again. The eccentric 22 operates a link or pitman 24, which is adjustably connected with the shank of the carrier 20, which is provided with a slot to receive the pin 25 to which the pitman 24 is secured. The pitman is not directly connected with the pin 25 but is preferably mounted on an eccentric bushing 26 which is in turn secured upon the pin, as shown in Fig. 4.

45 The movement of the film produced by the feeding mechanism above described, is substantially uniform for any setting of the adjustable connection between the pitman 24 and the shank of the carrier 20, but in order to insure perfect accuracy of spacing between the perforations, I provide also a combined locking and positioning mechanism which engages the film after each operation of the feeding device. This locking and positioning mechanism comprises a plurality of fingers 27, supported on suitable reciprocating devices exactly above the carrier 20. The fingers 27 are formed in two plates 28 which are secured to a slide 29 which is operated by means of an internal cam 30, which is provided with a groove 31 to receive a roller 31' carried by the slide 29. The fingers 27 are rounded at their free end to insure engagement with the perforations in the film without possibility of tearing, and are of such cross section that they

exactly fill the perforations formed in the film. As no play is allowed the slides which carry the punches and the locking pins, an exact distance is always obtained between the punches 13 and the locking fingers 27, and any slight variations in the feeding movement of the film after the operation of the punches is corrected by the locking fingers which also serve to hold the film perfectly still during the operation of the punches. In order to strip the film from the punches 13 and the locking fingers 27, on their upward movements, I provide a fixed stripper plate 32 above the film bed and in suitable relation to the punches and locking fingers. After passing from under the stripper plate 32 the film passes under a guide roller 33 and over the guide roller 34, thence to a sprocket wheel 35 with suitable spaced teeth, and finally over the guide roller 36, from which it passes to any suitable mechanism for winding it on reels or spools. The sprocket wheel 35 is provided to prevent the winding devices (not shown) from drawing the film forward too rapidly, and the sprocket is therefore rotated constantly at a uniform speed. As the operation of the film feeding device is intermittent in character and the rotation of the sprocket 35 is constant, it is necessary to allow a small amount of slack in the film between the stripper plate 32 and the sprocket 35, and it will be noted on examination of Fig. 1, that a small loop or bow is formed in the film between the stripper plate 32 and the guide roller 33.

Motion is imparted to the various parts of the perforating machine from any suitable source of power through suitably arranged gearing. As illustrated in the drawings, power is initially supplied to a main shaft 37 from which it is transmitted to a pinion 38, meshing with a master gear 39, which in turn meshes with a pinion 40, which drives an eccentric 15, a pinion 41 which drives the cam 30, and a pinion 42 which drives the eccentric 22. Motion is imparted to the eccentric 23 through an idler pinion 43 arranged between the pinion 42 and the pinion 44, which drives the eccentric 23. On the same shaft with the pinion 44 is a smaller pinion 45 which meshes with the idler gear 46, rigidly connected with a pinion 47, which in turn drives the gear 48 fast on the spindle of the sprocket 35.

The operation of the perforating machine has been indicated in the foregoing description and may be recapitulated as follows: The end of the film to be perforated is passed under the pressure rollers and positioned between the guide strips 4, between which it is moved forward by hand until the end of it rests on the plate 17, immediately under the punches 13. The machine is then start-

ed and the punching mechanism operated once. The film is then advanced by hand until the perforations formed by the single operation of the punch are immediately above the first two fingers of the feeding device. The machine is then started again and kept in operation. After the second operation of the punches the feeding devices engage the film and advance it one space, when the punches again operate to form a third pair of perforations. The feeding devices again advance the film one space, thus bringing the perforations first formed into position to be engaged by the first pair of locking fingers. As the operation of the machine continues the film advances until the feeding fingers beyond the locking fingers come into play, which then assist in feeding the film. After a few inches of the film have been perforated, the perforated portion can be passed around the sprocket and thence to winding devices of any suitable character.

Having thus described my invention, as new, I desire to secure by Letters Patent:

1. In apparatus for perforating thin strips of material, the combination with a punch, of feeding devices adjacent to the punch and comprising fingers positively moved to engage and disengage the openings punched in the material, and locking fingers adapted to engage said openings after each operation of the feeding devices, thereby holding the material in fixed position during the next punching operation of the punch.

2. In apparatus for perforating strips of thin material the combination with punching devices of mechanism for feeding said material and exactly spacing the perforations therein, said mechanism comprising a plurality of feeding fingers together with means for bringing said fingers into engagement with and disengagement from openings formed in the material and means for advancing said fingers in the direction of travel of said material, and locking mechanism operative after the advance of the material, said locking mechanism comprising a plurality of fingers adapted to engage

and exactly fill the openings in the material and hold it stationary during the next operations of the punching devices.

3. In apparatus for perforating moving picture films, the combination with reciprocatory punching devices, of a carrier arranged adjacent to and beyond the punching devices in the direction of travel of the film, feeding fingers carried by said carrier and adapted to engage the perforations formed in the film, operating devices for said carrier adapted to impart reciprocatory movements thereto in planes at right angles to each other, and film locking devices comprising a slide arranged above said carrier and having locking fingers adapted to engage the perforations in the film to hold it stationary, and means for reciprocating said slide in such relation to the movements of the film feeding devices that the locking fingers will engage the film immediately after each advance of the film.

4. In apparatus of the character described the combination with punching devices of film feeding devices adjacent to said punching devices and adapted to engage the film after the first operation of the punching devices, said feeding devices comprising a carrier having one or more feeding fingers immediately adjacent to the punching devices and one or more feeding fingers spaced at a considerable distance from the first mentioned feeding fingers, and film locking devices above said carrier and between the sets of feeding fingers mounted thereon.

5. In apparatus of the character specified, film guiding devices comprising a pair of parallel guide strips spaced apart to receive the film between them, a pair of parallel pivoted supports for said guide strips and means for holding said guide strips in engagement with the edges of said film when placed between them.

In testimony whereof, I have signed my name hereto in the presence of witnesses.

NICHOLAS POWER.

Witnesses:

N. D. ALLING,
L. W. ATWATER.