

(19)



(11)

**EP 1 574 652 B1**

(12)

**EUROPEAN PATENT SPECIFICATION**

(45) Date of publication and mention of the grant of the patent:

**02.04.2008 Bulletin 2008/14**

(51) Int Cl.:

**E05D 15/10<sup>(2006.01)</sup> E05F 15/14<sup>(2006.01)</sup>**

(21) Application number: **02796794.2**

(86) International application number:

**PCT/ES2002/000601**

(22) Date of filing: **16.12.2002**

(87) International publication number:

**WO 2004/055307 (01.07.2004 Gazette 2004/27)**

(54) **Sliding doors with actuation mechanism thereof**

Schiebetüren mit Betätigungsmechanismus

Portes coulissantes avec mecanisme de commande

(84) Designated Contracting States:

**AT BE BG CH CY CZ DE DK EE ES FI FR GB GR  
IE IT LI LU MC NL PT SE SI SK TR**

(72) Inventor: **Romero Martinez, Manuel**  
**28007 Madrid (ES)**

(43) Date of publication of application:

**14.09.2005 Bulletin 2005/37**

(74) Representative: **Carpintero Lopez, Francisco**  
**Herrero & Asociados, S.L.**  
**Alcalá 35**  
**28014 Madrid (ES)**

(73) Proprietor: **Albatros, S.L.**  
**28014 Madrid (ES)**

(56) References cited:

**WO-A1-01/85518 BE-A- 622 387**  
**DE-A1- 4 316 253 FR-A1- 2 795 446**

**EP 1 574 652 B1**

Note: Within nine months from the publication of the mention of the grant of the European patent, any person may give notice to the European Patent Office of opposition to the European patent granted. Notice of opposition shall be filed in a written reasoned statement. It shall not be deemed to have been filed until the opposition fee has been paid. (Art. 99(1) European Patent Convention).

## Description

### OBJECT OF THE INVENTION

**[0001]** The present invention refers to sliding door with an activating mechanism thereof, wherein the activating a mechanism that has been designed especially to carry out frontal coupling and uncoupling movements of the doors of a vehicle to and from the corresponding door opening, specifically of the type in which said doors are moveable along runners, in their own plane, parallel to the bodywork of the vehicle, and capable of moving transversely, to fit into and to withdraw from the door opening.

**[0002]** The object of the invention is centred specifically on the mechanism with which the transverse movement of the doors is carried out, for their insertion into and withdrawal from the door opening.

**[0003]** The invention is applicable in the field of public transport vehicles, specifically for vehicles dedicated to passenger transport, such as trains, buses and similar, although it can be applied to any other door found in any other type of terrestrial, marine or air vehicle.

### BACKGROUND TO THE INVENTION

**[0004]** In the type of vehicles previously mentioned the use of sliding doors is common, for example a pair of doors that act against each other to close a single door opening of a width equivalent to the combined width of such doors, in such a way that, in the closing movement, these latter, for example, trace a trajectory parallel to the vehicle bodywork, or in other words, a prior movement in their own plane, to finally undergo a transverse movement with which they are fitted into the door opening. During the opening movement the doors are first withdrawn from the door opening, in a complementing manner, and afterwards they move in their own plane, by sliding on suitable guides, in the sense of moving apart, up to the fully open limit position.

**[0005]** Sliding doors of this type are described in the Spanish invention patent ES 2 073 669, in the European patent EP 0957019, in the PCT WO 01/85518 and in the European patent EP 0820889, among other documents.

**[0006]** All of them present as common denominator a notable structural complexity, especially as regards the mechanism with which the transverse movement of the doors is achieved, for their insertion into or withdrawal from the door opening, which has negative repercussions both at cost level and later at maintenance level.

**[0007]** FR-A-2795446 describes sliding doors with an activating mechanism thereof according to the preamble of claim 1.

### DESCRIPTION OF THE INTENTION

**[0008]** The invention proposes sliding doors with an activating mechanism which forms a structurally very simple solution and with full functional guarantees, re-

solving in a fully satisfactory way the problems previously set out.

**[0009]** The proposed invention refers to sliding doors with a door opening mechanism of the type in which the path of displacement of the doors forms an "L" path, or a 90° change of trajectory, consisting of an initial withdrawal perpendicular to the plane of the door and afterwards a second movement of separation of the doors, parallel to the same plane of the doors.

**[0010]** For this and more specifically the mechanism of the sliding doors of the invention, starting with the use of the classic longitudinal guide for displacement, also longitudinal, or by sliding of the doors, and with the use of a belt or similar as a means for drawing them longitudinally, centres its characteristics on the fact that the supports by means of which the doors slide on the guide are connected to the activating belt in these doors by means of two pivoting angular "L"-shaped connecting-rods, that define the three points for fixation to the doors, and the displacement mechanisms of these latter; articulately joined at their apex to runners respectively integral with the two parallel branches defined by the belt; each of these angular connecting-rods being in turn articulately joined at the free end of one of its branches, which could be the main branch, to the support of the corresponding door; whereas at the free end of its branch, for example the smaller, a pivot or roller is established, moveably guided on an auxiliary and corresponding guide, with an end section that has a sharp bend, suitable for bringing-about in the angular connecting-rod, in the end phase of closing of the doors, a swivelling in the angular connecting-rods that results in a pulling towards the interior of the door supports, together with the actual main guide, and parallel to the movement in the same direction of said doors, in order that these are inserted into the door opening, or withdrawn in the first case when a movement in the opposite sense is carried out, that is, the opening movement.

**[0011]** The most characteristic point of this mechanism is based on the crossing of the fixation points of said swivelling angular connecting-rods to the securing points on the activating belt, an action that brings-about the swivelling and rotation about the retaining axis of the anchoring points of said connecting-rods and with this the opening or extraction of said doors in the direction perpendicular to the plane defined by the doors.

### DESCRIPTION OF THE DRAWINGS

**[0012]** To supplement the description that is being carried out, and with the aim of leading to a better understanding of the characteristics of the invention, in agreement with a preferred example of its practical embodiment, as an integral part of said description it is accompanied by a set of drawings where in an illustrative and non limiting way, the following have been represented:

Figure 1.- Shows a plan schematic representation

of a system of sliding doors for vehicles according to the invention in the opening limit position for said doors.

Figure 2.- Shows a representation similar to Figure 1 in a closing intermediate phase of said doors.

Figure 3.- Shows another representation similar to that of the previous figures, now with the doors in the closed limit position.

Figure 4.- Shows an enlarged detail of figure 2 at the level of the mechanism of the invention.

Figure 5.- Shows a detail similar to that of the previous figure but corresponding to the position of the mechanism of figure 3.

### PREFERABLE EMBODIMENT OF THE INVENTION

[0013] In the figures depicted the sliding doors have been referenced by (1), displaceable parallel to the bodywork (2) of the vehicle and finally insertable into the door opening (3), doors that through ties (4) are connected to respective supports (5) moveable on a principal guide (6), that, as in the example of practical embodiment shown in the figures, can be double; a guide (6) through which the supports (5) are moveable with the assistance of a continuous belt (7), mounted on end pulleys (8) and activated by a driving element (9).

[0014] Each support (5) is connected with one of the sections of the belt (7) by means of an "L"-shaped angular connecting-rod (10), so that each connecting-rod (10) is joined, through an articulated joint (11), to a runner (12) integral with the corresponding section of the belt (7), at the same time that through the free end of its longest branch, for example, and with the assistance of another articulated joint (13), it connects to the corresponding support (5) being guided in its movement by the guides (15). At the free end of, for example, the shorter branch of each connecting-rod (10) a complementing pivot roller (14) or similar is established, that similarly freely moves in an auxiliary guide (16), which is parallel to the main guide (6) and with an internal end section that is bent obtusely outwards. In this way and by the combined action of the articulated joints (13) and guides (15) with the rollers (14) and guides (16) the angular connecting-rods (10) are in this way forced to swivel, as shown in figure 5, which brings with it a combined movement of the doors (1), of mutual approach to each other and of inward movement, that is, towards the position for fitting into the door opening (3).

[0015] The connecting-rods (18) assure the parallel opening and closing of the doors, these not meriting any further detailed technical explanation.

[0016] In accordance with this structure, the operation of the mechanism is as follows:

[0017] Starting from, for example, the opening limit po-

sition shown in figure 1, the starting of the motor (9) brings about the movement of said doors (1) in their own plane, up to the position shown in figure 2, in which the rollers (14) reach the bend established between the two sections of the auxiliary guides (16), while the articulated joints (13) pass along the guides (15).

[0018] From this moment the doors (1) continue moving in the direction of mutual approach, since the supports (5) can continue approaching each other; but at the same time the angular connecting-rods (10) swivel, that brings about a withdrawal of the supports (5) and consequent retraction of the doors (1) to the closed limit position shown in figure 3, in which the angular connecting-rods (10) cross each other, each runner (12) passing beyond the opposite runner (12'), in a stable position.

[0019] In the opening movement the belt (7) moves in the opposite direction to the previous one and the angular connecting-rods (10) are forced into a swivelling movement also in the opposite direction, that in the first case brings-about the outwards pushing of the supports (5) and of the guide (6) on which they move, with the consequent outwards pushing also of the doors (1), until reaching the position shown in figure 2, in which the doors (1) have sufficiently separated from the bodywork of the vehicle, and are in condition to complete their run, now in their own plane.

### Claims

- Sliding doors (1) with activating mechanism thereof, preferably for vehicles intended for the public passenger transport, such as trains, buses and similar, of the type in which said doors combine a longitudinal movement in their own plane, with a transverse movement for fitting into and withdrawal from the door opening; for which purpose said doors (1) have supports (5) that slide on a main guide (6) drawn by a suitably motorized belt (7); **characterised in that** each support (5) associated with the corresponding door (1) and sliding on the main guide (6), is connected to the motorized belt (7) at opposite points of the actual belt through twin angular connecting-rods (10), preferably "L"-shaped, each one joined to its corresponding door; connecting-rods that through their apexes (11) are articulately joined to each of the runners (12) drawn by the belt (7); runners (12) that when the doors meet, the following-on movement in the displacement of the belt does not stop, bringing-about this continuation of movement of the belt (7), the articulation of the angular connecting-rods (10) and with this the crossing between each other of the apexes (11) of each connecting-rod (10) and with this the movement of insertion and withdrawal of the doors.
- Sliding doors (1) with activating mechanism thereof according to claim 1, **characterised in that** the

guides (6), supports (5) and doors (1), are retractable or extendible in the movement of insertion or withdrawal by means of the action of the connecting-rods (10) activated by the belt (7).

3. - Sliding doors (1) with activating mechanism thereof according to claim 1 and 2, **characterised in that** through the free end of one of its branches, preferably the longest branch, it is articulately attached (13) to the corresponding support (5), it being planned that a pair of auxiliary guides (15) also participate in the mechanism, one for each angular connecting-rod (10), on which the articulated joints (13) are guided that link with the supports (5) and another pair of guides (16) with a section parallel in the main with the principal guide (6); a large teat or roller (14) freely moving in each of these auxiliary guides (16), established in the free end of the shortest branch of the angular connecting-rod (10), so that the auxiliary guides (16) maintain stable the angular position of the connecting-rods (10) during the displacement of the doors (1) in their own plane; and they combine said longitudinal displacement with a transverse swivelling movement in the closing end phase or in the initial opening phase, acting on the supports (5) to insert and to withdraw the doors (1) from the doors opening (3).
4. - Sliding doors (1) with activating mechanism thereof according to claim 1, **characterised in that** in the closing limit position for said doors (1), the runners (12-12') associated with two sections of the belt (7) and corresponding with the respective doors (1), mutually pass beyond each other, the angular connecting-rods (10) remaining crossed over each other.

#### Patentansprüche

1. Schiebetüren (1) mit Aktivierungsmechanismus derselben, vorzugsweise für Fahrzeuge, die für die öffentliche Personenbeförderung bestimmt sind, wie Züge, Busse und dergleichen, von dem Typ, bei dem die Türen eine Längsbewegung in ihrer eigenen Ebene mit einer Querbewegung zum Eintreten in die Türöffnung und zum Austreten aus derselben kombinieren, wobei die Türen (1) für diesen Zweck Träger (S) haben, die auf einer Hauptführung (6) gleiten, die von einem in geeigneter Weise motorgetriebenen Band (7) gezogen wird, **dadurch gekennzeichnet, dass** jeder Träger (5), der zu der entsprechenden Tür (1) gehört und auf der Hauptführung (6) gleitet, mit dem motorgetriebenen Band (7) an einander gegenüberliegenden Punkten des eigentlichen Bandes über Doppel-Winkelverbindungsstangen (10) verbunden ist, die vorzugsweise L-förmig sind, wobei jede von ihnen mit ihrer entsprechenden Tür verbunden ist und die Verbindungsstangen über ihre

Scheitelpunkte (11) gelenkig mit jedem der Läufer verbunden sind, die von dem Band (7) gezogen werden, wobei die Läufer (12), wenn die Türen aufeinander treffen und die Folgebewegung bei der Verschiebung des Bandes nicht unterbrochen wird, diese Fortsetzung der Bewegung des Bandes (7), die gelenkige Bewegung der Winkel-Verbindungsstangen (10) und damit das Überschneiden der Scheitelpunkte (11) jeder Verbindungsstange (10) und damit die Bewegung des Einfahrens und Ausfahrens der Türen bewirken.

2. Schiebetüren (1) mit Aktivierungsmechanismus derselben nach Anspruch 1, **dadurch gekennzeichnet, dass** die Führungen (6), Träger (5) und Türen (1) bei der Bewegung des Einfahrens oder Ausfahrens durch die Wirkung der Verbindungsstangen (10), die durch das Band (7) aktiviert werden, eingezogen oder ausgeschoben werden können.
3. Schiebetüren (1) mit Aktivierungsmechanismus derselben nach Anspruch 1 und 2, **dadurch gekennzeichnet, dass** er durch das freie Ende einer seiner Schenkel, vorzugsweise des längsten Schenkels, gelenkig (13) an dem entsprechenden Träger (5) angebracht ist, wobei vorgesehen ist, dass ein Paar Hilfsführungen (15) ebenfalls Teil des Mechanismus sind, d. h. eine Hilfsführung für jede Winkel-Verbindungsstange (10), an der die Gelenkverbindungen (13) geführt werden, die mit den Trägern (5) und einem weiteren Paar Führungen (16) mit einem Abschnitt im Wesentlichen parallel zu der Hauptführung (6) verbunden sind; wobei sich eine große Rolle (14) frei in jeder dieser Hilfsführungen (16) bewegt, die im freien Ende des kürzesten Schenkels der Winkel-Verbindungsstange (10) ausgebildet ist, so dass die Hilfsführungen (16) die Winkelposition der Verbindungsstangen (10) während der Verschiebung der Türen (1) in ihrer eigenen Ebene stabil halten und sie die Längsverschiebung mit einer Querschwenkbewegung in der Schließ-Endphase oder der Anfangs-Öffnungsphase kombinieren und auf die Träger (5) einwirken, um die Türen (1) in die Türöffnungen (3) einzufahren oder sie aus ihnen auszufahren.
4. Schiebetüren (1) mit Aktivierungsmechanismus derselben nach Anspruch 1, **dadurch gekennzeichnet, dass** in der Schließ-Grenzposition für die Türen (1) die Läufer (12, 12'), die mit zwei Abschnitten des Bandes (7) verbunden sind und den jeweiligen Türen (1) entsprechen, aneinander vorbei laufen, wobei die Winkel-Verbindungsstangen (10) einander weiter überkreuzen.

## Revendications

1. Portes coulissantes (1) avec leur mécanisme de commande, de préférence pour véhicules prévus pour le transport public des passagers tels que des trains, des bus et similaires, du type dans lequel de telles portes combinent un mouvement longitudinal dans leur propre plan avec un mouvement transversal pour l'insertion et le retrait de l'ouverture de porte ; pour lequel but, lesdites portes (1) ont des supports (5) qui coulisent sur un guide principal (6) tiré par une courroie motorisée (7) de manière appropriée ; **caractérisées en ce que** chaque support (5) associé à la porte (1) correspondante et coulisant sur le guide principal (6), est raccordé à la courroie motorisée (7) au niveau des points opposés de la véritable courroie par le biais de tiges de raccordement angulaires jumelées (10), de préférence en forme de « L », chacune reliée à sa porte correspondante; des tiges de raccordement qui par le biais de leur sommet (11) sont assemblées de manière articulée à chacun des galets (12) tirés par la courroie (7) ; des galets (12) qui lorsque les portes se rencontrent, le mouvement de poursuite dans le déplacement de la courroie ne s'arrête pas, provoquant cette continuation de mouvement de la courroie (7), l'articulation des tiges de raccordement angulaires (10) et avec ce croisement entre eux des sommets (11) de chaque tige de raccordement (10) et avec cela, le mouvement d'insertion et de retrait des portes.
 

5  
10  
15  
20  
25  
30
  
2. Portes coulissantes (1) avec leur mécanisme de commande selon la revendication 1, **caractérisées en ce que** les guides (6), les supports (5) et les portes (1) sont rétractables ou extensibles dans le mouvement d'insertion ou de retrait au moyen de l'action des tiges de raccordement (10) activées par la courroie (7).
 

35  
40
  
3. Portes coulissantes (1) avec leur mécanisme de commande selon les revendications 1 et 2, **caractérisées en ce que** par le biais de l'extrémité libre de l'une de ses branches, de préférence la branche la plus longue, elle est fixée de manière articulée (13) au support correspondant (5), on envisage qu'une paire de guides auxiliaires (15) participe également dans le mécanisme, chacun pour chaque tige de raccordement angulaire (10), sur lesquels les joints articulés (13) sont guidés, qui se relie avec les supports (5) et une autre paire de guides (16) avec une section parallèle dans l'ensemble avec le guide principal (6) ; un grand téton ou rouleau (14) se déplaçant librement dans chacun de ces guides auxiliaires (16), établi dans l'extrémité libre de la branche la plus courte de la tige de raccordement angulaire (10), de sorte que les guides auxiliaires (16) maintiennent stable la position angulaire des
 

45  
50  
55
  
- tiges de raccordement (10) pendant le déplacement des portes (1) dans leur propre plan; et elle combine ledit déplacement longitudinal avec un mouvement de pivotement transversal dans la phase d'extrémité de fermeture ou dans la phase d'ouverture initiale, agissant sur les supports (5) pour insérer ou retirer les portes (1) de l'ouverture (3) de porte.
 

5
  
4. Portes coulissantes (1) avec leur mécanisme de commande selon la revendication 1, **caractérisées en ce que** dans la position de limite de fermeture pour lesdites portes (1), les galets (12 - 12') associés avec deux sections de la courroie (7) et correspondant aux portes (1), respectives, passent mutuellement au-delà les uns des autres, les tiges de raccordement angulaires (10) restant croisées l'une sur l'autre.
 

10  
15  
20  
25  
30

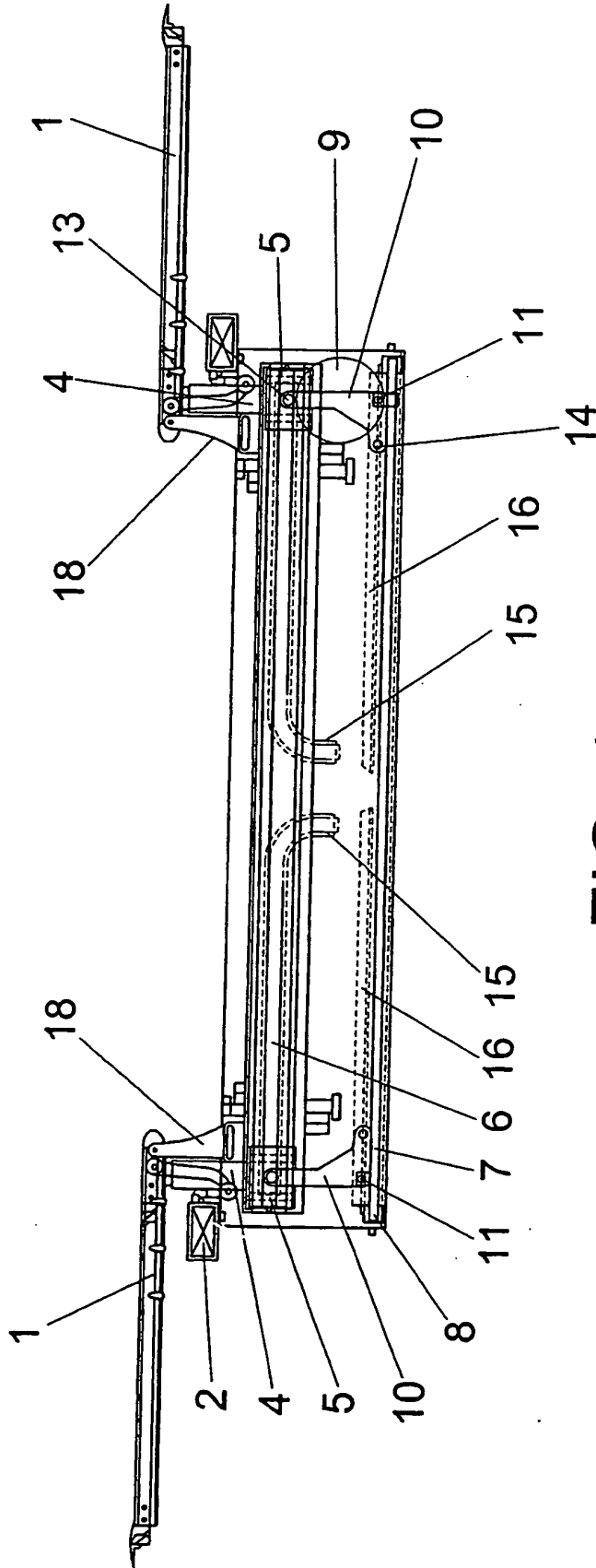

FIG. 1



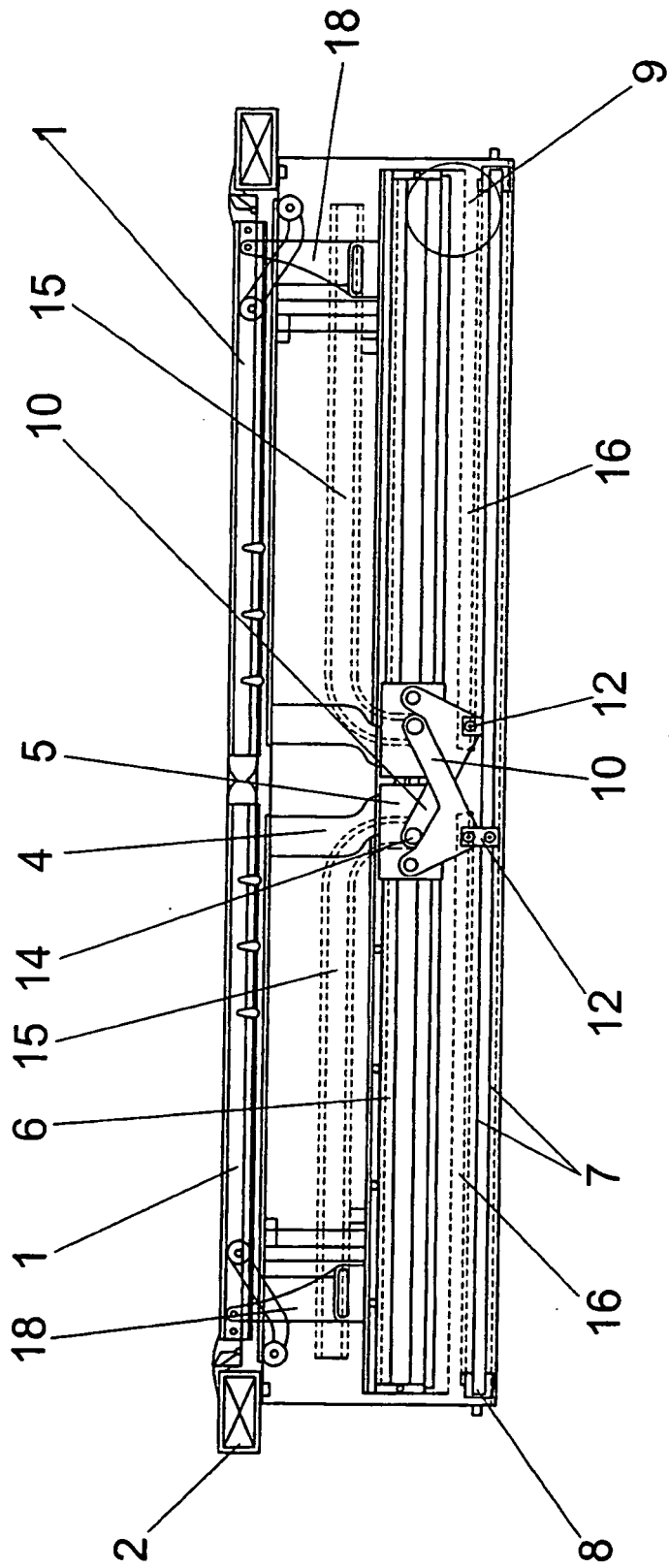

FIG. 3

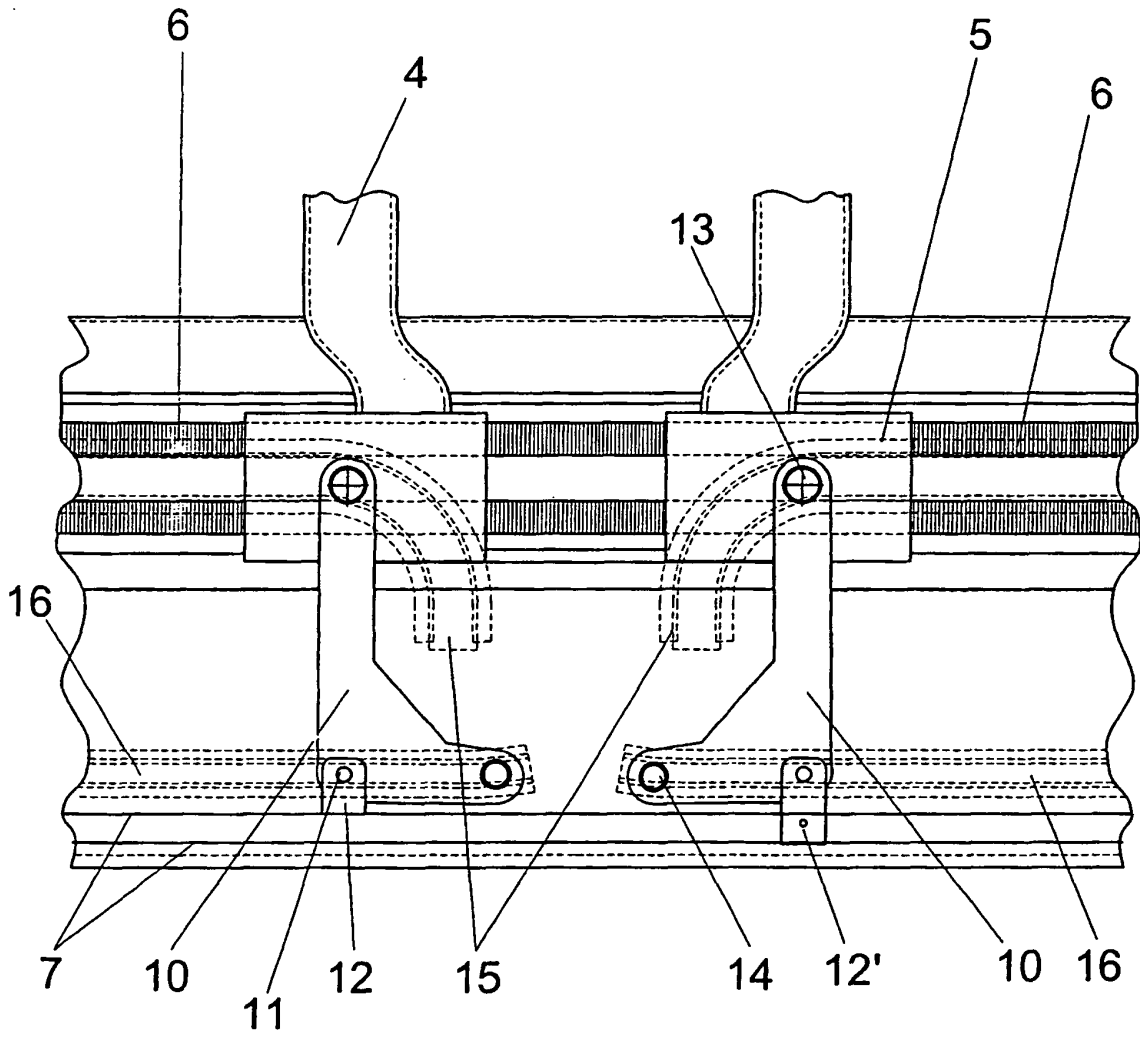

FIG. 4

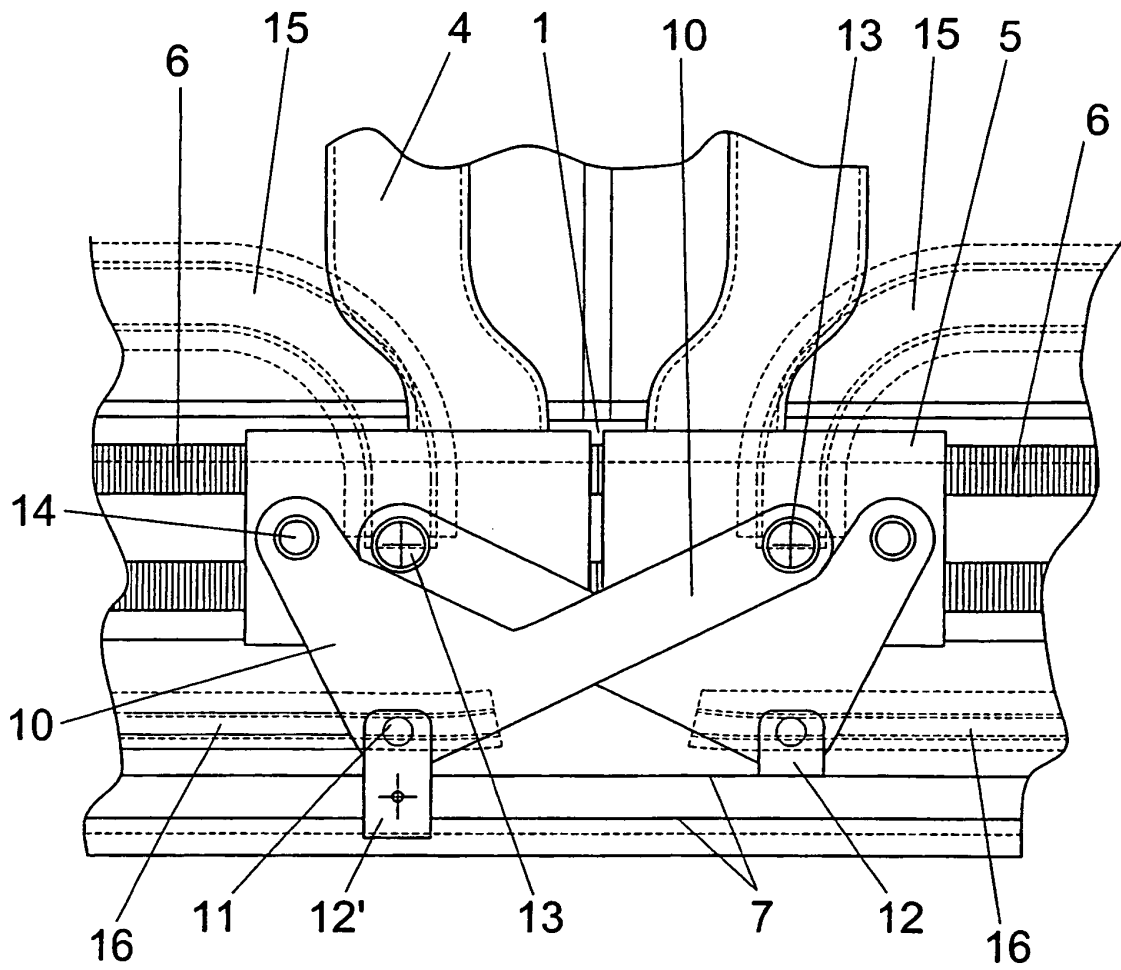

FIG. 5

**REFERENCES CITED IN THE DESCRIPTION**

*This list of references cited by the applicant is for the reader's convenience only. It does not form part of the European patent document. Even though great care has been taken in compiling the references, errors or omissions cannot be excluded and the EPO disclaims all liability in this regard.*

**Patent documents cited in the description**

- ES 2073669 [0005]
- EP 0957019 A [0005]
- WO 0185518 A [0005]
- EP 0820889 A [0005]
- FR 2795446 A [0007]