

Feb. 26, 1929.

1,703,249

T. O. SCHRADER

CLOSURE FASTENER

Filed March 11, 1927

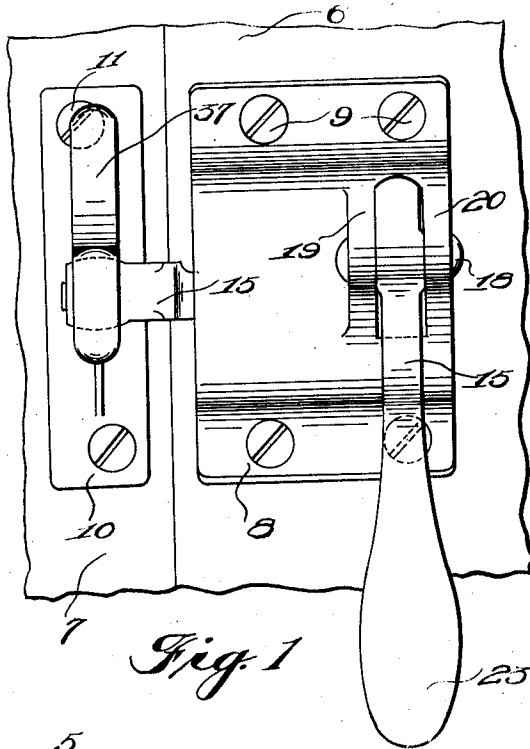

Fig. 1

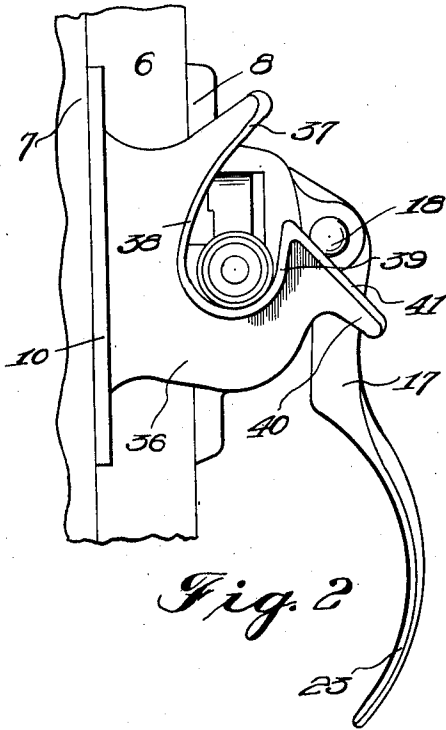

Fig. 2

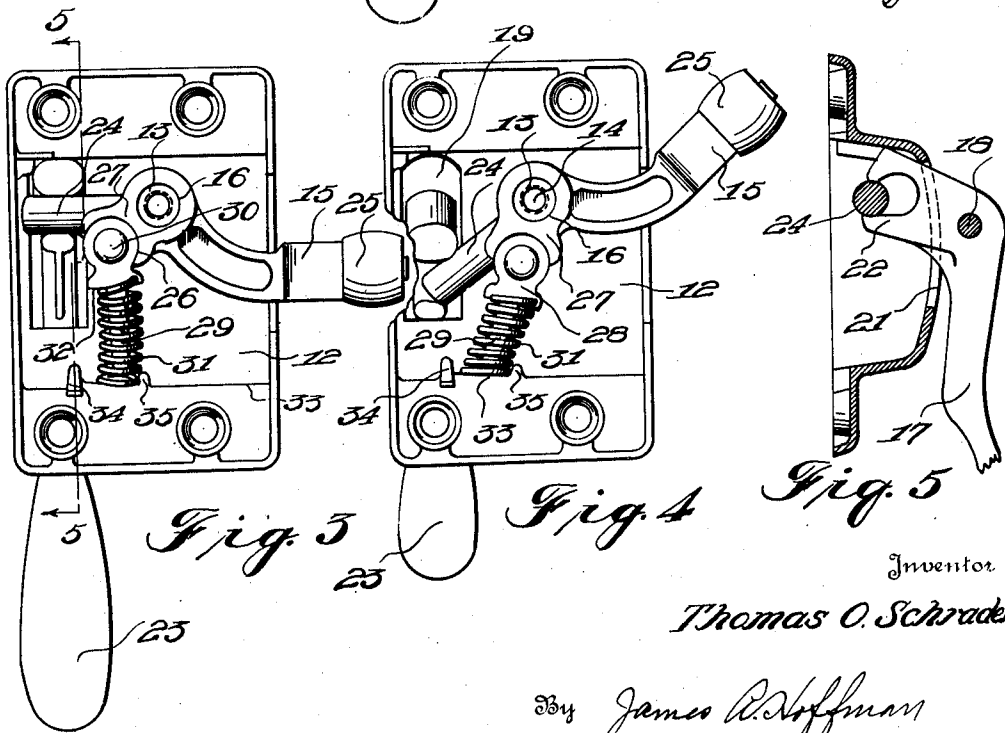

Fig. 3

Fig. 4

Fig. 5

Inventor

Thomas O. Schrader

By James R. Hoffman

Attorney

UNITED STATES PATENT OFFICE.

THOMAS O. SCHRADER, OF ALLENTOWN, PENNSYLVANIA, ASSIGNOR TO THE DENT
HARDWARE COMPANY, OF FULLERTON, PENNSYLVANIA, A CORPORATION OF
PENNSYLVANIA.

CLOSURE FASTENER.

Application filed March 11, 1927. Serial No. 174,570.

This invention relates to a closure fastener, especially designed for use in fastening refrigerator doors, though the device is capable of being used as a securing means for a closure of any kind.

A primary purpose of the invention is to provide a fastener including a bolt that is yieldingly urged to its operative position by a spring so arranged that when the bolt is withdrawn from the keeper the direction of thrust of the spring is changed with respect to the bolt pivot so that it serves to hold the bolt in its inoperative position.

A further object of the invention is to provide a fastener including a bolt that is yieldingly maintained in its elevated or inoperative position when the bolt is released, but which is automatically tripped by engagement with the keeper and springs to its latching position when the door is closed.

A further object of the invention is to provide a fastener, including a bolt that is caused to seek its operative position by engagement with the keeper when the door is closed, in which the bolt swings in a plane parallel to the face of the closure when tripped by the keeper and in which the swinging movement of the bolt causes the door to be seated tightly against its frame.

A further object of the invention is to provide a fastener in which the thrust of the spring is substantially toward the pivot of the bolt when the bolt is in position to be tripped by the keeper whereby the bolt will be readily actuated even though the door be closed without slamming. At the same time, the bolt does not ride over the keeper to compress and thus store energy in the bolt spring, but the keeper serves normally merely to move the bolt to a position where the line of thrust of the spring is directed to one side of the bolt pivot when the bolt snaps into its operative position in the keeper. The operation of a door equipped with this fastener may be substantially noiseless since no force need be applied to the door to cause the spring to be compressed before the bolt will spring to its latching position, or to release the bolt from its elevated position.

Further objects of the invention will appear as the description proceeds with reference to the accompanying drawings in which,

Fig. 1 is a front elevation of a portion of a closure and frame, such as a refrigerator

door and door frame, showing the fastener in operative position.

Fig. 2 is a fragmentary end elevation of the construction shown in Fig. 1.

Fig. 3 is a rear view of the fastener, the cover plate being removed to expose the interior thereof with the bolt in latching or operative position.

Fig. 4 is a view similar to Fig. 3 showing the bolt in raised or inoperative position.

Fig. 5 is a sectional view taken on the line 5—5 of Fig. 3 looking in the direction of the arrows.

Like reference numerals indicate like parts throughout the several views.

Numeral 6 indicates the free side of a hinged door, that in closed position engages a frame 7. The fastener indicated generally by the numeral 8 is secured to the door by suitable means, such as screws 9. A keeper 10 is attached to the frame in a suitable way, as by screws 11.

Fastener 8 comprises a casing 12 provided with an inwardly projecting pin 13, that may be bored and tapped, as shown at 14 to receive the screw that secures a cover plate (not shown) on the rear face of the fastener. A bolt 15 provided with an opening 16 between its ends to receive pin 13 is thus pivotally secured within casing 12. Bolt 15 is manually actuated by means of a lever 17 pivoted on a pin 18 that passes through aligned openings in spaced lugs 19 and 20 arranged on opposite sides of an opening 21 in casing 12. One end of lever 17 projects through opening 21 and is bifurcated as shown at 22 (Fig. 5). The other end of said lever is preferably shaped to form a handle 23.

Bolt 15 is provided with an arm, preferably cylindrical as shown at 24, the end of which extends between the furcations of lever 17. The end of bolt 15 that engages the keeper is provided with an antifriction roller 25 secured thereto in any suitable manner.

Pivoted in a recess 26 in a lateral extension 27 of bolt 15, adjacent the pivotal connection between the bolt and casing 12, is a link 28 having a reduced portion 29 extending away from pin 30 that pivotally secures the link 28 to said bolt. A spring 31 surrounds extension 29 and is arranged between shoulder 32 of said link and a wall 33 of casing 12. Lugs 34 and 35 prevent the spring from moving laterally a substantial distance.

The keeper 10 has a forwardly projecting portion 36 having a cam surface 37 formed in position to engage the end of bolt 15 as the door is closed and when the bolt is in raised position as shown in Fig. 4. Cam surface 37 is curved inwardly as shown at 38 so that as the roller 25 on the end of bolt 15 engages surface 37, the bolt is caused to move downwardly thus breaking the toggle formed by link 28 and extension 27 and causing the line of thrust of the spring to extend to one side of the pivot of bolt 15. Spring 31 then causes the bolt to swing on its pivot and snap downwardly behind an upward projection 39, spaced from surface 38 on keeper 10. The inner surface of said projection is inclined slightly toward the frame so that as the bolt snaps into position behind said projection the closure is pressed against the frame forming a tight joint between door and frame. Keeper 10 is also provided with a further forwardly projecting portion 40 having an inclined surface 41.

In operation, bolt 15 engages projection 39 of keeper 10 when the door is closed. To open the door, the handle 23 is grasped and swung about its pivot 18, thus causing the bolt 15 to swing about pivot pin 13. As the door is opened the bolt is swung from the position shown in Fig. 3 to that shown in Fig. 4. In the latter position the thrust of spring 31 is toward the pin 13, slightly to the right of the center of said pin viewing Fig. 4, so that the bolt remains in raised position. As the door is swung toward its closed position, the end of bolt 15 engages cam surface 37, breaking the toggle joint as above described, and thus causing spring 31 to snap the end of the bolt behind projection 39 thus firmly pressing the door against the frame. As the arrangement disclosed does not require that the spring be substantially compressed when it is tripped, it follows that it is unnecessary to forcibly close the door to trip the latch and cause it to operate. If for any reason, the bolt is released before the door is closed, surface 41 will function to raise the bolt after the manner of well known

spring pressed bolts. Normally the bolt is raised when the door is open, and a slight force will be sufficient to swing the door to closed position and cause the fastener to secure the door. It will thus be seen that a fastener is provided, involving no latch to hold the bolt in retracted position, which is simple in construction, and which may be tripped with certainty even if the door is closed gently.

The invention has been above described in considerable detail. It should be understood, however, that the invention does not reside in such detail, but that the scope thereof is to be determined from the following claims.

What I claim as my invention is:

1. A closure fastener comprising a casing, a bolt mounted within said casing to swing about a pivot, a laterally extending arm on said bolt, a link pivoted to said arm, an endwise extensible spring surrounding said link and arranged between an abutment on said link and an abutment on the side of said casing, the arm and link extending in a substantially straight line when the bolt is in its retracted position to form a toggle joint that may readily be broken when the bolt is moved from its retracted position.

2. A closure fastener comprising a casing, a bolt pivoted in said casing to swing about an axis at right angles to the plane of the closure face, an arm projecting laterally from the bolt pivot, a link pivoted to said arm, a coil spring surrounding said link and secured thereto at one end and abutting against said casing at its other end, the pivot between said arm and link being so disposed that the thrust of said spring is exerted substantially directly toward the bolt pivot when the bolt is in its retracted position and to one side of said last named pivot when the bolt is moved from said position, whereby said arm and link form a toggle joint that is broken when the bolt is moved from its retracted position toward its operative position.

In testimony whereof I affix my signature.
THOMAS O. SCHRADER.