



INTERNATIONAL APPLICATION PUBLISHED UNDER THE PATENT COOPERATION TREATY (PCT)

(51) International Patent Classification ⁶ : A61F 2/08	A1	(11) International Publication Number: WO 97/20522 (43) International Publication Date: 12 June 1997 (12.06.97)
<p>(21) International Application Number: PCT/GB96/02985</p> <p>(22) International Filing Date: 4 December 1996 (04.12.96)</p> <p>(30) Priority Data: 9524861.3 5 December 1995 (05.12.95) GB</p> <p>(71) Applicant (for all designated States except US): UNITED SURGICAL SERVICES LIMITED [GB/GB]; 12 Britannia Square, Worcester, Worcestershire WR1 3DG (GB).</p> <p>(72) Inventor; and (75) Inventor/Applicant (for US only): STROVER, Angus, Everett [GB/GB]; 12 Britannia Square, Worcester, Worcestershire WR1 3DG (GB).</p> <p>(74) Agents: HULSE, Thomas, Arnold et al.; Hulse & Co., Eagle Star House, Carver Street, Sheffield S1 4FP (GB).</p>	<p>(81) Designated States: AU, CA, JP, US, European patent (AT, BE, CH, DE, DK, ES, FI, FR, GB, GR, IE, IT, LU, MC, NL, PT, SE).</p> <p>Published <i>With international search report. Before the expiration of the time limit for amending the claims and to be republished in the event of the receipt of amendments.</i></p>	

(54) Title: SURGICAL ANCHORAGE

(57) Abstract

An anchorage device (12) for a ligament substitute (13) in a bone tunnel (14) has leading and trailing limbs (15, 16) with eyes (20) for temporary attachment of pulling threads (21, 23), and a body part (17) providing a loop (18) for attachment of the ligament substitute, as by a link (19), the overall lateral width (W) of the device (12) being less than the diameter (D) of the bone tunnel (14), to enable the device to be pulled through by the leading pulling thread (21), the overall length (L) of the device being greater than the diameter (D) of the bone tunnel, to enable the device to span the distal end (22) of the bone tunnel, and the breadth (B) of the body part (17) being less than the diameter (D) of the bone tunnel, to enable the body part to locate in the distal end of the bone tunnel when the device spans the distal end of the bone tunnel.

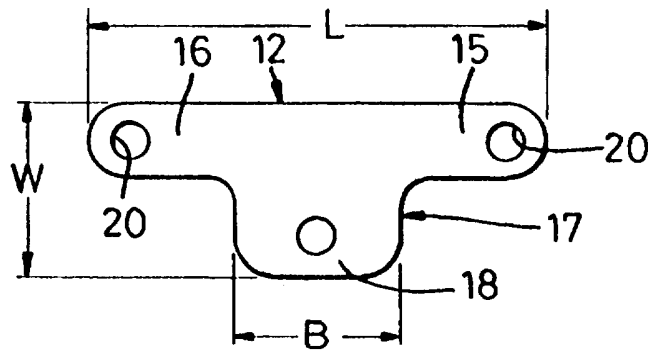

FOR THE PURPOSES OF INFORMATION ONLY

Codes used to identify States party to the PCT on the front pages of pamphlets publishing international applications under the PCT.

AM	Armenia	GB	United Kingdom	MW	Malawi
AT	Austria	GE	Georgia	MX	Mexico
AU	Australia	GN	Guinea	NE	Niger
BB	Barbados	GR	Greece	NL	Netherlands
BE	Belgium	HU	Hungary	NO	Norway
BF	Burkina Faso	IE	Ireland	NZ	New Zealand
BG	Bulgaria	IT	Italy	PL	Poland
BJ	Benin	JP	Japan	PT	Portugal
BR	Brazil	KE	Kenya	RO	Romania
BY	Belarus	KG	Kyrgystan	RU	Russian Federation
CA	Canada	KP	Democratic People's Republic of Korea	SD	Sudan
CF	Central African Republic	KR	Republic of Korea	SE	Sweden
CG	Congo	KZ	Kazakhstan	SG	Singapore
CH	Switzerland	LI	Liechtenstein	SI	Slovenia
CI	Côte d'Ivoire	LK	Sri Lanka	SK	Slovakia
CM	Cameroon	LR	Liberia	SN	Senegal
CN	China	LT	Lithuania	SZ	Swaziland
CS	Czechoslovakia	LU	Luxembourg	TD	Chad
CZ	Czech Republic	LV	Latvia	TG	Togo
DE	Germany	MC	Monaco	TJ	Tajikistan
DK	Denmark	MD	Republic of Moldova	TT	Trinidad and Tobago
EE	Estonia	MG	Madagascar	UA	Ukraine
ES	Spain	ML	Mali	UG	Uganda
FI	Finland	MN	Mongolia	US	United States of America
FR	France	MN	Mongolia	UZ	Uzbekistan
GA	Gabon	MR	Mauritania	VN	Viet Nam

5 SURGICAL ANCHORAGE

This invention relates to a surgical anchorage for a ligament (or tendon) substitute or replacement, which may consist of artificial material such as polyester fabric, or natural material such as autogenous tendon or allogenic ligament or tendon, hereinafter referred to simply as a ligament substitute.

10 A ligament substitute for a knee is introduced into the joint through bone tunnels or bores through the tibia and femur located to open into the cavity of the knee joint at the anatomical attachment site of the natural ligament, and the ligament substitute is anchored or attached firmly within or at the distal ends of the bone tunnels.

Anchorage or fixation within the bone tunnels may be provided, for instance, by the
15 following methods:-

1. a suture tape or wire attached to the ligament substitute and tied to a screw or a bollard which is placed through the outer cortical surface of the bone and anchored in a drill hole through the bone.
2. an "interference screw" which holds the ligament substitute by interference of the
20 screw threads between the bony wall of the tunnel and the ligament substitute.
3. the use of sutures or tape through the ligament substitute and tied through a "button" or over a "toggle" placed across the end of the bone tunnel.

With respect to minimally-invasive surgery, disadvantages of the above are the following:-

1. Anchorage to a bollard or screw requires drilling through the cortex of the bone at right
25 angles to the direction of the bone tunnel transmitting the ligament or tendon substitute. This additional drill hole can substantially weaken the bone. This method of anchorage requires a separate skin incision to expose the bone. In this way it increases the invasive nature of the operation, the remainder of which can be performed by a minimally- invasive or endoscopic

5 technique.

2. An interference screw which is positioned alongside a tendon graft or ligament substitute can hold it firmly against the cancellous bone on the side of a bone tunnel. This method suffers the disadvantage of possible damage to the ligament substitute. It also deforms the area of attachment of the ligament substitute with the danger of creating biomechanical inaccuracy of the constraint which is intended to be created by the ligament substitute. Most
10 interference screws are manufactured in metal, which creates artifactual distortion of magnetic resonance (MR) images. Since ligaments and soft tissues are best seen by MR imaging, a further disadvantage of interference screw fixation is MR image distortion in the postoperative period. This means that the assessment of subsequent injuries becomes difficult after
15 interference screw fixation. A further disadvantage of interference screw fixation is the difficulty encountered when an interference screw needs to be removed for purposes of revising the operation, should failure or reinjury occur.

3. When a ligament substitute is tied to a button at the external aperture of the drill hole in bone, the surgical procedure usually requires an additional incision to gain access to the bone
20 at the distal end of the drill hole.

An endoscopic or minimally-invasive technique using an "Endobutton" is known. This involves making the distal femoral hole in two different diameters, the proximal part being large enough to accommodate the ligament substitute, and the distal part being small enough to take the endobutton on its side, but not large enough to allow it to return down the hole after it has
25 been manipulated to lie transversely across the end of the drill hole. The surgical technique involves placing threads through holes in the extremities of the bar-shaped Endobutton, which is tied to the graft by means of a tape or strong sutures through a pair of holes at the middle of the Endobutton. The assembly is then attached to a long needle or sharpened guide wire which

5 is introduced and passed into the tibial end of the drill hole, and through the soft tissues of the thigh. The threads attached to the extremities of the Endobutton are used to manipulate the Endobutton into position on the femoral cortex at the distal end of the drill hole. The procedure is difficult as it involves careful planning of the lengths of drill holes and of the tape required to match these lengths. It involves pulling the guide sutures on the Endobutton one at a time to
10 manipulate it into position across the mouth of the drill hole. This procedure has to be performed either "blind" or by the use of X-rays with image intensification which is expensive and time-consuming.

The object of the present invention is to provide an anchorage device for a ligament substitute in a bone tunnel for use with a minimally-invasive surgical technique without the
15 disadvantages associated with any of the above methods and devices.

According to the present invention, an anchorage device for a ligament substitute in a bone tunnel comprises leading and trailing limbs in general alignment with each other, and a body part laterally offset from the leading and trailing limbs; the body part providing a loop for attachment of the ligament substitute; and each of the limbs having an eye, for temporary attachment of
20 pulling threads; the overall lateral width of the device being less than the diameter of the bone tunnel, to enable the device to be pulled through the bone tunnel by a pulling thread temporarily attached to the leading limb; the overall length of the device between the remote ends of the limbs being greater than the diameter of the bone tunnel, to enable the device to span the distal end of the bone tunnel; and the breadth of the body part in the lengthwise direction of the limbs
25 being less than the diameter of the bone tunnel, to enable the body part to locate in the distal end of the bone tunnel when the device spans the distal end of the bone tunnel.

The device is preferably symmetrical about an imaginary line perpendicular to the limbs at the middle of the loop of the body part, so that either limb can be the leading limb or the trailing

5 limb.

The device may be formed from a single length of small diameter rod or wire (e.g. of stainless steel), with a mid-portion bent to form a substantially semicircular loop, from the ends of which the leading and trailing limbs extend respectively in opposite directions in substantially axial alignment with each other, and the remote ends of the limbs are curled to form substantially
10 circular eyes; alternatively, the mid-portion may be bent almost into a full circle, from the spaced ends of which the end portions of wire are bent away from but in axial alignment with each other, to form the leading and trailing limbs, with curled eyes at their respective remote ends; again, the mid-portion may be coiled to form a full circular loop, from the overlapping ends of which the leading and trailing limbs continue tangentially in opposite directions to curled eyes at their
15 remote ends.

Alternatively, the device may be formed from two (or more) lengths of rod or wire, one length being straight except for curled eyes at the remote ends of the limbs constituted by that length, while the other length is bent into a semicircular loop, the ends of which are welded symmetrically to the straight length; or the other length is bent into a full or an almost full
20 circular loop, the ends of which are welded symmetrically to the straight length; or, again, the other length may be bent into a full circle, the mating ends of which are welded to each other and to the middle of the straight length.

The eyes preferably both lie in the same general plane as the body part, loop and limbs, and both preferably extend laterally from the limbs to the same side as the body part and
25 loop, so as to avoid any protrusion liable to snag on the proximal end of the bone tunnel.

A device in accordance with the invention may alternatively be formed in one piece in biocompatible rigid plastics material or ceramic, or by stamping or otherwise cutting out from metal plate (e.g., of stainless steel or titanium).

5 The surgical technique using the device of the invention comprises attaching pulling threads to the eyes of the limbs, attaching a ligament substitute to the loop of the body part, threading the pulling thread attached to the leading limb through the bone tunnel from its proximal end by means of, for example, a needle-like tool of sufficient length until it emerges from the distal end of the bone tunnel and through the muscles, soft tissue and skin beyond, then pulling the device
10 through the bone tunnel by means of the thread attached to the leading limb (possibly assisted by pushing the device by means of, for example, a tubular or semi-tubular introducer fitting on to the trailing limb and furnished with a handle) with the ligament substitute trailing from the loop of the body part and the other pulling thread trailing from the trailing limb, until the device emerges completely beyond the distal end of the bone tunnel, then by pulling on the ligament
15 substitute in the opposite direction to the leading pulling thread, which is released, the device becomes reorientated spanning the distal end of the bone tunnel, and further slight pulling on the ligament substitute pulls the body part into the bone tunnel to secure it and the ligament substitute in position.

 It will be appreciated that the device will be initially aligned longitudinally relative to the
20 bone tunnel by initial traction of the leading pulling thread through the bone tunnel, and/or by propulsion of the device by means of the introducer engaged with the trailing limb.

 During the operative procedure the device can be released, if need be, by pulling on the leading thread until the device is pulled far enough from the distal end of the bone tunnel for pulling on the trailing thread in opposition to pulling on the leading thread to again align the
25 device longitudinally relative to the bone tunnel, whereafter continued pulling of the trailing thread (after releasing the leading thread) retracts the device with the ligament substitute and the leading thread (now trailing) back through the bone tunnel.

 The device may be attached to the ligament substitute by looping the latter round the loop

5 of the body part or by means of sutures or threads, and the latter may be remove to release the device from the ligament substitute when biological attachment has occurred, or the sutures or threads may be bioabsorbable. Again, the ligament substitute may be looped round one end of a link the other end of which is looped round the loop of the body part.

10 The loop in the body of the device may be incomplete (i.e., formed with a gap), to enable sutures or threads connecting it to a ligament substitute to be released by tilting the device (i.e., until the sutures or threads pass through the gap).

Embodiments of the invention will now be described, by way of example only, with reference to the accompanying diagrammatic drawings, all of which are approximately four times normal size and in which:-

15 Figure 1 is a side elevation of a preferred form of anchorage device in accordance with the invention;

Figure 2 is an end elevation of the device of Figure 1;

Figure 3 is a side elevation of a link for use with the device of Figures 1 and 2;

20 Figure 4 is a fragmentary section along a bone tunnel showing the device of Figures 1 and 2 and the link of Figure 3 in use to pull a ligament substitute through a bone tunnel;

Figure 5 corresponds to Figure 4 but shows the position of the device upon emerging from the bone tunnel;

Figure 6 also corresponds to Figure 4 but shows the device in position anchoring the ligament substitute; and

25 Figures 7 to 11 inclusive are side elevations of alternative embodiments of anchorage devices in accordance with the invention, all made with rod or wire.

In Figures 1 to 6, an anchorage device 12 for a ligament substitute 13 in a bone tunnel 14 comprises leading and trailing limbs 15, 16 in general alignment with each other, and a body part

5 17 having a loop 18 for attachment of the ligament substitute, as by looping the ligament substitute round one end of a link 19 the other end of which is looped round the loop of the body part, and each of the limbs having an eye 20 for temporary attachment of pulling threads.

The overall lateral width W of the device 12 less than the diameter D of the bone tunnel 14, to enable the device to be pulled through the bone tunnel by a pulling thread 21 temporarily
10 attached to the leading limb 15 (see Figure 4), the overall length L of the device between the remote ends of the limbs is greater than the diameter of the bone tunnel to enable the device to span the distal end 22 of the bone tunnel (see Figure 6), and the breadth B of the body part 17 in the lengthwise direction of the limbs is less than the diameter of the bone tunnel, to enable the body part to locate in the distal end of the bone tunnel when the device spans the distal end of the
15 bone tunnel.

The device 12 is symmetrical about an imaginary line perpendicular to the limbs 15, 16 at the middle of the loop 18, so that either limb can be the leading limb or the trailing limb.

The device 12 shown in Figures 1 to 6 is formed in one piece in biocompatible rigid plastics material or ceramic, or from metal plate such as stainless steel or titanium.

20 Before the device 12 is pulled into the bone tunnel 14, a pulling thread 23 is attached to the trailing limb 16 for a purpose to be described presently.

The device is pulled into and through the bone tunnel by threading the pulling thread 21 attached to the leading limb 15 through the bone tunnel from its proximal end (not shown) by means of, for example, a needle-like tool (not shown) of sufficient length until it emerges from
25 the distal end 22 of the bone tunnel and through the muscles, soft tissue and skin beyond (none of which is shown), with the ligament substitute 13 trailing from the link 19 which itself trails from the loop 18 of the body part 17 of the anchorage device 12. The pulling thread 23 attached to the trailing limb 16 trails slackly therefrom.

5 Pulling of the device 12 through the bone tunnel 14 may be assisted by pushing the device by means of, for example, a tubular or semi-tubular introducer (not shown) fitting on the trailing limb and furnished with a handle.

10 Without such assistance, and as indicated in Figure 4, the pull on the leading pulling thread 21 (which pull is indicated by the arrow 24) and the drag on the ligament substitute 13 (which drag is indicated by the broken arrows 25) imposes a moment on the device 12 such that the end of the trailing limb 16 rides along the wall of the bone tunnel 14 until, as the device emerges from the distal end 22 of the bone tunnel, the device rotates farther under the influence of that moment and brings the end of the trailing limb on to the bone surface adjacent the distal end of the bone tunnel, as shown in Figure 5.

15 Then, by pulling on the ligament substitute 13 in the opposite direction to the leading pulling thread 21, which is released, (and which pull on the ligament substitute is indicated by the arrows 26 in Figure 6) the device becomes reorientated spanning the distal end 22 of the bone tunnel 14 with the body part 17 pulled into the bone tunnel to secure it and the ligament substitute 13 in position.

20 If during the operative procedure, the device needs to be released, this can be effected by pulling on the leading thread 21 until the device is pulled far enough from the distal end 22 of the bone tunnel 14 for pulling on the trailing thread 23 in opposition to pulling on the leading thread aligns the device again longitudinally relative to the bone tunnel, whereafter continued pulling of the trailing thread (after releasing the leading thread) retracts the device with the ligament substitute and the leading thread (now trailing) back through the bone tunnel.

25

 Alternatively to the link 19, the device 12 may be attached to the ligament substitute 13 by means of sutures or threads (not shown), and the latter may be cut to release the device from the ligament substitute when biological attachment has occurred, or the sutures or threads may

5 be bioabsorbable.

A link or sutures or threads may be used to attach to a ligament substitute any one of the alternative devices shown in Figures 7 to 11 made from small diameter rod or wire, or the ligament may be looped directly round the loop 18 of the respective body part 17.

10 In Figure 7 the device 12 is formed from a single length of rod or wire (e.g. of stainless steel) with a mid-portion 17 bent to form a substantially semicircular loop 18 from the ends of which the leading and trailing limbs 15, 16 extend respectively in opposite directions in substantially axial alignment with each other, and the remote ends of the limbs are curled to form substantially circular eyes 20.

15 Alternatively, and as shown in Figure 8, a single length of rod or wire, may be bent almost into a full circle forming the body part 17 and loop 18, from the spaced ends of which the end portions of wire are bent away from each other to form the limbs 15, 16, with curled eyes 20 at their respective remote ends, and the bends 27, 28 are shown welded together.

20 Again, and as shown in Figure 9, the mid-portion 17 of a single length of rod or wire may be coiled to form a full circular loop 18, from the overlapping ends of which the leading and trailing limbs 15, 16 continue tangentially in opposite directions to curled eyes 20 at their remote ends.

25 In Figures 10 and 11 the devices 12 are each formed from two lengths of rod or wire, one length 29 being straight except for curled eyes 20 at the remote ends of the limbs 15, 16 constituted by that length, while the other length 17 is bent to provide a semicircular loop 18, the ends 30 of which are welded symmetrically to the straight length, as shown in Figure 10, or, as shown in Figure 11, the other length 17 is bent to provide a full (or almost full) circular loop 18 the ends 31 of which are welded symmetrically to the straight length.

The eyes 20 of the wire devices 12 both lie in the same general plane as the body part 17,

5 loop 18 and limbs 15, 16 and both extend laterally from the limbs to the same side as the body part and loop, so as to avoid any protrusion liable to snag on the proximal end of the bone tunnel.

5 CLAIMS

1. An anchorage device for a ligament substitute in a bone tunnel comprising leading and trailing limbs in general alignment with each other, and a body part laterally offset from the leading and trailing limbs; the body part providing a loop for attachment of the ligament substitute; and each of the limbs having an eye, for temporary attachment of pulling threads;
10 the overall lateral width of the device being less than the diameter of the bone tunnel, to enable the device to be pulled through the bone tunnel by a pulling thread temporarily attached to the leading limb; the overall length of the device between the remote ends of the limbs being greater than the diameter of the bone tunnel, to enable the device to span the distal end of the bone tunnel; and the breadth of the body part in the lengthwise direction of the limbs being less than
15 the diameter of the bone tunnel, to enable the body part to locate in the distal end of the bone tunnel when the device spans the distal end of the bone tunnel.

2. A device as in Claim 1, the device being symmetrical about an imaginary line perpendicular to the limbs at the middle of the loop of the body part, so that either limb can be the leading limb or the trailing limb.

20 3. A device as in Claim 1 or Claim 2, the device being formed from a single length of small diameter rod or wire with a mid-portion bent to form a substantially semicircular loop, from the ends of which the leading and trailing limbs extend respectively in opposite directions in substantially axial alignment with each other, and the remote ends of the limbs are curled to form substantially circular eyes.

25 4. A device as in Claim 1 or Claim 2, the device being formed from a single length of small diameter rod or wire with a mid-portion bent almost into a full circle, from the spaced ends of which the end portions of wire are bent away from but in axial alignment with each other, to form the leading and trailing limbs, with curled eyes at their respective remote ends.

5 5. A device as in Claim 1 or Claim 2, the device being formed from a single length of small diameter rod or wire with a mid-portion coiled to form a full circular loop, from the overlapping ends of which the leading and trailing limbs continue tangentially in opposite directions to curled eyes at their remote ends.

10 6. A device as in Claim 1 or Claim 2, the device being formed from two lengths of rod or wire, one length being straight except for curled eyes at the remote ends of the limbs constituted by that length, while the other length is bent into a semicircular loop, the ends of which are welded symmetrically to the straight length.

15 7. A device as in Claim 1 or Claim 2, the device being formed from two lengths of rod or wire, one length being straight except for curled eyes at the remote ends of the limbs constituted by that length while the other length is bent into a full or an almost full circular loop, the ends of which are welded symmetrically to the straight length.

 8. A device as in Claim 7, wherein the mating ends of the full circle are welded to each other as well as to the middle of the straight length.

20 9. A device as in any one of Claims 3 to 8, the device being formed from stainless steel rod or wire.

 10. A device as in any one of Claims 3 to 9 wherein the eyes both lie in the same general plane as the body part, loop and limbs, and both extend laterally from the limbs to the same side as the body part and loop, so as to avoid any protrusion liable to snag on the proximal end of the bone tunnel.

25 11. A device as in Claim 1 or Claim 2, the device being formed in one piece in a biocompatible rigid plastics material or ceramic.

 12. A device as in Claim 1 or Claim 2, the device being stamped or otherwise cut out from metal plate.

- 5
13. A device as in Claim 12, wherein the metal is stainless steel.
 14. A device as in Claim 12, wherein the metal is titanium.
 15. A device as in any one of Claims 4 or Claims 11 to 14, wherein the loop in the body of the device is incomplete, to enable sutures or threads connecting it to a ligament substitute to be released by tilting the device.

1/3

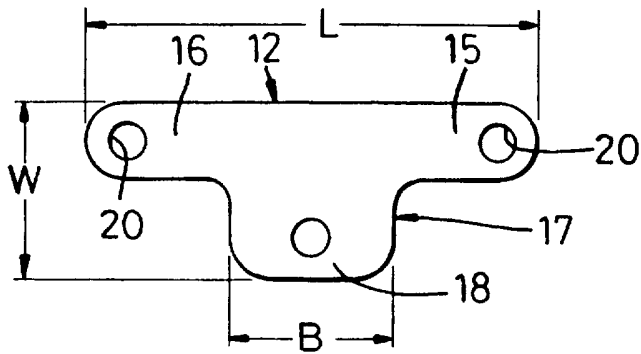

Fig. 1

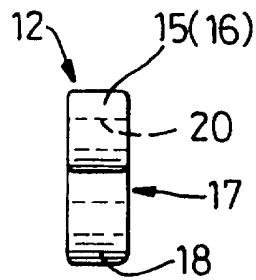

Fig. 2

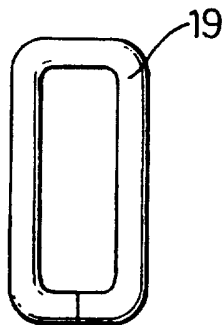

Fig. 3

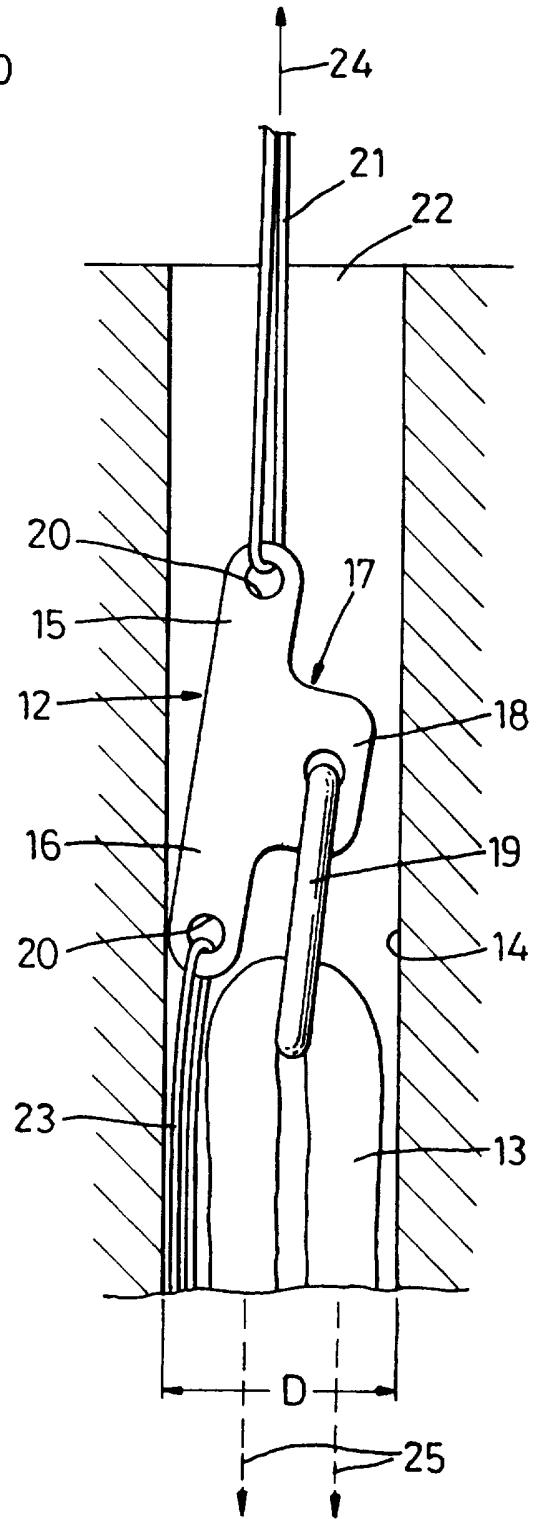

Fig. 4

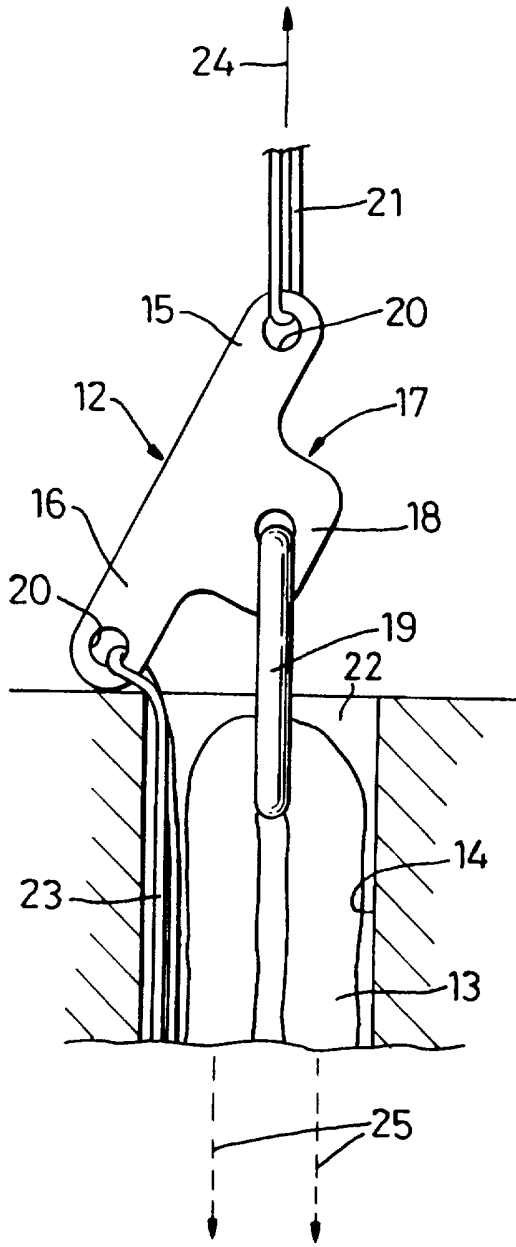

Fig. 5

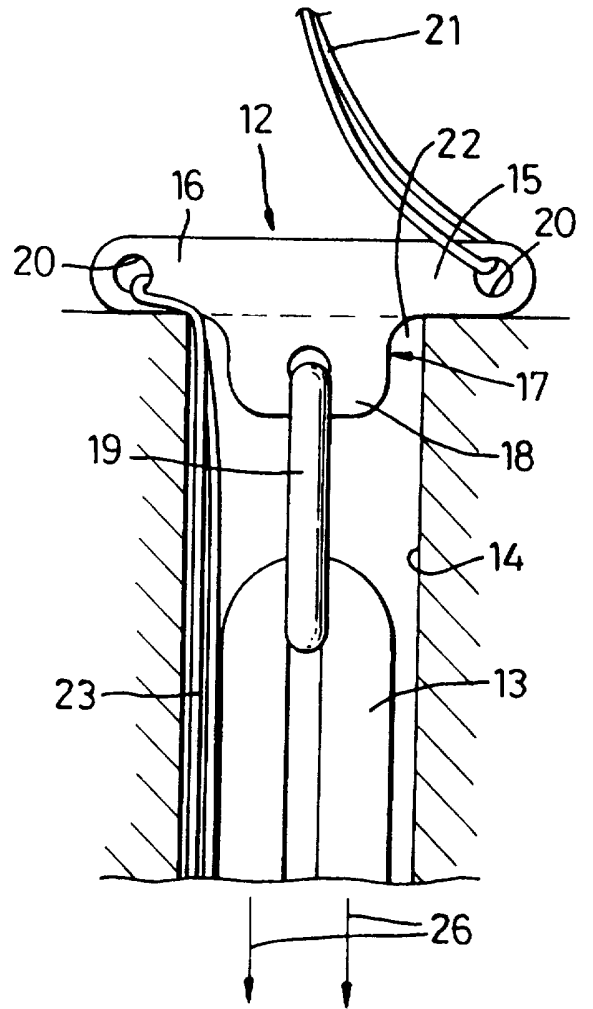

Fig. 6

3/3

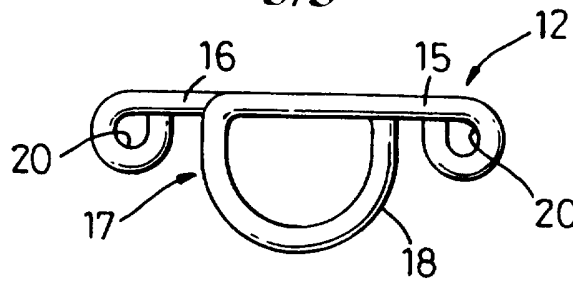

Fig. 7

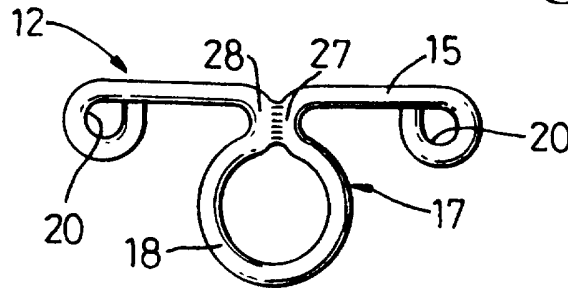

Fig. 8

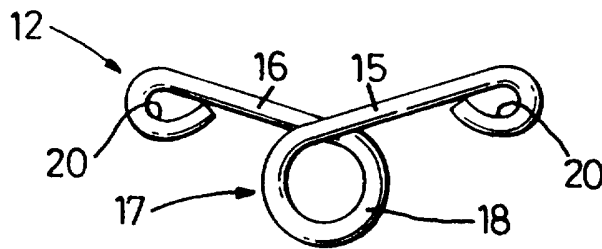

Fig. 9

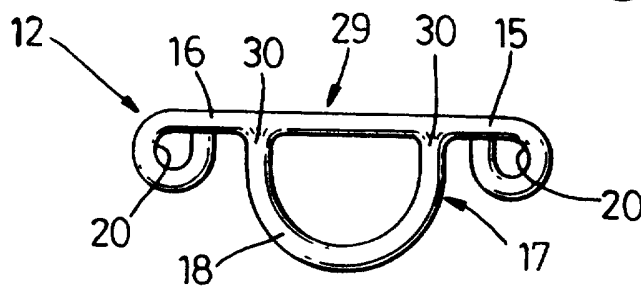

Fig. 10

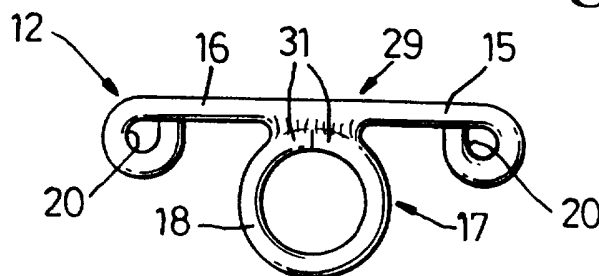

Fig. 11

INTERNATIONAL SEARCH REPORT

International Application No
PCT/GB 96/02985

A. CLASSIFICATION OF SUBJECT MATTER IPC 6 A61F2/08		
According to International Patent Classification (IPC) or to both national classification and IPC		
B. FIELDS SEARCHED		
Minimum documentation searched (classification system followed by classification symbols) IPC 6 A61F A61B		
Documentation searched other than minimum documentation to the extent that such documents are included in the fields searched		
Electronic data base consulted during the international search (name of data base and, where practical, search terms used)		
C. DOCUMENTS CONSIDERED TO BE RELEVANT		
Category *	Citation of document, with indication, where appropriate, of the relevant passages	Relevant to claim No.
X	US 5 306 301 A (GRAF BEN K ET AL) 26 April 1994 see column 3, line 49 - line 62; figures see column 5, line 22 - line 42 see column 6, line 24 - line 38 ---	1,2,11
A	GB 2 288 739 A (CORIN MEDICAL LTD) 1 November 1995 see page 3 - page 8; figures ---	1,11
A	FR 2 696 338 A (PERRIN MAX) 8 April 1994 see figures -----	1
<input type="checkbox"/> Further documents are listed in the continuation of box C. <input checked="" type="checkbox"/> Patent family members are listed in annex.		
* Special categories of cited documents :		
A document defining the general state of the art which is not considered to be of particular relevance *E* earlier document but published on or after the international filing date *L* document which may throw doubts on priority claim(s) or which is cited to establish the publication date of another citation or other special reason (as specified) *O* document referring to an oral disclosure, use, exhibition or other means *P* document published prior to the international filing date but later than the priority date claimed	*T* later document published after the international filing date or priority date and not in conflict with the application but cited to understand the principle or theory underlying the invention *X* document of particular relevance; the claimed invention cannot be considered novel or cannot be considered to involve an inventive step when the document is taken alone *Y* document of particular relevance; the claimed invention cannot be considered to involve an inventive step when the document is combined with one or more other such documents, such combination being obvious to a person skilled in the art. *&* document member of the same patent family	
Date of the actual completion of the international search <div style="text-align: center; font-size: 1.2em;">3 April 1997</div>	Date of mailing of the international search report <div style="text-align: center; font-size: 1.2em;">14.04.97</div>	
Name and mailing address of the ISA European Patent Office, P.B. 5818 Patentlaan 2 NL - 2280 HV Rijswijk Tel. (+ 31-70) 340-2040, Tx. 31 651 epo nl, Fax: (+ 31-70) 340-3016	Authorized officer <div style="text-align: center; font-size: 1.2em;">Neumann, E</div>	

INTERNATIONAL SEARCH REPORT

International Application No
PCT/GB 96/02985

Patent document cited in search report	Publication date	Patent family member(s)	Publication date
US 5306301 A	26-04-94	NONE	
GB 2288739 A	01-11-95	NONE	
FR 2696338 A	08-04-94	NONE	