

Oct. 26, 1965

T. C. SHIRLEY
CLEANING IMPLEMENT HAVING AN IMPROVED HAND GRIP PORTION
AND MOP HEAD SECURING MEANS
Filed Feb. 11, 1963

3,213,475

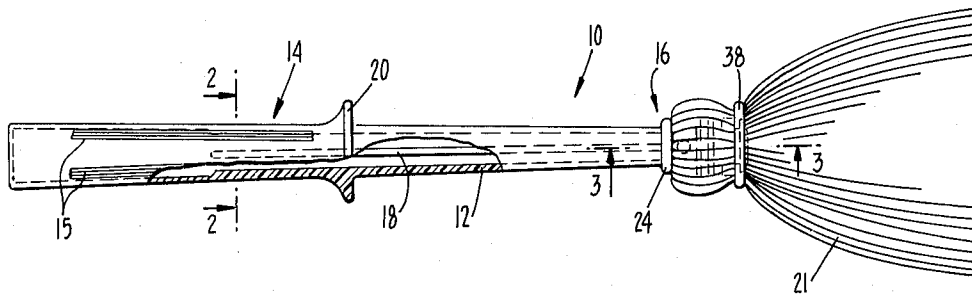

Fig. 1.

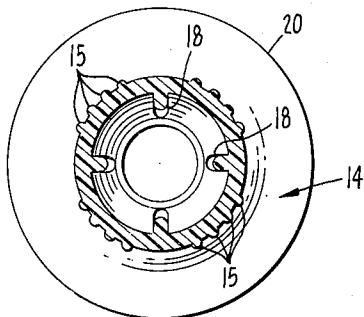

Fig. 2.

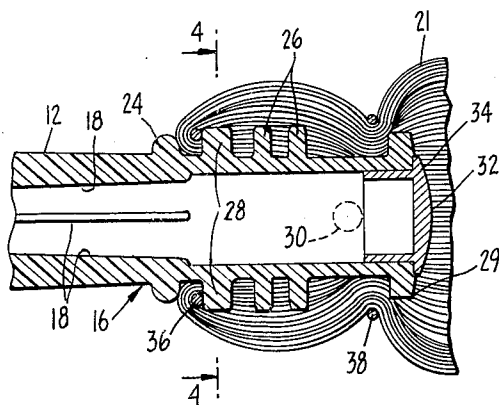

Fig. 3.

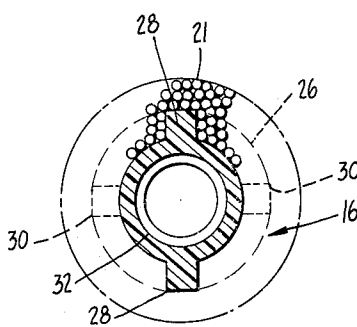

Fig. 4.

INVENTOR
THOMAS C. SHIRLEY
BY
Gardner & Zimmerman
ATTORNEYS

1

2

3,213,475

**CLEANING IMPLEMENT HAVING AN IMPROVED
HAND GRIP PORTION AND MOP HEAD
SECURING MEANS**

Thomas C. Shirley, 3370 Freeman Road,
Walnut Creek, Calif.

Filed Feb. 11, 1963, Ser. No. 257,414
7 Claims. (Cl. 15—229)

The present invention relates generally to cleaning implements, and in particular to an improved, hand mop or brush for use in cleaning toilets, urinals and like objects.

Various shortcomings exist in present day cleaning implements, for example, hand mops or brushes, which are utilized in the cleaning of urinals and toilets. More particularly, wooden handled mops provide a sufficiently rigid construction to permit extensive pressures to be exerted on the mop while scrubbing with same. However, wood deteriorates, develops splinters and is otherwise susceptible to the action of caustic, acidic or similarly corrosive cleaning solutions. Plastic handled mops, on the other hand, are generally resistant to the action of corrosive cleaning agents but are either of solid construction, to provide the necessary rigidity, and are therefore excessively heavy and cumbersome to use for long periods, or are of hollow, lightweight construction and are therefore generally limber and incapable of transmitting the vigorous pressures which are exerted thereon to properly clean an extremely soiled surface.

Furthermore, when extensive pressure is applied to the handle of a conventional mop in the accomplishment of usual scrubbing operations, or the like, the user's hand tends to slide down the handle. Thus where the mop is of the hand mop variety and includes a short handle, the user's hand may slip into the harsh and potentially hazardous cleaning solution used with the mop in producing a cleaning action. Likewise, in the course of scrubbing an object the user will find it necessary to scrub in an upward direction to clean an overhanging surface, which action allows the cleaning solution, unsanitary residue removed in the cleaning operation, etc., to run down the mop handle and into the user's hand. Again, the user is exposed to contact with a generally harsh and potentially hazardous cleaning solution. Thus prior art cleaning implements in general fail to provide a safe and sanitary means for facilitating scrubbing and cleaning of objects such as toilets and urinals with potentially hazardous cleaning agents.

The present invention overcomes the aforementioned shortcomings of prior art mops, brushes, and the like by providing an improved scrubbing implement featuring a light, rigid construction of a unique configuration which facilitates the exertion of increased pressure on the mop head during scrubbing without possibility of the user's hand sliding down the mop handle into the cleaning solution employed therewith, and without possibility of the solution running down the handle and into the user's hand. The improved scrubbing implement construction of the present invention further provides integrally formed, protruding pins in circumferentially disposed relation about the handle head to facilitate securance of the mop head strands thereto in a non-rotatable relation, regardless of the extensive pressures which can be exerted thereon, due to the improved, rigid handle construction.

Therefore it is an object of the present invention to provide an improved cleaning implement for use in cleaning urinals, toilets and similar objects, which is lightweight, rigid, safe and sanitary.

It is another object of the present invention to provide

an improved mop or brush construction, particularly designed to permit the user to exert extensive pressure thereon while using the mop, or brush, without fear of the user's hand sliding down the handle and into the potentially hazardous cleaning solution.

It is still another object of the present invention to provide a mop or brush handle which is capable of withstanding extensive pressure exerted thereon while scrubbing, with a minimum of flexing and with no rotation of the mop head strands about the handle.

It is yet another object of the present invention to provide an improved and sanitary cleaning mop or brush, with a means for preventing the cleaning solution, or other unsanitary liquids, from running down the handle into the user's hand when the mop is held in an upward position.

It is a further object of the present invention to provide an improved cleaning implement handle construction which lends itself readily to mass production with integrally formed pins protruding outward in circumferentially disposed relation about the head portion thereof, to define improved means for positively and non-rotatably securing the mop head thereto.

It is still a further object of the present invention to provide a mop with an improved mop strand securing head portion comprising an integrally formed series of alternately disposed, protruding pins and annular rings which bear into the strands to provide a positive securing action which prevents the strands from twisting during cleaning or wringing.

The invention possesses other objects and features of advantage, some of which, with the foregoing, will be set forth in the following description of the preferred form of the invention which is illustrated in the drawing accompanying and forming part of the specification. It is to be understood, however, that variations in the showing made by the said drawing and description may be adopted within the scope of the invention as set forth in the claims.

FIGURE 1 is an elevation view with portions broken away of one embodiment of the improved mop of the present invention as adapted to hand mop service.

FIGURE 2 is an enlarged cross section view taken along the line 2—2 of FIGURE 1.

FIGURE 3 is an enlarged fragmentary sectional view taken at line 3—3 of FIGURE 1, depicting details of the improved mop head assembly for the positive securance of the strands thereto.

FIGURE 4 is a cross-sectional view taken at line 4—4 of FIGURE 3.

Referring to FIGURES 1 and 2 there is shown a mop 10 in accordance with the present invention which includes a handle 12 having a length determined by the particular use to which the mop is to be put. The mop is herein illustrated and described with particular reference to a short handled hand mop which is particularly suited to the cleaning of toilets, urinals, and the like, however, it will be appreciated that the principles of the invention apply equally as well to mops of somewhat modified form for other purposes, and to brushes and other scrubbing implements.

The handle 12 is preferably formed of a material such as high impact styrene or the like having substantial rigidity while being resistant to caustic, acidic, or otherwise corrosive cleaning agents. The handle includes a grip portion 14 and head portion 16, such portions being coextensively integrally connected. Since the bending moment exerted upon the head portion 16 is less than that exerted along the grip portion (considering the mop head as the fulcrum of a lever), in the interests of saving weight, the head portion 16 is best made of a smaller

3

diameter. Thus the simplest construction is to form the handle 12 as an elongated tapered tubular member. Since a rigid handle is desirable, a plurality of ridges 18 are integrally formed of the handle material, and extend radially inward along a major portion of the handle length. Preferably, the ridges 18 extend inward the greatest amount at approximately the mid-point of the grip portion 14, and taper gradually therefrom to terminate approximately at the head portion 16. In such construction, the wall thickness of the tapered tubular handle is constant, however, as an alternative design the ridges 18 may be eliminated and the inside diameter of the handle held constant along its length. The thickness of the grip portion wall with respect to the head portion is thereby increased in gradually tapering relation to thus increase the rigidity of the grip portion.

Considering now the grip portion 14 in greater detail as to preferred structure, the grip portion is preferably of an external size which is conducive to comfortable gripping by a user with one hand. In addition, a plurality of evenly spaced groups of ribs 15 are advantageously integrally formed along the external surface of the grip portion to provide a roughened gripping surface. Such a roughened surface may, of course, be otherwise provided as by means of a plurality of flutes, a checkered raised surface, or the like, formed in the grip portion. Located a substantial distance from the extreme end of the grip portion 14 is an annular flange or hand guard 20, which protrudes concentrically outward from the handle 12. Thus, the grip portion 14 is defined between the hand guard 20 and the extreme end of the handle 12. More importantly, the outward extending handguard 20 not only provides a stop to prevent the user's hand from sliding down the length of the handle 12, particularly when exerting greater than normal scrubbing pressure, but further provides a barrier to protect the user against the discomfort and possible hazard of having a corrosive cleaning solution from running down the handle 12 into his hand when the mop is held in a position other than level or downward. That is, the hand guard 20 acts as a drip ring from which approaching liquids drip, to thus prevent the passage of such liquids to the grip portion 14 of the handle 12.

Considering now the head portion 16 in greater detail and referring to FIGURES 3 and 4, it is noted that the head portion 16 is arranged in a unique manner to facilitate positive securance of a stranded mop head 21, or the like. The securing means is such that the stranded head will not twist during cleaning operations or during wringing. To this end, the head portion 16 is provided with an annular upper ring 24, two annular center rings 26, and an annular lower ring 29, all of which extend concentrically outward from the head portion 16 at spaced intervals therealong to provide the basis for securing the mop head 21 to the handle 12 in a manner to prevent any axial movement therebetween. In addition, a first pair of pins 28 are integrally formed of the handle material and extend outward from the head portion 16 between the annular upper ring 24 and the annular center rings 26 in diametrically opposed relation. A second pair of diametrically opposed pins 30 are integrally formed of the handle material and extend outward from the head portion 16 between the annular center rings 26 and the lower annular ring 29. The first pair of pins 28 are circumferentially disposed in a right angle relation to the second pair of pins 30. Pins 28 and 30 thus provide means integral with the handle 12, which protrude diametrically outward from the head portion 16 to penetrate into and bind with the thrums of the stranded mop head 21, to thus prevent any rotational motion between the mop head 21 and the handle 12. An end plug 32 with an outwardly extending lip 34 is tightly fitted into the end of head portion 16, or the end is otherwise closed to prevent any liquid from entering the interior of handle 12.

4

It has been found that the diametrically opposed pin configuration described supra provides superior stranded mop head securing means. However, it is to be understood that various other pin and ring combinations are possible. For example, 3 pins may be disposed about the head portion in place of the pairs of pins 28, 30, in other than a diametrically opposed relation. Or the center rings 26 may be eliminated and a series of pins integrally formed along a helical path disposed circumferentially about the head portion 16, spaced between the upper and lower rings 24 and 29 respectively.

In assembly of the mop 10, the thrums or yarns of the mop head 21 are laid evenly longitudinally along the head portion 16 with ends of the thrums positioned approximately even with the pair of pins 30, and with the opposite ends extending along the handle and towards the grip portion 14. A circular lock ring 36, or other clamping means, is bound about the thrums in the region between the upper ring 24 and the first pair of pins 28. The loose ends of thrums are then folded down over the lock ring 36, the pins 28, the annular rings 26 and the end plug 32 to extend beyond the end of the head portion 16. A second circular lock ring 38 is bound about the folded thrums of the head 21 in the region between the second pair of pins 30 and the lower ring 29, to bind the head 21 in its finished form to the head portion 16.

As is evident from the drawing, when the lock rings 36 and 38 are bound about the thrums of the mop head 21, the force created inwardly thereon causes the thrums to arrange themselves tightly around the two pairs of pins 28 and 30. That is, pins 28 and 30 are pressed into and securely engage the mop head 21 not only along one diameter, but also along a second diameter which is circumferentially spaced therefrom by, for example, 90°, to thereby prevent any rotation of the mop head 21 about the head portion 16 regardless of the pressures exerted thereon in the course of energetic scrubbing. The superior securing action afforded by the two pairs of diametrically opposed pins in right angle spacial relation is relatively greater than that provided by conventional single pin construction. Furthermore, since there is no need for an individual and separate step of forcing a pin through the mop head 21 and handle 12 after they are assembled, as is done in prior art mop constructions, the mop of the present invention lends itself to simpler and faster fabrication, with fewer individual parts.

It should be noted that the pair of pins 28 are axially spaced a sufficient distance from the upper annular ring 24 to allow the lock ring 36 to force the thrums enclosed thereby inwardly towards the handle. Likewise, the annular rings 26 are made sufficiently thin, spaced far enough apart, and have a diameter large enough, to cause the thrums passing thereover to bow out away from the handle, and to partially force the thrums into and between the rings 26, thereby causing a binding action thereagainst. Again, the pair of pins 30 are spaced a sufficient axial distance from the lower annular ring 29 to allow the lock ring 38 to force the thrums enclosed by the ring 38 inwardly towards the handle. Rings 26 could be replaced by a single ring of similar thickness which would bite into the thrums of the mop head 21 to provide the same type of binding action thereagainst as afforded by the two rings 26.

Therefore, the improved mop 10 of the present invention provides an extremely lightweight mop having a hand guard 20 to allow the user to exert extensive pressure thereagainst, while simultaneously providing a unique mop head securing construction, which is capable of transmitting such extensive pressure to the mop head with a minimum of flexing and no rotation of the mop head about the handle.

What is claimed is:

1. An improved cleaning implement including a handle and a mop head comprising an elongated hollow tapered member of a material resistant to corrosive solutions,

5

said member having a grip portion disposed at the larger end and a head portion at the smaller end thereof to define said handle, an annular flange integrally formed concentrically about said member at the interior end of said grip portion, stranded mop head securing means including a series of protruding annular rings and pins integrally disposed in predetermined spaced relation about said head portion to bear against and penetrate into a stranded mop head disposed thereabout and positively bind same to said handle.

2. A cleaning implement according to claim 1 wherein said hollow member defining said handle has a plurality of integrally formed ridges protruding inward and along the axial length of the member from within said grip portion to said head portion.

3. A cleaning implement according to claim 1 wherein said hollow tapered member is formed of high impact styrene material.

4. A cleaning implement according to claim 1 wherein said stranded mop head securing means includes an integrally formed upper annular ring, an integrally formed lower annular ring axially spaced a substantial distance from said upper annular ring and about the end of said member, integrally formed annular ring means disposed about said head portion at approximately the mid-point between said upper annular ring and said low annular ring, at least one pin integrally formed to protrude from said head portion between said upper annular ring and said annular ring means, at least one pin integrally formed to protrude from said head portion between said lower annular ring and said annular ring means, first binding means disposed about said mop head in the region between said upper ring and adjacent protruding pin, and second binding means disposed about said mop head in the region between said lower ring and adjacent protruding pin, said binding means forcing said mop head inward towards said handle to bind the mop head against said pins and said annular ring means disposed at said mid-point.

5. An improved mop comprising a hollow tapered handle of a material resistant to corrosive solutions, said handle having a grip portion at the larger end and a head portion at the smaller end thereof, said grip portion having a roughened exterior surface, an annular flange integrally formed concentrically about said handle at the lower end of said grip portion, an upper annular ring integrally formed about said head portion, an integrally formed lower annular ring axially spaced along the handle a substantial distance from said upper ring and at the lower end of the handle, at least two integrally formed intermediate annular rings disposed about said head portion and between said upper and lower annular rings, a first pair of diametrically opposed pins integrally formed to protrude from the head portion between said upper ring and said intermediate rings, and a second pair of diametrically opposed pins integrally formed to protrude from the head portion between said lower ring and said intermediate rings, said first pair of pins being circumferentially spaced 90° from said second pair of pins,

6

a mop head disposed adjacent said head, and binding means disposed about said mop head to force it inwardly against the rings and pins for security to said handle in non-movable relation.

5 6. A scrubbing implement comprising an elongated handle, an annular flange concentrically disposed about said handle at a position spaced from one end thereof to define a grip portion between the flange and first end of the handle, an outwardly projecting ring concentrically disposed at the second end of the handle, a second outwardly projecting ring concentrically disposed about said handle in longitudinally spaced relation to the first ring, at least one first pin projecting radially from said handle at a position adjacently spaced from said first ring, at 10 least one second pin projecting radially from said handle at a position adjacently spaced from said second ring, a mop head having thrums extending longitudinally along said handle adjacent said rings and pins, band means concentrically disposed about said handle and engaging said 15 thrums intermediate said second ring and second pin, said thrums doubled over said band means, and second band means concentrically disposed about said handle and clampingly engaging the doubled over thrums intermediate said first ring and first pin.

20 7. A cleaning element including a handle and which comprises a first ring concentrically outwardly projecting from the head end of said handle, a second ring concentrically outwardly projecting from said handle at a position longitudinally spaced from said first ring, at least one first pin projecting radially from said handle intermediate said rings at a position adjacent the first one thereof, at least one second pin projecting radially from said handle intermediate said rings at a position adjacent the second one thereof and angularly displaced from said 30 first pin, at least one intermediate ring concentrically outwardly projecting from said handle at a position intermediate said first and second pin, and a mop head having thrums extending longitudinally along said handle adjacent said rings and pins, band means concentrically disposed about said handle and engaging said thrums intermediate said second ring and second pin, said thrums doubled over said band means, and second band means concentrically 35 disposed about said handle and clampingly engaging the doubled over thrums intermediate said first ring and 40 first pin.

References Cited by the Examiner

UNITED STATES PATENTS

50	148,278	3/74	Anderson et al. -----	15—189
	908,791	1/09	Mason -----	15—115 X
	1,651,674	12/27	Collins.	
	1,731,339	10/29	Hemple.	
	2,295,914	9/42	Rasic -----	15—229
55	2,825,084	3/58	Sanborn -----	15—210
	2,933,751	4/60	Brownstein -----	15—248 X
	2,998,614	9/61	Winch -----	15—210

CHARLES A. WILLMUTH, *Primary Examiner.*