



- (51) **International Patent Classification:**  
*A61M 25/06* (2006.01) *A61B 1/04* (2006.01)
- (21) **International Application Number:**  
PCT/US2013/032196
- (22) **International Filing Date:**  
15 March 2013 (15.03.2013)
- (25) **Filing Language:** English
- (26) **Publication Language:** English
- (30) **Priority Data:**  
61/697,726 6 September 2012 (06.09.2012) US
- (71) **Applicant:** AVINGER, INC. [US/US]; 400 Chesapeake Drive, Redwood City, CA 94063 (US).
- (72) **Inventors:** SIMPSON, John, B.; 400 Chesapeake Drive, Redwood City, CA 94063 (US). FABRO, Myra, L.; 400 Chesapeake Drive, Redwood City, CA 94063 (US). SUCGANG, Eduardo; 400 Chesapeake Drive, Redwood City, CA 94063 (US). GUPTA, Priyanshu; 400 Chesapeake Drive, Redwood City, CA 94063 (US). KENTAI, Theodore, W.; 400 Chesapeake Drive, Redwood City, CA 94063 (US).
- (74) **Agents:** KELLEHER, Kathleen, R. et al.; Shay Glenn LLP, 2755 Campus Drive, Suite 210, San Mateo, CA 94403 (US).

(81) **Designated States** (unless otherwise indicated, for every kind of national protection available): AE, AG, AL, AM, AO, AT, AU, AZ, BA, BB, BG, BH, BN, BR, BW, BY, BZ, CA, CH, CL, CN, CO, CR, CU, CZ, DE, DK, DM, DO, DZ, EC, EE, EG, ES, FI, GB, GD, GE, GH, GM, GT, HN, HR, HU, ID, IL, IN, IS, JP, KE, KG, KM, KN, KP, KR, KZ, LA, LC, LK, LR, LS, LT, LU, LY, MA, MD, ME, MG, MK, MN, MW, MX, MY, MZ, NA, NG, NI, NO, NZ, OM, PA, PE, PG, PH, PL, PT, QA, RO, RS, RU, RW, SC, SD, SE, SG, SK, SL, SM, ST, SV, SY, TH, TJ, TM, TN, TR, TT, TZ, UA, UG, US, UZ, VC, VN, ZA, ZM, ZW.

(84) **Designated States** (unless otherwise indicated, for every kind of regional protection available): ARIPO (BW, GH, GM, KE, LR, LS, MW, MZ, NA, RW, SD, SL, SZ, TZ, UG, ZM, ZW), Eurasian (AM, AZ, BY, KG, KZ, RU, TJ, TM), European (AL, AT, BE, BG, CH, CY, CZ, DE, DK, EE, ES, FI, FR, GB, GR, HR, HU, IE, IS, IT, LT, LU, LV, MC, MK, MT, NL, NO, PL, PT, RO, RS, SE, SI, SK, SM, TR), OAPI (BF, BJ, CF, CG, CI, CM, GA, GN, GQ, GW, ML, MR, NE, SN, TD, TG).

**Published:**

— with international search report (Art. 21(3))



WO 2014/039096 A1

(54) **Title:** RE-ENTRY STYLET FOR CATHETER

(57) **Abstract:** A stylet for re-entry into a vessel includes an elongate body including a proximal portion, a middle curved portion, a pointed distal end, and a longitudinal axis extending through the proximal portion, the middle curved portion, and the pointed distal end. The proximal portion and the middle curved portion have substantially circular cross-sections. The middle curved portion has a pre-shaped curve along the longitudinal axis configured to match a curve of an occlusion-crossing device. The pointed distal end has an s-curve along the longitudinal axis and a flattened portion along the longitudinal axis, the flattened portion having a substantially oblong cross-section.

**RE-ENTRY STYLET FOR CATHETER****CROSS REFERENCE TO RELATED APPLICATION**

[0001] This application claims the benefit of U.S. Provisional Patent Application No.  
5 61/697,726, filed September 6, 2012, and titled "RE-ENTRY STYLET FOR CATHETER,"  
which is herein incorporated by reference in its entirety.

**INCORPORATION BY REFERENCE**

[0002] All publications and patent applications mentioned in this specification are herein  
10 incorporated by reference in their entireties to the same extent as if each individual publication or  
patent application was specifically and individually indicated to be incorporated by reference.

**BACKGROUND**

[0003] Peripheral artery disease (PAD) affects millions of people in the United States alone.  
15 PAD is a dangerous disease that can have catastrophic consequences when left untreated. PAD  
is the leading cause of amputation in patients over 50 and is responsible for approximately  
160,000 amputations in the United States each year.

[0004] Peripheral artery disease (PAD) is a progressive narrowing of the blood vessels most  
often caused by atherosclerosis, the collection of plaque or a fatty substance along the inner  
20 lining of the artery wall. Over time, this substance hardens and thickens, which may interfere  
with blood circulation to the arms, legs, stomach and kidneys. This narrowing forms an  
occlusion, completely or partially restricting flow through the artery. The most significant of  
these occlusions are called chronic total occlusions (CTO). Blood circulation to the brain and  
heart may be reduced by CTOs, increasing the risk for stroke and heart disease.

25 [0005] Interventional treatments for PAD may include endarterectomy and/or atherectomy.  
Endarterectomy is surgical removal of plaque from the blocked artery to restore or improve  
blood flow. Endovascular therapies such as atherectomy are typically minimally invasive  
techniques that open or widen arteries that have become narrowed or blocked. Other treatments  
may include angioplasty to open the artery. For example, a balloon angioplasty typically  
30 involves insertion of a catheter into a leg or arm artery and is positioned such that the balloon  
resides within the blockage. The balloon, connected to the catheter, is expanded to open the  
artery. Surgeons may then place a wire mesh tube, called a stent, at the area of blockage to keep  
the artery open.

[0006] Such minimally invasive techniques (e.g., atherectomy, angioplasty, etc.) typically  
35 involve the placement of a guidewire through the occlusion. Using the guidewire, one or more

interventional devices may be positioned to remove or displace the occlusion. Unfortunately, placement of the guidewire, while critical for effective treatment, may be difficult. In particular, when placing a guidewire across an occlusion, it may be difficult to pass the guidewire through the occlusion while avoiding damage to the artery. For example, it is often difficult to prevent the guidewire from traveling out of the true lumen and into the subintimal layers, such as the adventitia and surrounding tissues. This can cause damage to the vessel and, once out of the true lumen, it can be difficult to direct the guidewire back into the true lumen, thereby preventing effective treatment of the occlusion.

[0007] Accordingly, a device for effectively crossing an occlusion and/or for reentering the true lumen after entering the subintimal layers would be beneficial.

### SUMMARY OF THE DISCLOSURE

[0008] The present invention relates generally to stylets, and more specifically to stylets used to cross occlusions and/or to re-enter a true lumen of a vessel.

[0009] In general, in one embodiment, a stylet for re-entry into a vessel includes an elongate body including a proximal portion, a middle curved portion, a pointed distal end, and a longitudinal axis extending through the proximal portion, the middle curved portion, and the pointed distal end. The proximal portion and the middle curved portion have substantially circular cross-sections. The middle curved portion has a pre-shaped curve along the longitudinal axis configured to match a curve of an occlusion-crossing device. The pointed distal end has an s-curve along the longitudinal axis and a flattened portion along the longitudinal axis, the flattened portion having a substantially oblong cross-section.

[00010] This and other embodiments can include one or more of the following features. The s-curve can be within the flattened portion. At least one of the distal end or the middle curved portion can include nitinol. The proximal portion can include stainless steel. The pre-shaped curve can form an angle of 130 to 170 degrees. The angle can be approximately 150 degrees. The s-shaped curve can have two curves, the first curve can form a first angle of 120 to 160 degrees and the second curve can form an angle of 120 to 160 degrees. The s-shaped curve can have a first curve and a second curve, the second curve distal to the first curve, and the pre-shaped curve can be aligned in substantially the same direction as the second curve. The pointed distal end can include an anchor. The curved middle portion can be preset to mimic a set bend in an occlusion-crossing catheter.

[00011] In general, in one embodiment, a method of re-entering a true lumen during occlusion-crossing includes orienting a distal end of a catheter having a bend therein towards the true lumen of a vessel; introducing a stylet through a guidewire channel of the catheter until a

curved middle portion of the stylet aligns with the bend in the catheter and a pointed distal end of the stylet extends out of a distal end of the catheter; advancing the stylet such that the pointed distal end pierces through a wall of the vessel; and directing the catheter over the stylet and into the true lumen of the vessel.

5 [00012] This and other embodiments can include one or more of the following features. The method can further include orienting the stylet within the catheter such that the pointed distal end of the stylet curves sharply towards the vessel wall before advancing the stylet. The method can further include reorienting the catheter within the true lumen after directing the catheter of the stylet. Reorienting the catheter can include reorienting without puncturing an opposite vessel  
10 wall. The method can further include determining an orientation of the stylet based upon an alignment of the curved middle portion with the bend in the catheter. The catheter can further include a proximal portion, the proximal portion and the curved middle portions can have substantially circular cross-sections, and the pointed distal end can have a flatted portion and can have a substantially oblong cross-section. The method can further include using image guidance  
15 to orient the catheter.

[00013] In general, in one embodiment, an assembly for re-entry into a vessel includes a catheter and a stylet. The catheter includes a pre-set curve. The stylet includes an elongate body having a proximal portion, a middle flexible portion, and a distal stiff portion. When the stylet is inserted into the catheter, the flexible portion is configured to conform to the pre-set curve and  
20 the distal stiff portion is configured to at least partially straighten the pre-set curve. The flexible portion has a length such that the flexible portion can align with the pre-set curve both while the distal stiff portion remains inside the catheter and while the distal stiff portion extends distally from a distal end of the catheter.

[00014] This and other embodiments can include one or more of the following features. The  
25 distal stiff portion can include a sharp pointed end. The middle flexible portion can include a flexible coil. The proximal portion can be stiffer than the middle flexible portion.

[00015] In general, in one embodiment, an assembly for re-entry stylet for re-entry into a vessel includes a catheter and a stylet. The catheter includes a pre-set curve. The stylet includes a flexible elongate body having a pointed distal end. The stylet further includes a stiff tube  
30 concentric with the flexible elongate body, the flexible elongate body axially movable relative to the stiff tube. When the stylet is inserted into the catheter, the flexible portion is configured to conform to the pre-set curve, and the flexible elongate body is configured to at least partially straighten the pre-set curve.

[00016] This and other embodiments can include one or more of the following features. The flexible elongate body can include a pre-set curve configured to match the pre-set curve of the catheter. The flexible elongate body can include a shape memory material.

5 [00017] In general, in one embodiment, a stylet for re-entry into a vessel includes an elongate body having a pointed distal tip. The stylet includes a coiled member attached to the pointed distal tip. The coiled member includes a relaxed configuration where the coiled member extends over the pointed distal portion and a compressed configuration wherein the coiled member is compressed to expose at least a portion of the pointed distal tip.

10 [00018] Methods of using the stylets to reenter a lumen, such as for occlusion crossing, are also described herein.

### BRIEF DESCRIPTION OF THE DRAWINGS

[00019] The novel features of the invention are set forth with particularity in the claims that follow. A better understanding of the features and advantages of the present invention will be obtained by reference to the following detailed description that sets forth illustrative embodiments, in which the principles of the invention are utilized, and the accompanying drawings of which:

[00020] FIG. 1A is a side view of the distal end of an exemplary directional re-entry stylet.

20 [00021] FIG. 1B is a close-up of the distal tip of the directional re-entry stylet of FIG. 1B.

[00022] FIG. 2A is a schematic of a directional re-entry stylet such as the one shown in FIG. 1A.

[00023] FIG. 2B is a close-up of the distal tip shown in FIG. 2A.

[00024] FIG. 2C is a close-up of the junction shown in FIG. 2A.

25 [00025] FIG. 3A is a schematic of an exemplary aligning re-entry stylet having a central flexible section.

[00026] FIG. 3B is a close-up of the flexible section of the aligning re-entry stylet of FIG. 3A.

[00027] FIGS. 4A-4C show the re-entry stylet of FIG. 3A in an exemplary CTO crossing device with a pre-set curve. FIG. 4A shows the re-entry stylet is aligned within the device such that the angle of the pre-set curve is not changed by the stylet. FIG. 4B shows the exemplary CTO crossing device straightened using the re-entry stylet. FIG. 4C shows the exemplary CTO crossing device with the re-entry stylet extending from the distal end.

[00028] FIGS. 5A-5C show an exemplary process for producing the stylet of FIG. 3A.

35 [00029] FIG. 6 shows an exemplary bilayer re-entry stylet having a stiff outer tube and a flexible inner elongate body.

[00030] FIGS. 7A-7D shows the bilayer re-entry stylet of FIG. 6 in an exemplary CTO crossing device with a pre-set curve. FIG. 7A shows the stylet placed such that both the outer tube and the inner elongate body are proximal of the pre-set curve. FIG. 7B shows the outer tube moved distal to the pre-set curve such that the pre-set curve is straightened. FIG. 7C shows the outer tube positioned proximal to the pre-set curve and the inner elongate body extended out the distal end of the catheter. FIG. 7D shows the outer tube moved distal to the pre-set curve such that the pre-set curve is straightened and the inner elongate body extended out the distal end of the catheter.

[00031] FIG. 8 shows an exemplary manipulator for steering a re-entry stylet.

10 [00032] FIG. 9A shows an exemplary stylet tip having a hook anchoring mechanism. FIG. 9B shows an exemplary stylet tip having a drill anchoring mechanism.

[00033] FIG. 10A shows a spring-loaded stylet in passive mode. FIG. 10B shows a spring-loaded stylet in active mode.

15 [00034] FIG. 11A shows an exemplary occluded vessel. FIG. 11B shows an occlusion-crossing catheter that has extended into the subintimal layers of the occluded vessel of FIG. 11A. FIG. 11C shows the occlusion crossing catheter of FIG. 11B trapped in the subintimal layer.

[00035] FIGS. 12A-12D show use of a stylet similar to the stylet of FIG. 1A to guide a catheter from the subintimal layer back into the true lumen. FIG. 12A shows the stylet pointing out of the catheter. FIG. 12B shows the stylet piercing through the vessel wall. FIG. 12C shows the catheter reentering the true lumen over the stylet. FIG. 12D shows the catheter reoriented within the true lumen.

25 [00036] FIGS. 13A-13C show use of a stylet similar to the stylet of FIG. 4A to guide a catheter from the subintimal layer back into the true lumen. FIG. 13A shows the stylet piercing the vessel wall. FIG. 13B shows the catheter reentering the true lumen over the stylet. FIG. 13C shows the catheter reoriented within the true lumen.

30 [00037] FIGS. 14A-14D shows use of a stylet similar to the stylet of FIG. 6 to guide a catheter from the subintimal layer back into the true lumen. FIG. 14A shows the stylet within the catheter. FIG. 14B shows the stylet piercing the wall. FIG. 14C shows the catheter reentering the true lumen over the stylet. FIG. 14D shows the stylet straightening the catheter to reorient it within the true lumen.

### DETAILED DESCRIPTION

35 [00038] Referring to FIG. 11A, an occluded vessel 1000 includes a lumen 1022 (or “true lumen”) with an occlusion 1021 and an arterial wall 1020. The arterial wall 1020 can include an innermost intimal layer 1026, which can include the endothelium, the subendothelial layer, and

the internal elastic lamina. A relatively soft medial layer 1028 (also called the “subintimal space”) surrounds the intimal layer 1026, which is then surrounded by an advential layer 1024. The proximal and distal caps 1042, 1044 of the occlusion are generally very hard relative to the rest of the occlusion. As a result, when a guidewire or occlusion-crossing device hits one of the caps 1042, 1044, it can often end up deflecting off of the cap 1042, 1044 and extending through the intimal layer 1026 and into the relatively soft medial layer 1028. For example, referring to FIG. 11B, an occlusion-crossing device 1100 has extended into the subintimal space within the medial layer 1028, which can define a “false lumen.” As shown in FIG. 11C, the occlusion-crossing device 1100 can then get trapped in the subintimal space outside the true lumen 1022.

5  
10 **[00039]** Stylets are described herein that can be used to assist in occlusion-crossing within a blocked vessel. For example, in some embodiments, the stylets described herein can redirect occlusion-crossing devices back into the true lumen of a vessel. In addition or alternatively, the stylets described herein can straighten and/or deflect an occlusion-crossing device to orient the device as needed.

15 **[00040]** In general, any of the stylets described herein can have a deflection region at the distal end thereof to provide directionality and steerability of the catheter. The deflection region can, for example, be imparted by a pre-shaped curve that matches an inner lumen of a catheter. The deflection region can also be imparted by an s-shaped curve at the distal tip of the stylet that helps orient and direct the stylet back into the true lumen of a vessel. In some embodiments, the deflection region can have a flattened profile to provide stability during piercing of the vessel wall into the true lumen.

20 **[00041]** Any of the stylets described herein can further be designed to include both flexible and stiff portions along the longitudinal axis to aid both in conforming the stylet to a catheter in which it is inserted and in providing the necessary stiffness to puncture a vessel wall. The stylets can include a proximal portion, a middle flexible portion, and a distal stiff portion. The middle flexible portion can be flexible enough to conform to a curve of a catheter in which the stylet is inserted while the distal stiff section can be stiff enough to provide a piercing force to guide the stylet into a true lumen of a vessel.

25 **[00042]** The stylets described herein can include an inner flexible body and an outer stiff tube. The flexible body and outer stiff tube can be moved axially relative to one another to provide the desired stiffness or flexibility for the stylet, e.g., to provide flexibility to extend around a pre-set curve in a catheter or to provide stiffness to straighten the pre-set curve. In other embodiments, the inner body can be stiff while the outer tube can be flexible.

[00043] Furthermore, the stylets described herein can include a coiled member attached to the distal tip to provide protection for the tip when in the extended configuration and allow for exposure of the tip when compressed.

5 [00044] Referring to FIGS. 1A through 2C, an exemplary directional re-entry stylet 100 includes a proximal portion 101, a middle curved portion 102, and a distal pointed end 103.

[00045] The proximal portion 101 can be a wire, such as a stainless steel wire. The wire can be chosen to have a stiffness that corresponds to the required amount of pushability and column support needed for the particular wire diameter used. The proximal portion 101 can further have a substantially round cross-section. The proximal portion 101 can be approximately .010 to .035  
10 inches in diameter, such as approximately .015 inches in diameter.

[00046] The curved middle portion 102 can have a pre-set curve 105 that is flexible enough to follow the contours of lumen of a catheter but stiff enough to orient its curved shape to align with a bent section of an the catheter. For example, referring to FIG. 2B, the pre-set curve 105 can form an angle  $\alpha$  of between 120 degrees and 180 degrees, such as between about 130 degrees  
15 and 170 degrees, for example approximately 150 degrees. The pre-set curve can advantageously ensure that the stylet 100 aligns properly with the catheter in which it is inserted, thereby allowing the catheter to maintain its curved form and ensuring proper steering of the catheter.

[00047] Further, in other embodiments, the pre-set curve 105 can be stiff enough to change the deflection region of the catheter in which it is inserted. Thus, for example, the pre-set curve  
20 105 could force the catheter into a set angle of between 120 degrees and 180 degrees, such as between about 130 degrees and 170 degrees, such as 150 degrees. In some embodiments, rather than having a pre-set curve, the curved middle portion 102 can have a flexible portion, such as a necked section or a coiled section, to allow the middle portion 102 to flexibly conform to the shape of a catheter in which it is inserted.

25 [00048] The curved middle portion 102 can be formed of a wire, such as a nitinol wire. The curved middle portion can further have a substantially round cross-section. The curved middle portion 102 can have a diameter of approximately 0.008 inches to 0.015 inches, such as approximately .012 inches in diameter. In some embodiments, the middle portion 102 is formed separately from the proximal portion 101 and connected through a junction 106, such as a  
30 hypotube joint (see FIG. 2C) or a laser welded sleeve. In other embodiments, the middle portion 102 and proximal portion 101 can be formed of a single piece of material, such as a single wire.

[00049] The pointed distal end 103 can include an s-shaped curve 107 (see FIGS. 1B and 2B), i.e., include two opposing curves 109 and 111 along the longitudinal axis. Referring to FIG. 2B, the proximal-most curve 109 of the s-shaped curve 107 can have an angle  $\beta$  of between  
35 approximately 90° to 180°, such as between about 120 ° to 160 °, such as 150°, while the distal-



most curve 111 of the s-shaped curved 107 can have an angle  $\theta$  of between approximately  $90^\circ$  to  $180^\circ$ , such as  $120^\circ$  to  $160^\circ$ , such as  $150^\circ$ . The s-curve 107 can be oriented such that the distal end 103 points in approximately the same direction as the end of the catheter, as set by the pre-set curve 105. That is, referring to FIG. 2B, the angle  $\alpha$  can be oriented in approximately the same direction as the angle  $\theta$  while the angle  $\beta$  can be aligned in substantially the opposite direction. Angles  $\beta$  and  $\theta$  can be approximately equal to one another. Further, having the distal end 103 point in the same direction as the distal end of the catheter (set by the jog in the catheter) advantageously provides more of an angle for re-entry into a true lumen. Finally, the alignment of the angle  $\alpha$  with the angle  $\theta$  also advantageously provides an indication as to the orientation of the stylet.

[00050] The distal tip 115 (between the distal-most point and the distal curve 111) can be less than about 3mm, such as between about 1-2mm. Further, the stylet 100 itself can be about 150cm-300cm in length, such as 175cm to 200cm, such as approximately 180cm in length. Thus, the distal tip 115 can comprises less than 1%, such as less than 0.5% of the total length of the stylet 100. The short length of the distal tip 115 relative to the length of the entire stylet 100 advantageously provides that the stylet will advance only partially through the vessel wall and back into the true lumen during reentry (i.e., to avoid puncturing the opposite wall of the vessel).

[00051] In other embodiments, rather than having an s-shaped curve 107, the pointed distal end 103 can include a J-shaped curve, i.e. a hook, that can be used to force the stylet 100 (and thus the catheter in which it is inserted) back towards a true lumen.

[00052] The pointed distal end 103 can further included a flattened portion, i.e., a portion in which the otherwise round cross-section has been flattened to include two substantially parallel and flat surfaces, e.g., such that a cross-section of the flattened portion is substantially oblong. As shown in FIG. 1B, the s-curve 107 can be located within the flattened portion such that the shape of the "s" is formed on the flattened surface. This flattened portion can advantageously help to hold the pre-set curve as it is forced against tissue. The flattened portion can also advantageously provide rigidity as the tip of the stylet is forced into tissue.

[00053] Further, the pointed distal end 103 can be tapered from the proximal end to the distal end. For example, the distal end can be .012 inches in diameter and can taper down to a tip 115 of approximately .005 inches in diameter. The tip 115 of the pointed distal end 103 can be sharp, i.e., can be configured to penetrate tissue, such as subintimal layers of a blood vessel. The taper can advantageously provide smooth dilation or entry into a vessel wall or occlusion.

[00054] Referring to FIGS. 12A-12D, in one embodiment, a stylet 100 can be used as a re-entry tool for an occlusion-crossing catheter 1100 that has exited the true lumen 1022 and entered the subintimal layer (e.g., medial layer 1028). The stylet 100 can be placed through a

guidewire channel of a catheter 1100. The catheter 1100 can have a fixed bend 1114, which can be rotated to point towards the true lumen 1022. As shown in FIG. 12A, the stylet 100 can be threaded through the catheter 1100 such that the curved middle portion 102 aligns with the bend 1114 in the catheter 1100 and such that the tip 115 points out the distal end of the catheter.

5 Because the angle of the curved middle portion 102 is pointed in the same direction as the distal-most curve of the s-shaped curve, and because the fixed bend 1114 has been oriented towards the true lumen 1022, the distal tip 115 will also point towards the true lumen 1022. Further, referring to FIG. 12B, because the curved middle portion 102 has a pre-set curve, the curve will hold the stylet's orientation as it is advanced. Thus, as the stylet is advanced, the distal tip 115  
10 will curve even more sharply towards the true lumen 1022 and pierce back through the tissue of the vessel wall 1020 at a steep angle (e.g. at an angle of between approximately 60 and 90 degrees relative to the wall). Referring to FIG. 12C, the catheter 1100 can then be advanced over the stylet 100 back into the true lumen 1022. As shown in FIG. 12D, to reorient the catheter 1100 towards down the axis of the lumen 1022, the catheter can be rotated approximately 180  
15 degrees to point the fixed bend 1114 down the lumen 1022. In some embodiments, this process can be used to pass entirely by an occlusion (as shown in FIGS. 12A-12D). In other embodiments, the stylet 100 can direct the catheter 1100 back into the occlusion at a point between the proximal 1042 and distal 1044 caps of the occlusion 1021, and then the catheter 1100 can be used to finish crossing through the lesion, such as will a rotating drill feature on the  
20 distal end of the catheter.

[00055] Referring to FIGS. 3A-3B, an aligning re-entry stylet 200 includes a proximal portion 201, a middle flexible portion 202, and a distal stiff portion 203.

[00056] The proximal portion 201 can be a wire, such as a stainless steel wire. The wire can be stiff enough to provide pushability through a catheter. The proximal portion 201 can be  
25 approximately .010 to .038 inches in diameter, such as approximately .015 inches in diameter.

[00057] The middle flexible portion 202 is configured to be flexible so as to conform to the shape of a catheter in which it is inserted. In one embodiment, the flexible portion 202 is a coil, such as a coil of wire. The coil can have an outer diameter of .010 to .038 inches, such as approximately .014 inches and an inner diameter of .005 to .010 inches, such as approximately  
30 .008 inches. The coil can be made, for example, of stainless steel. The wire forming the coil can have a diameter of .001 to .005 inches, such as approximately .003 inches. In another embodiment, the middle flexible portion 202 could be a necked portion in a wire. In another embodiment, the middle flexible portion 202 can be a separate flexible material, such as a plastic. In another embodiment, the middle flexible portion 202 can be a hypotube that has been  
35 cut, such as laser cut, into a flexible spiral or plurality of rings along a spine.

[00058] The proximal stiff portion 203 can be stiff enough to straighten a prebent catheter in which it is inserted. For example, the proximal stiff portion can be made of a stainless steel wire. The wire can have a diameter, for example, of .010 to .038 inches, such as approximately .015 inches. The distal portion 203 can further include a sharp tip 212, such as a needle-like or pointed end. In some embodiments, the sharp tip 212 can be angled to assist in re-entry.

[00059] The flexible portion 202 can have a length such that the flexible portion can align with a pre-set curve 414 in a catheter 400 in which it is inserted both while the distal stiff portion 203 remains inside the catheter 400 (FIG. 4A) and while the distal stiff portion 203 extends distally from the distal end of the catheter 400 (FIG. 4C).

[00060] In use, referring to FIGS. 4A-4C, the stylet 200 can be inserted into a catheter, such as a catheter 400 having a pre-bent curve 414. As shown in FIG. 4A, the stylet 200 can be inserted such that the flexible portion 202 aligns with the pre-bent curve 414 while the distal portion 203 remains inside the catheter. This alignment can advantageously provide little interference with the catheter as the catheter is used under normal conditions.

[00061] The stylet 200 can also be inserted such that the distal stiff portion 203 aligns with the pre-bent curve 414, thereby straightening the curve, as shown in FIG. 4B. This alignment can advantageously make directly entry into an occlusion easier, i.e., placing force on a straightened catheter, from within the true lumen, can provide a straight trajectory into the occlusion.

[00062] Finally, as shown in FIG. 4C, the stylet 200 can be inserted such that the flexible portion 202 aligns with the pre-bent curve 414 while the distal portion 203 extends out of the distal end of the catheter 400. This alignment can advantageously assist in re-entry from a false lumen to a true lumen, i.e., the curve of the catheter 400 can be turned towards the true lumen, and the distal end 203 of the stylet 200 can be used to pierce the vessel and guide the catheter 400 back into the true lumen. For example, FIGS. 13A-13C show a stylet 200 used as a re-entry tool for an occlusion-crossing catheter 1100 that has exited the true lumen 1022 and entered the subintimal layer (e.g., medial layer 1028). The stylet 200 can be placed through a guidewire channel of the catheter 1100. The catheter 1100 can have a fixed bend 1114, which can be rotated to point towards the true lumen 1022. As shown in FIG. 13A, the stylet 200 can be threaded through the catheter 1100 such that the flexible portion 202 aligns with the fixed bend 1114 while the distal portion extends out of the distal end of the catheter 1100. Because the fixed bend 1114 has been oriented towards true lumen 1022, the sharp distal portion 203 will also point towards the true lumen 1022, making it easy to pierce the wall 1020. Referring to FIG. 13B, the catheter 1100 can then be advanced over the stylet 200 back into the true lumen 1022. As shown in FIG. 12C, to reorient the catheter 1100 towards down the axis of the lumen 1022, the catheter can be rotated approximately 180 degrees to point the fixed bend 1114 down

the lumen 1022. In some embodiments, this process can be used to pass entirely by an occlusion (as shown in FIGS. 13A-13C). In other embodiments, the stylet 200 can direct the catheter 1100 back into the occlusion at a point between the proximal 1042 and distal 1044 caps, and then the catheter 1100 can be used to finish crossing through the lesion, such as with drilling features on the catheter 1100.

5 [00063] Referring to FIGS. 5A-5C, a stylet 200 can be made, for example, by grinding two mandrels to a taper 510a,b (the mandrels will form the proximal and distal ends, respectively), and then placing the tapers 510a,b inside a coil 202 and connecting the coil 202 to each taper 510a,b, as shown in FIG. 5C.

10 [00064] Referring to FIG. 6, a stylet 300 can include an outer tube 310 and an inner elongate body 312 axially movable relative to the outer tube 310. The outer tube 310 can be stiff relative to the inner elongate body 312. The inner elongate body 312 can have a pointed or sharp distal end 303 similar to the distal end of the stylets 100, 200. The inner elongate body 312 and/or the outer tube 310 can be made of a metal, such as stainless steel or nitinol.

15 [00065] Further, referring to FIGS. 7A-7B, the stylet 300 can be configured to be placed within a lumen of a catheter, such as a catheter 500 having a pre-set curve 514. The outer tube 310 can be stiff relative to the pre-set curve 514 while the inner elongate body 312 can be flexible relative to the pre-set curve 514. As a result, the outer tube 310 can be used to straighten the pre-set curve 514 while the inner elongate body 312 can conform to the pre-set curve 514.

20 [00066] Thus, referring to FIG. 7A, the stylet 300 can be placed such that the entire stylet 300 is proximal to the pre-set curve 514. As shown in FIG. 7B, if the outer tube 310 is advanced distal to the pre-set curve 514, then the pre-set curve 514 of the catheter 500 will substantially straighten out. Such straightening can be advantageous, for example, if the catheter 500 is being used to cross a CTO from within the true lumen, as force can be applied on the CTO from substantially perpendicular to the CTO. Referring to FIG. 7D, the inner elongate body 312 can also be extended out of the distal end of the catheter while the catheter is in a straightened position to assist with crossing the CTO (e.g. such that the pointed distal end 303 can cut through the occlusion or pierce the proximal or distal cap). On the other hand, as shown in FIG. 7C, if only the inner elongate body 312 is advanced distal to the pre-set curve 514, then the pre-set curve 514 can maintain its shape while the pointed distal end 303 can be advanced out of the catheter 500. This configuration can be advantageous, for example, for re-entry from a false lumen to a true lumen, i.e. the curve 514 of the catheter 514 can be turned towards the true lumen, and the pointed distal end 303 of the inner elongate body 312 can be used to pierce the vessel and guide the catheter 500 back into the true lumen.

[00067] FIGS. 14A-14D show a stylet 300 used as a re-entry tool for an occlusion-crossing catheter 1100 that has exited the true lumen 1022 and entered the subintimal layer (e.g., medial layer 1028). As shown in FIG. 14A, the stylet 300 can be placed through a guidewire channel of the catheter 1100. The catheter 1100 can have a fixed bend 1114, which can be rotated to point  
5 towards the true lumen 1022. Referring to FIG. 14B, the inner elongate body 312 can then be extended towards the true lumen 1022. Because the fixed bend 1114 has been oriented towards the true lumen 1022, the pointed distal end 303 will also point towards the true lumen 1022, thereby allowing it to pierce the vessel wall 1020 as it is extended. Referring to FIG. 14C, the catheter 1100 can then be advanced over the stylet 300 back into the true lumen 1022. As shown  
10 in FIG. 12D, the outer tube 310 can then be extended within the catheter 1100 such that it straightens the fixed bend 1114. Such straightening of the fixed bend 1114 will point the catheter 1100 more directly down the true lumen 1022. In some embodiments, this process can be used to pass entirely by an occlusion (as shown in FIGS. 14A-14D). In other embodiments, the stylet 300 can direct the catheter 1100 back into the occlusion at a point between the  
15 proximal 1012 and distal 1044 caps, and then the catheter 1100 can be used to finish crossing through the lesion.

[00068] In some embodiments, the inner elongate body 312 can have a pre-set curve that substantially matches the pre-set curve 514 of the catheter 500. For example, the inner elongate body 312 can be made of a shape memory material, such as nitinol, to set the curve. Having this  
20 matched curve can advantageously help with re-entry into the true lumen. That is, if the user steers the directionality of the catheter 500 towards the true lumen, then when the curved inner elongate body 312 exits, it will curve and be directed towards the true lumen even more than the catheter itself, helping to avoid deflection off of the vessel wall.

[00069] In general, a sharp distal tip of any of the stylets described herein may be protected or  
25 covered until deployment into tissue. For example, a spring loaded sheath or housing can be pushed distally along the long axis of the tip to expose the sharp tip. For example, as shown in FIGS. 10A and 10B, a stylet 900 can include a spring-loaded mechanism 902 on the distal end of a stylet body 910. Thus, a coiled member 904 can be configured to extend over the tip 906 of the stylet, which can be sharp and/or tapered. Referring to FIG. 10A, in the passive mode, i.e.  
30 before contacting tissue, the coiled member 904 can cover the tapered or sharp end of the stylet so that the end is atraumatic in non-targeted areas. Once the location of re-entry is reached, the tip 906 can be advanced into the tissue, thus activating the spring mechanism (shown in FIG. 10B) as the coil compresses and exposes the penetrating tip 906.

[00070] The length of exposed tip 906 can be controlled by placing the coiled member 904 in  
35 the desired location along the stylet body 910. Accordingly, the initial length of the tip 906 that

is exposed through the vessel wall or occlusion can be limited by the coiled member 904, advantageously avoiding over-puncturing and possibly hitting the opposing vessel wall. Further, the pitch of the coiled member 904 can be chosen based upon the desired spring force required to penetrate or puncture the tissue, such as based upon the type or thickness of the tissue. Once the tip has been pushed fully through, the coiled member 904 can act as a temporary stop, providing tactile feedback for the user and allowing the user to adjust the angle or orientation of the stylet tip. Additional force can then be placed on the stylet 900 to push the coiled member 904 through. Once the proximal end of the coiled member 904 is fully advanced through the tissue, the coiled member can relax, allowing the stylet 900 to be in passive mode again as it traverses through the vessel.

[00071] Although a coiled member 904 is shown in FIGS. 10A and 10B, other spring loaded mechanisms 902 are possible. Advantageously, spring loaded mechanisms 902 on the stylet can help control depth of penetration and also provide a safer method of controlling re-entry. The spring-loaded mechanism 902 can be used with a traditional stylet or with any of the stylets described herein.

[00072] Referring to FIG. 8, a handle 800 can be used to steer any of the stylets described herein. The handle 800 can include a locking mechanism to lock it onto the proximal end of the device, such as a luer fitting. In one embodiment, the handle 800 can have predefined positions that align the stylet appropriately with the catheter. For example, if the handle 800 is used with the stylet 200, the handle can lock the stylet 200 in a first position where the stylet 300 is proximal of the bend in the catheter, thereby allowing the main body of the catheter to have extra support. The handle can also lock the stylet 200 in a second position where the distal stiff section of the stylet 200 is in the prebent section of the catheter, thereby straightening the catheter. Finally, the handle 800 can lock the stylet 200 in a third position where the distal part of the stylet 200 sticks out of the distal tip of the catheter, thereby enabling re-entry into the true lumen. The handle 800 can include similar predefined positions when used with the other stylets described in here.

[00073] Any of the embodiments of stylets herein can include an anchoring mechanism on or near the distal tip. For example, the distal end can include a hook 991 as shown in FIG. 9A or a drill tip 993 as shown in FIG. 9B. The anchoring mechanism can anchor the stylet in a particular location where re-entry is desired, i.e., can prevent proximal movement, and then can be dislodged as the stylet is advanced distally past the location.

[00074] Any of the stylets described herein can include a marker, such as a radiopaque marker, to help identify the location of the stylet in situ with imaging. For example, referring to the stylet 100 of FIGS. 1A-2C, the connector 106 between the proximal portion 101 and the

middle portion 102 can form the radiopaque marker. In some embodiments, a radiopaque coating, such as platinum, can be applied to portions of the stylet 100.

[00075] Any of the stylets described herein can include a torquer configured to be tightened onto the stylet for rotational control. In some embodiments, the torquer can be aligned with a particular angle in the stylet. For example, the torquer can align with one or more of the angles of the s-curve 107 of the stylet 100.

[00076] Any of the stylets described herein can be sized and configured to fit within a guidewire channel of a catheter, such as through a guidewire channel of an occlusion-crossing device. Such exemplary occlusion-crossing devices are described in co-pending Patent Applications: U.S. Patent Application No. 12/829,267, titled "CATHETER- BASED OFF-AXIS OPTICAL COHERENCE TOMOGRAPHY IMAGING SYSTEM," filed 7/1/2010, Publication No. US-2010-0021926-A1; U.S. Patent Application No. 13/433,049, titled "OCCLUSION-CROSSING DEVICES, IMAGING, AND ATHERECTOMY DEVICES," filed 3/28/2012, Publication No. US-2012-0253186-A1; International Patent Application titled "OCCLUSION-CROSSING DEVICES," filed herewith; and International Patent Application titled "CHRONIC TOTAL OCCLUSION CROSSING DEVICES WITH IMAGING," filed herewith, all of which are incorporated by reference in their entireties.

[00077] Further, any of the stylets and/or catheters described herein can be oriented, directed, or steered using image guidance, such as optical coherence tomography, ultrasound, radiofrequency imaging, or fluoroscopy.

[00078] Additional details pertinent to the present invention, including materials and manufacturing techniques, may be employed as within the level of those with skill in the relevant art. The same may hold true with respect to method-based aspects of the invention in terms of additional acts commonly or logically employed. Also, it is contemplated that any optional feature of the inventive variations described may be set forth and claimed independently, or in combination with any one or more of the features described herein. Likewise, reference to a singular item, includes the possibility that there are a plurality of the same items present. More specifically, as used herein and in the appended claims, the singular forms "a," "and," "said," and "the" include plural referents unless the context clearly dictates otherwise. It is further noted that the claims may be drafted to exclude any optional element. As such, this statement is intended to serve as antecedent basis for use of such exclusive terminology as "solely," "only" and the like in connection with the recitation of claim elements, or use of a "negative" limitation. Unless defined otherwise herein, all technical and scientific terms used herein have the same meaning as commonly understood by one of ordinary skill in the art to which this invention belongs. The

breadth of the present invention is not to be limited by the subject specification, but rather only by the plain meaning of the claim terms employed.

**[00079]** When a feature or element is herein referred to as being "on" another feature or element, it can be directly on the other feature or element or intervening features and/or elements may also be present. In contrast, when a feature or element is referred to as being "directly on" another feature or element, there are no intervening features or elements present. It will also be understood that, when a feature or element is referred to as being "connected", "attached" or "coupled" to another feature or element, it can be directly connected, attached or coupled to the other feature or element or intervening features or elements may be present. In contrast, when a feature or element is referred to as being "directly connected", "directly attached" or "directly coupled" to another feature or element, there are no intervening features or elements present. Although described or shown with respect to one embodiment, the features and elements so described or shown can apply to other embodiments. It will also be appreciated by those of skill in the art that references to a structure or feature that is disposed "adjacent" another feature may have portions that overlap or underlie the adjacent feature.

**[00080]** Terminology used herein is for the purpose of describing particular embodiments only and is not intended to be limiting of the invention. For example, as used herein, the singular forms "a", "an" and "the" are intended to include the plural forms as well, unless the context clearly indicates otherwise. It will be further understood that the terms "comprises" and/or "comprising," when used in this specification, specify the presence of stated features, steps, operations, elements, and/or components, but do not preclude the presence or addition of one or more other features, steps, operations, elements, components, and/or groups thereof. As used herein, the term "and/or" includes any and all combinations of one or more of the associated listed items and may be abbreviated as "/".

**[00081]** Spatially relative terms, such as "under", "below", "lower", "over", "upper" and the like, may be used herein for ease of description to describe one element or feature's relationship to another element(s) or feature(s) as illustrated in the figures. It will be understood that the spatially relative terms are intended to encompass different orientations of the device in use or operation in addition to the orientation depicted in the figures. For example, if a device in the figures is inverted, elements described as "under" or "beneath" other elements or features would then be oriented "over" the other elements or features. Thus, the exemplary term "under" can encompass both an orientation of over and under. The device may be otherwise oriented (rotated 90 degrees or at other orientations) and the spatially relative descriptors used herein interpreted accordingly. Similarly, the terms "upwardly", "downwardly", "vertical", "horizontal" and the like are used herein for the purpose of explanation only unless specifically indicated otherwise.



[00082] Although the terms “first” and “second” may be used herein to describe various features/elements, these features/elements should not be limited by these terms, unless the context indicates otherwise. These terms may be used to distinguish one feature/element from another feature/element. Thus, a first feature/element discussed below could be termed a second feature/element, and similarly, a second feature/element discussed below could be termed a first feature/element without departing from the teachings of the present invention.

[00083] As used herein in the specification and claims, including as used in the examples and unless otherwise expressly specified, all numbers may be read as if prefaced by the word "about" or “approximately,” even if the term does not expressly appear. The phrase “about” or “approximately” may be used when describing magnitude and/or position to indicate that the value and/or position described is within a reasonable expected range of values and/or positions. For example, a numeric value may have a value that is +/- 0.1% of the stated value (or range of values), +/- 1% of the stated value (or range of values), +/- 2% of the stated value (or range of values), +/- 5% of the stated value (or range of values), +/- 10% of the stated value (or range of values), etc. Any numerical range recited herein is intended to include all sub-ranges subsumed therein.

## CLAIMS

What is claimed is:

1. A stylet for re-entry into a vessel comprising:  
5 an elongate body having a proximal portion, a middle curved portion, a pointed distal end, and a longitudinal axis extending through the proximal portion, the middle curved portion, and the pointed distal end;  
wherein the proximal portion and the middle curved portion have substantially circular cross-sections, and wherein the middle curved portion has a pre-shaped curve along the  
10 longitudinal axis configured to match a curve of an occlusion-crossing device; and  
wherein the pointed distal end has an s-curve along the longitudinal axis and a flattened portion along the longitudinal axis, the flattened portion having a substantially oblong cross-section.
- 15 2. The stylet of claim 1, wherein the s-curve is within the flattened portion.
3. The stylet of claim 1, wherein at least one of the distal end or the middle curved portion comprises nitinol.
- 20 4. The stylet of claim 1, wherein the proximal portion comprises stainless steel.
5. The stylet of claim 1, wherein the pre-shaped curve forms an angle of 130 to 170 degrees.
6. The stylet of claim 5, wherein the angle is approximately 150 degrees.  
25
7. The stylet of claim 1, wherein the s-shaped curve has two curves, the first curve forming a first angle of 120 to 160 degrees and the second curve forming an angle of 120 to 160 degrees.
8. The stylet of claim 1, wherein the s-shaped curve has a first curve and a second curve, the  
30 second curve distal to the first curve, and wherein the pre-shaped curve is aligned in substantially the same direction as the second curve.
9. The stylet of claim 1, wherein the pointed distal end includes an anchor.
- 35 10. A method of re-entering a true lumen during occlusion-crossing comprising:

orienting a distal end of a catheter having a bend therein towards the true lumen of a vessel;

introducing a stylet through a guidewire channel of the catheter until a curved middle portion of the stylet aligns with the bend in the catheter and a pointed distal end of the stylet extends out of a distal end of the catheter;

advancing the stylet such that the pointed distal end pierces through a wall of the vessel; and

directing the catheter over the stylet and into the true lumen of the vessel.

11. The method of claim 10, further comprising orienting the stylet within the catheter such that the pointed distal end of the stylet curves towards the vessel wall before advancing the stylet.

12. The method of claim 10, further comprising reorienting the catheter within the true lumen after directing the catheter over the stylet.

13. The method of claim 12, wherein reorienting the catheter comprises reorienting without puncturing the an opposite vessel wall.

14. The method of claim 10, further comprising determining an orientation of the stylet based upon an alignment of the curved middle portion with the bend in the catheter.

15. The method of claim 10, wherein the catheter further includes a proximal portion, the proximal portion and the curved middle portions having substantially circular cross-sections, and wherein the pointed distal end has a flatted portion having a substantially oblong cross-section.

16. The method of claim 10, further comprising using image guidance to orient the catheter.

17. An assembly for re-entry into a vessel comprising:

a catheter having a pre-set curve; and

a stylet having an elongate body, the elongate body having a proximal portion, a middle flexible portion, and a distal stiff portion,

wherein, when the stylet is inserted into the catheter, the flexible portion is configured to conform to the pre-set curve and the distal stiff portion is configured to at least partially

straighten the pre-set curve; and

wherein the flexible portion has a length such that the flexible portion can align with the pre-set curve both while the distal stiff portion remains inside the catheter and while the distal stiff portion extends distally from a distal end of the catheter.

- 5 18. The assembly of claim 17, wherein the distal stiff portion comprises a sharp pointed end.
19. The assembly of claim 17, wherein the middle flexible portion comprises a flexible coil.
20. The assembly of claim 17, wherein the proximal portion is stiffer than the middle flexible  
10 portion.
21. The assembly of claim 17, wherein the middle flexible portion has a reduced thickness relative to the proximal portion.
- 15 22. An assembly for re-entry into a vessel comprising:  
a catheter having a pre-set curve; and  
a stylet comprising:  
a flexible elongate body having a pointed distal end; and  
a stiff tube concentric with the flexible elongate body, the flexible elongate body  
20 axially movable relative to the stiff tube;  
wherein, when the stylet is inserted into the catheter, the flexible portion is configured to conform to the pre-set curve and the flexible elongate body is configured to at least partially straighten the pre-set curve.
- 25 23. The assembly of claim 22, wherein the flexible elongate body comprises a pre-set curve configured to match the pre-set curve of the catheter.
24. The assembly of claim 22, wherein the flexible elongate body comprises a shape memory  
30 material.
25. A stylet for re-entry into a vessel comprising:  
an elongate body having a pointed distal tip; and  
a coiled member attached to the pointed distal tip, the coiled member having a relaxed configuration where the coiled member extends over the pointed distal portion and a compressed

configuration wherein the coiled member is compressed to expose at least a portion of the pointed distal tip.

5

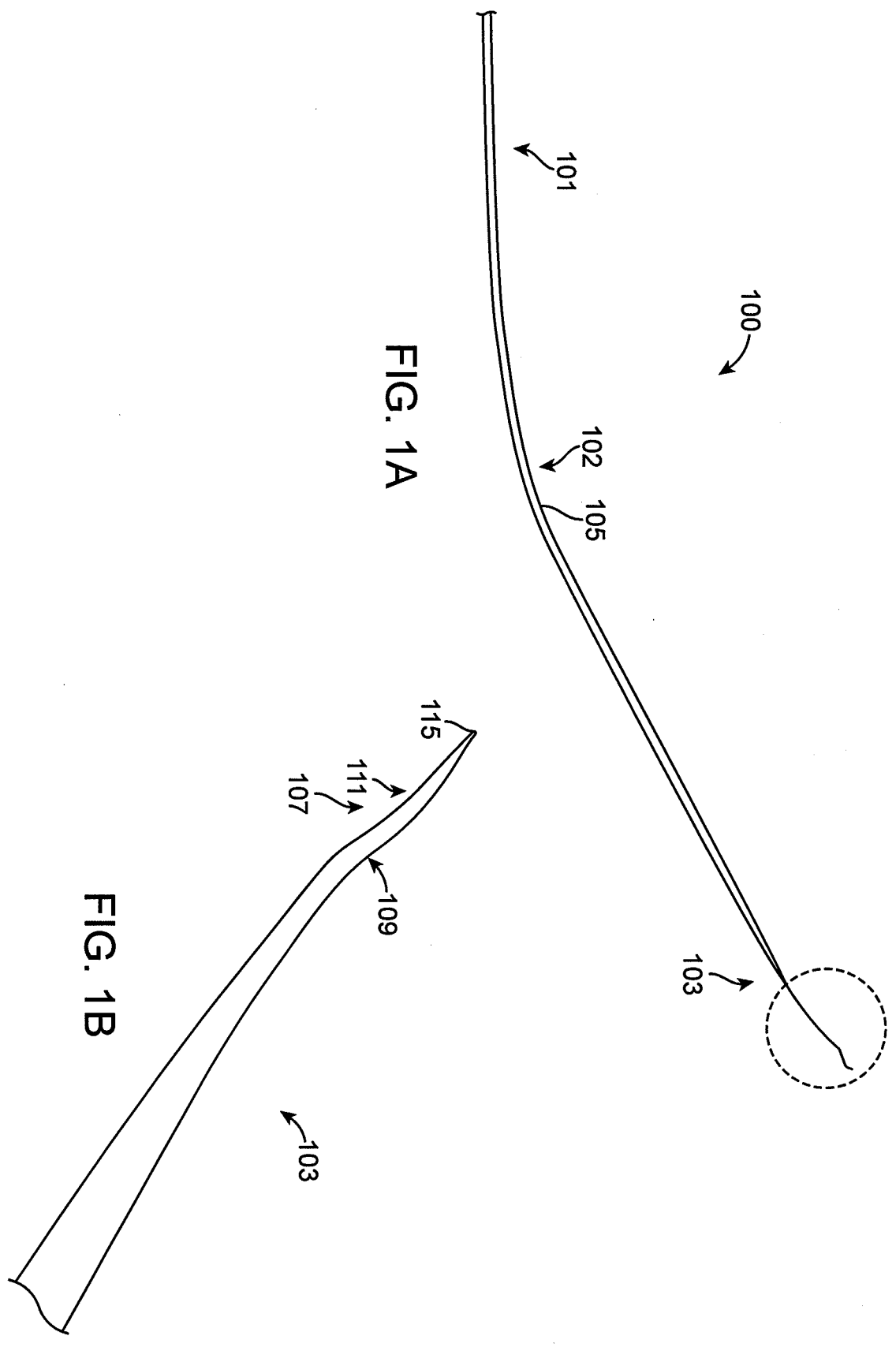

FIG. 1A

FIG. 1B

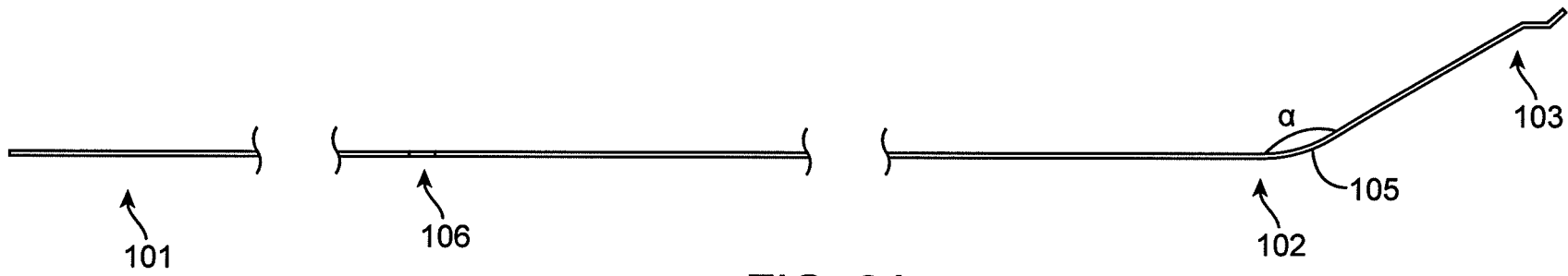

FIG. 2A

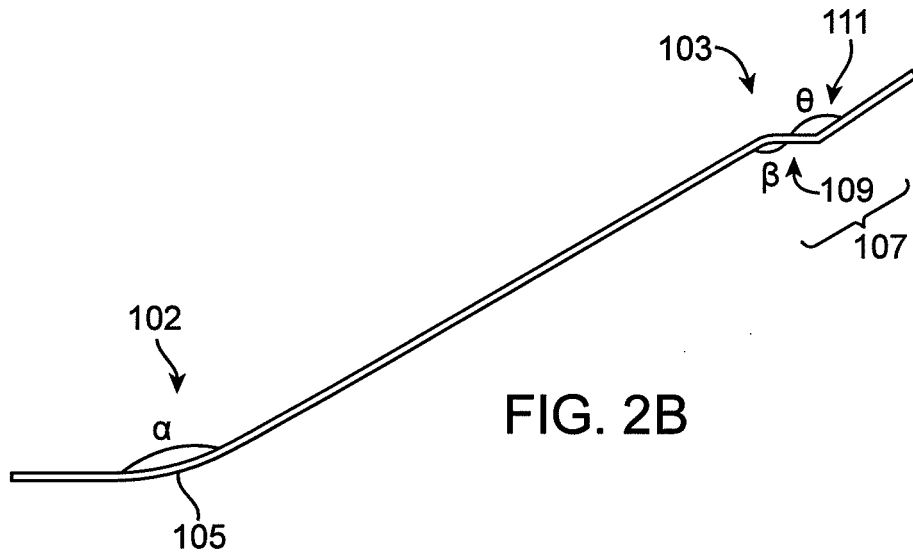

FIG. 2B

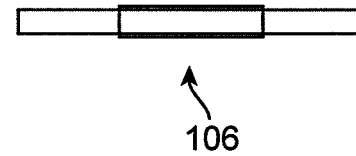

FIG. 2C

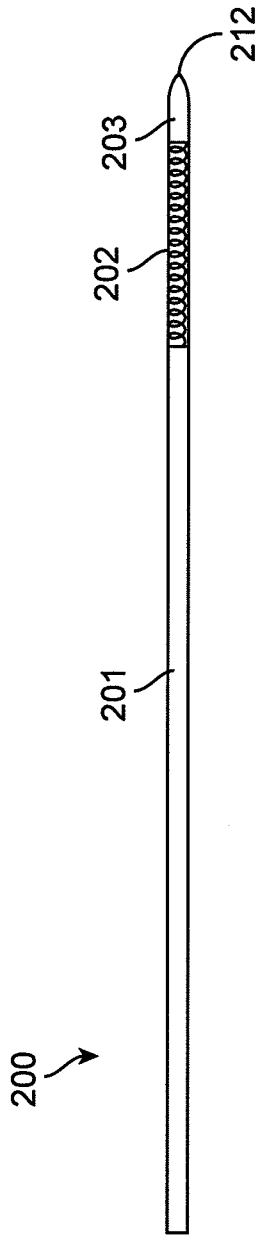

FIG. 3A

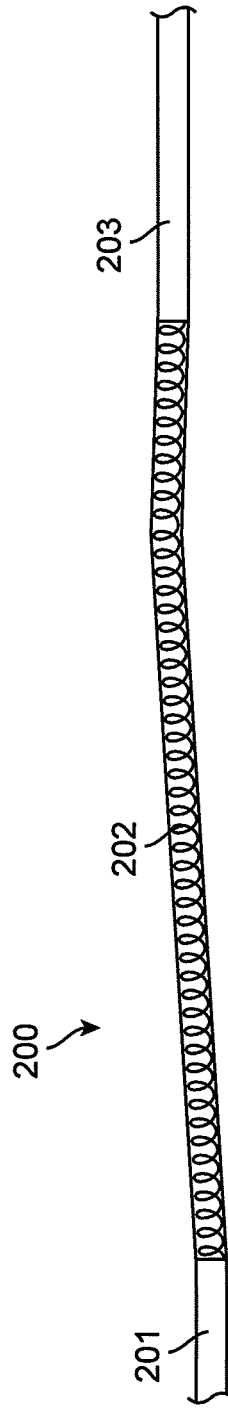

FIG. 3B



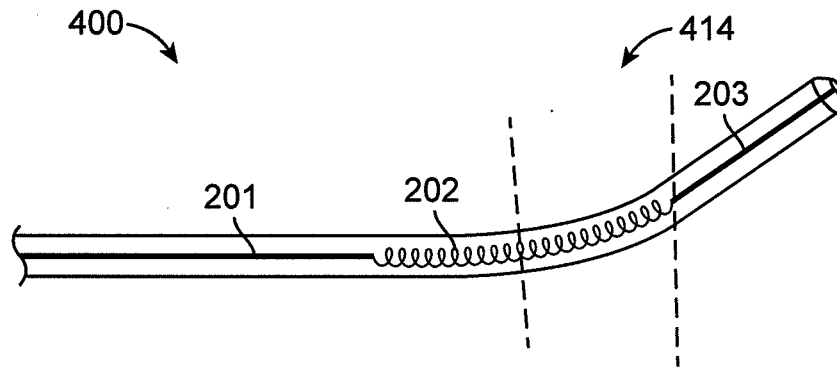

FIG. 4A

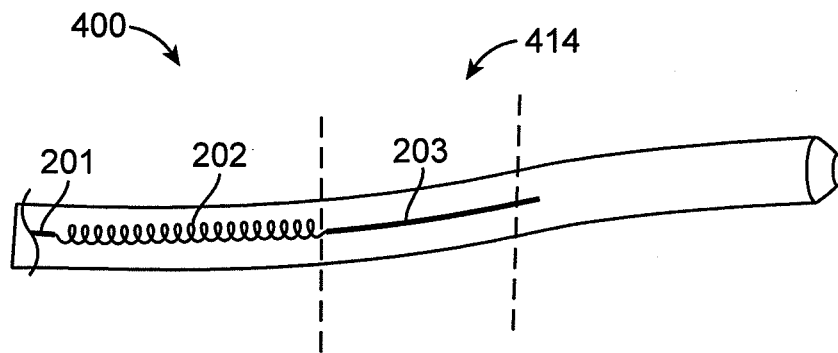

FIG. 4B

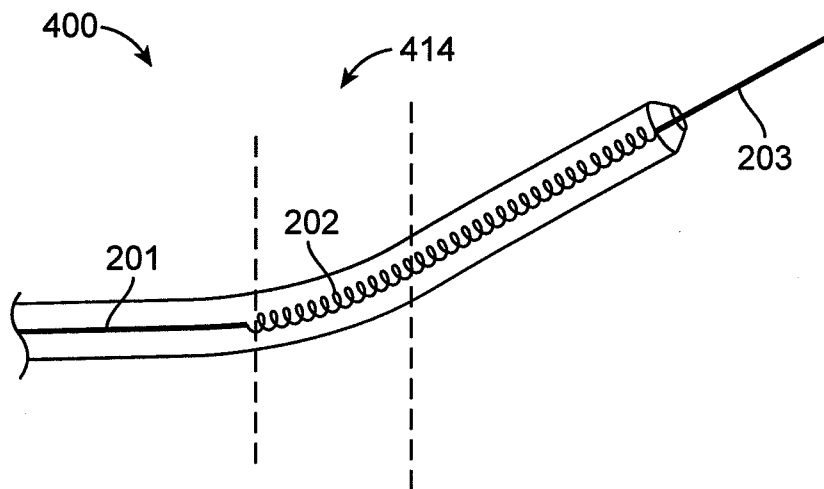

FIG. 4C

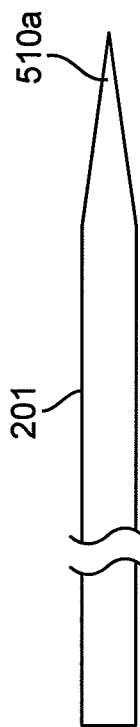

FIG. 5A

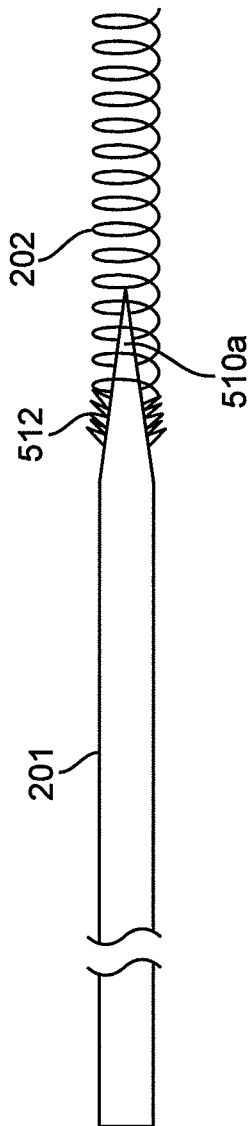

FIG. 5B

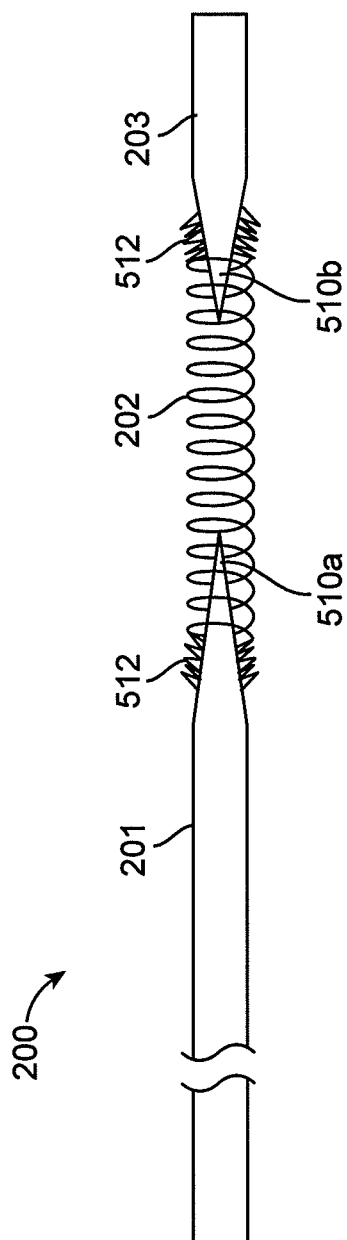

FIG. 5C

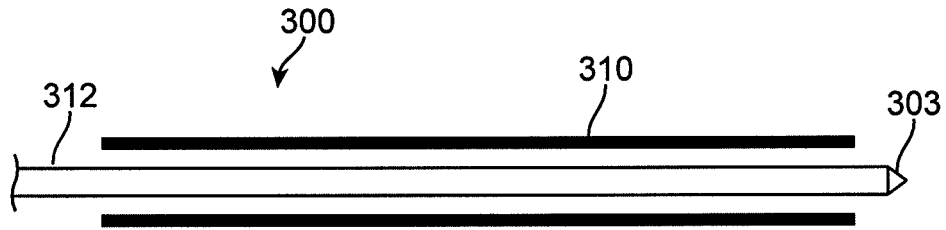

FIG. 6

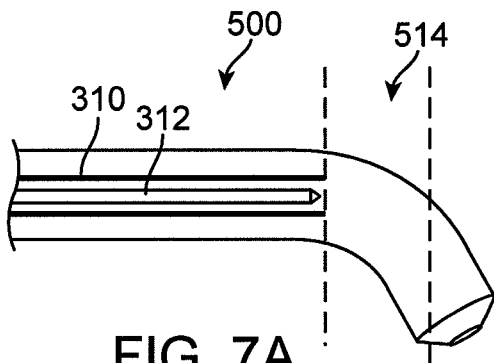

FIG. 7A

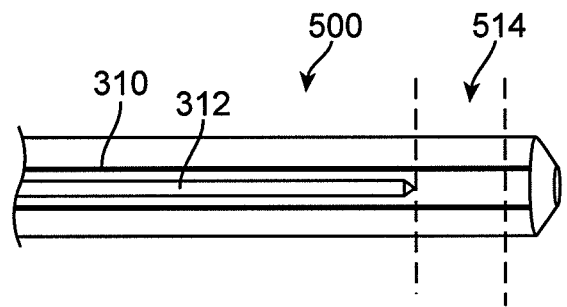

FIG. 7B

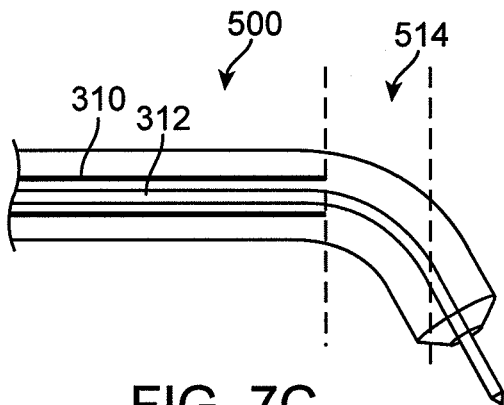

FIG. 7C

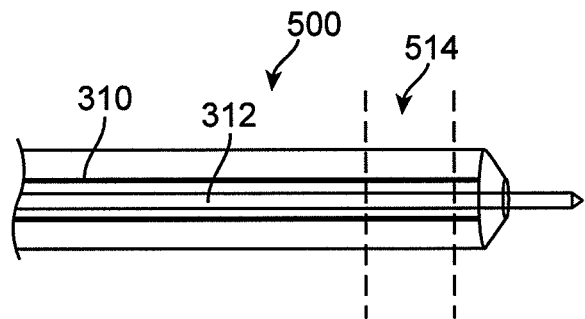

FIG. 7D

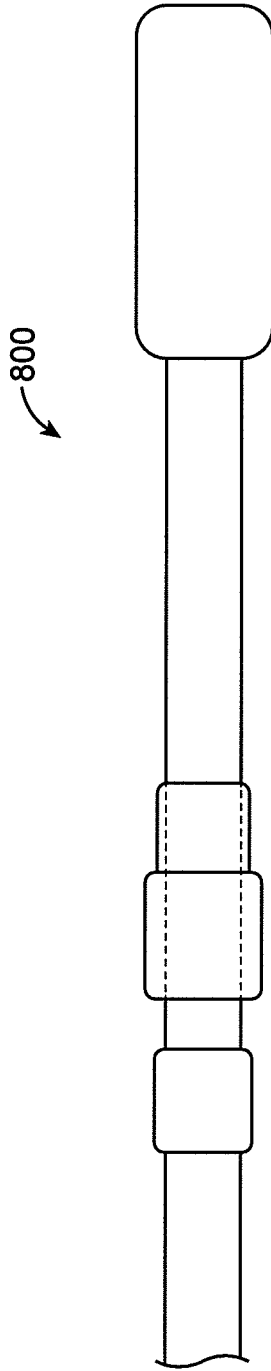

FIG. 8

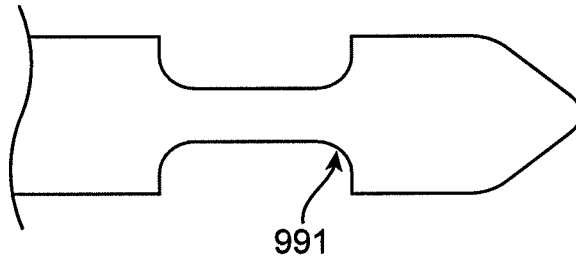

FIG. 9A

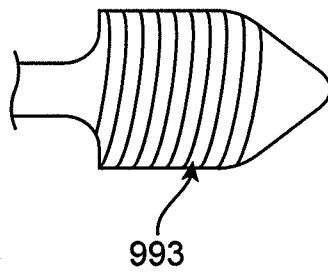

FIG. 9B

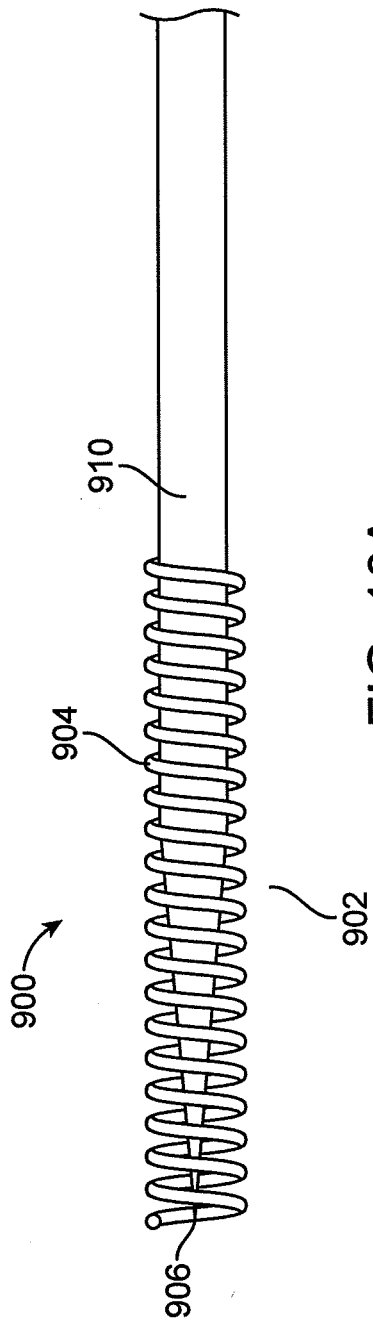

FIG. 10A

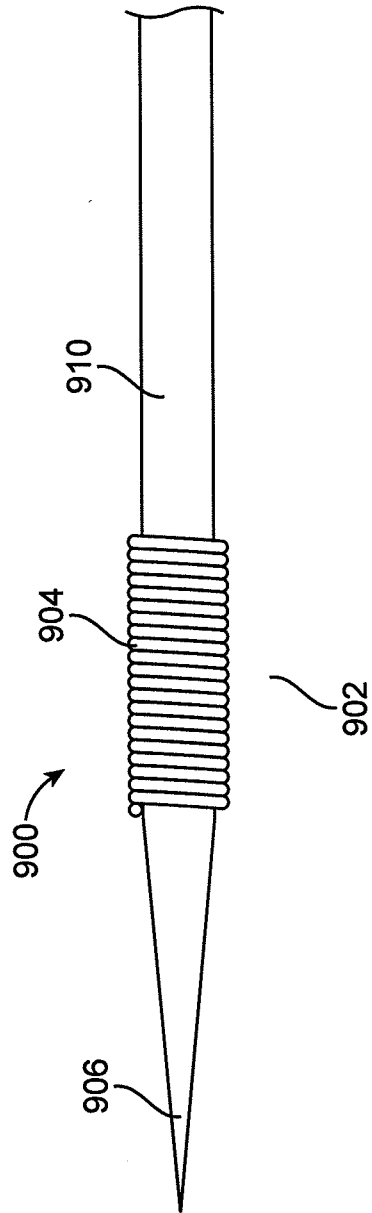

FIG. 10B

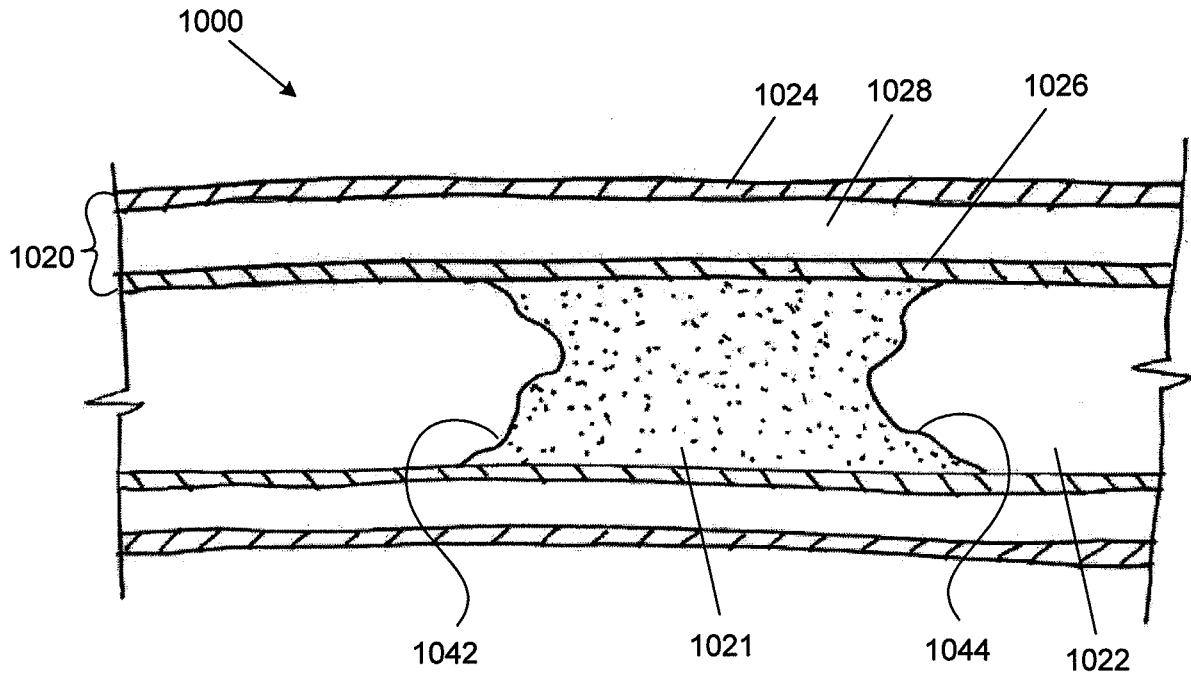

FIG. 11A

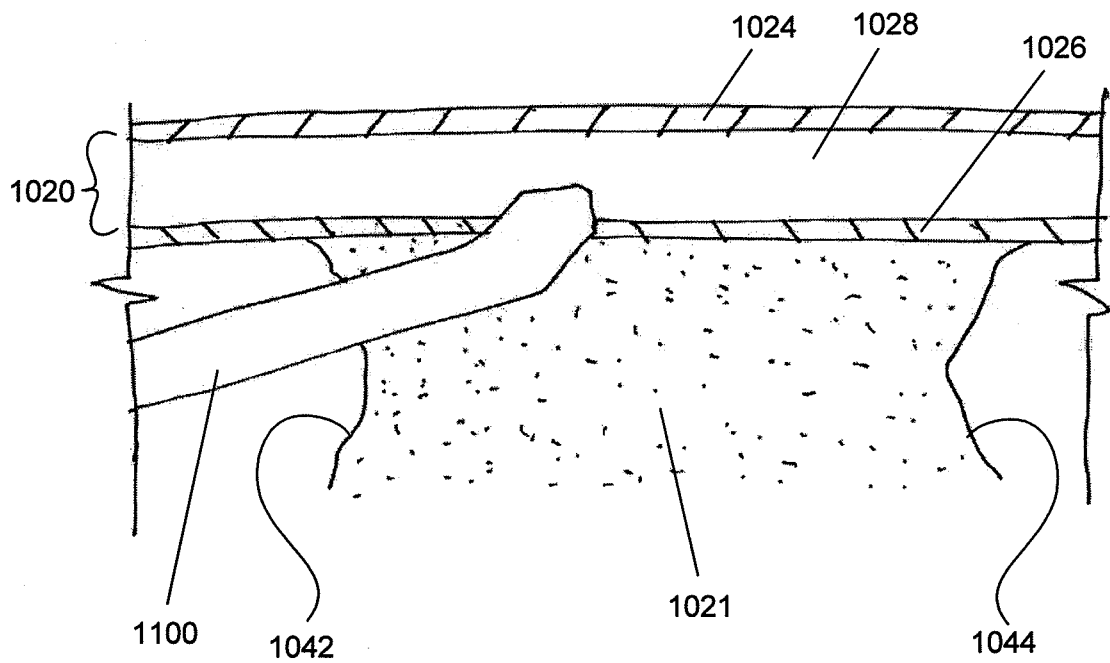

FIG. 11B

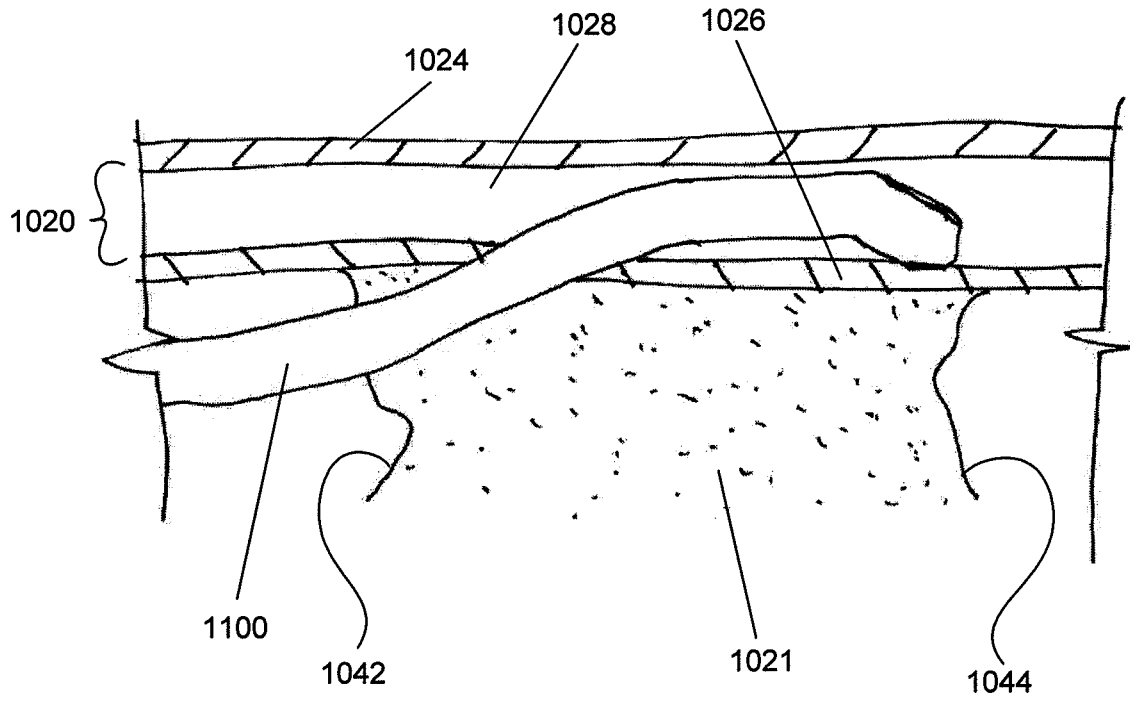

FIG. 11C



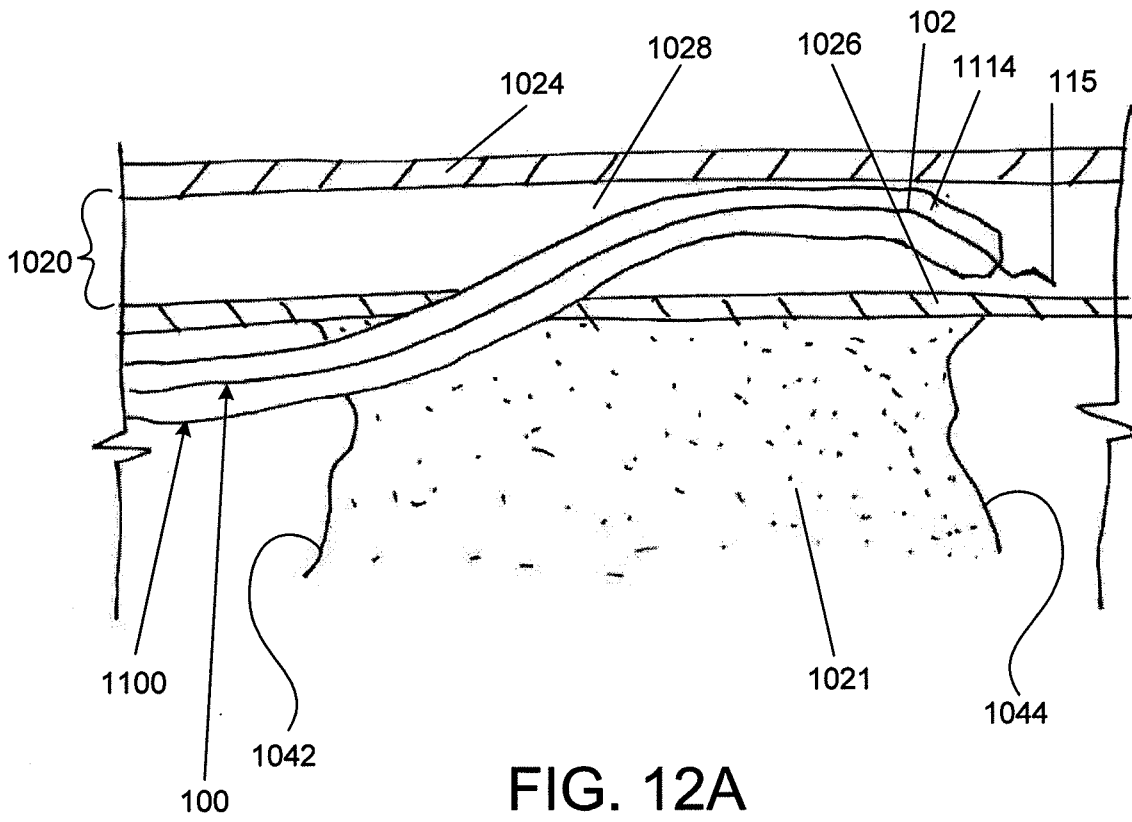

FIG. 12A

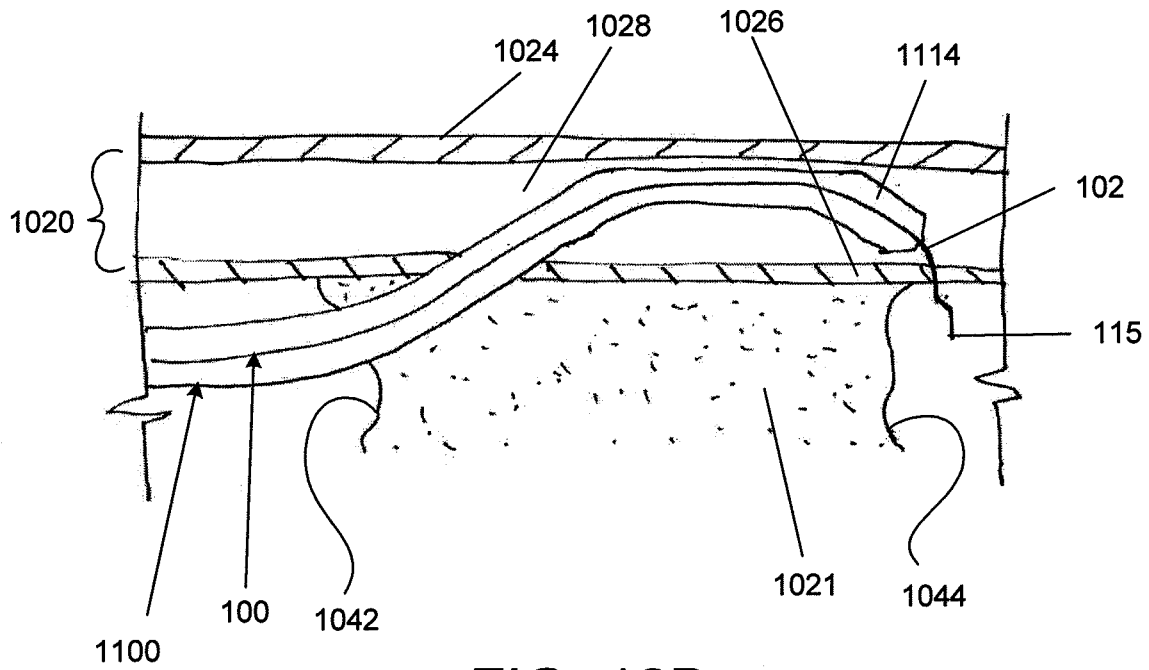

FIG. 12B

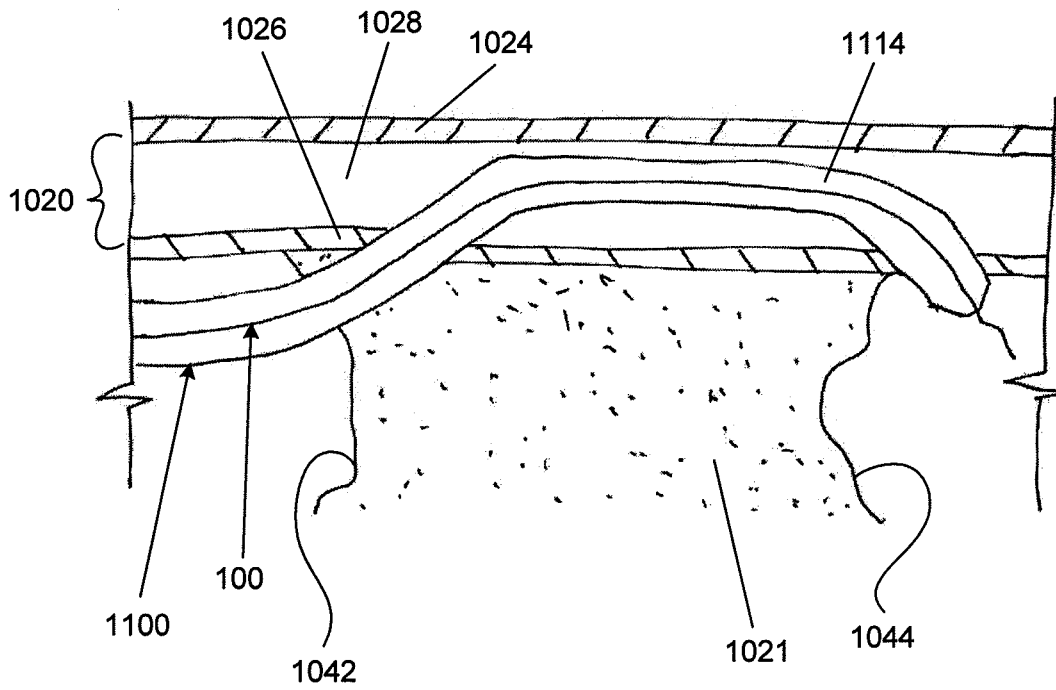

FIG. 12C

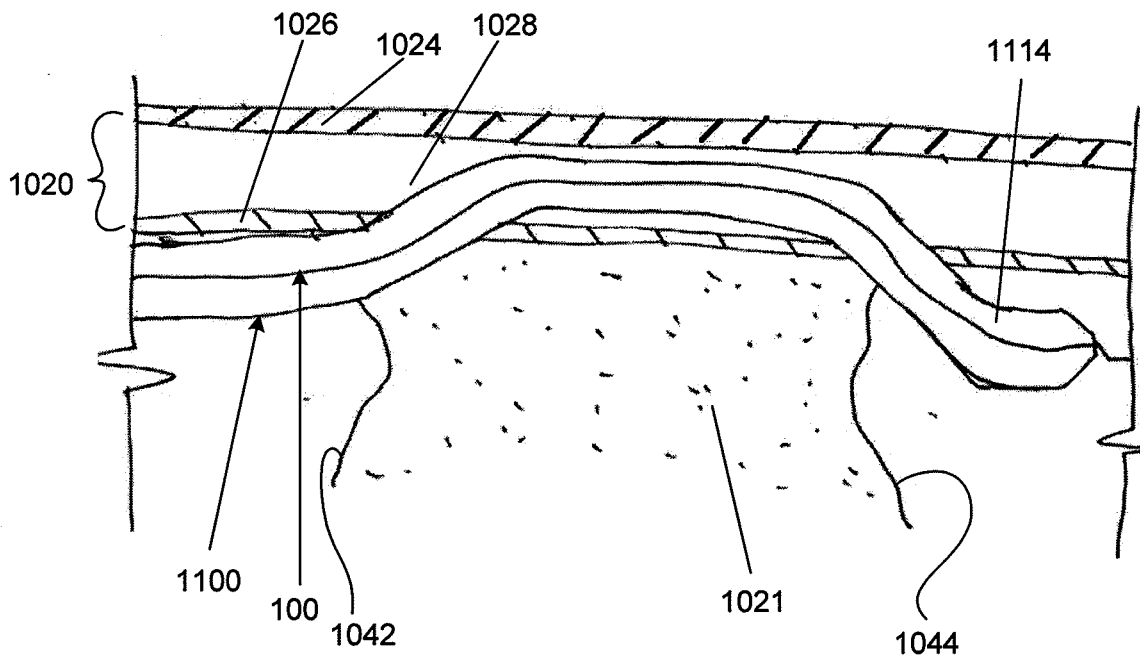

FIG. 12D

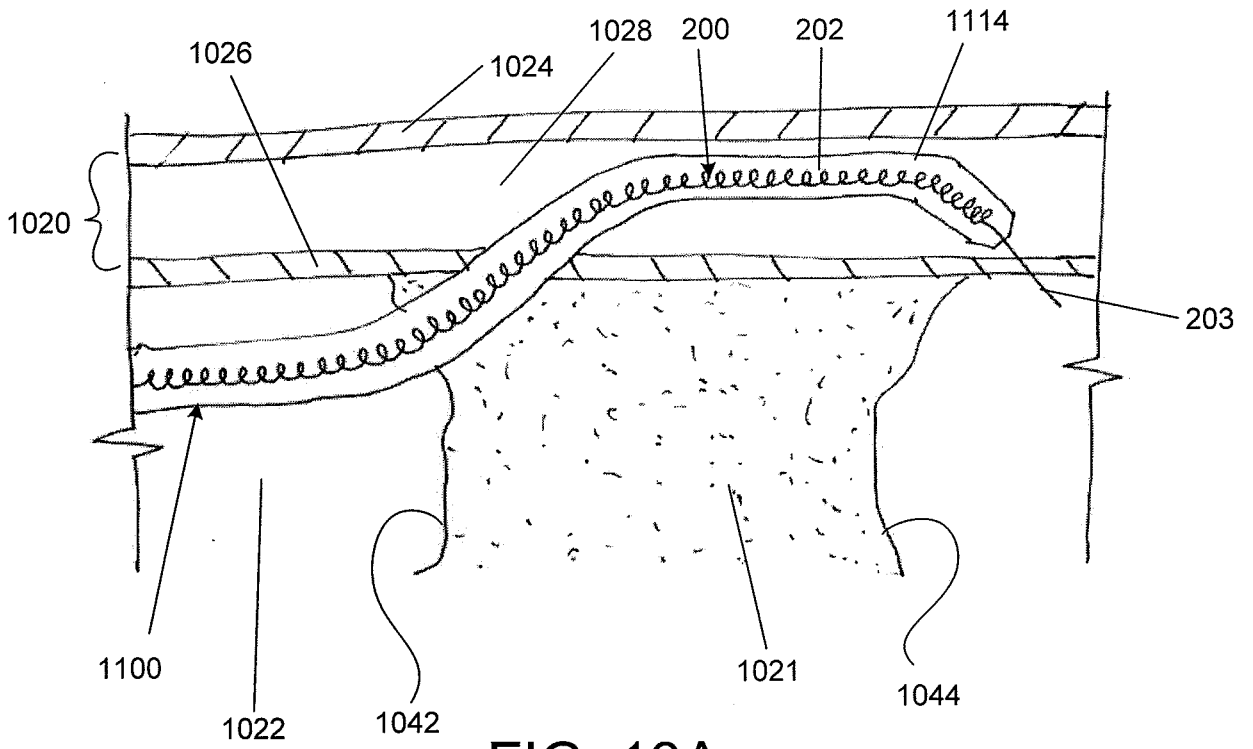

FIG. 13A

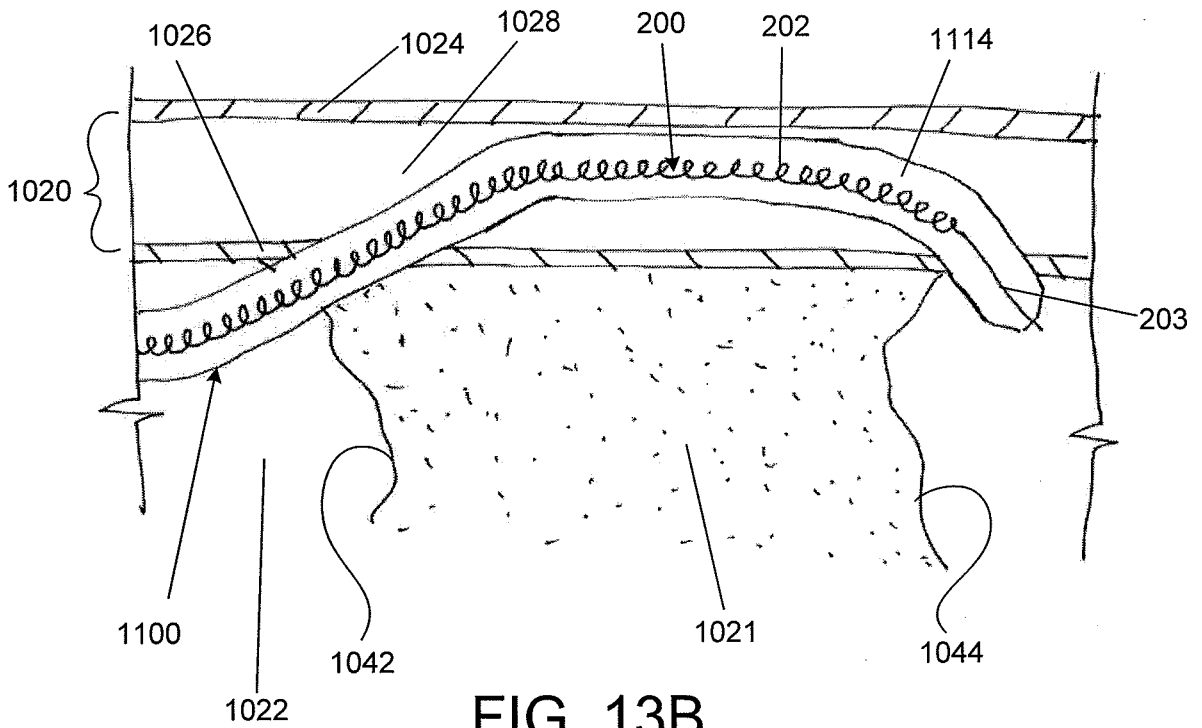

FIG. 13B

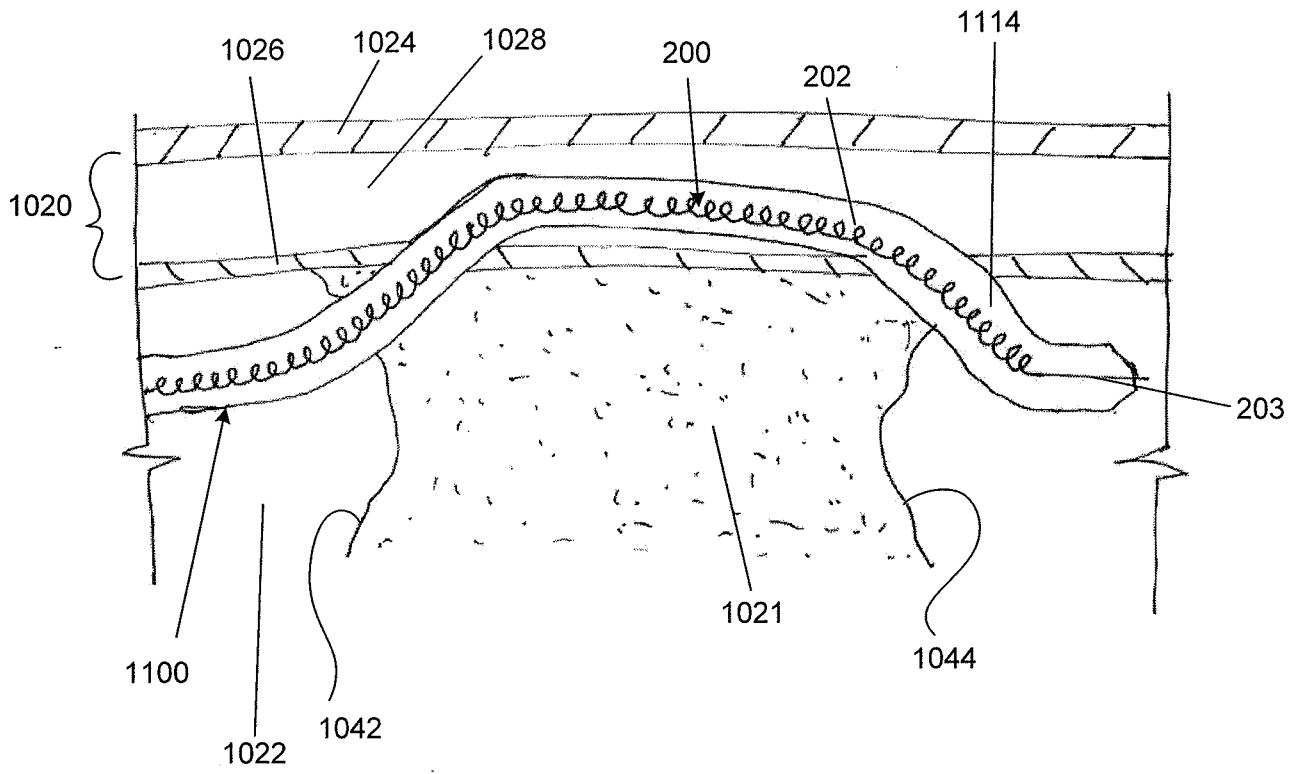

FIG. 13C

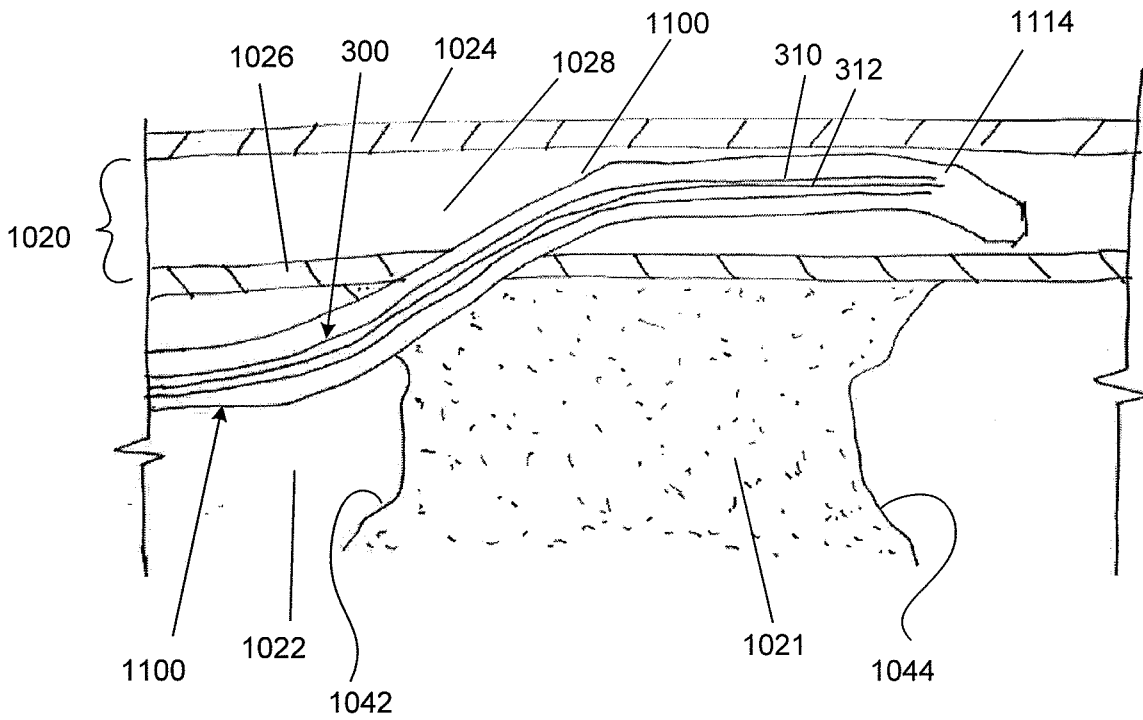

FIG. 14A

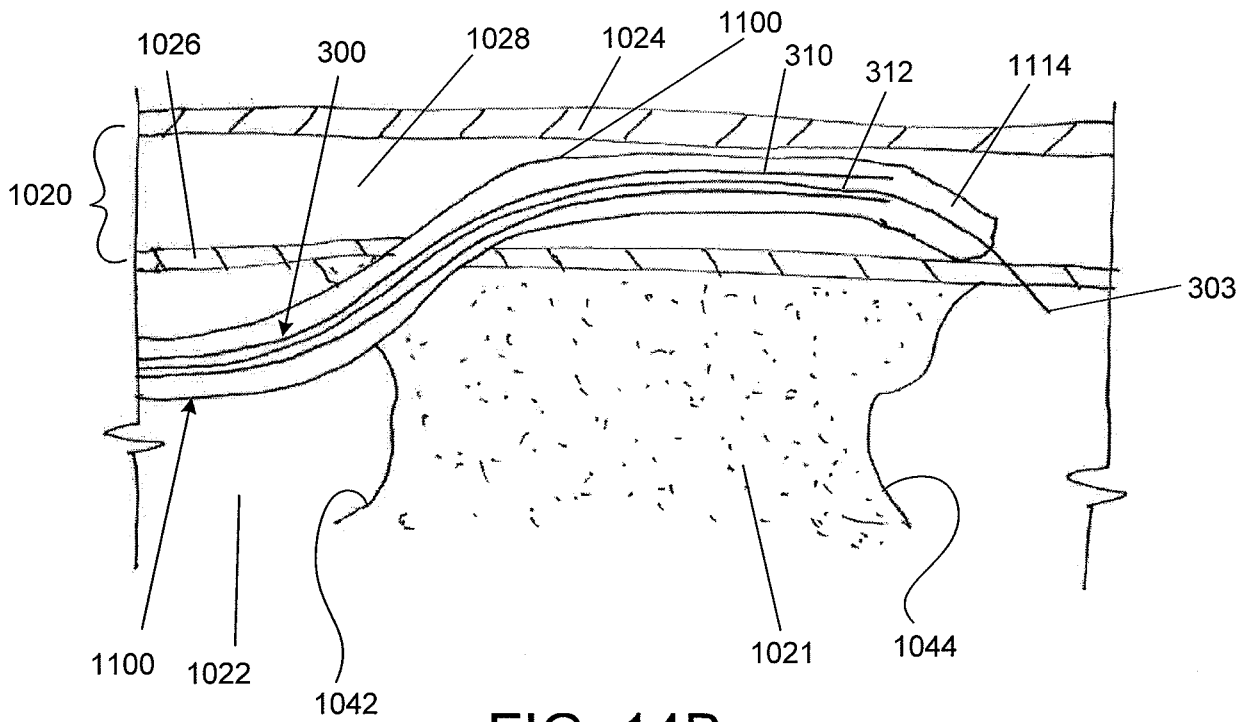

FIG. 14B

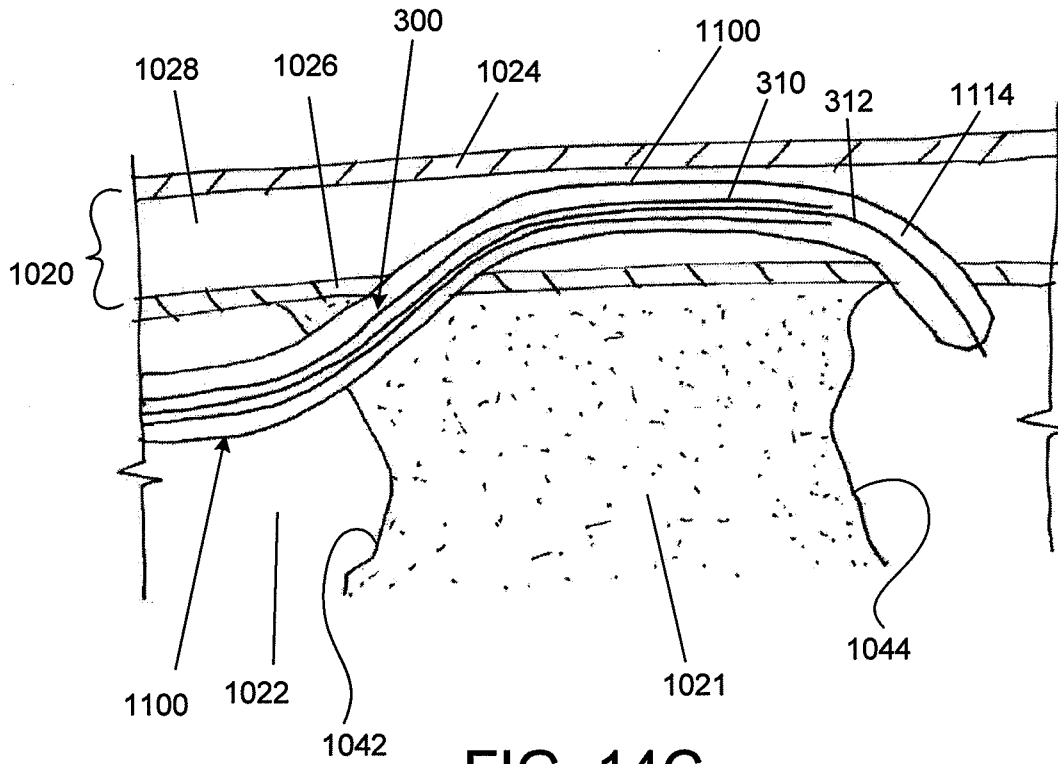

FIG. 14C

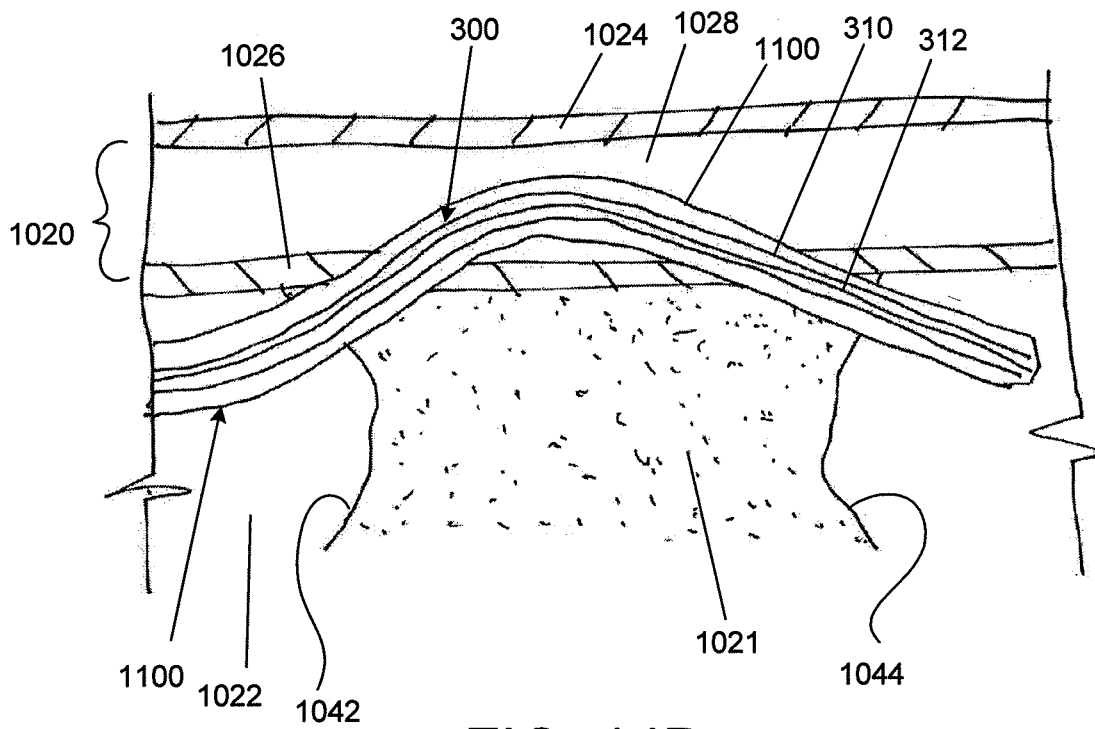

FIG. 14D

**A. CLASSIFICATION OF SUBJECT MATTER****A61M 25/06(2006.01)i, A61B 1/04(2006.01)i**

According to International Patent Classification (IPC) or to both national classification and IPC

**B. FIELDS SEARCHED**

Minimum documentation searched (classification system followed by classification symbols)

A61M 25/06; A61B 5/01; A61M 25/08; A61M 25/01; A61B 8/12; A61M 25/09; A61B 17/22; A61M 5/178; A61B 1/04

Documentation searched other than minimum documentation to the extent that such documents are included in the fields searched

Korean utility models and applications for utility models

Japanese utility models and applications for utility models

Electronic data base consulted during the international search (name of data base and, where practicable, search terms used)

eKOMPASS(KIPO internal) &amp; Keywords: stylet, catheter, re-entry, peripheral artery, true lumen, pre-shaped, s-curve, flexible, stiff, stainless, nitinol, shape memory

**C. DOCUMENTS CONSIDERED TO BE RELEVANT**

Category*	Citation of document, with indication, where appropriate, of the relevant passages	Relevant to claim No.
X	US 5807339 A (BOSTROM, M.) 15 September 1998 See claim 1; column 3, lines 41-55; column 4, lines 66-67; figures 1-2, 4.	17-25
Y		1-9
Y	US 2010-0317973 A1 (NITA, H.) 16 December 2010 See paragraph [0023], paragraph [0040]; figures 4-11.	1-9
A		17-25
A	US 2009-0264826 A1 (THOMPSON, D.) 22 October 2009 See abstract; claim 1; figures 1A-1B, 4D-4E.	1-9, 17-25
A	WO 91-17698 A1 (BRIGHAM AND WOMEN'S HOSPITAL) 28 November 1991 See abstract; claim 1; figures 1-3.	1-9, 17-25
A	US 2004-0039371 A1 (TOCKMAN, B. et al.) 26 February 2004 See abstract; claim 1; figures 2A-2C.	1-9, 17-25



Further documents are listed in the continuation of Box C.



See patent family annex.

\* Special categories of cited documents:

"A" document defining the general state of the art which is not considered to be of particular relevance

"E" earlier application or patent but published on or after the international filing date

"L" document which may throw doubts on priority claim(s) or which is cited to establish the publication date of citation or other special reason (as specified)

"O" document referring to an oral disclosure, use, exhibition or other means

"P" document published prior to the international filing date but later than the priority date claimed

"T" later document published after the international filing date or priority date and not in conflict with the application but cited to understand the principle or theory underlying the invention

"X" document of particular relevance; the claimed invention cannot be considered novel or cannot be considered to involve an inventive step when the document is taken alone

"Y" document of particular relevance; the claimed invention cannot be considered to involve an inventive step when the document is combined with one or more other such documents, such combination being obvious to a person skilled in the art

"&amp;" document member of the same patent family

Date of the actual completion of the international search

26 June 2013 (26.06.2013)

Date of mailing of the international search report

**28 June 2013 (28.06.2013)**

Name and mailing address of the ISA/KR



 Korean Intellectual Property Office  
 189 Cheongsa-ro, Seo-gu, Daejeon Metropolitan City,  
 302-701, Republic of Korea

Facsimile No. 82-42-472-7140

Authorized officer

KIM, Sung Gon

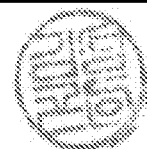
Telephone No. 82-42-481-8746



**Box No. II Observations where certain claims were found unsearchable (Continuation of item 2 of first sheet)**

This international search report has not been established in respect of certain claims under Article 17(2)(a) for the following reasons:

1.  Claims Nos.: 10-16  
because they relate to subject matter not required to be searched by this Authority, namely:  
**Claims 10-16 pertain to methods for treatment of the human and thus relate to a subject-matter which this International Searching Authority is not required, under Article 17(2)(a)(i) of the PCT and Rule 39.1(iv) of the Regulations under the PCT, to search.**
2.  Claims Nos.:  
because they relate to parts of the international application that do not comply with the prescribed requirements to such an extent that no meaningful international search can be carried out, specifically:
3.  Claims Nos.:  
because they are dependent claims and are not drafted in accordance with the second and third sentences of Rule 6.4(a).

**Box No. III Observations where unity of invention is lacking (Continuation of item 3 of first sheet)**

This International Searching Authority found multiple inventions in this international application, as follows:

1.  As all required additional search fees were timely paid by the applicant, this international search report covers all searchable claims.
2.  As all searchable claims could be searched without effort justifying an additional fee, this Authority did not invite payment of any additional fee.
3.  As only some of the required additional search fees were timely paid by the applicant, this international search report covers only those claims for which fees were paid, specifically claims Nos.:
  
4.  No required additional search fees were timely paid by the applicant. Consequently, this international search report is restricted to the invention first mentioned in the claims; it is covered by claims Nos.:

**Remark on Protest**

- The additional search fees were accompanied by the applicant's protest and, where applicable, the payment of a protest fee.
- The additional search fees were accompanied by the applicant's protest but the applicable protest fee was not paid within the time limit specified in the invitation.
- No protest accompanied the payment of additional search fees.



**INTERNATIONAL SEARCH REPORT**

Information on patent family members

International application No.  
**PCT/US2013/032196**

Patent document cited in search report	Publication date	Patent family member(s)	Publication date
US 05807339 A	15.09.1998	DE 69633265 D1 EP 0778044 A3 JP 09-173464 A	07.10.2004 09.07.1997 08.07.1997
US 2010-0317973 A1	16.12.2010	US 2012-283571 A1	08.11.2012
US 2009-0264826 A1	22.10.2009	US 8374680 B2	12.02.2013
WO 91-17698 A1	28.11.1991	AU 7894191 A CA 2083043 A1 EP 0528948 A1 JP 05-508332 A US 5054501 A WO 91-17698 A1	10.12.1991 17.11.1991 03.03.1993 25.11.1993 08.10.1991 28.11.1991
US 2004-0039371 A1	26.02.2004	AU 2003-258329 A1 EP 1534373 A2 EP 1970089 A2 JP 2005-536262 A US 2009-0177120 A1 US 2010-0114114 A1 WO 2004-018029 A2 WO 2004-018029 A3	11.03.2004 01.06.2005 17.09.2008 02.12.2005 09.07.2009 06.05.2010 04.03.2004 03.06.2004