

P. H. GRACE.
SPARK-ARRESTER.

No. 193,242.

Patented July 17, 1877.

Fig. 1.

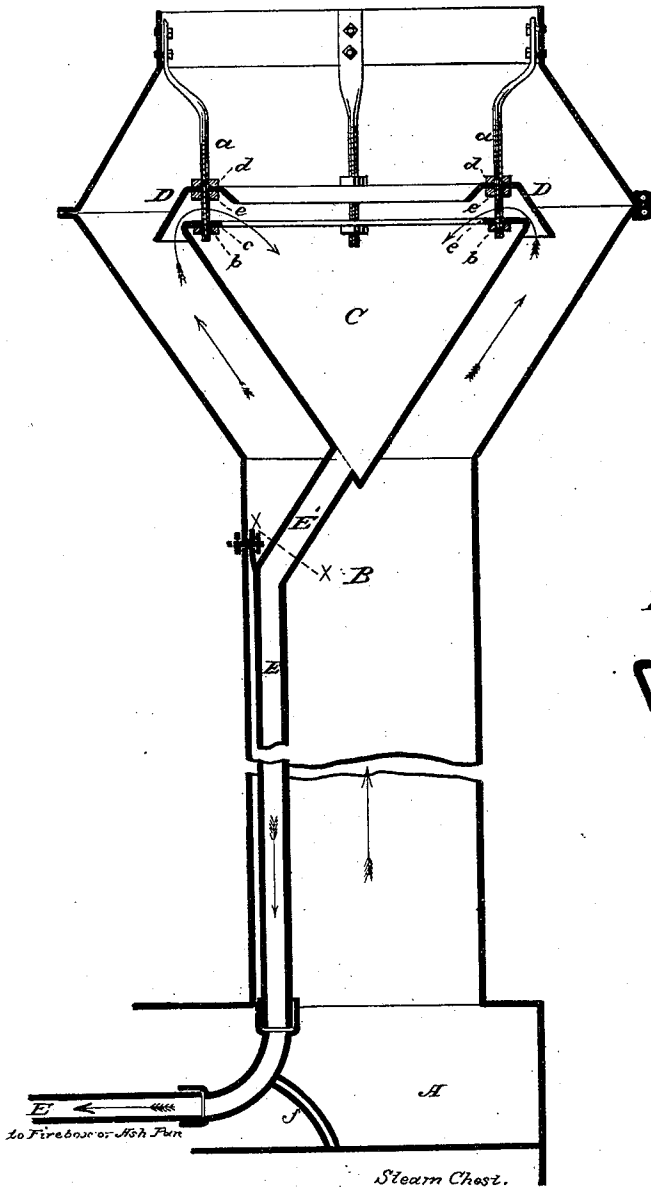

Fig. 2.



Attest
Jno. P. Brooks
August Peterson.

Inventor:
Patrick H. Grace,
by Louis Baggett
attys.

UNITED STATES PATENT OFFICE.

PATRICK H. GRACE, OF SEDALIA, MISSOURI.

IMPROVEMENT IN SPARK-ARRESTERS.

Specification forming part of Letters Patent No. 193,242, dated July 17, 1877; application filed June 19, 1877.

To all whom it may concern :

Be it known that I, PATRICK HENRY GRACE, of Sedalia, in the county of Pettis and State of Missouri, have invented certain new and useful Improvements in Spark-Arrester; and I do hereby declare that the following is a full, clear, and exact description thereof, which will enable others skilled in the art to which it appertains to make and use the same, reference being had to the accompanying drawings, which form a part of this specification, and in which—

Figure 1 is a vertical section, and Fig. 2 is a cross-section, of the spark-conveyer on the line *x x*, Fig. 1.

Similar letters of reference indicate corresponding parts in both the figures.

My invention relates to devices for arresting sparks in the smoke-stacks of locomotives, steamboats, and portable or stationary engines; and it consists in the construction and combination of parts, substantially as hereinafter more fully described, and pointed out in the claim.

In the drawings, A is the smoke-box, and B the stack, of a locomotive, represented in vertical section. Inserted into the funnel-shaped mouth or bonnet of the stack is an inverted cone, C, which is secured in place by screw-threaded rods *a*, bolted onto the inner rim of the top of the stack, and provided with nuts *b*, which fit in under the upper annular rim or flange *c* of the cone C, which is perforated, to allow rods *a* to pass through. Instead of the flange *c* brackets may be used, projecting from the inner upper rim of the cone, which will answer the same purpose.

Placed directly over the rim of cone C is an annular cup or ring, D, semi-hexagonal in its section, and projecting over or overlapping the rim of cone C on its outer and inner sides. The rods *a* passing vertically through the top of ring D, this may be raised or lowered by means of jam-nuts *d e*, placed, respectively, on the rods *a*, above and below the ring D, which they serve to keep in place, and to adjust.

E is the spark-conveyer, the upper bent end of which enters hopper or cone C at its bottom. It is then passed downward along the inner side of the stack to the smoke-box A, where it is, with the aid of an elbow, bent at a right angle, and passes back to the fire-box or ash-pan.

A small pipe, *f*, is passed from the exhaust-ports or steam-chests of the engines into the horizontal arm of conductor E, for the double purpose of drawing the sparks and dust from the cone into the pipe or conveyer, and blowing them through this into the fire-box or ash-pan.

The upper bent portion of conveyer E (denoted by E' on the drawing) rests in a triangular or wedge-shaped jacket, *g*, as represented on Fig. 2, and the vertical portion, which passes down the inner side of the smoke-stack, is flattened or oval in its section, so as to afford the least possible resistance to the draft.

From the foregoing description, the operation of my invention will be readily understood. The smoke, sparks, and exhaust steam passing up through the stack are met by the pointed cone, which causes them to divert or spread, seeking escape out into the open air around it. The smoke and steam, having a natural tendency to spread, will partly escape through the outer oblique rim of ring D and the sides of the stack, and partly over the rim of the cone C, (between it and the ring or deflector D,) and up through the opening in the latter; but the sparks, whose impulse is in a straight or perpendicular line, will strike the ring or deflector D, and will by it be thrown back into the cone C, from which they are emptied through the pipe or conveyer E.

By raising or lowering the deflector D in the manner described, the draft in the stack may be regulated at pleasure.

Having thus described my invention, I claim and desire to secure by Letters Patent of the United States—

The combination of the stack B, having vertical bolts or rods *a*, with the inverted cone C, conveyer E, and adjustable annular deflector D, substantially as and for the purpose herein shown and described.

In testimony that I claim the foregoing as my own I have hereto affixed my signature in presence of two witnesses.

PATRICK HENRY GRACE.

Witnesses :

JAMES GRAY,
A. C. SCOTT.