



(22) Date de dépôt/Filing Date: 2004/09/03  
(41) Mise à la disp. pub./Open to Public Insp.: 2005/03/03  
(30) Priorité/Priority: 2003/09/03 (10/654,742) US

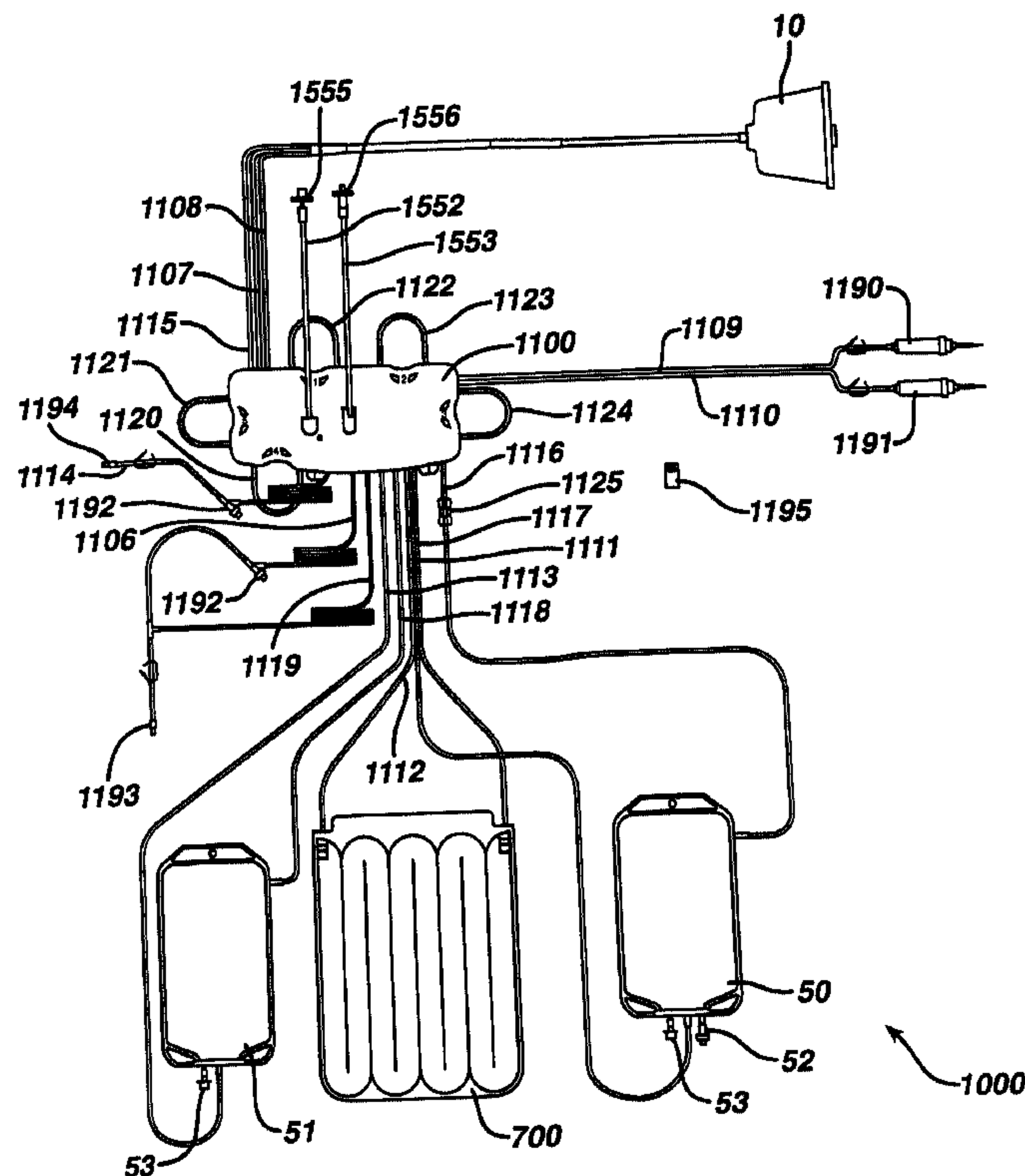
(51) Cl.Int.<sup>7</sup>/Int.Cl.<sup>7</sup> B01D 17/038, A61M 1/36, B04B 7/02

(71) Demandeur/Applicant:  
THERAKOS, INC., US

(72) Inventeurs/Inventors:  
BRIGGS, DENNIS, US;  
GARA, STEVE, US;  
WATTERS, TOM, US;  
HUTCHINSON, MIKE, US

(74) Agent: OGILVY RENAULT

(54) Titre : APPAREIL AMELIORE POUR LA SEPARATION CONTINUE DES LIQUIDES BIOLOGIQUES DANS DES COMPOSANTS, ET METHODE D'UTILISATION  
(54) Title: IMPROVED APPARATUS FOR THE CONTINUOUS SEPARATION OF BIOLOGICAL FLUIDS INTO COMPONENTS AND METHOD OF USING SAME



(57) Abrégé/Abstract:

The present invention provides an apparatus for separating components of a fluid having an outer housing containing a core wherein three separate fluid pathways are provided to allow continuous separation of biological fluids.

**Abstract**

The present invention provides an apparatus for separating components of a fluid having an outer housing containing a core wherein three separate fluid pathways are provided to allow continuous separation of biological fluids.

# **IMPROVED APPARATUS FOR THE CONTINUOUS SEPARATION OF BIOLOGICAL FLUIDS INTO COMPONENTS AND METHOD OF USING SAME**

## **Cross-Reference to Related Applications**

[0001] This application is a continuation-in-part application of United States Patent Application 10/375,628, filed February 27, 2003, which claims the benefit of United States Provisional Application, Serial Number 60/361,287, filed March 4, 2002, both of which are hereby incorporated by reference in their entireties.

## **Technical Field of the Invention**

[0002] The present invention generally relates to methods and apparatus for separating a fluid into its components, for example, a biological or sensitive fluid such as blood, and specifically to methods and apparatus that use centrifugal force to separate a fluid into its components by density so as to improve the component yield.

## **Background Art**

[0003] With the advance of medical sciences, it has become possible to treat a patient's blood in closed-loop processes, returning the patient's own treated blood back to him in one medical treatment. An example of such processes include external treatment methods for diseases in which there is a pathological increase of lymphocytes, such as cutaneous T-cell lymphoma or other diseases affecting white blood cells. In such methods, the patient's blood is irradiated with ultraviolet light in the presence of a chemical or an antibody. Ultraviolet light affects the bonding between the lymphocytes and the chemical or antibody that inhibits the metabolic processes of the lymphocytes.

[0004] During one of these medical treatments, a centrifuge bowl, such as, for example, a Latham bowl, as shown in U.S. Patent No. 4,303,193, expressly incorporated by reference in its entirety herein, separates blood into red blood cells ("RBCs") and buffy coat. The Latham bowl is a blood component separator that has been used for some time in the medical apheresis market as well as in innovative medical therapies such as extracorporeal photopheresis (ECP). PCT Applications WO 97/36581 and WO 97/36634, and U.S. Patent Nos. 4,321,919; 4,398,906; 4,428,744; and 4,464,166 provide descriptions of extracorporeal photopheresis, and are hereby expressly incorporated by reference in their entirety.

[0005] The Latham bowl efficiency is often measured by the white blood cell ("WBC") "yield," which is typically about 50%. Yield is defined as the percentage of cells collected

versus the number processed. When compared to other types of whole blood separators, this high yield enables the Latham bowl separator to collect much larger volumes of WBCs while processing much less whole blood from the donor patient. However, a major drawback to the Latham bowl separator is that the separation process must be repeatedly stopped to remove the packed RBCs and plasma once they fill the inside of the bowl, creating a "batch-type" process. Although the Latham bowl separator has a high volume yield, the constant filling and emptying of this bowl wastes time; thus, the process is considered less efficient with respect to time. Additionally, the Latham bowl requires a rotating seal, which is expensive and difficult to manufacture.

[0006] An additional drawback of centrifugal processing apparatus has been their high cost of manufacture due to strict tolerances, rotating seals, and extensive manufacturing processes.

#### **Disclosure of the Invention**

[0007] The present invention provided an apparatus for separating components of a fluid comprising: an outer housing with an upper housing end and a lower housing end, wherein said outer housing increases in diameter from said upper housing end to said lower housing end, said lower housing end having a housing floor and said housing upper end having a housing outlet, said outer housing adapted for rotation about a center axis; said outer housing containing a core in said interior volume; the core having an outer wall, an upper core end, and a lower core end; said core connected with said outer housing for rotation therewith; and providing a separation volume between said core and said outer housing; said core end having a lumen connector and a lumen connector top surface; a first lumen for providing fluid communication from the housing outlet through the lumen connector and then radially outward through the core to the fluid separation volume; a second lumen providing fluid communications from the housing outlet extending axially along center axis to housing floor; a connection sleeve which forms with the lumen connector a chamber and provide fluid communications between the housing outlet and the separation volume.

[0008] In another embodiment of the present invention is provided a method for separating components of a fluid into a higher density component and a lower density component comprising: providing a centrifuge bowl have a first bowl channel, a second bowl channel, and a bowl chamber; flowing said fluid from a source into said centrifuge bowl through said first bowl channel; rotating said centrifuge bowl about an axis; removing said higher density

component from said bowl via said second bowl channel; and removing said lower density component from said bowl via said bowl chamber.

### **Brief Description of the Drawings**

**[0009]** The invention is described in detail with respect to the accompanying drawings, which illustrate an embodiment of the inventive apparatus, assemblies, systems, and methods.

FIG. 1 is a schematic representation of an embodiment of a disposable kit for use in photopheresis therapy embodying features of the present invention.

FIG. 2 is an elevated perspective view of an embodiment of a cassette for controlling fluid flow in the disposable photopheresis kit of FIG. 1.

FIG. 3 is an exploded view of the cassette of FIG. 2.

FIG. 4 is a top view of the cassette of FIG. 2 with the cover removed and showing internal tubular circuitry.

FIG. 5 is a bottom view of a cover of cassette of FIG. 2.

FIG. 6 is an elevated perspective view of an embodiment of a filter assembly.

FIG. 7 is bottom perspective view of the filter assembly of FIG. 6.

FIG. 8 is an exploded view of the filter assembly of FIG. 6.

FIG. 9 is a rear perspective view of the filter assembly of FIG. 6.

FIG. 10 is schematic representation of the filter assembly of FIG. 6 coupled to pressure sensors and a data processor.

FIG. 11 is a front view of an irradiation chamber.

FIG. 12 is a side longitudinal view of the irradiation chamber of FIG. 11.

FIG. 13 is a side transverse view of the irradiation chamber of FIG. 11

FIG. 14 is a cut-away view of a section of the first plate and the second plate prior to being joined together to form the irradiation chamber of FIG. 11.

FIG. 15 is a cut-away dimensional end view of the irradiation chamber of FIG. 11.

FIG. 16 is a perspective view of the irradiation chamber of FIG. 11 positioned within a UVA light assembly.

FIG. 17 is an elevated perspective view of an embodiment of a permanent tower system for use in conjunction with a disposable kit for facilitating a photopheresis therapy session.

FIG. 18 is a cross-sectional view of an embodiment of the photoactivation chamber, without a UVA light assembly, used in the tower system of FIG. 17.

FIG. 19 is a cross-sectional view of an embodiment of the centrifuge chamber used in the tower system of FIG. 17.

FIG. 20 is an electrical schematic of the leak detection circuit provided in the photoactivation chamber of FIG. 18.

FIG. 21 is an electrical schematic of the leak detection circuit provided in the centrifuge chamber of FIG. 19.

FIG. 22 is an elevated perspective view of an embodiment of the fluid flow control deck of the tower system of FIG. 17.

FIG. 23 is a perspective bottom view of the control deck of FIG. 22.

FIG. 24 is an exploded view of the control deck of FIG. 22.

FIG. 25 is a top perspective view of the control deck of FIG. 22 with the cassette of FIG. 2 loaded thereon.

FIG. 26 is a flowchart of an embodiment of a photopheresis treatment process.

FIG. 27 is a schematic of an embodiment of the fluid flow circuit used in performing the treatment process of FIG. 26.

FIG. 28 is top perspective view an embodiment of a peristaltic pump.

FIG. 29 is a cross sectional side view of the peristaltic pump of FIG. 28.

FIG. 30 is a top perspective view the rotor of the peristaltic pump of FIG. 29.

FIG. 31 is a bottom perspective view of the rotor of FIG. 30.

FIG. 32 is a top view of the peristaltic pump of FIG. 28.

FIG. 33 is a top view of the peristaltic pump of FIG. 28 in a loading position and near the cassette of FIG. 2.

FIG. 34 is an electrical schematic of the infrared communication port circuit.

FIG. 35 illustrates an embodiment of a centrifuge bowl and a rotating frame.

FIG. 36 is a dimensional view of the bowl of FIG. 35.

FIG. 37 is an exploded view of the bowl of FIG. 36.

FIG. 38 shows a cross sectional view of the bowl of FIG. 36 along the line XIX-XIX.

FIG. 39A shows a cross sectional view of a connection sleeve in place with a lumen connector of the bowl of FIG 38 along the line XX.

FIG. 39B shows another cross sectional view of a connection sleeve in place with a lumen connector of the bowl of FIG 38.

FIG. 40 shows a cross sectional view of the top core of the bowl of FIG. 37.

FIG. 41 shows a dimensional view of the top core and upper plate of FIG. 37.

FIG. 42 shows a bottom view of the top core of FIG. 41.

FIG. 43A shows a dimensional exploded view of the bottom core and a lower plate of the bowl of FIG. 37.

FIG. 43B shows an dimensional cross section view of the bottom core and a lower plate of the bowl of FIG. 43A attached together.

FIG. 44 shows an exploded side view of the bottom core and a lower plate of FIG. 43A.

FIG. 45 shows a dimensional view of another embodiment of a conduit assembly.

FIG. 46 shows a dimensional view of the connection sleeve of FIG. 45.

FIG. 47 shows a dimensional view of one end of conduit assembly of FIG. 45.

FIG. 48 shows a dimensional view of an anchor end of the present invention.

FIG. 49 shows a lateral cross-sectional view of an anchor end.

FIG. 50 shows a horizontal cross-sectional view of an anchor end taken along line XXI.

FIG. 51 illustrates a dimensional view of the rotating frame of FIG. 35.

FIG. 52 is an enlarged view of a holder for an external conduit.

FIG. 53 shows an alternative embodiment of the bowl with the cross-section taken similarly to that shown in FIG. 38.

FIG. 54 shows an alternative embodiment of the top core.

FIG. 55 shows an alternative embodiment of the connection sleeve.

### **Modes for Carrying Out The Invention**

[0010] Features of the present invention are embodied in the permanent blood driving equipment, the disposable photopheresis kit, the various devices which make up the disposable kit, and the corresponding treatment process. The following written description is outlined as follows:

- I. Disposable Photopheresis Kit
  - A. Cassette for Controlling Fluid Flow
    1. Filter Assembly
  - B. Irradiation Chamber
  - C. Centrifuge Bowl
    1. Drive Tube
- II. Permanent Tower System
  - A. Photoactivation Chamber
  - B. Centrifuge Chamber
  - C. Fluid Flow Control Deck
    1. Cassette Clamping Mechanism
    2. Self-Loading Peristaltic Pumps
  - D. Infra-Red Communication
- III. Photopheresis Treatment Process

[0011] The above-outline is included to facilitate understanding of the features of the present invention. The outline is not limiting of the present invention and is not intended to categorize or limit any aspect of the invention. The inventions are described and illustrated in sufficient detail that those skilled in this art can readily make and use them. However, various alternatives, modifications, and improvements should become readily apparent without departing from the spirit and scope of the invention. Specifically, while the invention is described in the context of a disposable kit and permanent blood drive system for use in photopheresis therapy, certain aspects of the invention are not so limited and are applicable to kits and systems used for rendering other therapies, such as apheresis or any other extracorporeal blood treatment therapy.

#### I. Disposable Photopheresis Kit

[0012] FIG. 1 illustrates disposable photopheresis kit **1000** embodying features of the present invention. It is necessary that a new disposable sterile kit be used for each therapy session. In order to facilitate the circulation of fluids through photopheresis kit **1000**, and to treat blood fluids circulating therethrough, photopheresis kit **1000** is installed in permanent tower system **2000** (FIG. 17). The installation of photopheresis kit **1000** into tower system **2000** is described in detail below.

[0013] Photopheresis kit **1000** comprises cassette **1100**, centrifuge bowl **10**, irradiation chamber **700**, hematocrit sensor **1125**, removable data card **1195**, treatment bag **50**, and plasma collection bag **51**. Photopheresis kit **1000** further comprises saline connector spike **1190** and anticoagulant connector spike **1191** for respectively connecting saline and anticoagulant fluid bags (not shown). Photopheresis kit **1000** has all the necessary tubing and connectors to fluidly connect all devices and to route the circulation of fluids during a photopheresis treatment session. All tubing is sterile medical grade flexible tubing. Triport connectors **1192** are provided at various positions for the introduction of fluids into the tubing if necessary.

[0014] Needle adapters **1193** and **1194** are provided for respectively connecting photopheresis kit **1000** to needles for drawing whole blood from a patient and returning blood fluids to the patient. Alternatively, photopheresis kit **1000** can be adapted to use a single needle to both draw whole blood from the patient and return blood fluids to the patient. However, a two needle kit is preferred because of the ability to simultaneously draw whole



blood and return blood fluids to the patient. When a patient is hooked up to photopheresis kit **1000**, a closed loop system is formed.

[0015] Cassette **1100** acts both as a tube organizer and a fluid flow router. Irradiation chamber **700** is used to expose blood fluids to UV light. Centrifuge bowl **10** separates whole blood into its different components according to density. Treatment bag **50** is a 1000mL three port bag. Straight bond port **52** is used to inject a photoactivatable or photosensitive compound into treatment bag **50**. Plasma collection bag **51** is 1000mL two port bag. Both treatment bag **50** and plasma collection bag **51** have a hinged cap spike tube **53** which can be used for drainage if necessary. Photopheresis kit **1000** further comprises hydrophobic filters **1555** and **1556** which are adapted to connect to pressure transducers **1550** and **1551** to filter **1500** via vent tubes **1552** and **1553** for monitoring and controlling the pressures within tubes connecting the patient (FIG. 10). Monitoring the pressure helps ensure that the kit is operating within safe pressure limits. The individual devices of photopheresis kit **1000**, and their functioning, are discussed below in detail.

#### A. Cassette for Controlling Fluid Flow

[0016] FIG. 2 shows a top perspective view of a disposable cassette **1100** for valving, pumping, and controlling the movement of blood fluids during a photopheresis treatment session. Cassette **1100** has housing **1101** that forms an internal space that acts as a casing for its various internal components and tubular circuitry. Housing **1101** is preferably made of hard plastic, but can be made of any suitably rigid material. Housing **1101** has side wall **1104** and top surface **1105**. Side wall **1104** of housing **1101** has tabs **1102** and **1103** extending therefrom. During a photopheresis treatment, cassette **1100** needs to be secured to deck **1200** of tower system **2000**, as is best illustrated in FIG. 25. Tabs **1102** and **1103** help position and secure cassette **1100** to deck **1200**.

[0017] Cassette **1100** has fluid inlet tubes **1106**, **1107**, **1108**, **1109**, **1110**, **1111**, and **1112** for receiving fluids into cassette **1100**, fluid outlet tubes **1114**, **1115**, **1116**, **1117**, **1118**, and **1119** for expelling fluids from cassette **1100**, and fluid inlet/outlet tube **1113** that can be used for both introducing and expelling fluids into and out of cassette **1100**. These fluid input and output tubes fluidly couple cassette **1100** to a patient being treated, as well as the various devices of photopheresis kit **1000**, such as centrifuge bowl **10**, irradiation chamber **700**, treatment bag **50**, plasma collection bag **51**, and bags containing saline, anticoagulation fluid to form a closed-loop extracorporeal fluid circuit (FIG. 27).

[0018] Pump tube loops **1120**, **1121**, **1122**, **1123**, and **1124** protrude from side wall **1104** of housing **1101**. Pump tube loops **1120**, **1121**, **1122**, **1123**, and **1124** are provided for facilitating the circulation of fluids throughout photopheresis kit **1000** during therapy. More specifically, when cassette **1100** is secured to deck **1200** for operation, each one of said pump tube loops **1120**, **1121**, **1122**, **1123**, and **1124** are loaded into a corresponding peristaltic pump **1301**, **1302**, **1303**, **1304**, and **1305** (FIG. 4). Peristaltic pumps **1301**, **1302**, **1303**, **1304**, and **1305** drive fluid through the respective pump tube loops **1120**, **1121**, **1122**, **1123**, and **1124** in a predetermined direction, thereby driving fluid through photopheresis kit **1000** (FIG. 1) as necessary. The operation and automatic loading and unloading of peristaltic pumps **1301**, **1302**, **1303**, **1304**, and **1305** is discussed in detail below with respect to FIGS. 28-33.

[0019] Turning now to FIG. 3, cassette **1100** is shown with housing **1101** in an exploded state. For ease of illustration and description, the internal tubular circuitry within housing **1101** is not illustrated in FIG. 3. The internal tubular circuitry is illustrated in FIG. 4 and will be discussed in relation thereto. Cassette **1100** has filter assembly **1500** positioned therein and in fluid connection with inlet tube **1106**, outlet tube **1114**, and one end of each of pump tube loops **1120** and **1121**. Filter assembly **1500** comprises vent chambers **1540** and **1542**. Filter assembly **1500**, and its functioning, is discussed in detail below with respect to FIGS. 6-10.

[0020] Housing **1101** comprises cover **1130** and base **1131**. Cover **1130** has top surface **1105**, a bottom surface **1160** (FIG. 5), and side wall **1104**. Cover **1130** has openings **1132** and **1133** for allowing vent chambers **1540** and **1542** of filter assembly **1500** to extend therethrough. Side wall **1104** has a plurality of tube slots **1134** to allow the inlet tubes, outlet tubes, and pump loop tubes to pass into the internal space of housing **1101** for connection with the internal tubular circuitry located therein. Only a few tube slots **1134** are labeled in FIG. 3 to avoid numerical crowding. Tabs **1102** and **1103** are positioned on side wall **1104** so as not to interfere with tube slots **1134**. Cover **1130** has occlusion bars **1162** and **1162A** extending from bottom surface **1160** (FIG. 5). Occlusion bars **1162** and **1162A** are preferably molded into bottom surface **1160** of cover **1130** during its formation.

[0021] Base **1131** has a plurality of U-shaped tube-holders **1135** extending upward from top surface **1136**. U-shaped tube holders **1135** hold the inlet tubes, outlet tubes, pump loop tubes, filter assembly, and internal tubular circuitry in place. Only a few U-shaped holders **1135** are labeled in FIG. 3 to avoid numerical crowding. Preferably, a U-shaped holder **1135** is provided on base **1131** at each location where an inlet tube, an outlet tube, or a pump loop

tube passes through a tube slot **1134** on side wall **1104**. Male extrusions **1136** protrude from top surface **1136** of base **1131** for mating with corresponding female holes **1161** located on bottom surface **1160** of cover **1130** (FIG. 5). Preferably, a male protrusion **1136** is located at or near each of the four corners of base **1130** and near filter **1500**. Male protrusions **1136** mate with the female holes **1161** to form a snap-fit and secure base **1131** to cover **1130**.

[0022] Base **1131** further comprises a hub **1140**. Hub **1140** is a five-way tube connector used to connect five tubes of the internal tubular circuitry. Preferably, three apertures **1137** are located near and surround three of the tubes leading into hub **1140**. Hub **1140** acts as a centralized junction which can be used, in conjunction with compression actuators **1240-1247** (FIG. 22), to direct fluids through photopheresis kit **1000** and to and from the patient. In addition to hub **1140**, appropriate tube connectors, such as T-connectors **1141** and Y-connector **1142**, are used to obtain the desired flexible tubing pathways.

[0023] Five apertures **1137** are located on the floor of base **1130**. Each aperture **1137** is surrounded by an aperture wall **1138** having slots **1139** for passing portions of the internal tubular circuitry therethrough. An elongated aperture **1157** is also provided on the floor of base **1131**. Apertures **1137** are located on base **1131** to align with corresponding compression actuators **1243-1247** of deck **1200** (FIG. 22). Aperture **1157** is located on base **1131** to align with compression actuators **1240-1242** of deck **1200** (FIG. 22). Each aperture **1137** is sized so that a single compression actuator **1243-1247** can extend therethrough. Aperture **1157** is sized so that three compression actuators **1240-1242** can extend therethrough. Compression actuators **1240-1247** are used to close/occlude and open certain fluid passageways of the internal tubular circuitry in order to facilitate or prohibit fluid flow along a desired path. When it is desired to have a certain passageway open so that fluid can flow therethrough, the compression actuator **1240-1247** for that passageway is in a lowered position. However, when it is desired to have a certain fluid passageway closed so that fluid can not flow therethrough, the appropriate compression actuator **1240-1247** is raised, extending the compression actuator **1240-1247** through aperture **1137** or **1157** and compressing a portion of the flexible tubular circuitry against bottom surface **1160** (FIG. 5) of cover **1130**, thereby closing that passageway. Preferably, occlusion bars **1163** and **1173** (FIG. 5) are positioned on bottom surface **1160** to align with the compression actuators **1240-1247** so that the portion of flexible tubing being occluded is compressed against occlusion bar **1163** or **1173**. Alternatively, the occlusion bar can be omitted or located on the compression actuators themselves.

[0024] It is preferable for cassette **1100** to have a unique identifier that can communicate with and relay information to permanent tower system **2000**. The unique identifier is provided to ensure that the disposable photopheresis kit is compatible with the blood drive equipment into which it is being loaded, and that the photopheresis kit is capable of running the desired treatment process. The unique identifier can also be used as a means to ensure that the disposable photopheresis kit is of a certain brand name or make. In the illustrated example, the unique identifier is embodied as data card **1195** (FIG. 2) that is inserted into data card receiving port **2001** of permanent tower system **2000** (FIG. 17). Data card **1195** has both read and write capabilities and can store data relating to the treatment therapy performed for future analysis. The unique identifier can also take on a variety of forms, including, for example, a microchip that interacts with the blood drive equipment when the kit is loaded, a bar code, or a serial number.

[0025] Cover **1130** has data card holder **1134** for holding data card **1195** (FIG. 1). Data card holder **1134** comprises four elevated ridges in a segmented rectangular shape for receiving and holding data card **1195** to cassette **1100**. Data card holder **1134** holds data card **1195** in place via a snap-fit (FIG. 2).

[0026] Referring now to FIGS. 1 and 4, the internal tubular circuitry of cassette **1100** will now be discussed. At least a portion of the internal tubular circuitry is preferably made of flexible plastic tubing that can be pinched shut by the exertion of pressure without compromising the hermetic integrity of the tube. Base **1131** of cassette **1100** is illustrated in FIG. 4 so that the internal tubular circuitry can be viewed. Inlet tubes **1107** and **1108** and outlet tube **1115** are provided for coupling cassette **1100** to centrifuge bowl **10** (FIG. 1). More specifically, outlet tube **1115** is provide for delivering whole blood from cassette **1100** to centrifuge bowl **10**, and inlet tubes **1107** and **1108** are respectively provide for returning a lower density blood components and higher density blood components to cassette **1100** for further routing through photopheresis kit **1000**. The lower density blood components can include, for example, plasma, leukocytes, platelets, buffy coat, or any combination thereof. The higher density components can include, for example, red blood cells. Outlet tube **1117** and inlet tube **1112** fluidly couple cassette **1100** to irradiation chamber **700**. More specifically, outlet tube **1117** is provided for delivering an untreated lower density blood component, for example buffy coat, to irradiation chamber **700** for exposure to photo energy, while inlet tube **1112** is provided for returning the treated lower density blood component to cassette **1100** for further routing.

[0027] Inlet tube **1111** and outlet tube **1116** couple treatment bag **50** to cassette **1100**. Outlet tube **1116** is provided to deliver an untreated low density blood component, for example buffy coat, to treatment bag **50**. Outlet tube **1116** has hematocrit (“HCT”) sensor **1125** operably connected thereto to monitor for the introduction of a high density blood component, such as red blood cells. HCT sensor **1125** is a photo sensor assembly and is operably coupled to a controller. HCT sensor **1125** sends a detection signal to the controller when red blood cells are detected in outlet tube **1116** and the controller will take the appropriate action. Inlet tube **1111** is provided to return the untreated low density blood component from treatment bag **50** to cassette **1100** for further routing. Inlet tubes **1109** and **1110** are respectively connected to a saline and anticoagulant storage bags (not shown) via spikes **1190** and **1191** and are provided for delivering saline and an anticoagulant fluid to cassette **1100** for further routing to the patient.

[0028] Inlet/Outlet tube **1113** and outlet tube **1118** couple plasma collection bag **50** to cassette **1100**. More specifically, outlet tube **1118** delivers a blood component, such as plasma, to plasma collection bag **51**. Inlet/Outlet tube **1113** can be used to either deliver red blood cells to plasma collection bag **51** from cassette **1100** or return the blood component(s) that build up in plasma collection bag **51** to cassette **1100** for further routing. Inlet tube **1106** and outlet tubes **1119** and **1114** are coupled to a patient. Specifically, outlet tube **1114** is provided to return treated blood, saline, untreated blood components, treated blood components, and other fluids back to the patient. Inlet tube **1106** is provided for delivering untreated whole blood (and a predetermined amount of an anticoagulant fluid) from the patient to cassette **1100** for routing and treatment within photopheresis kit **1000**. Outlet tube **1119** is specifically provided for delivering an anticoagulant fluid to inlet tube **1106**. It is preferable that all tubing is disposable medical grade sterile tubing. Flexible plastic tubing is the most preferred.

[0029] Cassette **1100** has five pump tube loops **1120**, **1121**, **1122**, **1123**, and **1124** for driving blood fluids throughout cassette **1100** and photopheresis kit **1000**. More specifically, pump tube loop **1121** loads into whole blood pump **1301** and respectively drives whole blood in and out of cassette **1100** via inlet tube **1106** and outlet tube **1115**, passing through filter **1500** along the way. Pump loop tube **1120** loads into return pump **1302** and drives blood fluids through filter **1500** and back to the patient via outlet tube **1114**. Pump loop tube **1122** loads into red blood cell pump **1305** and draws red blood cells from centrifuge bowl **10** and drives them into cassette **1100** via inlet line **1108**. Pump loop tube **1123** loads into anticoagulant

pump **1304** and drives an anticoagulant fluid into cassette **1100** via inlet tube **1124** and out of cassette **1100** to via outlet tube **1119**, which connects with inlet tube **1106**. Pump loop tube **1124** loads into recirculation pump **1303** and drives blood fluids, such as plasma, through treatment bag **50** and irradiation chamber **700** from cassette **1100**.

[0030] Each of peristaltic pumps **1301-1305** are activated when necessary to perform the photopheresis treatment therapy according to an embodiment of the method of the present invention which is described below in relation to FIGS. 26-27. Peristaltic pumps **1301-1305** can be operated one at a time or in any combination. The pumps **1301-1305** work in conjunction with compression actuators **1240-1247** to direct fluids through desired pathways of photopheresis kit **1000**. Apertures **1137** and **1157** are strategically located on base **1131** along the internal tubular circuitry to facilitate proper routing. Through the use of compression actuators **1240-1247**, the fluids can be directed along any pathway or combination thereof.

#### 1. The Filter Assembly

[0031] Filter **1500**, which is located within cassette **1100** as described above, is illustrated in detail in FIGS. 6-10. Referring first to FIGS. 6 and 7, filter **1500** is illustrated fully assembled. Filter **1500** comprises a filter housing **1501**. Filter housing **1501** is preferably constructed of a transparent or translucent medical grade plastic. However, the invention is not so limited and filter housing **1501** can be constructed of any material that will not contaminate blood or other fluids that are flowing therethrough.

[0032] Filter housing **1501** has four fluid connection ports extruding therefrom, namely whole blood inlet port **1502**, whole blood outlet port **1503**, treated fluid inlet port **1504**, and treated fluid outlet port **1505**. Ports **1502-1505** are standard medical tubing connection ports that allow medical tubing to be fluidly connected thereto. Ports **1502-1505** respectively contain openings **1506**, **1507**, **1508** and **1509**. Openings **1506**, **1507**, **1508** and **1509** extend through ports **1502**, **1503**, **1504** and **1505**, forming fluid passageways into filter housing **1501** at the desired locations.

[0033] Ports **1502**, **1503**, **1504** and **1505** are also used to secure filter **1500** within cassette **1100**. In doing so, ports **1502**, **1503**, **1504** and **1505** can engage U-shaped fasteners **1135** of cassette **1100** (FIG. 3). Filter housing **1501** also has a protrusion **1510** extending the bottom surface of housing floor **1518**. Protrusion **1510** fits into a guide hole of base **1131** of cassette **1100** (FIG. 3).

[0034] Referring now to FIG. 8, filter **1500** is illustrated in an exploded state. Filter housing **1501** is a two-piece assembly comprising roof **1511** and base **1512**. Roof **1511** is connected to base **1512** by any means known in the art, such as ultrasonic welding, heat welding, applying an adhesive, or by designing roof **1511** and base **1512** so that a tight fit results between the two. While filter housing **1501** is illustrated as a two-piece assembly, filter housing **1501** can be either a single piece structure or a multi-piece assembly.

[0035] Base **1512** has chamber separation wall **1513** extending upward from a top surface of housing floor **1518** (FIG. 7). When base **1512** and roof **1511** are assembled, top surface **1515** of chamber separation wall **1513** contacts the bottom surface of roof **1511**, forming two chambers within the filter housing, whole blood chamber **1516** and filter chamber **1517**. Fluid can not directly pass between whole blood chamber **1516** and filter chamber **1517**.

[0036] Whole blood chamber **1516** is a substantially L-shaped chamber having floor **1514**. Whole blood chamber **1516** has a whole blood inlet hole **1519** and a whole blood outlet hole (not illustrated) in floor **1514**. Whole blood inlet hole **1519** and the whole blood outlet hole are located at or near the ends of the substantially L-shaped whole blood chamber **1516**. Whole blood inlet hole **1519** forms a passageway with opening **1506** of inlet port **1502** so that a fluid can flow into whole blood chamber **1516**. Similarly, the whole blood outlet hole (not illustrated) forms a passageway with opening **1507** of outlet port **1503** so that fluid can flow out of whole blood chamber **1516**.

[0037] Filter chamber **1517** has floor **1520**. Floor **1520** has elevated ridge **1521** extending upward therefrom. Elevated ridge **1521** is rectangular and forms a perimeter. While elevated ridge **1521** is rectangular in the illustrated embodiment, elevated ridge **1521** can be any shape so long as it forms an enclosed perimeter. The height of elevated ridge **1521** is less than the height of chamber separation wall **1513**. As such, when roof **1511** and base **1512** are assembled, space exists between the top of elevated ridge **1521** and the bottom surface of roof **1511**. Elevated ridge **1521** and chamber separation wall **1513** form a trench **1524** there between.

[0038] In order to facilitate fluid flow through filter chamber **1517**, floor **1520** of filter chamber **1517** has treated fluid inlet hole **1522** and treated fluid outlet hole **1523**. Treated fluid inlet hole **1522** is located exterior of the perimeter formed by elevated ridge **1521** and forms a passageway with opening **1508** of inlet port **1504** so that a fluid can flow into filter chamber **1517** from outside filter housing **1501**. Treated fluid outlet hole **1523** is located

interior of the perimeter formed by elevated ridge **1521** and forms a passageway with opening **1509** of outlet port **1505** so that a fluid can flow out of filter chamber **1517**.

[0039] Filter **1500** further comprises filter element **1530**. Filter element **1530** comprises frame **1531** having filter media **1532** positioned therein. Frame **1531** has a neck **1534** that forms a filter inlet hole **1533**. Filter element **1530** is positioned in filter chamber **1517** so that frame **1531** fits into trench **1524** and neck **1534** surrounds treated blood inlet hole **1522**. Filter inlet hole **1533** is aligned with treated fluid inlet hole **1522** so that incoming fluid can freely flow through holes **1522** and **1533** into filter chamber **1517**. Frame **1531** of filter element **1530** forms a hermetic fit with elevated ridge **1521**. All fluid that enters filter chamber **1517** through holes **1522** and **1533** must pass through filter media **1532** in order to exit filter chamber **1517** via treated fluid outlet hole **1523**. Filter media **1532** preferably has a pore size of approximately 200 microns. Filter media **1532** can be formed of woven mesh, such as woven polyester.

[0040] Filter chamber **1517** further comprises filter vent chamber **1540** within roof **1511**. Filter vent chamber **1540** has gas vent **1541** in the form of a hole (FIG. 9). Because gas vent **1541** opens into filter vent chamber **1540** which in turn opens into filter chamber **1517**, gases that build-up within filter chamber **1517** can escape through gas vent **1541**. Similarly, whole blood chamber **1516** comprises blood vent chamber **1542** within roof **1511**. Blood vent chamber **1542** has gas vent **1543** in the form of a hole. Because gas vent **1543** opens into blood vent chamber **1542** which in turn opens into whole blood chamber **1517**, gases that build-up in whole blood chamber **1516** can escape via gas vent **1543**.

[0041] FIG. 10 is a top view of filter **1500** having pressure sensors **1550** and **1551** connected to gas vents **1541** and **1543**. Pressure sensors **1550** and **1551** are preferably pressure transducers. Pressure sensor **1550** is connected to gas vent **1541** via vent tubing **1552**. Vent tubing **1552** fits into gas vent **1541** so as to form a tight fit and seal. Because gas vent **1541** opens into filter vent chamber **1540** which in turn opens into filter chamber **1517**, the pressure in vent tubing **1552** is the same as in filter chamber **1517**. By measuring the pressure in vent tubing **1552**, pressure sensor **1550** also measures the pressure within filter chamber **1517**. Similarly, pressure sensor **1551** is connected to gas vent **1543** via vent tubing **1553**. Vent tubing **1553** fits into gas vent **1543** so as to form a tight fit and seal and pressure sensor **1551** measures the pressure within whole blood chamber **1516**. Filter vent chamber **1540** and blood vent chamber **1542** extend through openings **1132** and **1133** of cassette **1100** when filter **1500** is positioned therein (FIG. 2). This allows the pressure within chambers



**1516** and **1517** to be monitored while still protecting filter chamber **1500** and the fluid connections thereto.

[0042] Pressure sensors **1550** and **1551** are coupled to controller **1554**, which is a properly programmed processor. Controller **1554** can be a main processor used to drive the entire system or can be a separate processor coupled to a main processor. Pressure sensors **1550** and **1551** produce electrical output signals representative of the pressure readings within chambers **1517** and **1516** respectively. Controller **1554** receives on a frequent or continuous basis data representing the pressure within chambers **1516** and **1517**. Controller **1554** is programmed with values representing desired pressures within chambers **1516** and **1517**. Controller **1554** continuously analyzes the pressure data it receives from pressure sensors **1550** and **1551** to determine whether the pressure readings are within a predetermined range from the desired pressure for chambers **1517** and **1516**. Controller **1554** is also coupled to whole blood pump **1301** and return pump **1302**. In response to the pressure data received from pressure sensors **1551** and **1550**, controller **1554** is programmed to control the speed of whole blood pump **1301** and return pump **1302**, thereby adjusting the flow rates through the pumps **1301** and **1301**. Adjusting these flow rates in turn adjust the pressure within whole blood chambers **1516** and filter chamber **1517** respectively. It is in this way that the pressure within the lines drawing and returning blood to and from the patient is maintained at acceptable levels.

[0043] The functioning of filter **1500** during a photopheresis therapy session will now be discussed in relation to FIGS. 1, 6, and 10. While the functioning of filter **1500** will be described in detail with respect to drawing whole blood from a patient and returning a component of said whole blood back into the patient after it is treated, the invention is not so limited. Filter **1500** can be used in connection with almost any fluid, including red blood cells, white blood cells, buffy coat, plasma, or a combination thereof.

[0044] Whole blood pump **1601** draws whole blood from a patient who is connected to photopheresis kit **1000** via a needle connected to port **1193**. The rotational speed of whole blood pump is set so that the pressure of the line drawing the whole blood from the patient is at an acceptable level. Upon being drawn from the patient, the whole blood passes into cassette **1100** via inlet tube **1106**. Inlet tube **1106** is fluidly connected to inlet port **1502** of filter **1500**. The whole blood passes through opening **1506** of inlet port **1502** and into L-shaped whole blood chamber **1516**. The whole blood enters chamber **1516** through inlet hole **1519** which is located on floor **1514**. As more whole blood enters chamber **1516**, the whole

blood spills along floor **1514** until it reaches the whole blood outlet hole (not illustrated) at the other end of L-shaped whole blood chamber **1516**. As discussed above, the whole blood outlet whole forms a passageway with opening **1507** of outlet port **1503**. The whole blood that is within chamber **1516** flows across floor **1514**, through the whole blood outlet hole, into outlet port **1503**, and out of filter **1500** through opening **1507**.

[0045] As the whole blood passes through whole blood chamber **1516**, gases that are trapped in the whole blood escape. These gases collect in blood vent chamber **1542** and then escape via gas vent **1543**. Pressure sensor **1551** continuously monitors the pressure within blood chamber **1516** through vent tube **1553** and transmits corresponding pressure data to controller **1554**. Controller **1554** analyzes the received pressure data and if necessary adjusts the speed of whole blood pump **1301**, thereby adjusting the flow rate and pressure within chamber **1516** and inlet tube **1106**. Controller **1554** adjust the pump speed to ensure that the pressure is within the desired pressure range.

[0046] The whole blood then exits filter **1500** through outlet port **1503** and passes out of cassette **1100** via outlet tube **1115**. The whole blood is then separated into components and/or treated as described in detail below. Before being returned to the patient, this treated fluid (i.e. treated blood or blood components) must be filtered. Untreated fluids such as red blood cells also must be filtered and will subjected to the below filtering process. The treated fluid is fed into filter chamber **1517** through opening **1508** of inlet port **1504**. Inlet port **1504** is fluidly connected to pump loop tube **1120**. The treated fluid enters filter chamber **1517** through inlet hole **1522** and passes through filter inlet hole **1533** of filter element **1530**. The treated fluid fills filter chamber **1517** until it spills over frame **1531** of filter element **1530**, which is secured to elevated ridge **1521**. The treated fluid passes through filter media **1532**. Filter media **1532** removes contaminants and other undesired materials from the treated fluid while at the same facilitating the release of trapped gases from the treated fluid. The treated fluid that passes through filter media **1532** gathers on floor **1520** of filter chamber **1517** within the perimeter formed by elevated ridge **1521**. This treated fluid then passes into treated fluid outlet hole **1523** and out of filter **1500** through opening **1506** of outlet port **1502**. The treated fluid is then returned to the patient via outlet tube **1114**, which is fluidly connected to outlet port **1502**. The treated fluid is driven through filter chamber **1517** and outlet tube **1114** by return pump **1302**.

[0047] Gases that are trapped in the treated fluid escape and collect in filter vent chamber **1540** as the treated fluid flows through filter chamber **1517**. These gases then escape filter

**1500** via gas vent **1541**. Pressure sensor **1550** continuously monitors the pressure within filter chamber **1517** through vent tube **1552** and transmits corresponding pressure data to controller **1554**. Controller **1554** analyzes the received pressure data and compares it to the desired pressure value and range. If necessary, controller **1554** adjusts the speed of return pump **1302**, thereby adjusting the flow rate and pressure within chamber **1517** and outlet tube **1114**.

#### B. Irradiation Chamber

[0048] FIGS. 11-16 illustrate irradiation chamber **700** of photopheresis kit **1000** in detail. Referring first to Fig. 11, irradiation chamber **700** is formed by joining two plates, a front and a back plate having a thickness of preferably about 0.06 in. to about 0.2 in., which are preferably comprised of a material ideally transparent to the wavelength of electromagnetic radiation. In the case of ultraviolet A radiation, polycarbonate has been found most preferred although other materials such as acrylic may be employed. Similarly, many known methods of bonding may be employed and need not be expanded on here.

[0049] The first plate **702** has a first surface **712** and a second surface **714**. In a preferred embodiment the first plate **702** has a first port **705** on a first surface **712**, in fluid communications with the second surface **714**. The second surface **714** of the first plate **702** has a raised boundary **726A** defining an enclosure. The boundary **726A** preferably extends substantially perpendicular from the second surface **714** (i.e. about 80-100 degrees). Extending from the second surface **714** (preferably substantially perpendicularly) are raised partitions **720A**. The boundary **726A** surrounds the partitions **720A**. One end of each partition **720A** extends and contacts the boundary **726A**.

[0050] The second plate **701** has a first surface **711** and a second surface **713**. In a preferred embodiment the second plate **701** preferably has a second port **730** on a first surface **711**, in fluid communications with the second surface **713**. The second surface **713** of the back plate **701** has a raised boundary **726B** defining an enclosure. The boundary **726B** preferably extends substantially perpendicular from the second surface **713** (i.e. about 80-100 degrees). Extending from the second surface **713** (preferably substantially perpendicular) are raised partitions (**720B**). The boundary **726B** surrounds the partitions **720B**. One end of each partition **720A** extends and contacts one side of boundary (**726B**).

[0051] The joining of the second surfaces of the first and second plates results in a fluid tight junction between boundaries **726A** and **726B** thereby forming boundary **726**. Partitions **720A**

and **720B** are also joined forming a fluid tight junction thereby forming partition **720**. The boundary **726** forms an irradiation chamber **700** and together with the partitions **720** provides a pathway **710** having channels **715** for conducting fluid. The pathway maybe serpentine, zig-zag, or dove-tailed. Currently preferred is a serpentine pathway.

[0052] With reference to FIG. 11 and 12, irradiation chamber **700** comprises a serpentine pathway **710** for conducting patient fluid, such as buffy coat or white blood cells, from inlet port **705** to outlet port **730**, i.e., the serpentine pathway **710** is in fluid communication with inlet port **705** of front plate **702** and outlet port **730** of back plate **701**. Patient fluid is supplied from cassette **1100** to inlet port **705** via outlet tube **1117**. After photoactivation and passing through serpentine pathway **710**, the treated patient fluid is returned to cassette **1100** via inlet tube **1112** (FIGS. 1 and 4). The patient fluid is driven by recirculation pump **1303**. Self-shielding effects of the cells is reduced while the cells are photoactivated by irradiation impinging upon both sides of irradiation chamber **700**.

[0053] Figure 11 shows pin **740** and recess **735** which align the two plates of irradiation chamber prior to being joined together in a sealing arrangement by RF welding, heat impulse welding, solvent welding or adhesive bonding. Joining of the plates by adhesive bonding and RF welding is more preferred. Joining of the front and back plates by RF welding is most preferred as the design of the raised partitions **720** and perimeter **725** minimizes flashing and allows for even application of RF energy. Locations of pin **740** and recess **735** may be inside serpentine pathway **710** or outside of serpentine pathway **710**. Figure 2 also shows a view of an irradiation chamber with axis L. Rotation of chamber **700** 180 degree about axis L gives the original configuration of the irradiation chamber. The irradiation chamber of the present invention has  $C_2$  symmetry about axis L.

[0054] Referring to FIGS. 11, 13, and 16, the leukocyte enriched blood, plasma, and priming solution are delivered through inlet port **705** of front plate **702** of irradiation chamber **700** into channel **715**. The channel **715** in the irradiation chamber **700** is relatively "thin" (e.g. on the order of approximately 0.04" as distance between two plates) in order to present large surface area of leukocyte rich blood to irradiation and reduce the self-shielding effects encountered with lower surface area/volume ratios. The cross section shape of channel **715** is substantially rectangular (e.g. rectangular, rhomboidal or trapezoidal) which has as its long side the distance between partition **720** and the distance between the plates as its short side. The shape of the cross section is designed for optimal irradiation of cells passing through

channel 715. While a serpentine pathway 710 is preferred in order to avoid or minimize stagnant areas of flow, other arrangements are contemplated.

[0055] The irradiation chamber 700 allows efficient activation of photoactivatable agents by irradiation from a light array assembly, such as the PHOTASETTE<sup>®</sup>'s two banks of UVA lamps (758) for activation (Figure 16). The irradiation plate and UVA light assembly (759) are designed to be used in a setting where edge 706 is oriented downward and edge 707 points upward. In this orientation, fluids entering input port 705 can exit from outlet port 730 with the aid of gravity. In the most preferred embodiment, irradiation of both sides of the irradiation chamber takes place concurrently while still permitting facile removal of the chamber. UVA light assembly 759 is located within UV chamber 750 of permanent tower system 2000 (FIGS. 17 and 18).

[0056] The irradiation chamber's fluid pathway loops to form two or more channels in which the leukocyte-enriched blood is circulated during photoactivation by UVA light. Preferably, irradiation chamber 700 has between 4 to 12 channels. More preferably, the irradiation chamber has 6 to 8 channels. Most preferably, the irradiation chamber has 8 channels.

[0057] Figure 14 shows cut-away views of the irradiation chamber. The channels 715 of serpentine pathway 710 are formed by the joining of raised partition 720 and perimeter 726 of the plates.

[0058] The irradiation chamber of the present invention can be made from a biocompatible material and can be sterilized by known methods such as heating, radiation exposure or treatment with ethylene oxide (ETO).

[0059] The method of irradiating cells using irradiation chamber 700 during extracorporeal treatment of cells with electromagnetic radiation (UVA) to be used in the treatment of a patient (such as to induce apoptosis in the cells and administer the cells into the patient) will now be discussed. Preferably the cells treated will be white cells.

[0060] In one embodiment of this method, a photoactivatable or photosensitive compound is first administered to at least a portion of the blood of a recipient prior to the extracorporeal treatment of the cells. The photoactivatable or photosensitive compound may be administered *in vivo* (e.g., orally or intravenously). The photosensitive compound, when administered *in vivo* may be administered orally, but also may be administered intravenously and/or by other conventional administration routes. The oral dosage of the photosensitive compound may be in the range of about 0.3 to about 0.7 mg/kg., more specifically, about 0.6 mg/kg.

**[0061]** When administered orally, the photosensitive compound may be administered at least about one hour prior to the photopheresis treatment and no more than about three hours prior to the photopheresis treatment. If administered intravenously, the times would be shorter. Alternatively, the photosensitive compound may be administered prior to or contemporaneously with exposure to ultraviolet light. The photosensitive compound may be administered to whole blood or a fraction thereof provided that the target blood cells or blood components receive the photosensitive compound. A portion of the blood could first be processed using known methods to substantially remove the erythrocytes and the photoactive compound may then be administered to the resulting enriched leukocyte fraction. In one embodiment, the blood cells comprise white blood cells, specifically, T-cells.

**[0062]** The photoactivatable or photosensitive compound may, in the case of some psoralens, be capable of binding to nucleic acids upon activation by exposure to electromagnetic radiation of a prescribed spectrum, *e.g.*, ultraviolet light.

**[0063]** Photoactive compounds may include, but are not limited to, compounds known as psoralens (or furocoumarins) as well as psoralen derivatives such as those described in, for example, U.S. Pat. No. 4,321,919 and U.S. Pat. No. 5,399,719. The photoactivatable or photosensitive compounds that may be used in accordance with the present invention include, but are not limited to, psoralen and psoralen derivatives; 8-methoxypsoralen; 4,5,8-trimethylpsoralen; 5-methoxypsoralen; 4-methylpsoralen; 4,4-dimethylpsoralen; 4,5'-dimethylpsoralen; 4'-aminomethyl-4,5',8-trimethylpsoralen; 4'-hydroxymethyl-4,5',8-trimethylpsoralen; 4',8-methoxypsoralen; and a 4'-(omega-amino-2-oxa) alkyl-4,5',8-trimethylpsoralen, including but not limited to 4'-(4-amino-2-oxa)butyl-4,5',8-trimethylpsoralen. In one embodiment, the photosensitive compound that may be used comprises the psoralen derivative, amotosalen (S-59) (Cerus, Corp., Concord, CA). *See, e.g.*, U.S. Patent Nos. 6,552,286; 6,469,052; and 6,420,570. In another embodiment, the photosensitive compound that may be used in accordance with the invention comprises 8-methoxypsoralen.

**[0064]** Methoxsalen is a naturally occurring photoactive substance found in the seed of the *Ammi majus* (umbelliferae plant). It belongs to a class of compounds known as psoralens or furocoumarins. The chemical name is 9-methoxy-7H-furo[3,2-g][1]-benzopyran-7-one. The formulation of the drug is a sterile liquid at a concentration of 20 mcg/mL in a 10 mL vial. See <http://www.therakos.com/TherakosUS/pdf/uvadexpi.pdf>. Toxicology studies of

extracorporeal photopheresis and different dosages of UVADEX® and ultraviolet light in beagle dogs is located in the investigator's brochure.

[0065] Next, the portion of the subject's blood, recipient's blood, or the donor's blood to which the photoactive compound has been administered is treated by subjecting the portion of the blood to photopheresis using ultraviolet light. The photopheresis treatment may be carried out using long wavelength ultraviolet light (UVA) at a wavelength within the range of 320 to 400 nm. Such a range is not limiting, however, but is merely provided as an example. The exposure to ultraviolet light during the photopheresis treatment may have a duration of sufficient length to deliver, for example, about 1-2 J/cm<sup>2</sup> to the blood.

[0066] The photopheresis step is carried out *in vitro* by installing irradiation chamber 700 into photoactivation chamber 750 of permanent tower system 2000 (FIGS. 17 and 18). In one embodiment, when the photopheresis step is carried out *in vitro*, at least a fraction of the treated blood is returned to the subject, recipient, or donor. The treated blood or the treated enriched leukocyte fraction (as the case may be) may then be administered back to the subject, recipient, or donor.

[0067] The photopheresis process consists of three phases including: 1) the collection of a buffy-coat fraction (leukocyte-enriched), 2) irradiation of the collected buffy coat fraction, and 3) reinfusion of the treated white blood cells. This process will be discussed below in greater detail. Generally, whole blood is centrifuged and separated in centrifuge bowl 10. A total of approximately 240 ml of buffy coat and 300 ml of plasma are separated and saved for UVA irradiation.

[0068] The collected plasma and buffy coat are mixed with heparinized normal saline and UVADEX®. (water soluble 8-methoxypsoralin). This mixture flows in a 1.4 mm thick layer through the irradiation chamber of the present invention. The irradiation chamber 700, is inserted in photoactivation chamber 750 of tower system 2000 between two banks of UVA lamps of the PHOTSETTE® (FIG. 15). PHOTSETTE® UVA lamps irradiate both sides of this UVA-transparent irradiation chamber 700, permitting exposure to ultraviolet A light, yielding an average exposure per lymphocyte of 1-2 J/cm<sup>2</sup>. Following the photoactivation period, the cells are removed from the irradiation chamber 700.

[0069] In a preferred embodiment of the present invention the cells are removed by the action of gravity and any cells remaining in the chamber are displaced from the chamber with additional fluid selected from the group consisting of saline, plasma, and combinations thereof. For patients who are small such as children (e.g. under 30kg) or patients whose

vascular system is easily overloaded with fluids the amount of additional fluid used to was the irradiation chamber will preferably be not more than 2X the volume of the chamber, preferably not more than 1X the volume of the chamber, more preferably not more than 0.5X the volume of the chamber 0.25X the volume of the chamber. The treated cells volume is reinfused to the patient.

**[0070]** For a description of similar photopheresis systems and methods, *see* U.S. Patent Application No. 09/480,893, which is expressly incorporated herein by reference. Also useful herein are the methods and systems described in U.S. Patent Nos. 5,951,509; 5,985,914; 5,984,887, 4,464,166; 4,428,744; 4,398,906; 4,321,919; PCT Publication Nos. WO 97/36634; and WO 97/36581, all of which are entirely expressly incorporated herein by reference.

**[0071]** The effective amount of light energy that is delivered to the biological fluids may be determined using the methods and systems described in U.S. Patent No. 6,219,584, which is entirely expressly incorporated herein by reference. Indeed, the application of ECP to the various diseases described herein may require an adjustment of the amount of light energy to optimize the treatment process.

**[0072]** Furthermore, the photosensitizing agent used in the ECP process may be removed prior to returning the treated biological fluid to the patient. For example, Methoxsalen (UVADEX®) is utilized in the ECP process. Methoxsalen belong to a group of compounds known as psoralens. The exposure to methoxsalen or other psoralens may cause undesirable effects on the subject, recipient, or donor such as phototoxicity or other toxic effects associated with psoralen and their decomposition products. Therefore, the psoralen, psoralen derivatives, or psoralen decomposition products that may remain in the biological fluid may be removed after UV exposure. A process for the removal of psoralen biological fluids is described in U.S. Patent No. 6,228,995, which is entirely expressly incorporated herein by reference.

### C. Centrifuge Bowl

**[0073]** In a specific embodiment, the present invention relates to methods and apparatus that separate fluid components, such as, for example, the components of a biological fluid by density or weight. Biological fluids encompass fluids that comprise, exist in, or are used in, or delivered to living organisms. Indeed, biological fluids may comprise bodily fluids and their components, such as blood cells, plasma, and other fluids that comprise biological



components, including living organisms such as bacteria, cells, or other cellular components. Biological fluids may also comprise whole blood or specific whole blood components, including red blood cells, platelets, white blood cells, and precursor cells. In particular, it may be desirable to remove blood from a patient for treatment, such as for example, extracorporeal treatment. It is to be understood, however, that the present invention is adaptable to use with various centrifugal processing apparatus, and the specific example given herein is merely for illustrative purposes. Other uses for the separation techniques and apparatus may include other medical processes such as dialysis, chemotherapy, platelet separation and removal, and separation and removal of other specific cells. Additionally, the present invention may be used to separate other types of fluids that include a wide variety of non-medical uses, such as, for example, oil and fluid component separation. All components used in the present invention should not adversely affect biological fluids or render them unsuitable for their intended uses, such as those described herein and may be made of any suitable material compatible with uses described herein including, but not limited to plastics, such as polycarbonate, methyl methacrylate, styrene-acrylonitrile, acrylic, styrene, acrylonitrile or any other plastic. Where parts of the present invention are indicated to be attached together and form a fluid tight seal any appropriate conventional means of joining the parts may be used including but not limited to, adhesives, ultrasonic welding or RF welding.

[0074] The present invention has several advantages over centrifuges what use conventional Latham bowl. The Latham bowl in the UVAR<sup>®</sup> XTS<sup>™</sup> system has one inlet port that allows whole blood to come into the bowl and one outlet port that allows plasma and buffy coat to come out. Having only two ports limits the volume of buffy coat that can be collected per cycle. Each cycle involves filling the bowl with whole blood; 2) spinning the bowl to separate whole blood into plasma, buffy coat, and red blood cells; 3) collecting buffy coat for treatment, 4) bringing the bowl to rest; and 5) returning collected plasma and red blood cells. This buffy coat collection method may be characterized as being “batch-like” as the volume of buffy coat required for irradiation treatment can only be collected after several cycles of buffy coat collection. The limited volume of collected buffy coat per cycle results from the accumulated red blood cells remained inside the bowl. Thus the accumulated red blood cells that can only be emptied at the end of a buffy coat collection cycle is an inherent limitation of the Latham Bowl.

**[0075]** The bowl of the instant invention has three separate fluid conduits that can be used as an inlet port and two outlet ports. The additional fluid conduits allows for 1) reduce patient treatment time by having continuous spinning during the entire buffy coat collection process without having to stop spinning the bowl for removal of accumulated red blood cells; 2) treat small blood volume patients; by having collected red blood cells returned to patients continuously, these patients may be more amenable to medical treatments requiring the use of the buffy coat or fractions thereof such as extracorporeal photopheresis; 3) better separation of different components of fractions of cells within the buffy coat due to the increased spinning or rotation time and 4) the ability to separate high density red blood cells fractions from whole blood. This centrifuge bowl also provides the opportunity for reduced treatment time for any medical procedure requiring buffy coat fractions to be collected from patients that are substantially free of red blood cells, such as extra corporeal photopheresis.

**[0076]** To achieve the objects in accordance with the purpose of the present invention, as embodied and broadly described herein, FIGS. 35 and 36 depict specific embodiments of the present invention. The embodiment depicted in FIG. 35 comprises a centrifuge bowl **10A**, conduit assembly **860A**, frame **910A** and stationary restraint **918A**. The centrifuge bowl **10A** is in fluid communications with external conduit **20A** of conduit assembly **860A**. Lower sleeve end **832A** (FIG. 46) of connection sleeve **500A** is secured to bowl **10A**. Upper sleeve end **831A** of connection sleeve **500A** is secured to external conduit **20A**, connecting the external conduit **20A** to bowl **10A** and providing fluid communications from external conduit **20A** to bowl **10A**. The fluid communications enables fluid **800** to be supplied through external conduit **20A** to the bowl **10A**. Similarly this fluid communications also enables separated fluid components **810** and **820** to be removed from bowl **10A** through external conduit **20A**. Bowl **10A** and frame **910A** are adapted to be rotated around center axis **11A**.

**[0077]** Referring to FIG. 36, bowl **10A** comprises outer housing **100A**, connection sleeve **500A**, top core **200A**, bottom core **201A**, and housing floor **180A**. Outer housing **100A** may be constructed of any suitable biocompatible material as previously described for the purpose of the illustration in FIG. 36 the outer housing **100A** is constructed of clear plastic so that cores **200A** and **201A** are visible there through. Outer housing **100A** is attached to a housing floor **180A**, which in turn comprises protrusions **150A** for locking bowl **10A** into a rotational device such as rotational device **900A**. Bowl **10A** is preferably simplified in construction and is easy to manufacture by molding or other known manufacturing processes, such that it may be disposable or used for a limited number of treatments, and is most preferably capable of

containing about 125 ml of fluid, such fluid possibly being pressurized. In alternative embodiments, the volume capacity of the bowl may vary depending upon the health of the patient and his or her allowable extracorporeal volume. The volume capacity of the bowl may also vary depending upon the use of the bowl or the particular treatment for which the bowl is utilized. Additionally, to avoid contamination of biological fluids, or exposure of persons involved in the processing operation to the fluids, the transfer operations are preferably carried out within a sealed flow system, possibly pressurized, preferably formed of flexible plastic or similar material which can be disposed of after each use.

[0078] As is illustrated in FIGS. 36 and 37, the outer housing **100A** is substantially conical having an upper housing end **110A**, an outer housing wall **120A** and a lower housing end **190A**. Outer housing **100A** may be made of plastic (such as those plastics listed previously), or any other suitable material. Upper housing end **110A** has an outer surface **110B**, inner surface **110C** and housing outlet **700A** providing a passage between said surfaces. Preferably the upper housing will also have a neck **115A** formed about the housing outlet **700A**. The housing outlet **700A** and neck **115A** are sized to allow body **830A** of the connection sleeve **500A** to pass through while retaining sleeve flange **790A**, which extends from the body **830A** of connection sleeve **500A**. In one embodiment of the present invention an o-ring **791A** may be inserted between the sleeve flange **790A** and inner surface **110C** of the housing end **110A** to ensure a fluid tight seal is provided. In an alternative embodiment of the present invention illustrated in FIG 53, a second sleeve flange **790B** extends from the body **830A** of connection sleeve **500B** distal to the sleeve flange **790A**. Both sleeve flange **790A** and **790B** being adapted to fit within neck **115A** and retain o-ring **791A** therebetween. A fluid tight seal is provided in this embodiment by the o-ring contacting body **830A** and inner surface **110C** of the housing end **110A** adjacent to the neck **115A**. However, connection sleeve **500A** can be secured to bowl **10A** by any suitable means, including for example, a lip, groove, or tight fit and adhesive with a component of bowl **10A**. The outer housing wall joins the upper housing end **110A** and lower housing end **190A**. Lower housing end **190A** is attached to a housing floor **180A** of greater diameter than upper end **110A**. Housing floor **180A** is adapted to mate with the lower housing end **190A** and provide a fluid tight seal therewith. Any conventional means may be used to secure the lower housing end **190A** to the housing floor **180A**, including but not limited to, adhesives, ultrasonic welding or RF welding. Housing floor **180A** may have an indentation **185A** that is used to collect denser fluid **810**. The diameter of outer housing **100A** increases from upper housing end **110A** to lower housing end **190A**.

**[0079]** Outer housing **100A** is adapted to rotatably connect to a rotational device **900** (FIG. 35), such as for example, a rotor drive system or a rotating bracket **910**. The rotatable connection may, for example, be a bearing that allows free rotation of bowl **10A**. Outer housing **100A** preferably has a locking mechanism. The locking mechanism may be one or more protrusions **150A** designed to interact with corresponding indentations in a centrifuge container or any other suitable interconnect or locking mechanism or equivalent known in the art. The locking mechanism may also comprise a key slot **160** (FIG. 51).

**[0080]** Referring to FIG. 37, outer housing **100A** and the base **180A** define an interior volume **710A** in which cores **200A** and **201A** will fit when bowl **10A** is assembled. When fully assembled, cores **200A** and **201A** are fully within interior volume **710A** of outer housing **100A**, occupying a coaxial volume of interior volume **710A** about axis **11A**.

**[0081]** Referring to FIGS. 38, 40 and 44, the top core **200A** and bottom core **201A** are substantially conical and respectively have upper core ends **205A**, **206A**; outer core walls **210A**, **211A**; and lower core ends **295A**, **296A**. The cores **200A**, **201A** occupy coaxial volumes of interior volume **710A** of bowl **10A** and forming separation volume **220A** between upper end **205A** and outer wall **210A** of top core **200A** and outer wall **211A** and lower core end **296A** of bottom core **201A** and outer housing **100A**. Separation volume **220A** is that space of interior volume **710A** that is between cores **200A** and **201A** and outer housing **100A**.

**[0082]** As depicted in Figures 40 and 41 top core **200A** comprises upper core end **205A** and a lower core end **295A** that are joined by outer core wall **210A**. The outer core wall **210A** having an outer surface **210B** and inner wall surface **210C** and a lower edge **210D**. The diameter of top core **200A** preferably increases from upper core end **205A** to lower core end **295A**. Upper core end **205A** also comprises an outer surface **205B** and an inner surface **205C**. Centrally located about center axis and extending perpendicularly from the upper surface **205B** is lumen connector **481A**. Lumen connector **481A** has a top surface **482A** and a wall surface **482B**. Top surface **482A** has two passages **303B** and **325D** that provide fluid communications through the upper core end **205A** with second bowl channel **410A** and first bowl channel **420A** respectively. Second bowl channel **410A** is a conduit that has a conduit wall **325A** that extends perpendicularly from the inner surface **481C** of lumen connector **481A**.

**[0083]** As shown on FIGS. 39B, 39A and 40, second bowl channel **410** has fluid communication with conduit channel **760A** through conduit **321A** having a first end **321B** and a second end **321C** that is adapted to fit into passage **325D** of lumen connector **481A**. In

operation conduit channel **760A** of external conduit **20A** has fluid communication with bowl channel **410A**. First bowl channel **420A** is a second conduit that has a channel wall **401A** that extends substantially perpendicularly from inner surface **481C** of the lumen connector **481A**. As shown in FIGS. 39A, 39B and 40, first bowl channel **420A** has fluid communication with conduit channel **780A** of external conduit **20A** through hollow cylinder **322A** having a first end **322B** and a second end **322C** adapted to fit opening **303B** top surface **482A**. As is illustrated in one embodiment of the present invention, second bowl channel **410A** is disposed within first bowl channel **420A**. In an alternative embodiment of the present invention illustrated in FIG. 53, conduit wall **325A** may be composed of upper part **325F** and lower part **325G** and be fused with channel walls **401A** and **402A**.

[0084] Top surface **482A** also has indentation **483A** which provides fluid communications with chamber **740A**. When assembled, chamber **740A** is defined by lumen mounting recess **851A** less the volumes occupied by hollow cylinders **321A** and **322A** in the connection junction of connection sleeve **500A** and lumen connector **481A**. Chamber **740A** has fluid communication with conduit channel **770A** and with separation volume **220A** near neck **115A** through indentation **483A**. Thus indentation **483A** forms a passageway for the removal of second separated fluid component **820** through bowl chamber **740A**. Optionally present on the outer surface **205B** are a plurality of spacers **207A** which extend from the outer surface and contact the inner surface **110C** of the upper housing end **110A** to ensure fluid communications between the separation volume **220A** and the passageway formed by the indentations **483A**.

[0085] In an alternative embodiment illustrated in FIGS. 53, 54 and 55, conduits **321A** and **322A** may be affixed to openings **325D** and **303B** in the top surface **482A** of the lumen connector **481A**. Additionally, indentations **483A** may form a plurality channels in the lumen connector **481A** and be adapted to form chamber **740B** when connected to connection sleeve **500A** or **500B**. Chamber **740B** is adapted to have one or more surfaces **742A** that can mate with the male end **853A** of the connection sleeve **500A** (male end **853A** surrounds end **861** of external conduit **20A**). To facilitate the correct orientation of the connection sleeve **500A** to the lumen connector **481A** the shape of the male end **853A** and chamber **740B** may be nonsymmetrical or as is illustrated in FIGS 53, 54 and 55 a guide **855A** may be provided which extends from the top surface of the lumen connector **481A** and is adapted to fit within opening **857A** of the sleeve flange **790A**.

[0086] Referring back to Figures 40, the lower core end **295A** comprises an upper plate **299A** having a top surface **298A**, a bottom surface **297A**, and an edge **299B** that attaches and makes direct contact with lower edge **210D** of the outer core wall **210A**. The edge **299B** of the upper plate **299A** is adapted to be joined with lower edge **210D** of outer core wall **210A** and form a fluid tight seal therewith. Extending perpendicularly from the top surface **298A** of upper plate **299A** is a channel wall **402A**, having an upper end **402B** and a lower end **402C** and surrounds opening **303A** which is substantially in the center of upper plate **299A**. A number of fins **403A**, attached to the outside surface of channel wall **402A** and top surface **298A**, supports lumen wall **402A**. The channel wall **402A** is adapted to mate with channel wall **401A** forming a fluid tight seal and providing lumen **400A**. First bowl channel **420A** is in fluid communications with conduit channel **780A** of external conduit **20A** through conduit **322A**. Opening **303A** provides fluid communications from lumen **400A** to separation volume **220A** as will be further discussed. First bowl channel **420A** also surrounds second bowl channel **410A**.

[0087] Referring to Figures 43A, 43B and 44, bottom core **201A** comprises an upper core end **206A**, a outer core wall **211A** and a lower core end **296A**. The outer core wall **211A** having an outer surface **211B**, an inner wall **211C** and lower edge **211D**. The diameter of bottom core **201A** preferably increases from upper core end **206A** to lower core end **296A**. Bottom core **201A** also has a top surface **309A** and a bottom surface **309B**. Top surface **309A** has an indentation **186A** (preferably generally circular) substantial in the center of the surface **309A** of the upper core end **206A**. The indentation **186A** has an upper surface **186B** and an inner surface **186C**. The upper surface **186B** of the indentation **186A** has therein an opening **324D** which extends through to the inner surface **186C**. In an alternative embodiment of the present invention illustrated in FIG 53, the upper surface **186B**, may also have a recess **a186D** adapted to receive an o-ring and form a fluid type seal around the lower end of **325B** of conduit wall **325A**. Extending perpendicularly from inner surface **186C** around said opening **324D** is conduit wall **324A** having a distal end **324B**. On the top surface **309A** extending from the indentation **186A** to the outer surface **211B** of the outer core wall **211A** are one or more channels **305A**. The top surface **309A** may be horizontal or slope upward or downward from indentation **186A**. If top surface **309A** slopes upward or downward from indentation **186A** to core end **206A**, one skilled in the art would be able to adjust the shapes of upper plate **299A** and upper core end **295A** accordingly. Channels **305A** may have an even depth through out the length of the channel **305A**. However, channel

**305A** may slope downward or upward radially from the center. One skilled in the art would see that if top surface **309A** slopes upward or downward and channel **305A** has a constant depth, then channel **305A** slopes upward or downward accordingly.

[0088] Referring to Figures 38, the bottom surface **297A** of upper plate **299A** is in direct contact with the top surface area **309A** of bottom core **201A** when completely assembled. This contact forms a fluid tight seal between the two surface areas forming an opening **305B** from the indentation **186A** to channel **305A**. A second opening **305C** from channel **305A** is formed in the outer surface **211B** of outer core wall **211A**. The opening **305B** provides fluid communications from indentation **186A** through channel **305A** and opening **305C** to separation volume **220A** (FIGS. 38 and 40). Thus fluid **800** flows through conduit channel **780A** and subsequently passes through first bowl channel **420A**. From first bowl channel **420A**, fluid **800** then goes to through channel **305A** to the separation volume **220A**.

[0089] Referring to Figures 43A and 44, the lower core end **296A** has a lower plate **300A**, which has a top surface **300B**, a bottom surface **300C** and outer edge **300D**. Extending from the bottom surface **300C** of the lower plate **300** are one or more protrusions **301A**. The outer edge **300D** is adapted to be attached to the lower edge **211D** of the outer core wall **211A** and provide a fluid tight seal therewith. Positioned above housing floor **180A**, lower plate **300A** is circular and curves upward radially from its center (illustrated in FIG. 44). Alternatively, lower plate **300A** can be flat. As shown in FIG. 38 when positioned above housing floor **180A**, a volume **220C** exists between lower plate **300A** and housing floor **180A**. This volume **220C** is in fluid communication with separation volume **220A**. Lower plate **300A** may be made of plastic or any other suitable material. Additionally, extending substantially perpendicularly from the lower surface **300C** of lower plate **300A** is a conduit **320A**. Conduit **320A** has a first end **320B** that extends into the space **220C** between lower plate **300A** and housing floor **180A** and a second end **320C** that extends above the top surface **300B** of lower plate **300A**. The diameter of conduit **320A** is adapted to have a tight fit with conduit wall end **324B**. The volume inside conduit walls **324A** and **325A** comprises a lumen **400B**. The volume defined by lower plate **300A**, inner surface **211C**, and ceiling **253A** of bottom core **201A**, excluding second bowl channel **410A**, may comprise of air or a solid material (See FIGS. 43B and 44).

[0090] In an alternative embodiment of the present invention as illustrated in FIG. 53, support walls **405A** and **407A** may be optionally present. Support wall **405A** extends perpendicularly from bottom surface **309B**. Support wall **407A** extends perpendicularly from

the top surface **300B** of lower plate **300A** and connects with support wall **405A** when the bottom core **201A** is assembled. Conduit wall **324A** may be connected to conduit **320A** to form a fluid tight seal and conduits **324A**, **320A** may be fused respectively with supports walls **405A** and **407A**. Additionally present extending from the bottom surface **300C** of lower plate **300A** are one or more orientation spacers **409A** that mate within indentation **185A**.

[0091] As will be readily apparent to one of ordinary skill in the art, the bowl **10A** will need to be balanced about center axis **11A**. Accordingly, weights may be added as part of the device as is appropriate to facilitate the balancing of the bowl **10A** such as weight **408A** illustrated in FIG 53.

[0092] Referring to FIG. 38, bowl **10A** is adapted so that outer housing **100A**, cores **200A** and **201A**, lower plate **300A** and upper plate **299A**, housing floor **180A**, external conduits **20A** and connection sleeve **500A**, and lumens **400A** and **400B** are in connection and rotate together. Housing floor **180A** of outer housing **100A** comprises recesses **181A** on its top surface and these recesses are shaped to fit protrusion **301A** of lower plate **300A**. As shown, lower plate **300A** has round protrusion **301A** on its bottom surface **300C** to restrict movement of lower plate **300A** with respect to housing floor **180A**. When assembled, each single protrusion **301A** on the bottom surface of lower plate **300A** forms a tight fit with recess **181A** on housing floor **180A**. Thus, when outer housing **100A** is rotated, external conduit **20A** and connection sleeve **500A**, top core **200A**, upper plate **299A**, bottom core **201A**, lower plate **300A**, housing floor **180A**, and lumens **400A** and **400B** will rotate therewith.

[0093] As illustrated in FIG. 38 lumen **400A** allows whole blood **800** to come into bowl **10A** via a first bowl channel **420A**. First bowl channel **420A** provides a passageway for inflow of fluid **800** through lumen **400A** to indentation **186A** and then to the separation volume **220A** through channel **305A**. Lumen **400A** is located inside top core **200A**. Lumen **400A** has a height from upper lumen end **480A** and lower lumen end **402C**. Lumen **400A** is formed by the connection of channel wall **401A** extending from the inner surface **481C** of lumen connector **481A** and channel wall **402A** extending from the top surface **298A** of upper plate **299A**. Channel wall **401A** is supported by a plurality of fins **251A** which are attached to the inner wall surface **210C** of the outer core wall **210A** and inner surface **205C** of the upper core end **205A**, and channel wall **402A** is supported by a plurality of fins **403A** (FIG. 40). It can readily be seen that height of lumen **400A** can be adjusted by changing the sizes and shapes



of core 200A, channel wall 401A, channel wall 402A, conduit wall 325A, and the height of conduit wall 324A.

[0094] As illustrated in FIG. 38, lumen 400A, from upper lumen end 480A to lower lumen end 402C, encloses an inner lumen 400B. Lower lumen end 402C has an opening 303A which is in fluid communication with separation volume 220A through a number of channel 305A. In the illustrated embodiment lumen 400A comprises first bowl channel 420A. Second bowl channel 410A is located inside first bowl channel 420A of the top core 200A and is enclosed therein from lumen end 480A and to lumen 402C. Furthermore, second bowl channel 410A forms a passageway through lumen 400B from below lower plate 300A for the removal of a first separated fluid component 810 that gathers in indentation 185A of housing floor 180A. Second bowl channel 410A extends from housing floor 180A of outer housing 100A through lumen 400B and to conduit channel 760A of external conduit 20A.

[0095] Referring Figure 38 (shown without conduit 321C), inner lumen 400B allows red blood cells 810 to exit bowl 10A via a second bowl channel 410A that provides fluid communication from the housing floor above indentation 185A to opening 324E. Inner lumen 400B has an upper conduit end 325C and a lower conduit end 324B and comprises two conduit walls 324A and 325A which are connected in a fluid tight manner and form second bowl channel 410A that has a smaller diameter than and is separate and distinct from first bowl channel 420A. Conduit wall 325A is supported by a fin 251A that extends through channel wall 401A and attaches to conduit wall 325A. Unlike lumen 400A which has one end near indentation 186A, lumen 400B extends beyond indentation 186A and through bottom plate 300A. The first conduit wall 325A has an upper end 325C which has an opening 325D on the top surface 482A of lumen connector 481A and a lower end 325B having an opening 325E adapted to fit tightly with upper end 324C of conduit wall 324A. Upper end 324C of conduit wall 324A is higher than indentation 186A and has an opening 324D. Conduit wall 324A also has end lower end 324B and is supported by a plurality of fins 252A. Lower end 324B having opening 325E is adapted to connect to conduit 320A having opening 302A located near the center of lower plate 300A. The connection of openings 325E and 302A provide fluid communication between lumen 400B and the space 220C between lower plate 300A and housing floor 180A. The space 220C between lower plate 300A and housing floor 180A in turn has fluid communication with separation volume 220A.

[0096] Conduit **320A** provides a tight fit with lower end **324B**, providing support for second bowl channel **410A**. Each bowl channel **420A** and **410A** may be made of any type of flexible or rigid tubing (such as medical tubing) or other such device providing a sealed passageway, possibly for pressurized or unpressurized fluid flow, and which preferably can be disposable and sterilizable, i.e., of simple and efficient manufacture.

### 1. Drive Tube

[0097] As illustrated in FIGS. 39A and 39B, conduit assembly **860A** is attached to bowl **10A** via connection sleeve **500A** which is attached onto the first end **861A** of external conduit **20A** having a first conduit channel **780A**, a second conduit channel **760A**, and a third conduit channel **770A**. Each conduit channel has fluid communication with a first bowl channel **420A**, a second bowl channel **410A**, and a bowl chamber **740A**. The three conduit channels are equally spaced  $120^\circ$  apart and equal in diameter in external conduit **20A** (See FIG. 50). When fluidly connect to external conduit **20A** and bowl **10A**, conduit channel **780A** is fluidly connected with first bowl channel **420A** for inflowing fluid **800** from external conduit **20A** into bowl **10A** for separation. Similarly, second conduit channel **760A** fluidly connects to second bowl channel **410A** for removing first separated fluid component **810** from bowl **10A** into external conduit **20A**. Finally, third conduit channel **770A** connects to bowl chamber **740A** for removing second separated fluid component **820** from bowl **10A**.

[0098] As is illustrated in FIG. 45, external conduit **20A** has a connection sleeve **500A** on the first end **861A** and an anchor sleeve **870A** on the second end **862A** of external conduit **20A**. Optionally present between the connection sleeve **500A** and the anchor sleeve **870A** on external conduit **20A** are a first shoulder **882** and a second shoulder **884** which extend perpendicularly from the external conduit **20A** and are of a larger diameter. Between the connection sleeve **500A** and anchor sleeve **870A** (or if present the first and second shoulder **882**, **884**) are a first and second bearing rings **871A** and **872A**. External conduit **20A**, anchor sleeve **870A**, and connection sleeve may be prepared from the same or different biocompatible materials of suitable strength and flexibility for use in this type of tubing in a centrifuge (one such preferred material is HYTREL®). The connection sleeve **500A** and the anchor sleeve **870A** may be attached through any suitable means such as adhesives, welding etc., however, for ease of manufacture it is preferred that the connection sleeve **500A** and the anchor sleeve **870A** be overmolded to the external conduit **20A**.

[0099] Referring to FIGS. 45, 48 and 49 anchor sleeve **870A** comprises a body **877B** having a first anchor end **873A** and second anchor end **874A**. Anchor sleeve **870A** is attached to second conduit end **862A** of external conduit **20A** (preferably by overmolding) and increases in diameter from first collar **873A** to the collar **874A**. Spaced distally from second end **874A** is a collar **886A**, which extends perpendicularly from body **877B** and of a larger diameter than the body **877B** of the anchor sleeve **870A**. A plurality of ribs **877A** having a first rib end **877B** between the collar **886A** and second anchor end **873A** and a second rib end **877C** extending beyond the first anchor end **873A** are attached to the body **877B**. The second rib ends **877C** are joined together by a ring **880A**, which is also attached to external conduit **20A**. The ribs **877A** run parallel to the external conduit **20A** and are preferably placed over the region where conduit channels **760A**, **770A**, and **780A**, are closest to the surface of the external conduit **20A** (FIG. 50). The regions where the conduit channels **760A**, **770A** and **780A** are closest to the outside diameter of external conduit **20A** unless reinforced tend to fail during high speed rotation. Having ribs parallel with the conduit channels beyond the anchor sleeve end **873A** provides reinforcement to this region and prevents conduit failure at high speed rotation. In one aspect, the ribs prevent the buckling of the external conduit **20A** in this region and act as structural elements to transfer the torsional stress to the anchor sleeve **870A**.

[00100] Connection sleeve **500A** comprises body **830A** having an upper sleeve end **831A** and lower sleeve end **832A** (FIGS. 46 and 47). Lower sleeve end **832A** has sleeve flange **790A** and a plurality of protrusions **843A**, which are sized to engage indentations **484A** on the wall surface **482A** of lumen connector **481A**. When the bowl **10A** is assembled, a fluid tight seal may be provided by placing o-ring **791A** around body **830A** and compressing the o-ring **791A** between flange **790A** and housing **100A**. Upper sleeve end **831A** is adapted to be secured to external conduit **20A**. Referring to FIG. 46, 39A and 39B, connection sleeve **500A** is secured to bowl **10A** by means of sleeve flange **790A** and is adapted to fluidly connect conduit channels **780A**, **760A**, **770A** of external conduit **20A** to bowl channels **420A** and **410A**, and chamber **740A** of bowl **10A**. When assembled, connection sleeve **500A** is mounted to lumen connector **481A** (FIGS. 39A and 39B).

[00101] Connection sleeve **500A** preferably increases in diameter from upper sleeve end **831A** to lower sleeve end **832A** and is overmolded to first conduit end **861A** of external conduit **20A**. Connection sleeve **500A** connects bowl **10A** to external conduit **20A** without use of a rotatable seal, which would otherwise normally be located between bowl **10A** and connection sleeve **500A**. The seal-less connection between bowl **10A** and connection sleeve

**500A** may occur as explained above or alternatively through use of, for example, an O-ring, a groove, or lip, grommet-type connection, welding, or a tight fit with or without adhesive in either bowl **10A** or connection sleeve **500A**.

[00102] As illustrated in Figure 46 and 39B, sleeve flange **790A** has a bottom surface **847A** that contacts with top surface **482A** of lumen connector **481A** forming a tight seal. However, lumen connector **481A** has a plurality of indentation **483A** that provides for fluid communication between separation chamber **220A** and bowl chamber **740A**, which, in turn has fluid communication with conduit channel **770A**. Bowl chamber **740A** is defined by lumen mounting recess **851A** and top surface **482A** of lumen connector **481A**, excluding the space occupied by hollow cylinders **321A** and **322A**. A plurality of protrusions **843A** on the bottom surface **847A** of sleeve flange **790A** engages and slides into indentations **484A** on the wall surface **482B** of lumen connector **481A**, thus providing a tight fit.

[00103] Connection sleeve **500A** helps to secure external conduit **20A** to bowl **10A**, thus fluidly connecting external conduit **20A** to bowl **10A**. This fluid connection enables fluid **800** to be supplied through external conduit **20A** to bowl **10A**. Similarly, this fluid connection also enables separated fluid components **820** to be removed from bowl **10A** through external conduit **20A**.

[00104] External conduit **20A** has an approximately constant diameter which helps to reduce the rigidity. An excessively rigid external conduit **20A** will heat up and fail more quickly. Additionally, a constant diameter conduit is cheap/easy to manufacture, allows easy experimentation with connection sleeve **500A** and anchor sleeve **870A** sizes, and allows bearing rings **871A**, **872A** to be easily slid thereon. Preferably the movement of bearings **871A** and **872A** will be constrained by first and second shoulders **882A** and **884A**. External conduit **20A** may be made of any type of flexible tubing (such as medical tubing) or other such device providing a sealed passageway for the flow of fluids, which may be pressurized, into or out of a reservoir of any sort, and which preferably can be disposable and sterilizable.

## II. Permanent Tower System

[00105] FIG. 17 illustrates tower system **2000**. Tower system **2000** is the permanent (i.e., non-disposable) piece of hardware that receives the various devices of photopheresis kit **1000**, such as, cassette **1100**, irradiation chamber **700**, and centrifuge bowl **10** (FIG. 1). Tower system **2000** performs the valving, pumping, and overall control and drive of fluid flow through disposable photopheresis kit **1000**. Tower system **2000** performs all of the

necessary control function automatically through the use of a properly programmed controller, for example a processor or IC circuit, coupled to all of the necessary components. While a new disposable kit must be discarded after each photopheresis therapy session, tower system **2000** is used over and over again. Tower system **2000** can be modified to perform a number of extracorporeal blood circuit treatments, for example apheresis, by properly programming the controller or by changing some of its components.

[00106] Tower system **2000** has a housing having an upper portion **2100** and a base portion **2200**. Base portion **2200** has a top **2201** and a bottom **2202**. Wheels **2203** are provided at or near the bottom **2202** of base portion **2200** so that tower system **2000** is mobile and can easily be moved from room to room in a hospital setting. Preferably, the front wheels **2203** are pivotable about a vertical axis to allow ease in steering and maneuvering tower system **2000**. Top **2201** of base portion **2200** has a top surface **2204** having control deck **1200**, best illustrated in FIG. 22, built therein (see FIG.22). In FIG. 17, cassette **1100** is loaded onto control deck **1200**. Base portion **2200** also has hooks (not illustrated), or other connectors, to hang plasma collection bag **51** and treatment bag **50** therefrom. Such hooks can be located anywhere on tower system **2000** so long as their positioning does not interfere with the functioning of the system during therapy. Base portion **2200** has photoactivation chamber **750** (FIG. 18) located behind door **751**. Additional hooks (not illustrated) are provided on tower system **2000** for hanging saline and anticoagulant bags. Preferably, these hooks are located on upper portion **2100**.

[00107] Photoactivation chamber **750** (FIG. 18) is provided in base portion **2200** of tower system **2000** between top **2201** and bottom **2202** behind door **751**. Door **751** is hingedly connected to base portion **2200** and is provided for access to photoactivation chamber **750** and to allow the operator to close photoactivation chamber **750** so that UV light does not escape into the surrounding during treatment. Recess **752** is provided to allow tubes **1112**, **1117** (FIG. 1) to pass into photoactivation chamber **750** when irradiation chamber **700** is loaded and when door **751** is closed. The photoactivation chamber is discussed in detail below with respect to FIGS. 16 and 18.

[00108] Upper portion **2100** is located atop base portion **2200**. Centrifuge chamber **2101** (FIG. 19) is located in upper portion **2100** behind centrifuge chamber door **2102**. Centrifuge chamber door **2102** has a window **2103** so an operator can see in centrifuge chamber **2101** and monitor for any problems. Window **2103** is constructed with glass thick enough to withstand any forces that may be exerted on it from an accident during

centrifugation which can rotate the centrifuge bowl at speeds greater than 4800 RPMs. Preferably, window **2103** is constructed of shatter-proof glass. Door **2102** is hingedly connected to upper portion **2100** and has an automatic locking mechanism that is activated by the system controller during system operation. Centrifuge chamber **2101** is discussed below in more detail with respect to FIG. 19.

**[00109]** Preferably, deck **1200** is located on top surface **2204** of base portion **2200** at or near the front of system tower **2000** while upper portion **2100** is extending upward from base portion **2200** near the rear of tower system **2000**. This allows the operator easy access to control deck **1200** while simultaneously affording the operator access to centrifuge chamber **2101**. By designing tower system **2000** to have the centrifuge chamber **2101** in the upper portion **2100** and having the photoactivation chamber **750** and deck **1200** in base portion **2200**, an upright configuration is achieved. As such, system tower **2000** has a reduced footprint size and takes up a reduced amount of valuable hospital floor space. The height of system tower **2000** remains below sixty inches so that one view is not obstructed when transporting the machine around the hospital from the rear. Additionally, having deck **1200** in a fairly horizontal position will provide the operator with a place to set devices of photopheresis kit **1000** during the loading of other devices, facilitating easy loading. Tower system **2000** is robust enough to withstand forces and vibrations brought on by the centrifugation process.

**[00110]** A monitor **2104** is provided on centrifuge chamber door **2102** above window **2103**. Monitor **2104** has a display area **2105** for visually displaying data to an operator, such as, for example, user interfaces for data entry, loading instructions, graphics, warnings, alerts, therapy data, or therapy progress. Monitor **2104** is coupled to and controlled by the system controller. A data card receiving port **2001** is provided on a side of monitor **2104**. Data card receiving port **2001** is provided to slidably receive data card **1195** which is supplied with each disposable photopheresis kit **1000** (FIG. 1). As mentioned above, data card **1195** can be pre-programmed to store serve a variety of data to supply to the system controller of tower system **2000**. For example, data card **1195** can be programmed to relay information so that the system controller can ensure: (1) that the disposable photopheresis kit is compatible with the blood drive equipment into which it is being loaded; (2) that the photopheresis kit is capable of running the desired treatment process; (3) that the disposable photopheresis kit is of a certain brand name or make. Data card receiving port **2001** has the necessary hardware and circuitry to both read data from, and write data to, data card **1195**. Preferably, data card

receiving port **2201** will record treatment therapy data to data card **1195**. Such information can include for example, collection times, collection volumes, treatment times, volumetric flow rates, any alarms, malfunctions, disturbances in the process, or any other desired data. While data card receiving port **2001** is provided on monitor **2104**, it can be located anywhere on tower system **2000** so long as it is coupled to the system controller or other appropriate control means.

#### A. Photoactivation Chamber for Receiving Irradiation Chamber

**[00111]** Referring now to FIGS. 16 and 18, photoactivation chamber **750** is illustrated in cross section. Photoactivation chamber **750** is formed by housing **756**. Housing **756** fits within base portion **2200** of tower system **2000** behind door **751** (FIG. 17). Photoactivation chamber **750** has a plurality of electrical connection ports **753** provided on back wall **754**. Electrical connection ports **753** are electrically coupled to a source of electrical energy. Photoactivation chamber **750** is designed to receive UVA light assembly **759** (FIG. 16). When fully loaded into photoactivation chamber **750**, electrical contacts (not illustrated) located on contact wall **755** of UVA light assembly **759** form an electrical connection with electrical connection ports **753**. This electrical connection allows electrical energy to be supplied to UVA lamps **758** so that they can be activated. Preferably, three electrical connection ports are provided for each set of UVA lamps **758**. More preferably, UVA light assembly **759** has two sets of UVA lamps **758** forming a space which irradiation chamber **700** can be inserted. The supply of electrical energy to UVA lamps **758** is controlled by the properly programmed system controller using a switch. UVA lamps **758** are activated and deactivated as necessary by the controller during the photopheresis therapy session.

**[00112]** Vent hole **757** is provided in the top of housing **756** near back wall **754** of photoactivation chamber **750**. Vent hole **757** connects to vent duct **760** which leads out of the back of tower system **2000**. When heat generated by UVA lamps **758** builds up in photoactivation chamber **750** during a treatment therapy, this heat escapes photoactivation chamber **750** via vent hole **757** and vent duct **760**. The heat exits tower system **2000** through tower housing hole **761** located in the rear of tower system **2000**, away from the patient and the operator.

**[00113]** Photoactivation chamber **750** further comprises tract **762** for receiving irradiation chamber **700** and holding irradiation in an upright position between UVA lamps **758**. Tract **762** is at or near the bottom of photoactivation chamber **750**. Preferably, a leak

detector circuit **763** is provided below tract **762** to detect any fluid leaks irradiation chamber **700** during, before, or after operation. Leak detector circuit **762** has two electrodes patterned in a U shape located on an adhesive backed flex circuit. The electrodes are designed to allow for application of a short circuit to test for discontinuities. One end of each electrode goes to an integrated circuit while the other end of each electrode is tied to a solid-state switch. The solid-state switch can be used to check for continuity of the electrodes. By closing the switch the electrodes are shorted to one another. The integrated circuit then detects the short. Closing the switch causes a situation equivalent to the electrodes getting wet (i.e., a leak). If the electrodes are damaged in any way, the continuity check will fail. This is a positive indication that the electrodes are not damaged. This test can be performed each time at system start-up or periodically during normal operation to ensure that leak detection circuit **762** is working properly. Leak detection circuit **762** helps ensure that leaks do not go unnoticed during an entire therapy session because the leak detection circuit is damaged. An electrical schematic of leak detector circuit **762** is provided in FIG. 20.

#### B. Centrifuge Chamber

[00114] FIG. 19 illustrates centrifuge chamber **2101** in cross section with the housing of tower system **2000** removed. Rotational device **900** (also in cross-section) capable of utilizing 1-omega 2-omega spin technology is positioned within centrifuge chamber **2101**. Rotational device **900** includes a rotating bracket **910** and a bowl holding plate **919** for rotatably securing centrifuge bowl **10** (FIG. 1). Housing **2107** of centrifuge chamber **2101** is preferably made of aluminum or some other lightweight, sturdy metal. Alternatively, other rotational systems may be used within tower system **2000** such as that described in U.S. Patent No. 3,986,442, which is expressly incorporated herein by reference in its entirety.

[00115] Leak detection circuit **2106** is provided on back wall **2108** of housing **2107**. Leak detection circuit **2106** is provided to detect any leaks within centrifuge bowl **10** or the connecting tubes during processing. Leak detection circuit **2106** is identical to leak detector circuit **762** described above. An electrical schematic of leak detection circuit **2106** is provided in FIG. 21.

#### C. Fluid Flow Control Deck

[00116] FIG. 22 illustrates control deck **1200** of tower system **2000** (FIG. 17) without a cassette **1100** loaded thereon. Control deck **1200** performs the valving and pumping so as



to drive and control fluid flow throughout photopheresis kit **1000**. Preferably, deck **1200** is a separate plate **1202** that is secured to base portion **2200** of tower system **2000** via screws or other securing means, such as, for example, bolts, nuts, or clamps. Plate **1202** can be made of steel, aluminum, or other durable metal or material.

**[00117]** Deck **1200** has five peristaltic pumps, whole blood pump **1301**, return pump **1302**, recirculation pump **1303**, anticoagulant pump **1304**, and red blood cell pump **1305** extending through plate **1202**. Pumps **1301-1305** are arranged on plate **1202** so that when cassette **1100** is loaded onto deck **1200** for operation, pump loop tubes **1120-1124** extend over and around pumps **1301-1305** (FIG. 25).

**[00118]** Air bubble sensor assembly **1204** and HCT sensor assembly **1205** are provided on plate **1202**. Air bubble sensor assembly **1204** has three trenches **1206** for receiving tubes **1114**, **1106**, and **1119** (FIG. 25). Air bubble sensor assembly **1204** uses ultrasonic energy to monitor tubes **1114**, **1106**, and **1119** for differences in density that would indicate the presence of air in the liquid fluids normally passing therethrough. Tubes **1114**, **1106**, and **1119** are monitored because these lines go to the patient. Air bubble sensor assembly **1204** is operably coupled and transmits data to the system controller for analysis. If an air bubble is detected, the system controller will shut down operation and prohibit fluid flow into the patient by occluding tubes **1114**, **1106**, and **1109** by moving compression actuators **1240-1242** to a raised position, thereby compressing tubes **1114**, **1106**, and **1119** against cassette **1100** as discussed above and/or shutting down the appropriate pump. HCT sensor assembly **1205** has trench **1207** for receiving HCT component **1125** of tube **1116**. HCT sensor assembly **1205** monitors tube **1116** for the presence of red blood cells by using a photoelectric sensor. HCT sensor assembly **1205** is also operably coupled to and transmits data to the system controller. Upon HCT sensor assembly **1205** detecting the presence of red blood cells in tube **1116**, the system controller will take the appropriate action, such as stopping the appropriate pump or activating one of compression actuators **1243-1247**, to stop fluid flow through tube **1116**.

**[00119]** Deck **1200** also has five compression actuators **1243-1247** and three compression actuators **1240-1242** strategically positioned on plate **1202** so that when cassette **1100** is loaded onto deck **1200** for operation, each of compression actuators **1240-1247** are aligned with corresponding apertures **1137** and **1157**. Compression actuators **1240-1247** can be moved between a lowered position and a raised position. As illustrated in FIG. 22, compression actuators **1243-1247** are in the lowered position and compression actuators

**1240-1242** are in the raised position. When in a raised position, and when cassette **1100** is loaded onto deck **1200** as illustrated in FIG 25, compression actuators **1240-1247** will extend through the corresponding apertures **1137** or **1157** and compress the portion of flexible tubing that is aligned with that aperture, thereby pinching the flexible tube shut so that fluid can not pass. When in the lowered position, compression actuators **1240-1247** do not extend through apertures **1137** and **1157** and thus do not compress the flexible tubing.

[00120] Compression actuators **1243-1247** are spring retracted so that their default position is to move to the lowered position unless activated. Compression actuators **1243-1247** are independently controlled and can be raised or lowered independent of one another. Compression actuators **1240-1242** on the other hand are coupled together. As such, when one compression actuator **1240-1242** is lowered or raised, the other two compression actuators **1240-1242** are also lowered or raised accordingly. Additionally, compression actuators **1240-1242** are spring loaded so that their default position is to move to the raised position. Thus, if the system loses power during a therapy session, compression actuators **1240-1242** will automatically move to the raised position, occluding tubes **1114**, **1106**, and **1119** and preventing fluids from entering or leaving the patient.

[00121] Referring now to FIGS. 23 and 24, deck **1200** further includes system controller **1210**, cylinder assembly **1211**, manifold assemblies **1213**, pump cable **1215**, pump motor cable **1216**, and timing belt assembly **1217**. System controller **1210** is a properly programmed integrated circuit that is operably coupled to the necessary components of the system to perform all of the functions, interactions, decisions, and reaction discussed above and necessary to perform a photopheresis therapy according to the present invention. Cylinder assembly **1211** couples each of compression actuators **1240-1247** to a pneumatic cylinder. Air ports **1212** are provided on the various elements of deck **1200** as necessary to connect air lines to the devices and the appropriate one of manifolds **1213**. As such, air can be provided to the devices as necessary to actuate the necessary component, such as compression valves **1240-1247**. All of these functions and timing are controlled by system controller **1210**. Timing belt assembly **1217** is used to coordinate the rotation of rotating clamps **1203**. Finally, plate **1202** includes a plurality of holes **1215**, **1219**, **1220**, **1221**, and **1218** so that the various components of deck **1200** can be properly loaded into and so that deck **1200** can be secured to tower system **2000**. Specifically, pumps **1301-1305** fit into holes **1314**, HCT sensor assembly **1205** fits into hole **1220**, air bubble detector assembly

**1204** fits into hole **1219**, compression actuators **1240-1247** extend through holes **1218**, and bolts extend through holes **1221** to secure deck **1200** to tower assembly **2000**.

### 1. Cassette Clamping Mechanism

**[00122]** Referring now to FIGS. 22 and 25, the method by which cassette **1100** is loaded and secured to deck **1200** will now be discussed. In order for system **2000** to perform a photopheresis therapy, cassette **1100** must be properly loaded onto deck **1200**. Because of the compression actuator valving system incorporated in the present invention, it is imperative that cassette **1100** be properly secured to deck **1200** and not shift or become dislodged when compression actuators **1240-1247** occlude portions of the flexible tubing by compressing the flexible tubing against cover **1130** of cassette **1100** (FIG. 3). However, this requirement competes with the desired goals of ease in loading cassette **1100** onto deck **1200** and reducing operator errors. All of these goals are achieved by the below described cassette clamping mechanism.

**[00123]** In order to facilitate clamping of cassette **1100** to deck **1200**, deck **1200** is provided with two catches **1208** and two rotating clamps **1203** and **1223**. Catches **1208** have a slot **1228** near the middle of the top plate. Catches **1208** are secured to plate **1202** at predetermined positions so that the spacing between them is substantially the same as the spacing between tabs **1102** and **1103** on cassette **1100** (FIG. 2). Rotating clamps **1203** and **1223** are illustrated in a closed position. However, rotating clamps **1203** and **1223** can be rotated to an open position (not illustrated) manually or through the automatic actuation of a pneumatic cylinder. Rotating clamps **1203** and **1223** are spring loaded by torque springs so as to automatically return to the closed position when additional torque is not being applied. Rotating clamps **1203** and **1223** are linked together by timing belt assembly **1217** (FIG. 24).

**[00124]** Referring now to FIG. 23, timing belt assembly **1217** comprises timing belt **1226**, torque spring housings **1224**, and tension assembly **1225**. Timing belt assembly **1217** coordinates the rotation of rotational clamps **1203** and **1223** so that if one is rotated, the other also rotates in the same direction and the same amount. In other words, rotational clamps **1203** and **1223** are coupled. Tension assembly **1217** ensures that timing belt **1226** is under sufficient tension to engage and rotate the rotational clamp **1203** or **1223** that is being coordinated. Torque spring housings **1224** provide casings for the torque springs that torque rotational clamps **1203** and **1223** to the closed position.

[00125] Referring back to FIGS. 22 and 25, when loading cassette **1100** onto deck **1200**, cassette **1100** is placed at an angle to deck **1200** and tabs **1102** and **1103** (FIG. 2) are aligned with catches **1208**. Cassette **1100** is moved so that tabs **1102** and **1103** slidably insert into catches **1208**. Rotational clamps **1203** and **1223** are in the closed position at this time. The rear of the cassette **1100** (i.e. the side opposite the tabs **1102** and **1103**) contacts rotational clamps **1203** and **1223** as tabs **1102** and **1103** are being inserted in catches **1108**. As force is applied downward on cassette **1100**, rotational clamps **1103** and **1123** will be rotated to the open position, allowing the rear of cassette **1100** to move downward to a position below ledges **1231** of rotational clamps **1203** and **1223**. Once cassette **1100** is in this position, the rotational clamps **1203** and **1223** spring back from the force applied by the torque springs and rotate back to the closed position, locking cassette **1100** in place. When in the locked position, cassette **1100** can resist upward and lateral forces.

[00126] To remove cassette **1110** after the therapy session is complete, rotational clamps **1203** and **1223** are rotated to the open position either manually or automatically. Automatic rotation is facilitated by an air cylinder that is coupled to an air line and system controller **1210**. Once rotational clamps **1203** and **1223** are in the open position, cassette **1100** is removed by simple lifting and sliding tabs **1102** and **1103** out of catches **1208**.

## 2. Self-Loading Peristaltic Pumps

[00127] Referring to FIG. 24, peristaltic pumps **1301-1305** are provided on deck **1200** and are used to drive fluids through photopheresis kit **1000** (FIG. 1) along desired pathways. The activation, deactivation, timing, speed, coordination, and all other functions of peristaltic pumps **1301-1305** are controlled by system controller **1210**. Peristaltic pumps **1301-1305** are identical in structure. However, the placement of each peristaltic pump **1301-1305** on deck **1200** dictates the function of each peristaltic pump **1301-1305** with respect to which fluid is being driven and along which pathway. This is because the placement of peristaltic pumps **1301-1305** dictates which pump loop **1220-1224** will be loaded therein.

[00128] Referring now to FIGS. 28 and 29, whole blood pump **1301** is illustrated in detail. The structure and functioning of whole blood pump will be described with the understanding that peristaltic pumps **1302-1305** are identical. Whole blood pump **1301** has motor **1310**, position sensor **1311**, pneumatic cylinder **1312**, pneumatic actuator **1313**, rotor **1314** (best illustrated in FIG. 30), and housing **1315**.

**[00129]** Rotor **1314** is rotatably mounted within housing **1315** and is in operable connection with drive shaft **1316** of motor **1310**. Specifically, rotor **1314** is mounted within curved wall **1317** of housing **1315** so as to be rotatable by motor **1310** about axis **A-A**. When rotor **1314** is mounted in housing **1315**, a space **1318** exists between rotor **1314** and curved wall **1317**. This space **1318** is the tube pumping region of whole blood pump **1301** into which pump loop tube **1121** (FIG. 33) fits when loaded for pumping. Position sensor **1316** is coupled to drive shaft **1316** of motor **1310** so that the rotational position of rotor **1314** can be monitored by monitoring drive shaft **1316**. Position sensor **1311** is operably connected and transmits data to system controller **1210** (FIG. 24). By analyzing this data, system controller **1210**, which is also coupled to motor **1310**, can activate motor **1310** to place rotor **1314** in any desired rotational position.

**[00130]** Housing **1315** also includes a housing flange **1319**. Housing flange **1319** is used to secure whole blood pump **1310** to plate **1202** of deck **1200** (FIG. 22). More specifically, a bolt is extended through bolt holes **1320** of housing flange **1319** to threadily engage holes within plate **1202**. Housing flange **1319** also includes a hole (not shown) to allow pneumatic actuator **1313** to extend therethrough. This hole is sized so that pneumatic actuator **1313** can move between a raised and lowered position without considerable resistance. Pneumatic actuator **1313** is activated and deactivated by pneumatic cylinder **1312** in a piston-like manner through the use of air. Pneumatic cylinder **1312** comprises air inlet hole **1321** for connecting an air supply line. When air is supplied to pneumatic cylinder **1312**, pneumatic actuator extends upward through housing flange **1319** to a raised position. When air ceases to be supplied to pneumatic cylinder **1312**, pneumatic actuator retracts back into pneumatic cylinder **1312**, returning to the lowered position. System controller **1210** (FIG. 22) controls the supply of air to air inlet hole **1321**.

**[00131]** Curved wall **1317** of housing **1315** contains two slots **1322** (only one visible). Slots **1322** are located on substantially opposing sides of curved wall **1317**. Slots **1322** are provided for allowing pump loop tube **1121** (FIG. 33) to pass into tube pumping region **1318**. More specifically, pump inlet portion **1150** and outlet portions **1151** (FIG. 33) of pump loop tube **1121** pass through slots **1322**.

**[00132]** Turning now to FIGS. 30 and 31, rotor **1314** is illustrated as removed from housing **1315** so that its components are more clearly visible. Rotor **1314** has a top surface **1323**, angled guide **1324**, rotor flange **1325**, two guide rollers **1326**, two drive rollers **1327**, and rotor floor **1328**. Guide rollers **1326** and drive rollers **1327** are rotatably secured about

cores 1330 between rotor floor 1328 and a bottom surface 1329 of rotor flange 1325. As is best illustrated in FIG. 29, cores 1330 fit into holes 1331 of rotor floor 1328 and recesses 1332 in bottom surface 1329. Guide rollers 1326 and drive rollers 1327 fit around cores 1330 and can rotate thereabout. Preferably, two guide rollers 1326 and two drive rollers 1327 are provided. More preferably, guide rollers 1326 and drive rollers 1327 are provided on rotor 1314 so as to be in an alternating pattern.

[00133] Referring to FIGS. 29 and 31, drive rollers 1327 are provided to compress the portion of pump loop tube 1121 that is loaded into tube pumping region 1318 against the inside of curved wall 1317 as rotor 1314 rotates about axis A-A, thereby deforming the tube and forcing fluids to flow through the tube. Changing the rotational speed of rotor 1314 will correspondingly change the rate of fluid flow through the tube. Guide rollers 1326 are provided to keep the portion of pump loop tube 1121 that is loaded into tube pumping region 1318 properly aligned during pumping. Additionally, guide rollers 1326 help to properly load pump tube loop 1121 into tube pumping region 1318. While guide rollers 1326 are illustrated as having a uniform cross-section, it is preferred that the top plate of the guide rollers be tapered so as to come to a sharper edge near its outer diameter. Tapering the top plate results in a guide roller with a non-symmetric cross-sectional profile. The tapered embodiment helps ensure proper loading of the tubing into the tube pumping region.

[00134] Rotor 1314 further includes cavity 1328 extending through its center. Cavity 1328 is designed to connect rotor 1314 to drive shaft 1316 of motor 1310.

[00135] Referring now to FIGS. 30 and 32, rotor flange has opening 1333. Opening 1333 is defined by a leading edge 1334 and a trailing edge 1335. The terms leading and trailing are used assuming that rotating rotor 1314 in the clockwise direction is the forward direction while rotating rotor 1314 in a counterclockwise direction is the rearward direction. However, the invention is not so limited and can be modified for counterclockwise pumps. Leading edge 1334 is beveled downward into opening 1333. Trailing edge 1335 extends upward from the top surface of rotor flange 1325 higher than the leading edge 1334. Leading edge is provide for trailing edge for capturing and feeding pump loop tube 1121 into tube pumping region 1318 upon rotor 1314 being rotated in the forward direction.

[00136] Rotor 1314 also has angled guide 1324 extending upward, at an inverted angle, from rotor flange 1325. Angled guide 1324 is provided for displacing pump loop tube 1121 toward rotor flange 1325 upon rotor 1314 being rotated in the forward direction. Preferably, angled guide 1324 has elevated ridge 1336 running along top surface 1323 for

manual engagement by an operator if necessary. More preferably, angled guide **1314** is located forward of leading edge **1334**.

**[00137]** Referring now to FIGS. 28 and 33, whole blood pump **1301** can automatically load and unload pump loop tube **1121** into and out of tube pumping region **1318**. Using position sensor **1311**, rotor **1314** is rotated to a loading position where angled guide **1324** will face cassette **1100** when cassette **1100** is loaded onto deck **1200** (FIG. 25). More specifically, rotor **1314** is preset in a position so that angled guide **1324** is located between inlet portion **1150** and outlet portion **1151** of pump loop **1121** when cassette **1100** is secured to the deck, as is illustrated in FIG. 13. When cassette **1100** is secured to deck **1200**, pump loop tube **1121** extends over and around rotor **1314**. Pneumatic actuator **1313** is in the lowered position at this time.

**[00138]** Once cassette **1100** is properly secured and the system is ready, rotor **1314** is rotated in the clockwise direction (i.e., the forward direction). As rotor **1314** rotates, pump tube loop **1121** is contacted by angled guide **1324** and displaces against the top surface of rotor flange **1325**. The portions of pump loop tube **1121** that are displaced against rotor flange **1325** are then contacted by trailing edge **1325** and fed downward into tube pumping region **1318** through opening **1333**. A guide roller **1326** is provided directly after opening **1333** to further properly position the tubing within tube pumping chamber for pumping by drive rollers **1327**. When loaded, inlet portion **1150** and outlet portion **1151** of pump loop tube **1121** pass through slots **1322** of curved wall **1317**. One and a half revolutions are needed to fully load the tubing.

**[00139]** To automatically unload pump tube loop **1121** from whole blood pump **1301** after the therapy is complete, rotor **1314** is rotated to a position where opening **1333** is aligned with the slot **1322** through which outlet portion **1151** passes. Once aligned, pneumatic actuator **1313** is activated and extended to the raised position, contacting and lifting outlet portion **1151** to a height above trailing edge **1335**. Rotor **1314** is then rotated in the counterclockwise direction, causing trailing edge to **1335** to contact and remove pump loop tube **1121** from tube pumping region **1318** via opening **1333**.

#### D. Infra-Red Communication

**[00140]** Referring to FIG. 34, tower system **2000** (FIG. 17) preferably further includes a wireless infrared (“IR”) communication interface (not shown). The wireless IR interface consists of three primary elements, system controller **1210**, IRDA protocol integrated circuit,

**1381**, and IRDA transceiver port **1382**. The IR communication interface is capable of both transmitting and receiving data via IR signals from a remote computer or other device having IR capabilities. In sending data, system controller **1210** sends serial communication data to the IRDA protocol chip **1381** to buff the data. IRDA protocol chip **1381** adds additional data and other communication information to the transmit string and then sends it to IRDA transceiver **1382**. Transceiver **1382** converts the electrical transmit data into encoded light pulses and transmits them to a remote device via a photo transmitter.

**[00141]** In receiving data, IR data pulses are received by a photo detector located on the transceiver chip **1382**. The transceiver chip **1382** converts the optical light pulses to electrical data and sends the data stream to IRDA protocol chip **1381** where the electrical signal is stripped of control and additional IRDA protocol content. The remaining data is then sent to the system controller **1210** where the data stream is parsed per the communication protocol.

**[00142]** By incorporating an IR communication interface on tower system **2000** real time data relating to a therapy session can be transmitted to a remote device for recording, analysis, or further transmission. Data can be sent via IR signals to tower system **2000** to control the therapy or allow protocols to be changed in a blinded state. Additionally, IR signals do not interfere with other hospital equipment, like other wireless transmission methods, such as radio frequency.

### III. Photopheresis Treatment Process

**[00143]** Referring together to Fig. 26, a flow chart illustrating an embodiment of the invention which includes photactivation of buffy coat, and Fig. 27, a schematic representation of apparatus which can be employed in such an embodiment, the process starts **1400** with a patient **600** connected by means of a needle adapter **1193** carrying a needle, for drawing blood, and needle adapter **1194** carrying another needle, for returning treated blood and other fragments. Saline bag **55** is connected by connector **1190** and anticoagulant bag **54** is connected by connector **1191**. Actuators **1240**, **1241**, and **1242** are opened, anticoagulant pump **1304** is turned on, and saline actuator **1246** is opened so that the entire disposable tubing set is primed **1401** with saline **55** and anticoagulant **54**. The centrifuge **10** is turned on **1402**, and blood-anticoagulant mixture is pumped **1403** to the centrifuge bowl **10**, with the A/C pump **1304** and WB pump **1301** controlled at a 1:10 speed ratio.



**[00144]** When the collected volume reaches 150 ml **1404**, the return pump **1302** is set **1405** at the collection pump **1301** speed until red cells are detected **1406** at an HCT sensor (not shown) in the centrifuge chamber **1201** (Fig. 19). Packed red cells and buffy coat have at this point accumulated in the spinning centrifuge bowl and are pumped out slowly at a rate, controlled by the processor, which maintains the red cell line at the sensor interface level.

**[00145]** The red cell pump **1305** is then set **1407** at 35% of the inlet pump speed while controlling **1408** the rate to maintain the cell line at the interface level until the collection cycle volume is reached **1409**, at which point the red cell pump **1305** is turned off **1410** and the fluid path to the treatment bag **50** via the HCT sensor **1125** is opened by lowering actuator **1244**, and stops when the HCT sensor **1125** detects **1411** red cells. "Collection cycle volume" is defined as the whole blood processed target divided by the number of collection cycles, for example a white blood process target of 1500 ml may require 6 cycles, and so  $1500/6$  is a volume of 250 ml. With whole blood continuing at **1410** to be delivered from the patient to the bowl and the red cell pump off, red cells will accumulate and will push out the buffy coat from inside the bowl **10**. The red cells are used to push out the buffy coat and will be detected by the effluent hematocrit (HCT) sensor, indicating that the buffy coat has been collected.

**[00146]** If another cycle is needed **1412**, the centrifuge **10** effluent path is returned **1413** to the plasma bag **51** and the red cell pump **1305** rate is increased **1413** to the inlet pump **1301** pump rate until red cells are detected **1414**, which is the beginning of the second cycle. If another cycle **1412** is not needed, the centrifuge **10** is turned off **1415** and inlet pump **1301** and anticoagulant pump **1304** are set at KVO rate, 10 ml/hr in this embodiment. The effluent path is directed **1416** to the plasma bag **51**, the red cell pump **1305** rate is set **1417** at 75 ml/min, the recirculation pump **1303** and photoactivation lamps are turned on **1418** for sufficient period to treat the buffy coat, calculated by the controller depending on the volume and type of disease being treated.

**[00147]** When the bowl **10** is empty **1419**, the red cell pump **1305** is turned off **1420** and the plasma bag **51** is emptied **1421** by opening actuator **1247** and continuing return pump **1302**. The return pump **1302** is turned off **1422** when the plasma bag **51** is empty and when photoactivation is complete **1423**, the treated cells are returned **1424** to the patient from the plate **700** by means of the return pump **1302**. Saline is used to rinse the system and the rinse is returned to the patient, completing the process **1425**.

**[00148]** The anticoagulant, blood from patient, and fluid back to patient are all monitored by air detectors 1204 and 1202, and the fluid back to the patient goes through drip chamber and filter 1500. The pumps, 1304, 1301, 1302, 1303, and 1305, the actuators 1240, 1241, 1242, 1243, 1244, 1245, 1246, and 1247, and the spinning of the bowl 10 are all controlled by the programmed processor in the tower.

**[00149]** The process and related apparatus have significant advantages over prior processes and apparatus in that the invention allow buffy coat to be in the bowl longer since red cells are being drawn off while collecting buffy coat in the bowl while centrifuging, keeping more buffy coat in the bowl until the desired amount of buffy coat cells are collected prior to withdrawing the collected buffy cells. Platelets, leukocytes, and other buffy coat fractions can also be separated, or red cells can be collected rather than returning them with plasma to the patient as the illustrated process does.

**[00150]** It has been found that increasing the time that buffy coat **810** is subjected to rotational motion in centrifuge bowl **10** yields a “cleaner cut” of buffy coat **820**. A “cleaner cut” means that the hematocrit count (HCT%) is decreased. HCT% is the amount of red blood cells present per volume of buffy coat. The amount of time that buffy coat **820** is subjected to rotational motion in centrifuge bowl **10** can be maximized in the following manner. First, whole blood **800** is fed into first bowl channel **420** as centrifuge bowl **10** is rotating. As discussed above, whole blood **800** is separated into buffy coat **820** and RBC's **810** as it moves outwardly atop lower plate **300**. Second bowl channel **410** and third bowl channel **740** are closed at this time. The inflow of whole blood **800** is continued until the separation volume **220** is filled with a combination of buffy coat **820** near the top and RBC's **810** near the bottom of centrifuge bowl **10**. By removing RBC's **810** from centrifuge bowl **10** via second bowl channel **410** only, additional volume is created for the inflow of whole blood **800** and the unremoved buffy coat **820** is subjected to rotational forces for an extended period of time. As centrifuge bowl **10** continues to rotate, some of the RBC's **810** that may be trapped in buffy coat **820** get pulled to the bottom of centrifuge bowl **10** and away from third bowl channel **740** and buffy coat **820**. Thus, when third bowl channel **740** is opened, the buffy coat **820** that is removed has a lower HCT%. By controlling the inflow rate of whole blood **800** and the outflow rates of buffy coat **820** and RBC's **810**, a steady state can be reached that yields a buffy coat **820** with an approximately constant HCT%.

**[00151]** The elimination of batch processing and the improved yields achieved by the current invention, have reduced the treatment time necessary to properly treat patients. For

an average sized adult, 90-100 milliliters of buffy coat/white blood cells must be captured in order to conduct a full photopheresis treatment. In order to collect this amount of buffy coat/white blood cells, the present invention needs to process around 1.5 liters of whole blood. The required amount of buffy coat/white blood cells can be removed from the 1.5 liters of whole blood in about 30-45 minutes using the present invention, collecting around 60% or more of the total amount of the buffy coat/white blood cells that are subjected to the separation process. The captured buffy coat/white blood cells have an HCT of 2% or less. In comparison, one existing apparatus, the UVAR XTS, takes around 90 minutes to process 1.5 liters of whole blood to obtain the sufficient amount of buffy coat/white blood cells. The UVAR XTS only collects around 50% of the total amount of the buffy coat/white blood cells that are subjected to the separation process. The HCT of the buffy coat/white blood cells collected by the UVAR XTS is around, but not substantially below, 2%. Another existing apparatus, the Cobe Spectra™ by Gambro, must process 10 liters of whole blood in order to collect the sufficient amount of buffy coat/white blood cells. This typically takes around 150 minutes, collecting only 10-15% of the total amount of the buffy coat/white blood cells that are subjected to the separation process, and having an HCT of about 2%. Thus, it has been discovered that while existing apparatus and systems require anywhere from 152 to 225 minutes to separate, process, treat, and reinfuse the requisite amount of white blood cells or buffy coat, the present invention can perform the same functions in less than 70 minutes. These times do not include the patient preparation or prime time. The times indicate only the total time that the patient is connected to the system.

## Claims

What is claimed is:

1. An apparatus for separating components of a fluid comprising:
  - an outer housing with an upper housing end and a lower housing end, wherein said outer housing increases in diameter from said upper housing end to said lower housing end, said lower housing end having a housing floor and said housing upper end having a housing outlet, said outer housing adapted for rotation about a center axis;
  - said outer housing containing a core in said interior volume; the core having an outer wall, an upper core end, and a lower core end; said core connected with said outer housing for rotation therewith; and providing a separation volume between said core and said outer housing; said core end having a lumen connector and a lumen connector top surface;
  - a first lumen for providing fluid communication from the housing outlet through the lumen connector and then radially outward through the core to the fluid separation volume ;
  - a second lumen providing fluid communications from the housing outlet extending axially along center axis to housing floor;
  - a connection sleeve which forms with the lumen connector a chamber and provide fluid communications between the housing outlet and the separation volume.
2. An apparatus of claim 1 wherein said first lumen extending radially out to outer housing about midway to said housing floor.
3. An apparatus of claim 1 wherein said lumen extending radially out to outer housing about midway to said housing floor through one to eight channels.

4. An apparatus of claim 1 wherein said outer wall of said top core increases in diameter from said upper end to said lower end.
5. An apparatus of claim 1 wherein connection sleeve is adapted to be secured to said apparatus near said housing outlet of said outer housing for rotation therewith, said connection sleeve adapted to fluidly connect a first bowl channel, second bowl channels, and a chamber.

6. An apparatus for separating components of a fluid comprising:

an outer housing with an upper housing end and a lower housing end, wherein said outer housing increases in diameter from said upper housing end to said lower housing end, said lower housing end having a housing floor and said housing upper end having a housing outlet, said outer housing having an interior volume and adapted for rotation about a center axis;

a top core having an outer wall, an upper top core end, and a lower top core end; said top core connected with said outer housing for rotation therewith; occupying a top coaxial volume of said interior volume of said outer housing; and providing a top separation volume between said top core and said outer housing;

said upper top core end having a lumen connector; said lumen connector having a first lumen wall extending downward from the a top surface of the lumen connector; said lumen connector further having an inner lumen wall within said first lumen wall and extending downward from the top surface; said inner lumen wall having a top wall end and a bottom wall end;

an upper plate having a top surface, a bottom surface, a second lumen wall extending above said top surface; said upper plate adapted to form a tight fit with the lower top core end for rotation therewith;

said second lumen wall (402A) adapted to overlap with said first lumen wall (401A) to form a lumen (400A) having an upper lumen end (480A) and a

lower lumen end (490A); said lumen (400A) extending axially through said core 200A forming a first bowl channel (420A) for inflowing said fluid (800) and said lumen (400A) having fluid communication with separation volume (220A) via trench (305A);

a bottom core (201A) having an outer wall (211A), a top surface (309A) contacting and connected with bottom surface (297A) of upper plate (299A) for rotation therewith; an upper bottom core end (206A), a lower bottom core end (296A), said top surface (309A) having an indentation (186A) and a trench (305A), and a lumen wall (324A) that has an upper wall end (324C) and a lower wall end (324B); said bottom core occupying a bottom coaxial volume of said interior volume (710A) of said outer housing (100A);

said upper wall end (324C) of lumen wall (324A) is adapted to engage with bottom wall end (325B) of inner lumen wall (325A) to form an inner lumen 400B having an upper lumen end (325C) and a lower lumen end (324B); said inner lumen (400B) forming a second bowl channel (410A) for removing a first separated fluid component (810);

a lower plate (300A) having a top surface (730A), a bottom surface (730B), and a hollow cylinder (320A) near center of lower plate (300A); said hollow cylinder (320A) has an opening (302A) adapted to engage with lower wall end (324B) of lumen (324A); and said lower plate (300A) having a circumference adapted to form a tight fit with the lower bottom core end (296A) for rotation therewith;

a connection sleeve having a sleeve flange surrounding a lumen mounting recess; said lumen mounting recess and top surface of lumen connector engaged to form a bowl chamber for removing a second separated fluid component; said connection sleeve further adapted to be secured to said apparatus near said housing outlet of said outer housing for rotation therewith.

7. The apparatus of claim 6 wherein said outer wall (210A) of said top core (200A)

- increases in diameter from said upper end (205A) to said lower end (295A).
8. The apparatus of claim 6 wherein said outer wall (211A) of said bottom core (201A) increases in diameter from said upper end (206A) to said lower end (296A).
  9. The apparatus of claim 6 wherein said outer wall (210A) of said top core (200A) increases in diameter from said upper end (205A) to said lower end (295A) and said outer wall (211A) of said bottom core (201A) increases in diameter from said upper end (206A) to said lower end (296A).
  10. The apparatus of claim 6 wherein lumen (400A) having a height (404A) and lumen wall (324A) having a height (324F) and the height (404A) of lumen (400A) is about one third to about four times the height (324F) of lumen wall (324A).
  11. The apparatus of claim 10 wherein the height (404A) of lumen (400A) and the height of lumen wall (324A) are about the same.
  12. The apparatus of claim 6 wherein the top surface (309A) of bottom core (201A) has one to 10 trenches (305A).
  13. The apparatus of claim 12 wherein the top surface (309A) of bottom core (201A) has three to six trenches (305A).
  14. The apparatus of claim 6 wherein said connection sleeve (500A) adapted to fluidly connect a first (420A) and second (410A) bowl channels, and a bowl chamber (740A) to a corresponding conduit channel (760A, 770A, and 780A) of an external conduit (20A).
  15. The apparatus of claim 6 wherein said outer housing (100A) comprises a locking mechanism adapted to secure said outer housing (100A) to a means (900) for rotating said apparatus (10A).
  16. The apparatus of claim 15 wherein said locking mechanism comprises protrusions

- (150A).
17. The apparatus of claim 16 wherein said locking mechanism comprises a key slot (160A).
  18. The apparatus of claim 6 wherein said lower plate (300A) is circular.
  19. The apparatus of claim 6 wherein said apparatus (10A) is adapted for use without a rotatable seal.
  20. The apparatus of claim 6 wherein said apparatus (10A) is closed to undesired contagions.
  21. The apparatus of claim 6 wherein said apparatus (10A) is adapted to allow rotation of said cores (200A, 201A), said lower plate (300A), said upper plate (299A), and said outer housing (100A) about said lumens (400A, 400B).
  22. The apparatus of claim 6 further comprising means (900) for rotating said outer housing (100A) about said axis (11).
  23. The apparatus of claim 22 wherein said means (900) for rotating comprises a bracket (910).
  24. The apparatus of claim 23 wherein said bracket (910) is adapted to engage and rotate an external conduit (20A) that is fluidly connected to said first bowl channel (420A), said second bowl channel (410A), and said bowl chamber (740A).
  25. The apparatus of claim 24 wherein said rotation means (900) is adapted to rotate said outer housing (100A) and said external conduit (20A) using 1-omega/2-omega spin technology.
  26. The apparatus of claim 22 further comprising:  
means (605) to remove said fluid (800) from a source (600), said means (605) to



remove said fluid (800) fluidly connected to said first bowl channel (420A);  
 means (607) to remove said first separated fluid component (810) via said second bowl channel (410A);  
 means (608) to remove said second separated fluid component (820) via said bowl chamber (740A); and  
 means (609) to treat said second separated fluid component (820) subsequent to being removed via bowl chamber (740A).

27. The apparatus of claim 26 further comprising means (606) to reinfuse treated second separated fluid component (820) and said first separated fluid component (810) back into said source (600), wherein said apparatus is a closed-loop apparatus when connected to said source (600).
28. The apparatus of claim 27 wherein said reinfusion means (606) comprises a needle or catheter.
29. The apparatus of claim 26 further comprising an anticoagulant source (615) fluidly connected between said means (605) to remove said fluid (800) from said source (600) and said first bowl channel (420A).
30. The apparatus of claim 26 wherein said means (605) to remove said fluid (800) from said source (600) comprises a needle or catheter (605).
31. The apparatus of claim 26 wherein said means (607) to remove said first separated fluid component (810) comprises a pump (617).
32. The apparatus of claim 26 wherein said treatment means (609) comprises a chamber and a source of ultraviolet radiation.
33. A connection sleeve (500A) for fluidly connecting an external conduit (20A) having a first conduit channel (780A) to a lumen (400A) of the centrifuge bowl (10A) having a first bowl channel (420A), said connection sleeve (500A) comprising;
 

a body (830A) having an upper sleeve end (831A) and a lower sleeve end (832A), said lower sleeve end (832A) adapted to be secured to said centrifuge bowl (10A); and

a sleeve wall (835A) adapted to receive and hold said external conduit (20A); said sleeve wall (835A) reinforced by one to four sleeve rings (833A);

a sleeve flange (790A) on said lower sleeve end (832A), said sleeve flange (790A) having a bottom surface (847A) and encircling a lumen mounting recess (851A) adapted to engage a lumen connector (481A) and outer housing outlet (700A) of said centrifuge bowl (10A).

34. The connection sleeve (500A) of claim 33 wherein said bottom surface (847A) further comprises protrusions (843A) for engaging lumen connector (481A).
35. The connection sleeve (500A) of claim 33 wherein said connection sleeve (500A) is adapted to be overmolded to said external conduit (20A).
36. The connection sleeve (500A) of claim 33 wherein said connection sleeve (500A) is made of a same material as external conduit (20A).
37. The connection sleeve (500A) of claim 33 wherein said lumen mounting recess (851A) and the top surface (482A) of lumen connector (481A)
38. An anchor sleeve (870A) for securing an external conduit (20A) having conduit channels (760A, 770A, 780A) to a restraint (918A), said anchor sleeve (870A) comprising: a body (870A) having a first anchor end (873A) and a second anchor end (874A); a plurality of longitudinal ribs (877A) in parallel with said conduit channels, said longitudinal ribs having first rib ends (877B) and second rib ends (877C) said second rib ends (877C) extending beyond the first anchor end (873A).
39. An anchor sleeve of claim 38 wherein the number of longitudinal ribs is three.
40. A conduit assembly (860A) for fluidly connecting a source (600) of fluid (800) to a centrifuge bowl (10A) comprising:  
an external conduit (20A) of approximately constant diameter having a first conduit end (861A) and a second conduit end (862A);  
a connection sleeve (500A) secured to said first conduit end (861A), said connection sleeve (500A) adapted to fluidly connect to said centrifuge bowl (10A);

an anchor sleeve (870A) secured to said second conduit end (862A);  
 a first bearing ring (871A) surrounding said external conduit (20A) and positioned between said connection sleeve (500A) and said anchor sleeve (870A), said first bearing ring (871A) adapted to engage a means (900) for rotating said centrifuge bowl (10A); and  
 a first assembly channel (990A), a second assembly channel (991A), and a third assembly channel (992A) extending through said conduit assembly (860A).

41. The conduit assembly (860A) of claim 40 wherein said connection sleeve (500A) and said anchor sleeve (870A) are overmolded to said external conduit (20A).

42. The conduit assembly (860A) of claim 40 wherein:

said anchor sleeve (870A) has a first anchor end (873A) and a second anchor end (874A), said first anchor end (873A) being secured to said external conduit (20A), said anchor sleeve (870A) increasing in diameter from said first anchor end (873A) to said second anchor end (874A);

said connection sleeve (500A) has an upper sleeve end (831A) and a lower sleeve end (832A), said upper sleeve end (831A) being secured to said external conduit (20A), said connection sleeve (500A) increasing in diameter from said upper sleeve end (831A) to said lower sleeve end (832A); and

said anchor sleeve (870A), connection sleeve (500A), and external conduit (20A) are made of the composition.

43. The conduit assembly (860A) of claim 40 wherein said connection sleeve (500A) comprises a sleeve flange (790A).

44. The conduit assembly (860A) of claim 40 further comprising a second bearing ring (872A) surrounding said conduit (20A) and positioned between said first bearing ring (871A) and said anchor sleeve (870A), said second bearing ring (872A) adapted to engage a means (900) for rotating said centrifuge bowl (10A).

45. The conduit assembly (860A) of claim 40 wherein said first and second bearing rings (871A, 872A) are 7.5 to 9.5 inches apart.
46. The conduit assembly (860A) of claim 45 wherein said first bearing ring (871A) is 5.0 to 5.5 inches from a lower end (832A) of said connection sleeve (500A).
47. A method for separating components of a fluid (800) comprising a higher density component (810) and a lower density component (820), the method comprising:  
providing a centrifuge bowl (10A) comprising a first bowl channel (420A), a second bowl channel (410A), and a bowl chamber (740A);  
flowing said fluid (800) from a source (600) into said centrifuge bowl (10A) through said first bowl channel (420A);  
rotating said centrifuge bowl (10A) about an axis (11);  
removing said higher density component (810) from said bowl (10A) via said second bowl channel (410A); and  
removing said lower density component (820) from said bowl (10A) via said bowl chamber (740A).
48. The method of claim 47 wherein said centrifuge bowl (10) further comprises:  
  
an outer housing (100A) with an upper housing end (110A) and a lower housing end (190A), wherein said outer housing (100A) increases in diameter from said upper housing end (110A) to said lower housing end (190A), said lower housing end (190A) having a housing floor (180A) and said housing upper end (110A) having a housing outlet (700A), said outer housing (100A) having an interior volume (710A) and adapted for rotation about a center axis (11);  
  
a top core (200A) having an outer wall (210A), an upper top core end (205A), and a lower top core end (295A); said top core (200A) connected with said outer housing (100A) for rotation therewith; occupying a top coaxial volume of said interior volume (710A) of said outer housing (100A); and providing a top separation volume (220A) between said top core (200A) and said outer housing (100A);

said upper top core end (205A) having a lumen connector (481A); said lumen connector (481A) having a first lumen wall (401A) extending downward from the a top surface (482A) of the lumen connector (481A); said lumen connector (481A) further having an inner lumen wall (325A) within said first lumen wall (401A) and extending downward from the top surface (482A); said inner lumen wall having a top wall end (325C) and a bottom wall end (325B);

an upper plate (299A) having a top surface (298A), a bottom surface (297A), a second lumen wall (402A) extending above said top surface (298A); said upper plate (299A) having a circumference adapted to form a tight fit with the lower top core end (295A) for rotation therewith;

said second lumen wall (402A) adapted to overlap with said first lumen wall (401A) to form a lumen (400A) having an upper lumen end (480A) and a lower lumen end (490A); said lumen (400A) forming a first bowl channel (420A) for inflowing said fluid (800) and extending axially through said core 200A leading to indentation (186A) and trenches (305A);

a bottom core (201A) having an outer wall (211A), a top surface (309A) contacting and connected with bottom surface (297A) of upper plate (299A) for rotation therewith; an upper bottom core end (206A), a lower bottom core end (296A), a top surface (309A) having an indentation (186A) and a trench (305A), and a lumen wall (324A) that has an upper wall end (324C) and a lower wall end (324B); said bottom core occupying a bottom coaxial volume of said interior volume (710A) of said outer housing (100A) and providing a bottom separation volume (220B) between said bottom core (201B) and said outer housing (100A);

said upper wall end (324C) of lumen wall (324A) is adapted to engage with bottom wall end (325B) of inner lumen wall (325A) to form a second bowl channel (410A) for removing a first separated fluid component (810); said top surface (309A) is adapted to engage with the bottom surface 297A of the upper plate (299A);

a lower plate (300A) having a top surface (730A), a bottom surface (730B), and a hollow cylinder (320A) near center of lower plate (300A); said hollow cylinder (320A) has an opening (302A) adapted to engage with lower wall end (324B) of lumen (324A); and said lower plate (300A) having a circumference adapted to form a tight fit with the lower bottom core end (296A) for rotation therewith;

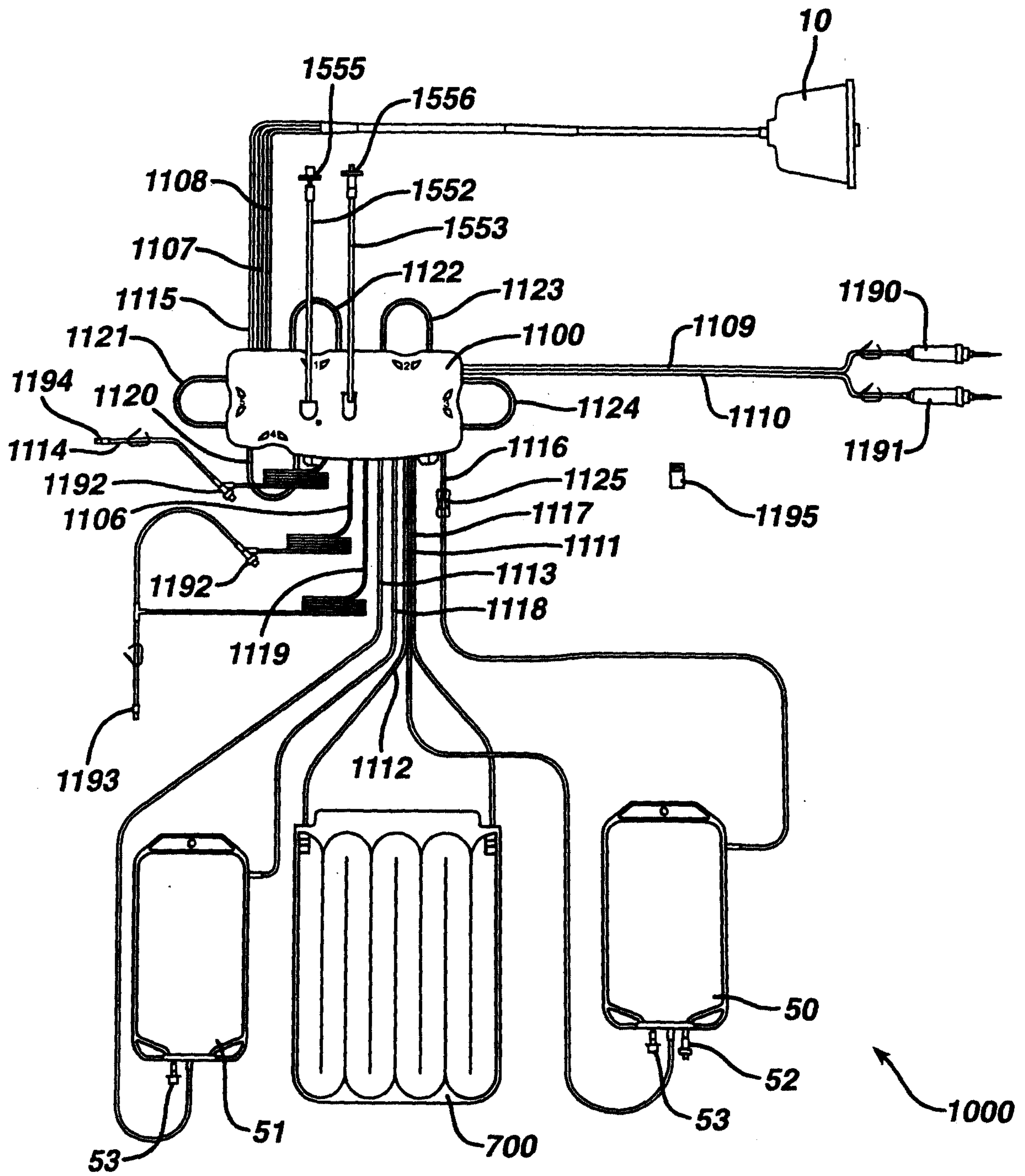
a connection sleeve (500A) having a sleeve flange (790A) surrounding a lumen mounting recess (851A); said lumen mounting recess (851A) and top surface (482A) of lumen connector (481A) engaged to form the bowl chamber (740A) for removing a second separated fluid component (820); said connection sleeve (500A) further adapted to be secured to said apparatus (10A) near said housing outlet (700A) of said outer housing (100A) for rotation therewith.

49. The method of claim 47 wherein said step of removing said first separated fluid component (810) comprises applying negative pressure to said second bowl channel (410A).
50. The method of claim 47 wherein said negative pressure is applied by a pump (617).
51. The method of claim 50 wherein said pump (617) provides substantially stable flow.
52. The method of claim 47 wherein said step of removing said first separated fluid component (810) comprises applying positive pressure to said centrifuge bowl (10A).
53. The method of claim 47 wherein said fluid (800) comprises a biological fluid.
54. The method of claim 53 wherein said biological fluid comprises blood.
55. The method of claim 54 wherein said higher density component (810) comprises red blood cells and said lower density component (820) comprises a buffy coat.
56. The method of claim 55 further comprising the step of collecting platelets from said lower density component (820).
57. The method of claim 55 further comprising the step of reinfusing said higher density component (810) into said source (600).
58. The method of claim 55 further comprising: treating said lower density component (820); and reinfusing said treated lower density component (820) into said source (600) to treat, ameliorate, prevent, or delay the onset of white blood cell or T-cell mediated diseases.
59. The method of claim 58 wherein said method is completed in less than 70 minutes.

60. The method of claim 58 wherein said white blood cell and T-cell mediated diseases are selected from the group consisting of cancer, T-cell lymphoma, Graft-versus-Host disease, Rheumatoid Arthritis, Progressive Systemic Sclerosis, Juvenile Onset Diabetes, Inflammatory Bowel Disease, Alopecia Areata, Ankylosing Spondylitis, Antiphospholipid Syndrome, Autoimmune Addison's Disease, Autoimmune Hemolytic Anemia, Autoimmune Hepatitis, Behcet's Disease, Bullous Pemphigoid, Cardiomyopathy, Celiac Sprue-Dermatitis, Chronic Fatigue Immune Dysfunction Syndrome, Chronic Inflammatory Demyelinating Polyneuropathy, Churg-Strauss Syndrome, Cicatricial Pemphigoid, CREST Syndrome, Cold Agglutinin Disease, Crohn's Disease, Discoid Lupus, Essential Mixed Cryoglobulinemia, Fibromyalgia-Fibromyositis, Graves' Disease, Guillain-Barré Syndrome, Hashimoto's Thyroiditis, Idiopathic Pulmonary Fibrosis, Idiopathic Thrombocytopenia Purpura, IgA Nephropathy, Insulin Dependent Diabetes, Juvenile Arthritis, Lichen Planus, Ménière's Disease, Mixed Connective Tissue Disease, Multiple Sclerosis, Myasthenia Gravis, Pemphigus Vulgaris, Pernicious Anemia, Polyarteritis Nodosa, Polychondritis, Polyglandular Syndromes, Polymyalgia Rheumatica, Polymyositis and Dermatomyositis, Primary Agammaglobulinemia, Primary Biliary Cirrhosis, Psoriasis, Raynaud's Phenomenon, Reiter's Syndrome, Rheumatic Fever, Rheumatoid Arthritis, Sarcoidosis, Scleroderma, Sjögren's Syndrome, Stiff-Man Syndrome, Systemic Lupus Erythematosus, Takayasu Arteritis, Temporal Arteritis/Giant Cell Arteritis, Ulcerative Colitis, Uveitis, Vasculitis, Vitiligo, and Wegener's Granulomatosis.
61. The method of claim 58 further comprising ameliorating or preventing organ or tissue transplant rejection.
62. The system of claim 58 wherein said treatment step comprises irradiating said lower density component (820).
63. The method of claim 58 wherein said treatment step is performed so as to induce apoptosis within said lower density component (820).
64. The method of claim 58 wherein said method is performed continuously without the need to batch process said fluid (800).

1/51

**FIG. 1**





**FIG. 2**

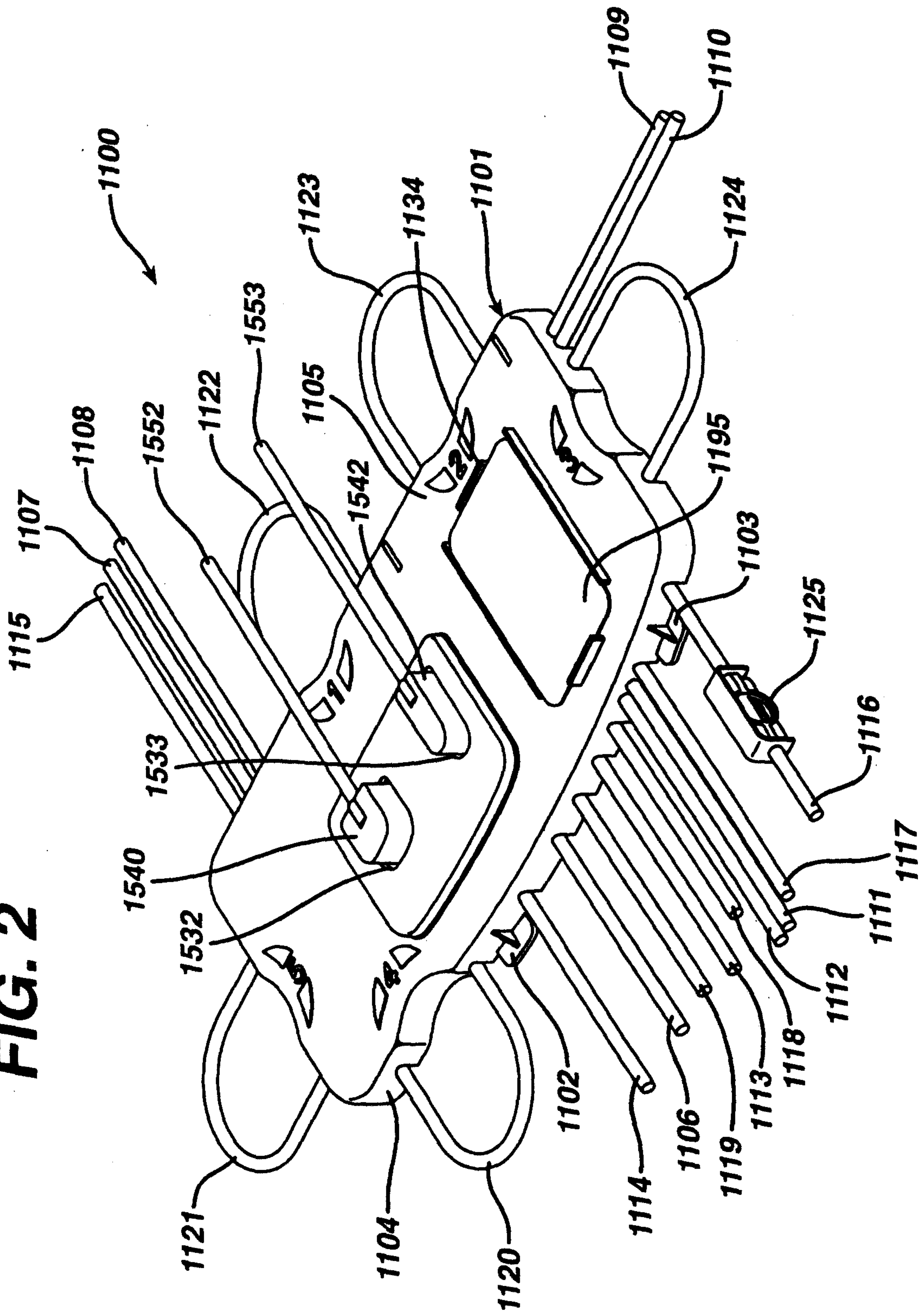
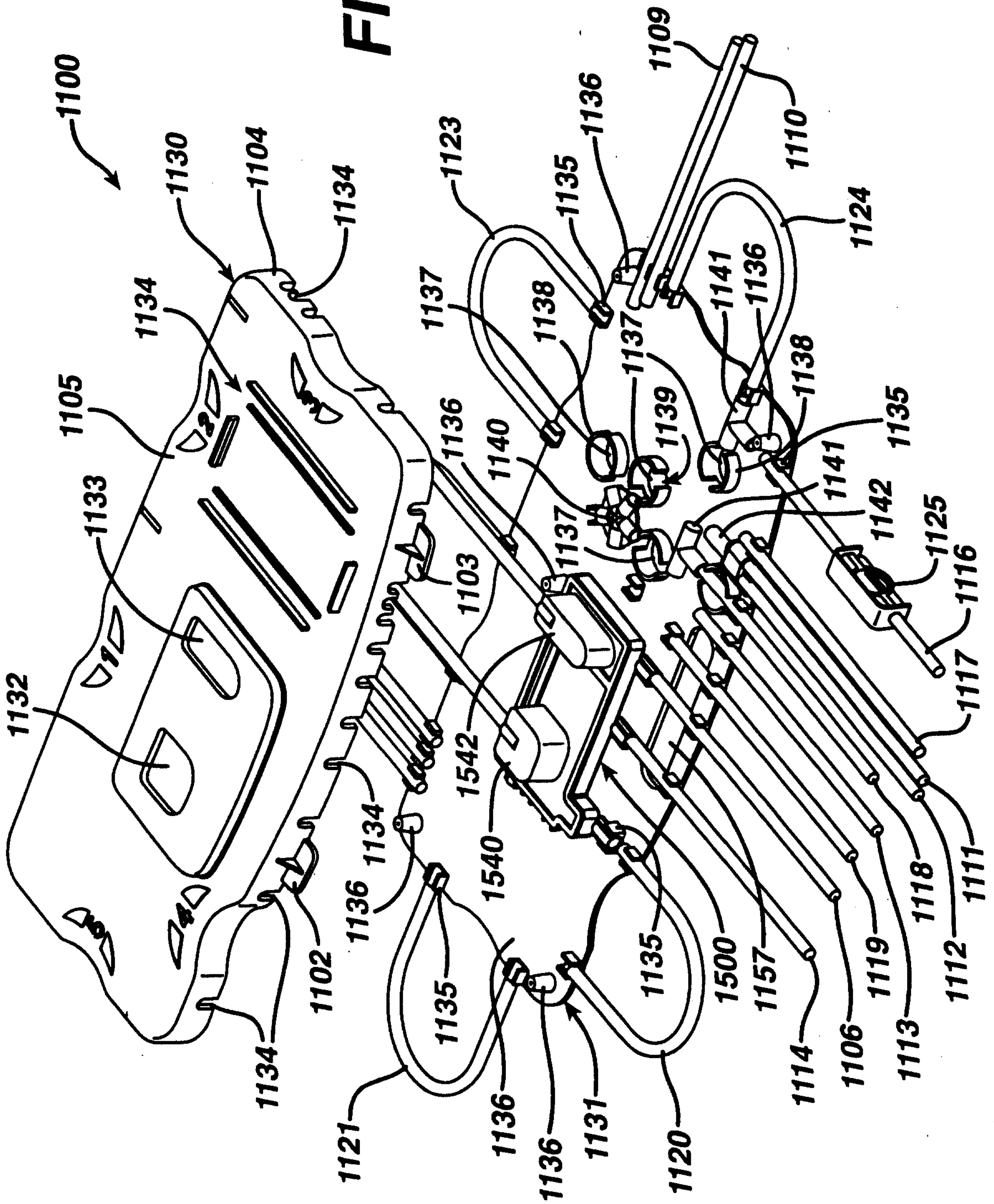
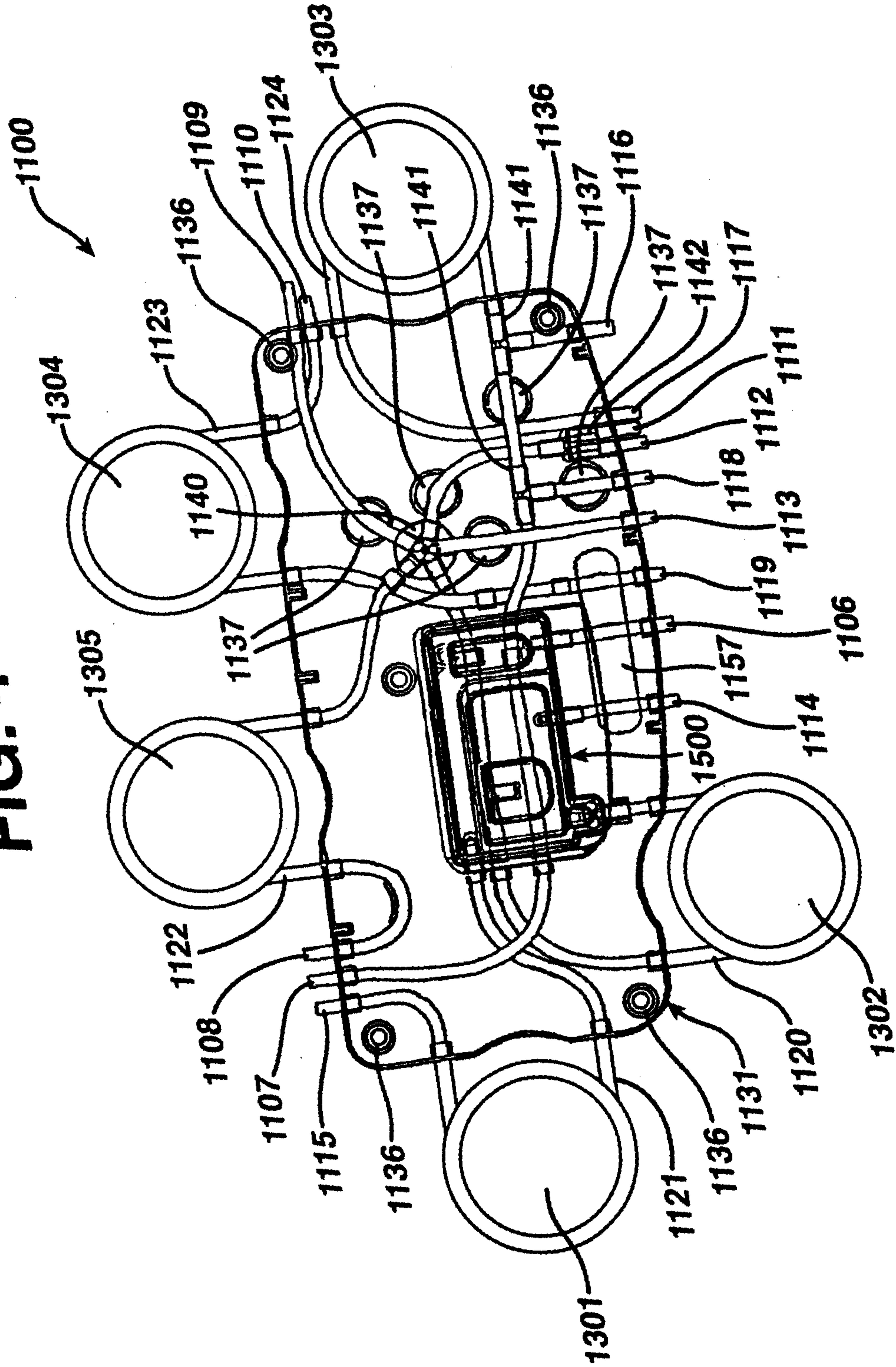


FIG. 3

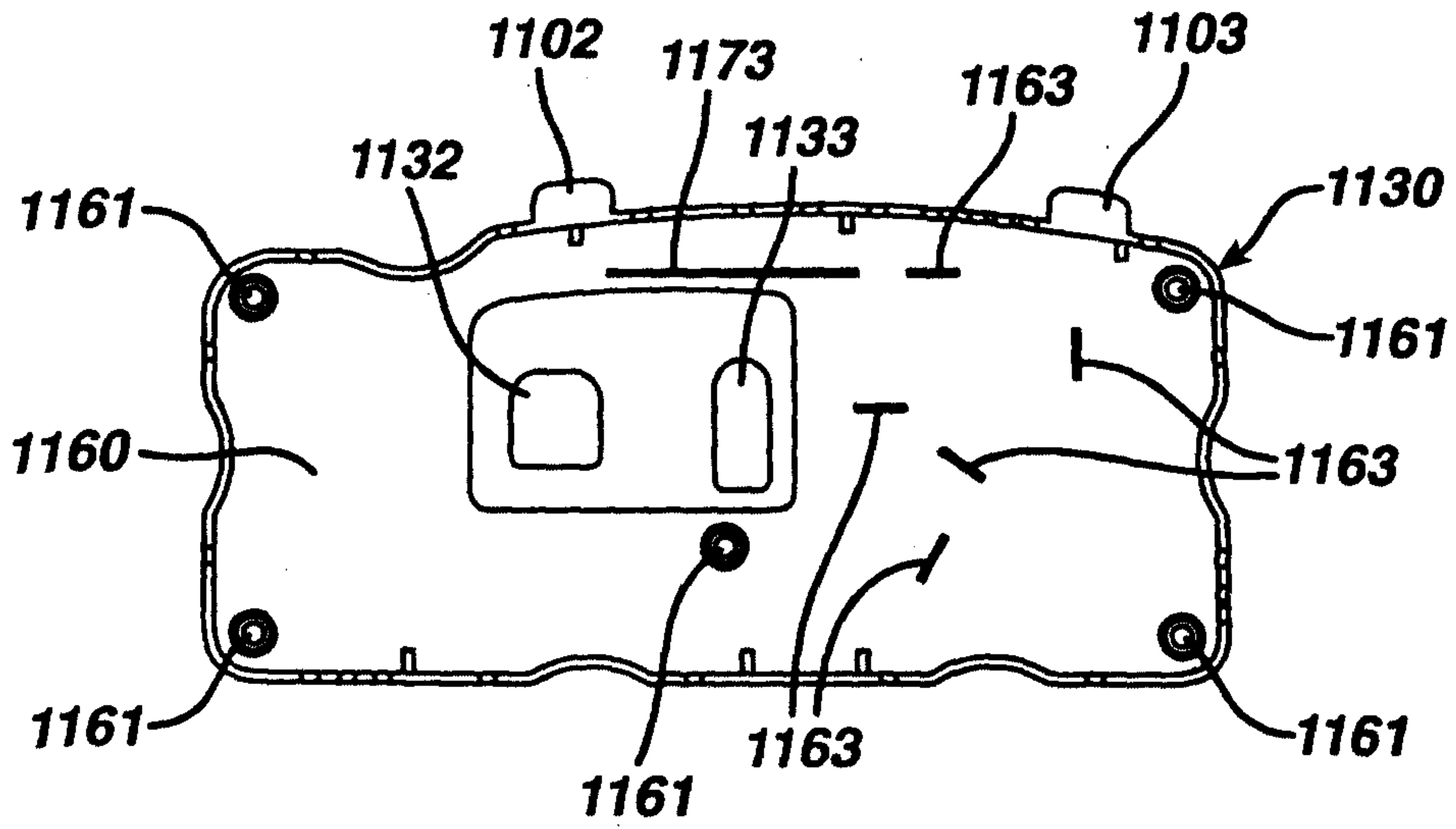


**FIG. 4**



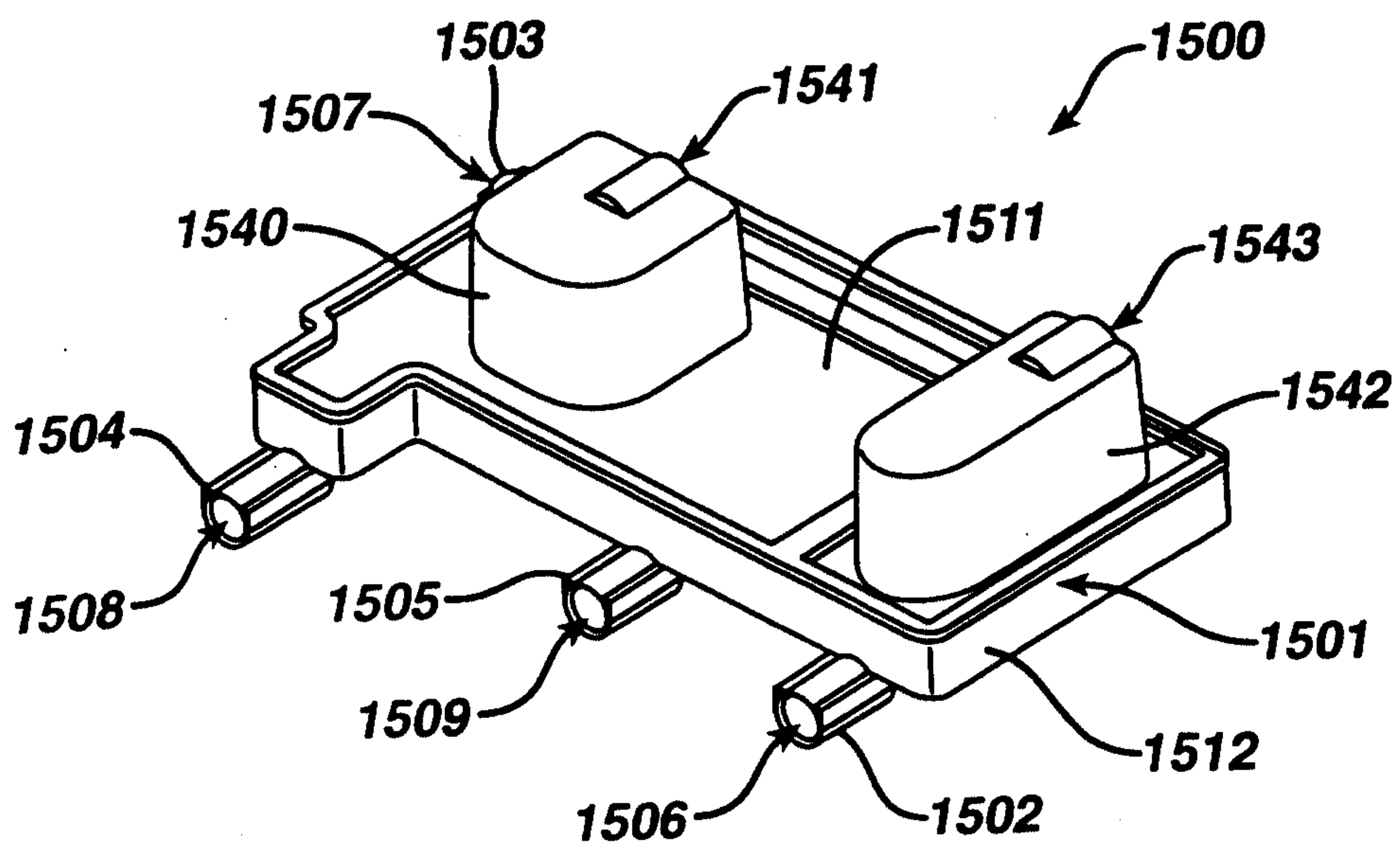
5/51

**FIG. 5**



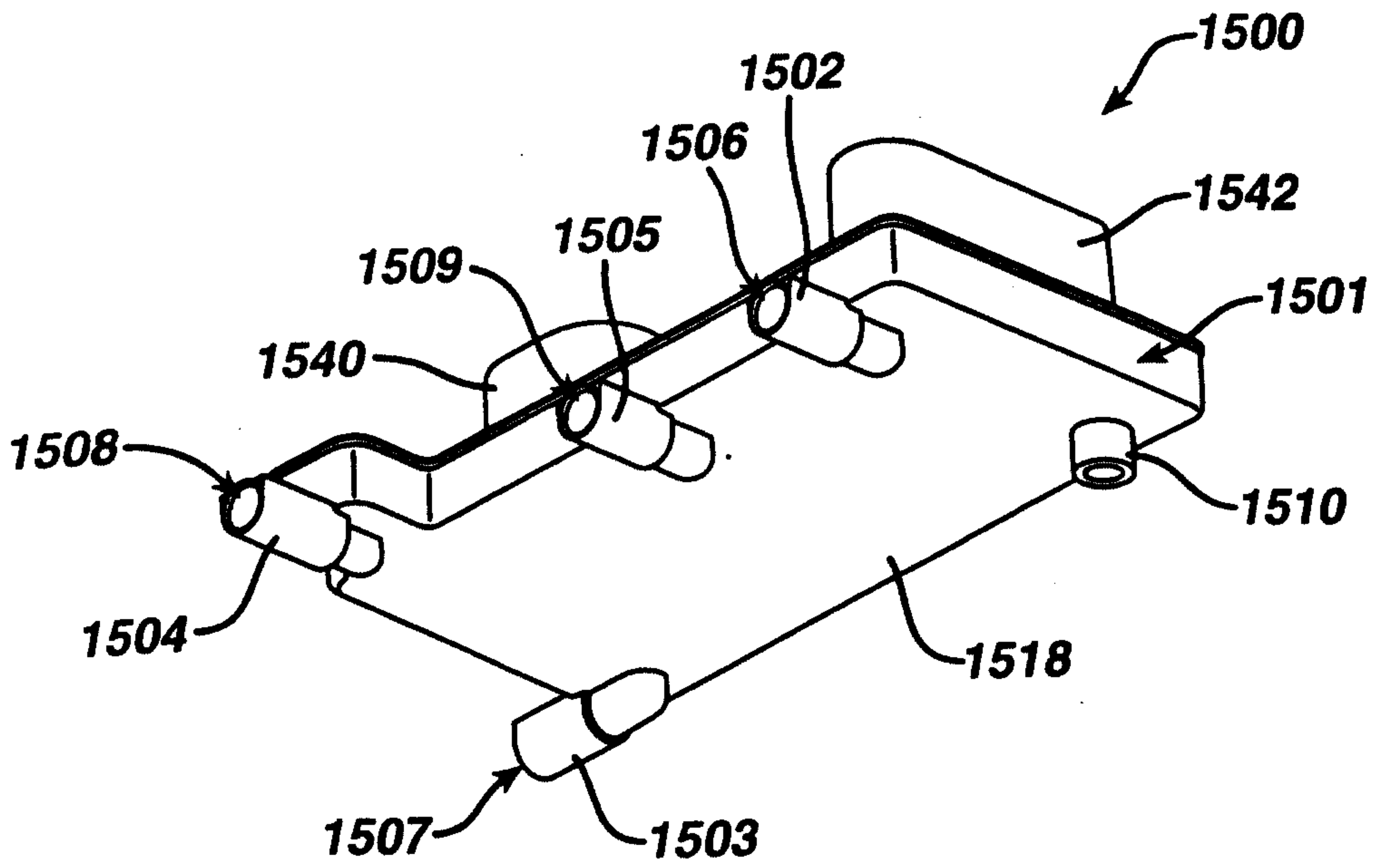
6/51

**FIG. 6**



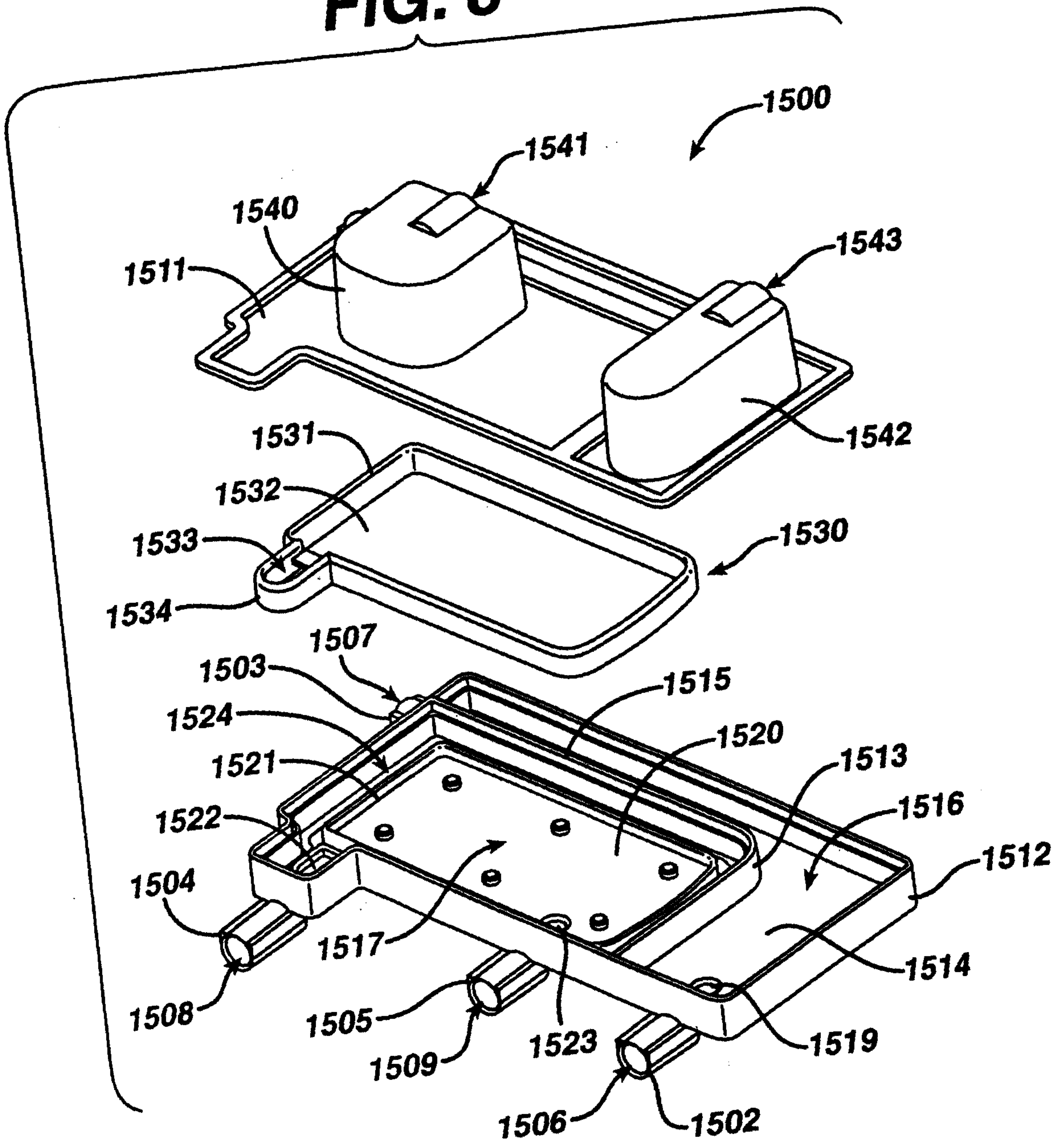
7/51

**FIG. 7**



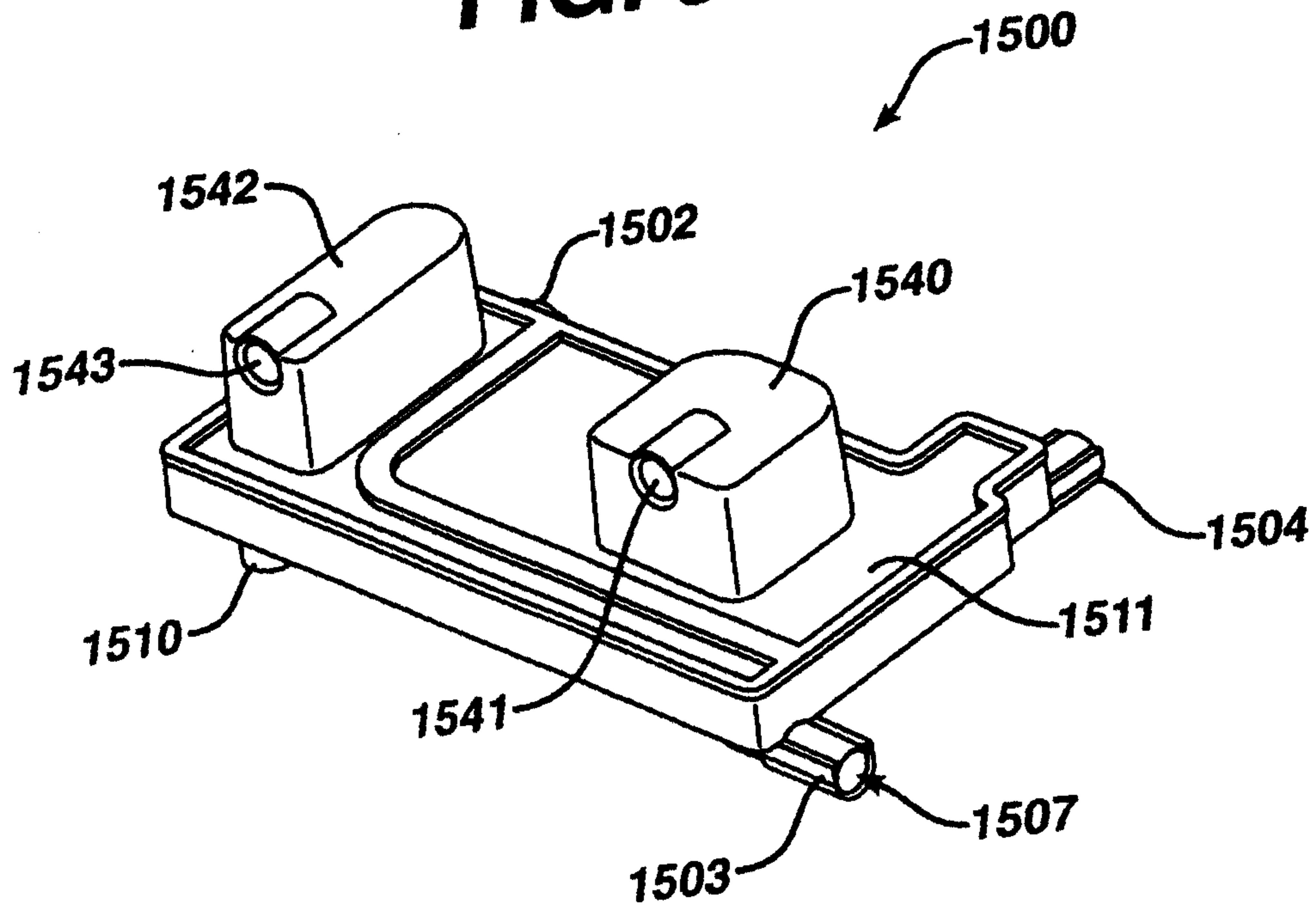
8/51

**FIG. 8**



9/51

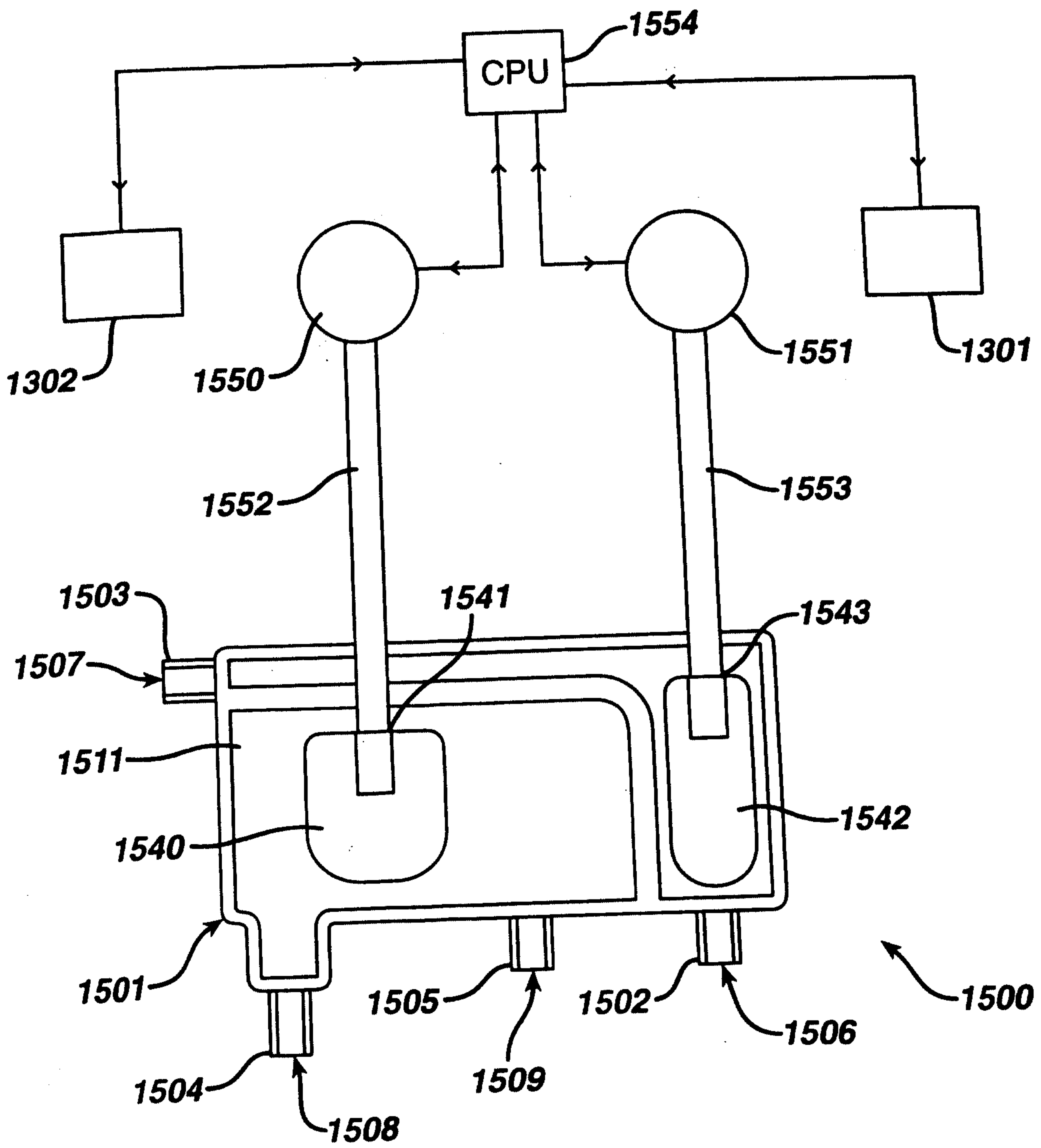
**FIG. 9**





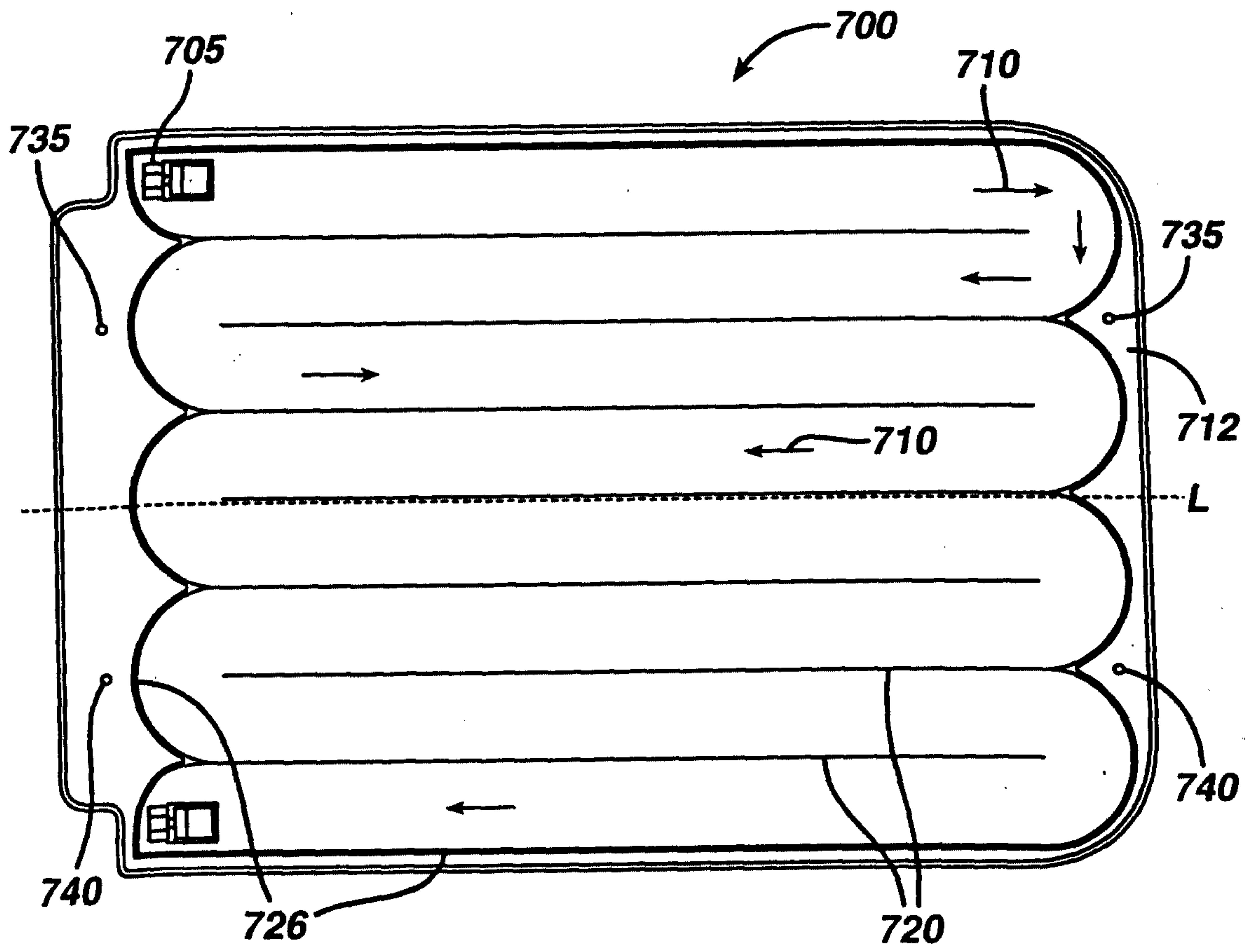
10/51

**FIG. 10**



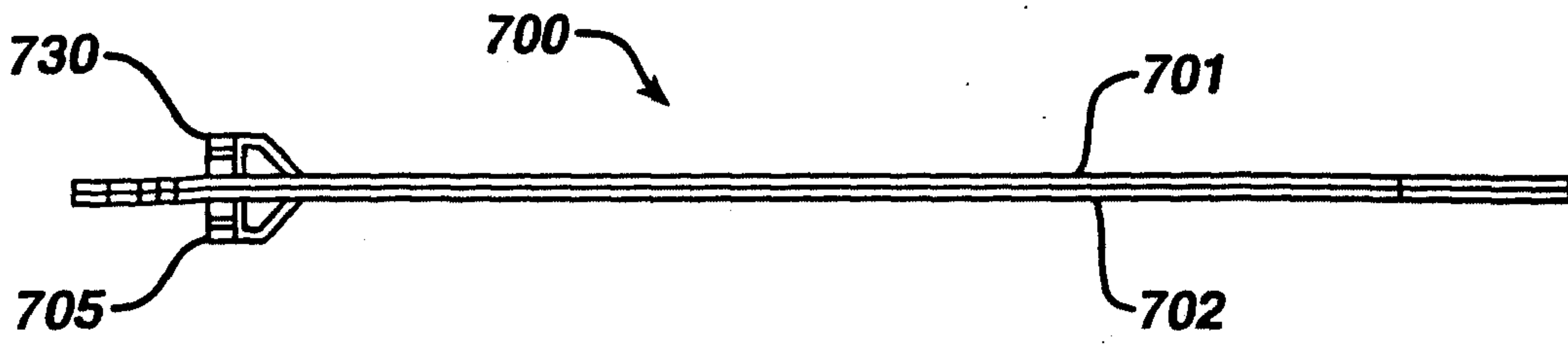
11/51

**FIG. 11**

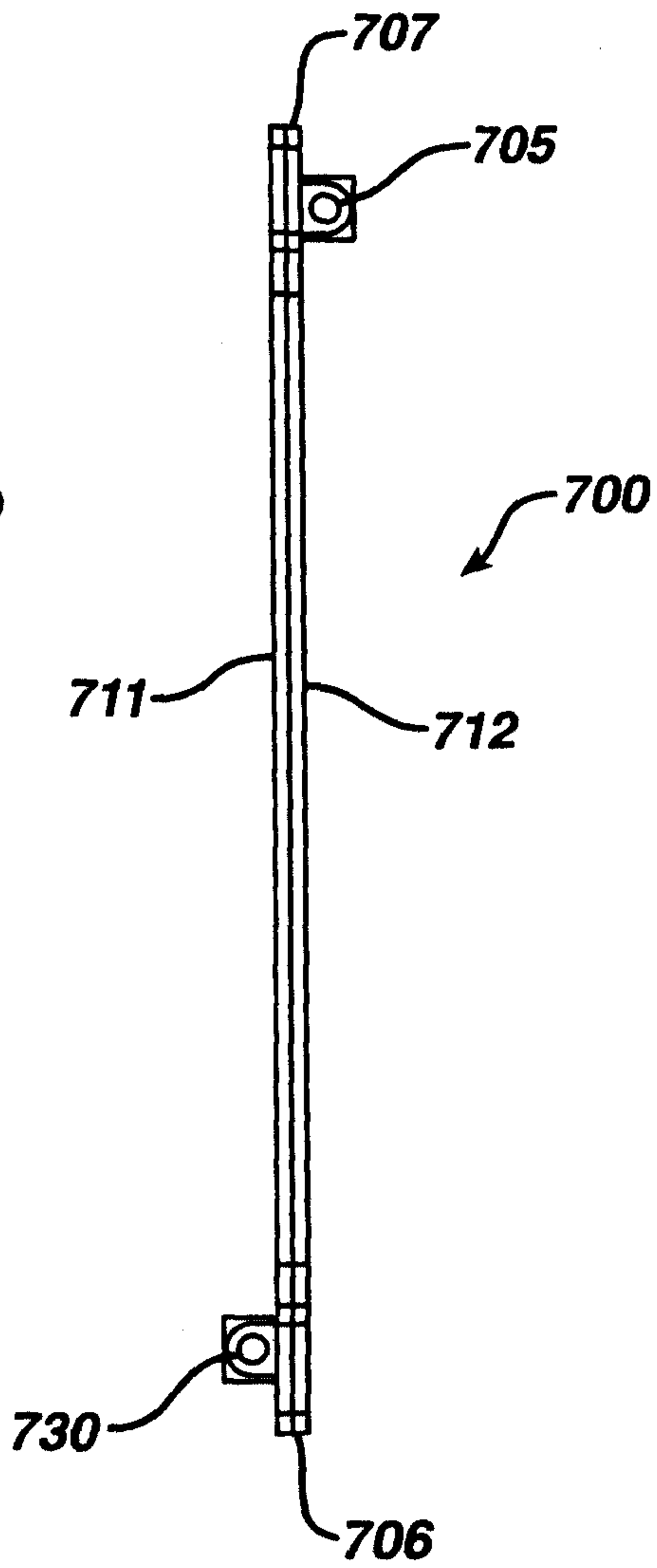


12/51

**FIG. 12**

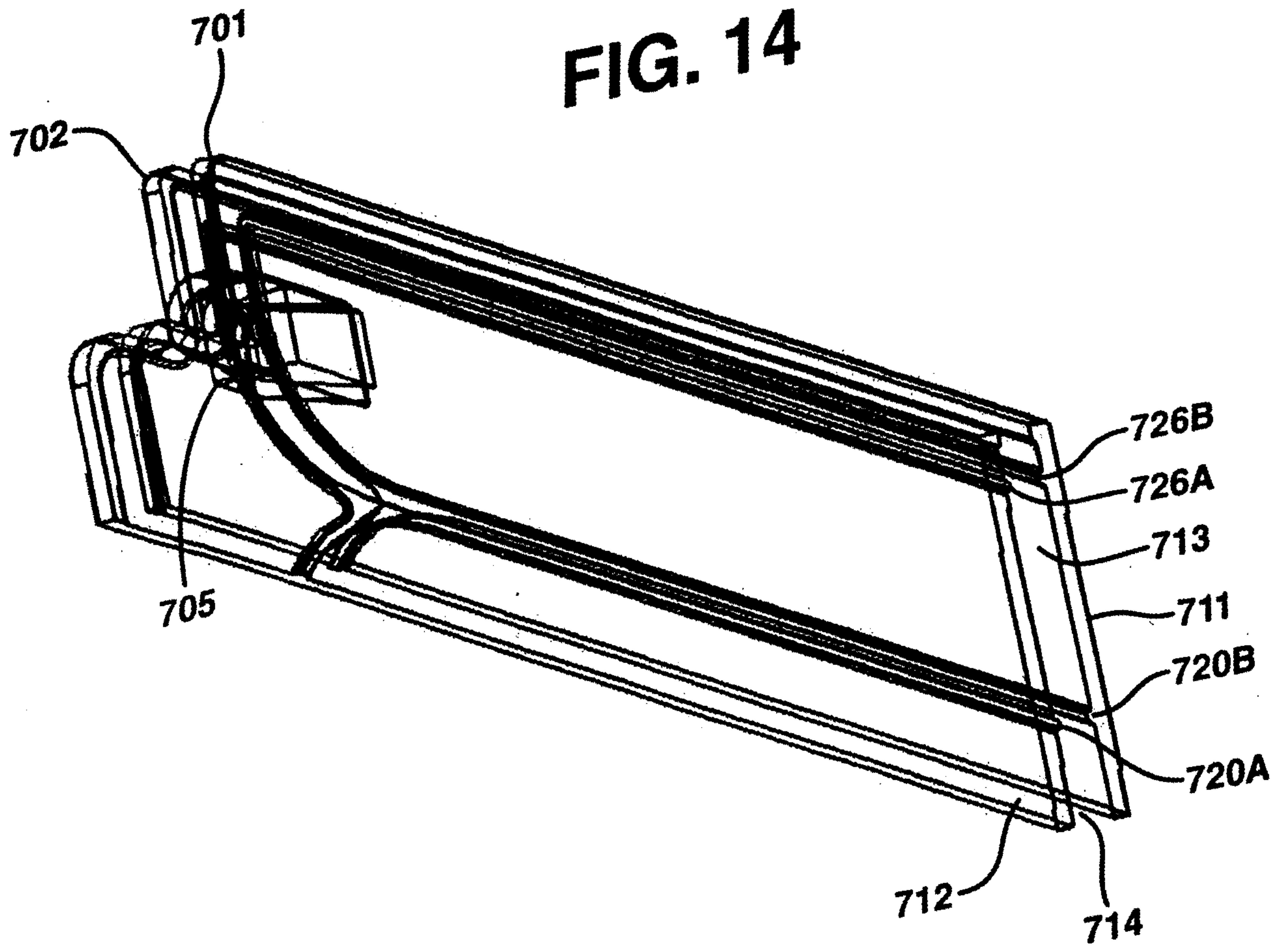


**FIG. 13**



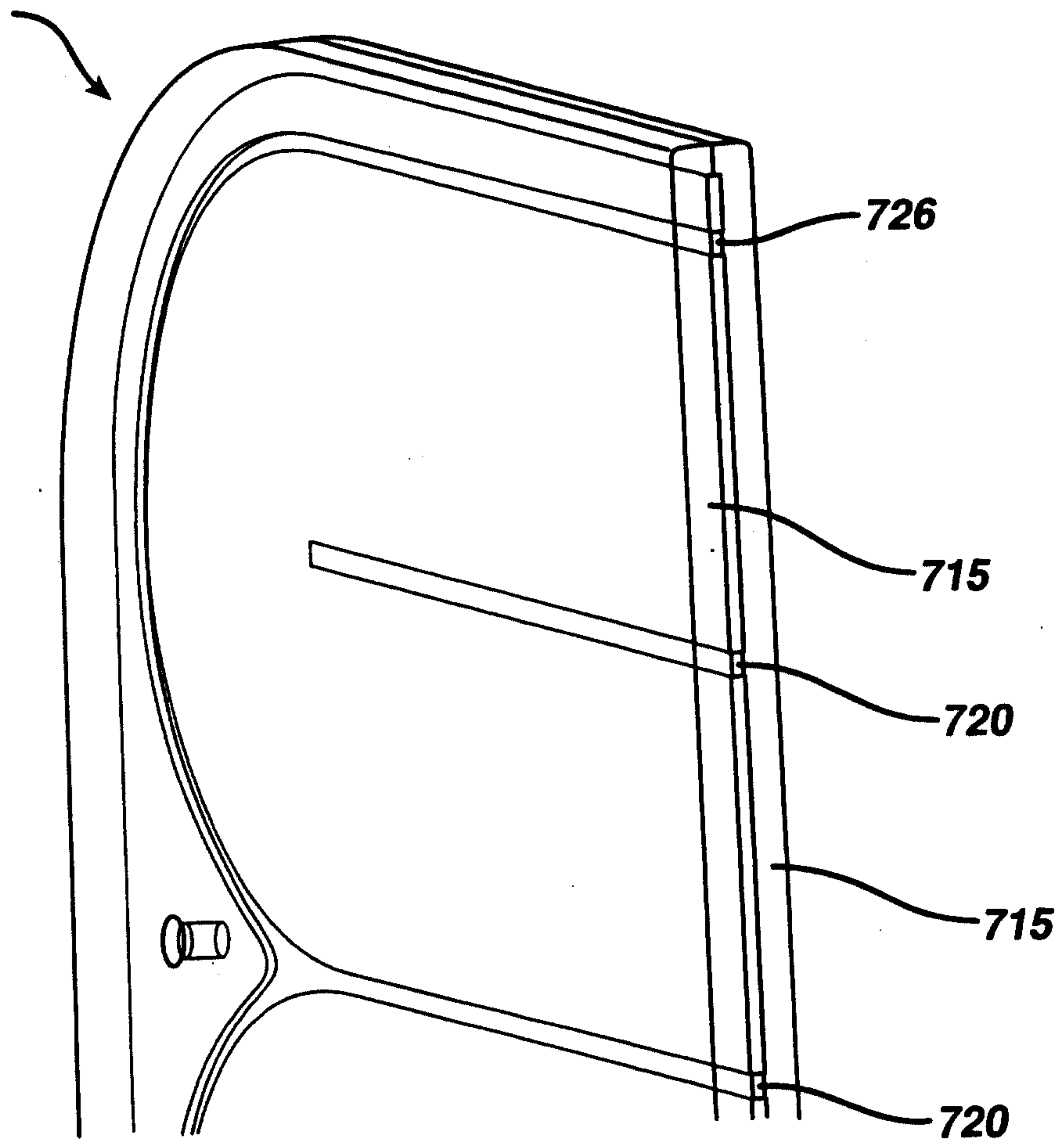
13/51

FIG. 14



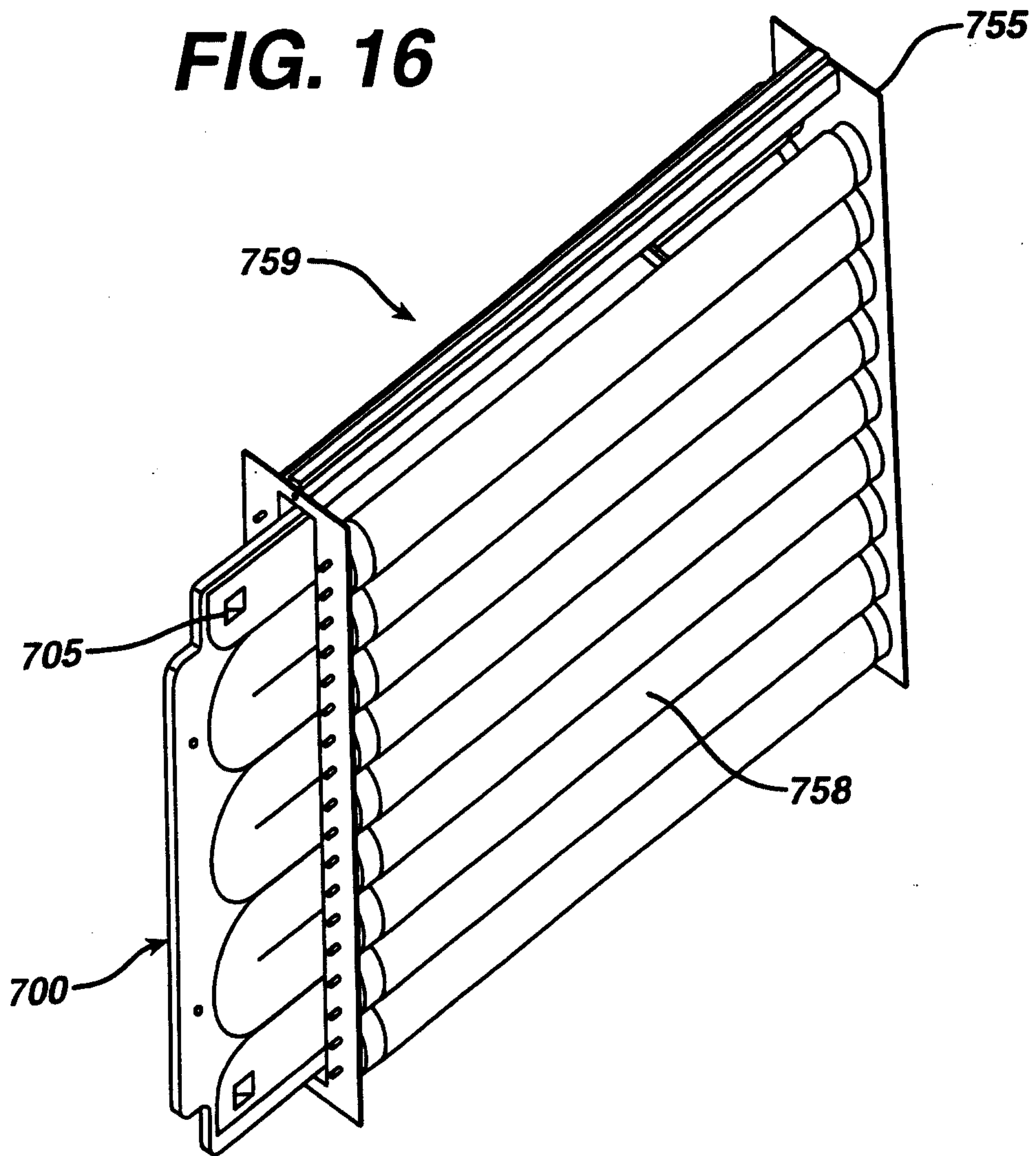
14/51

**FIG. 15**



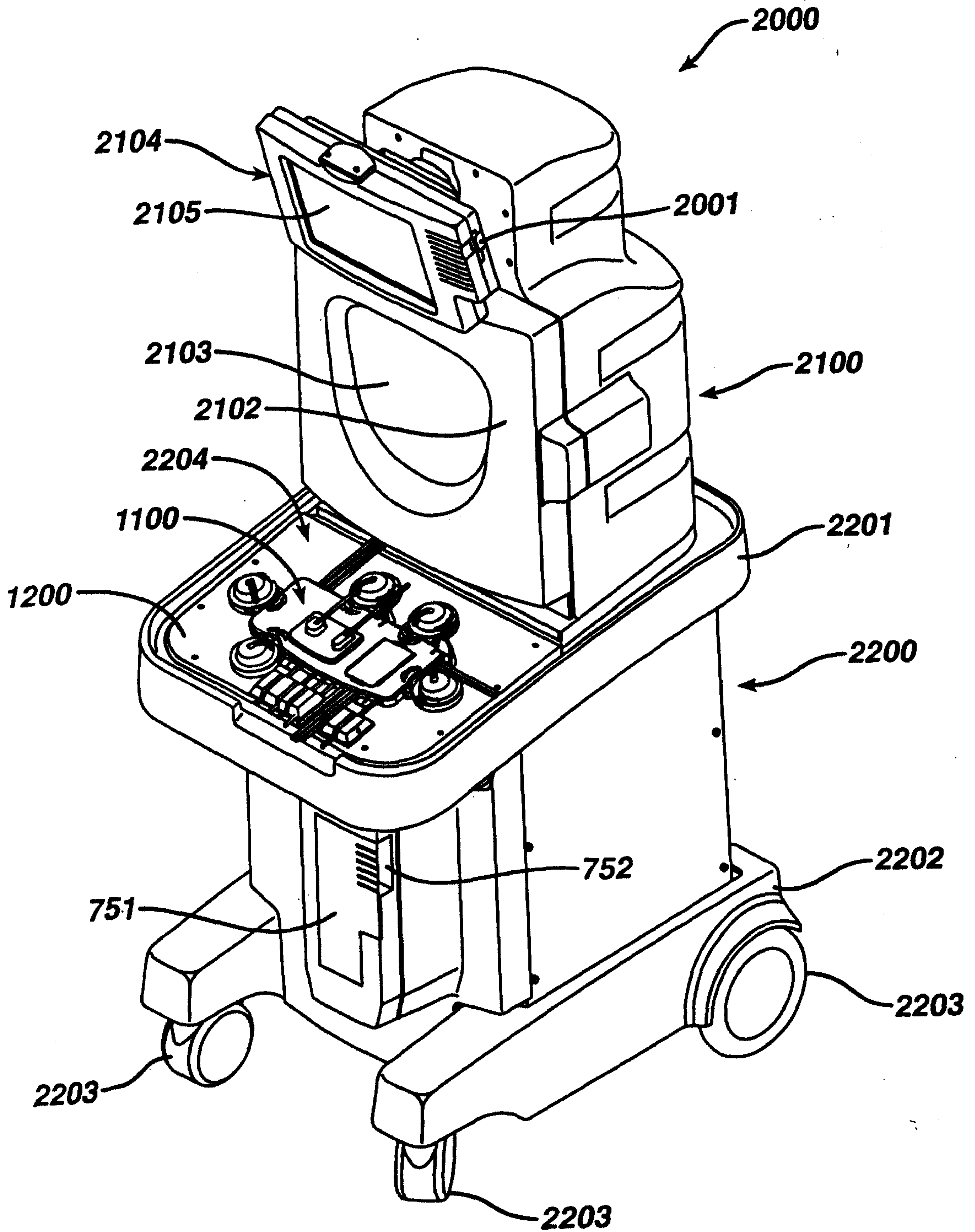
15/51

**FIG. 16**



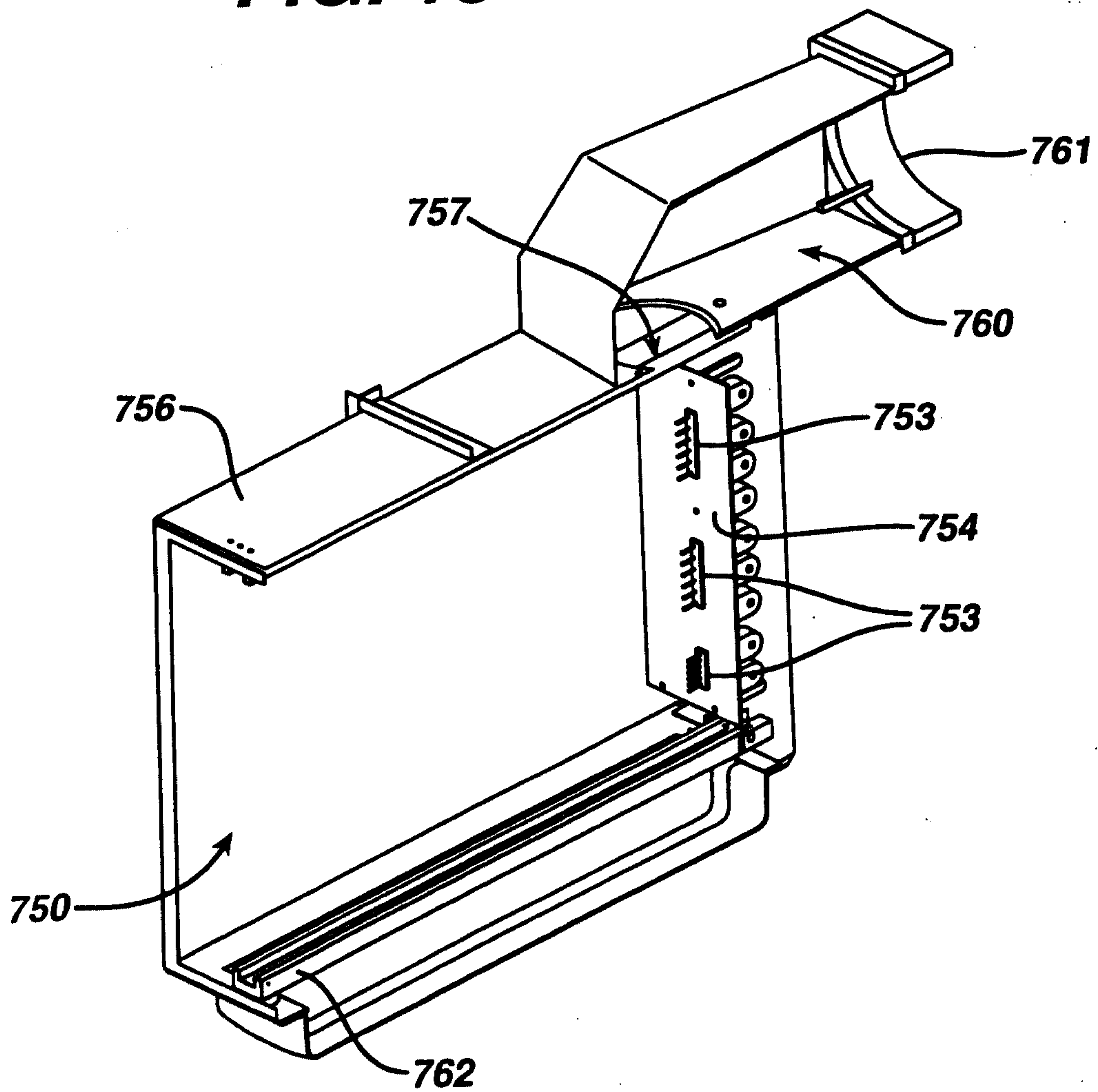
16/51

**FIG. 17**



17/51

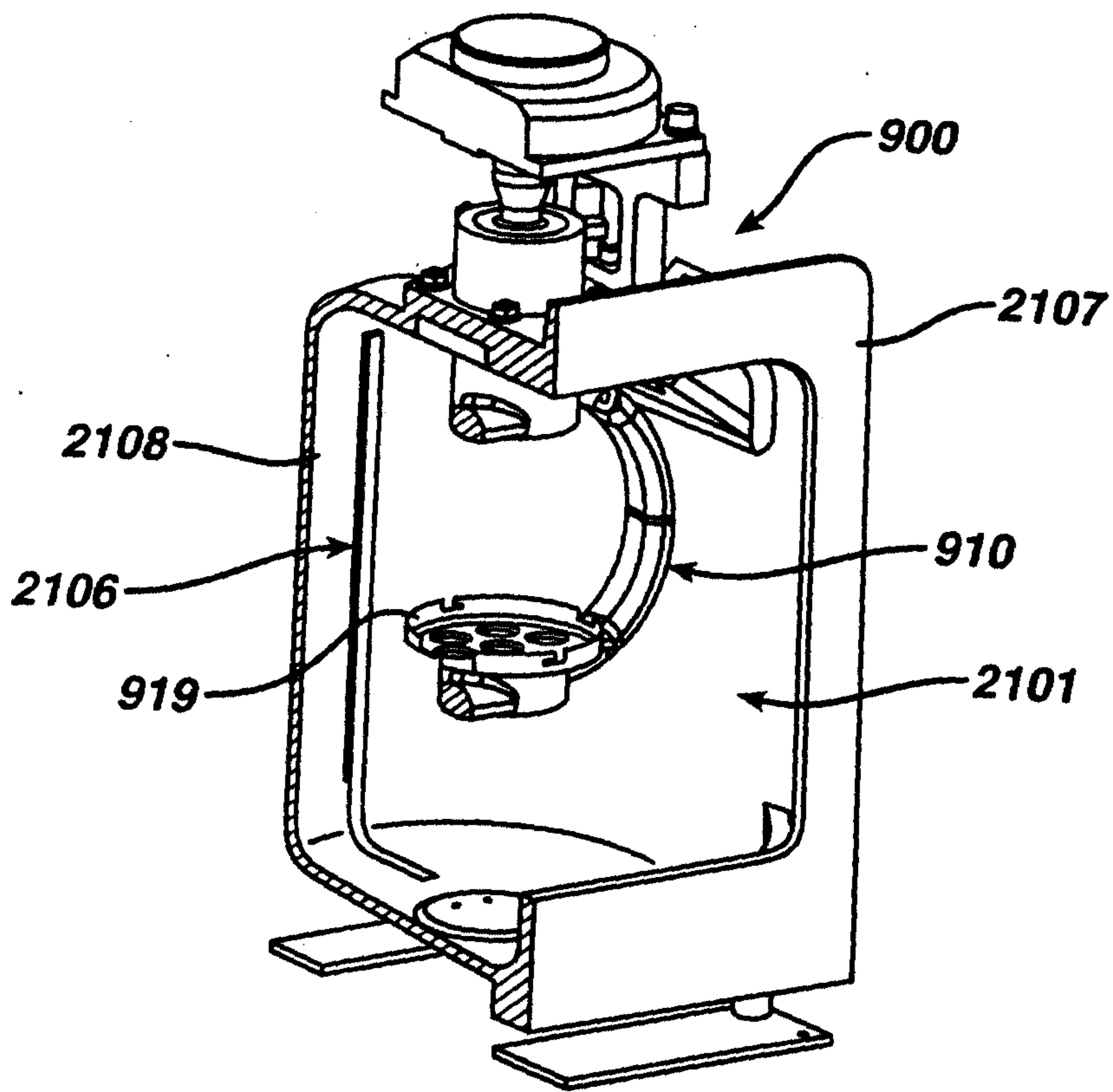
**FIG. 18**





18/51

**FIG. 19**



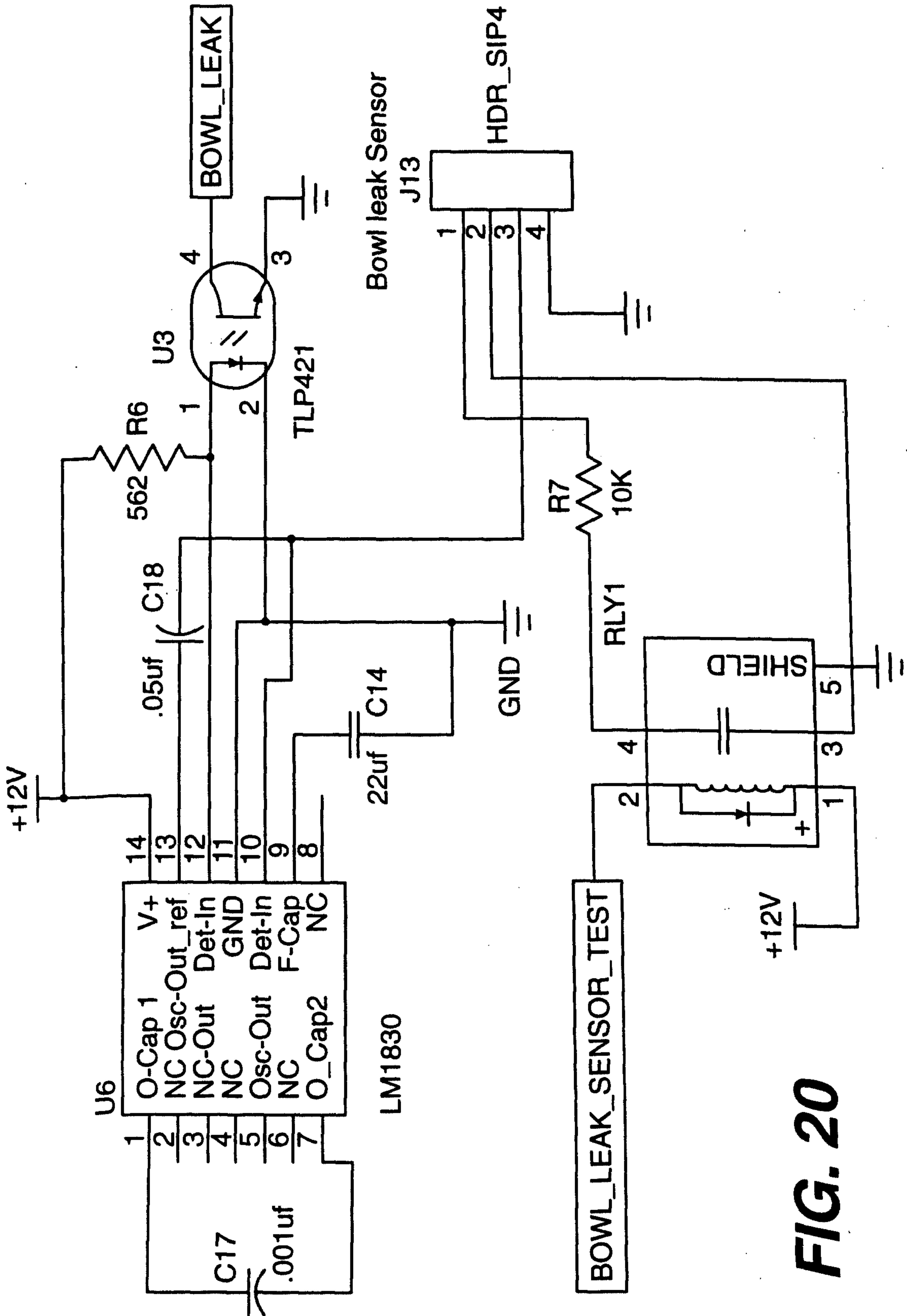
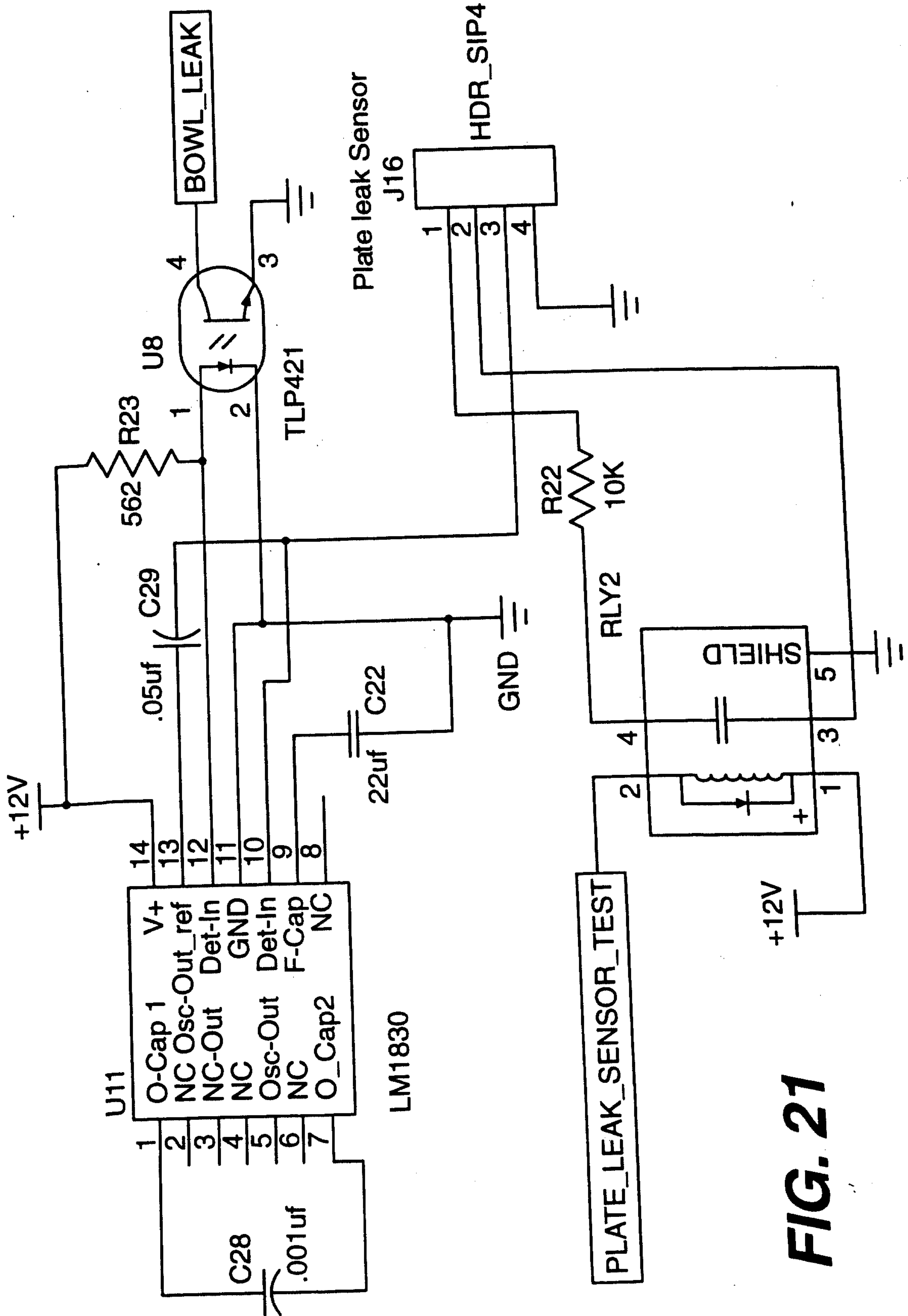


FIG. 20

20/51



**FIG. 21**

21/51

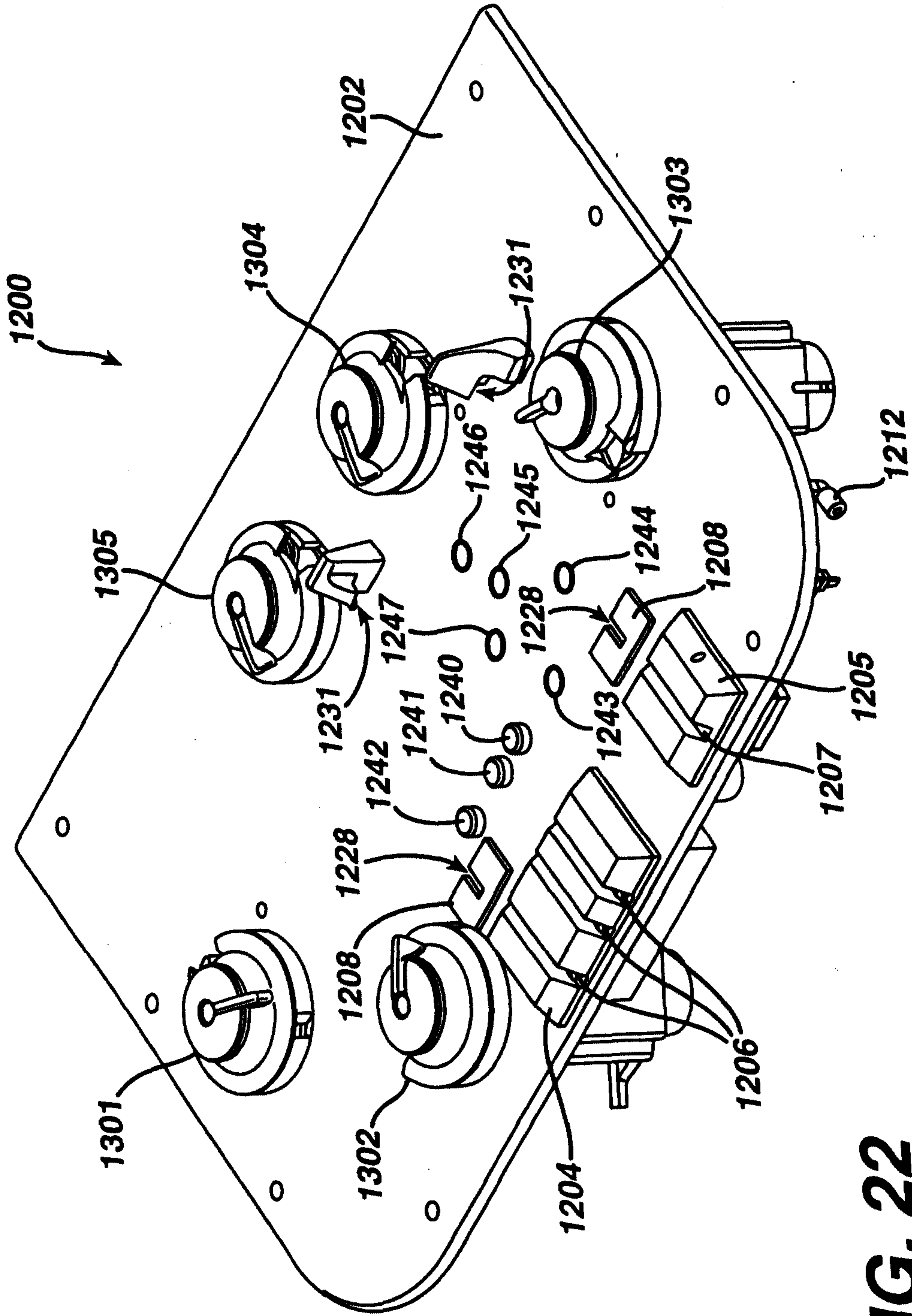
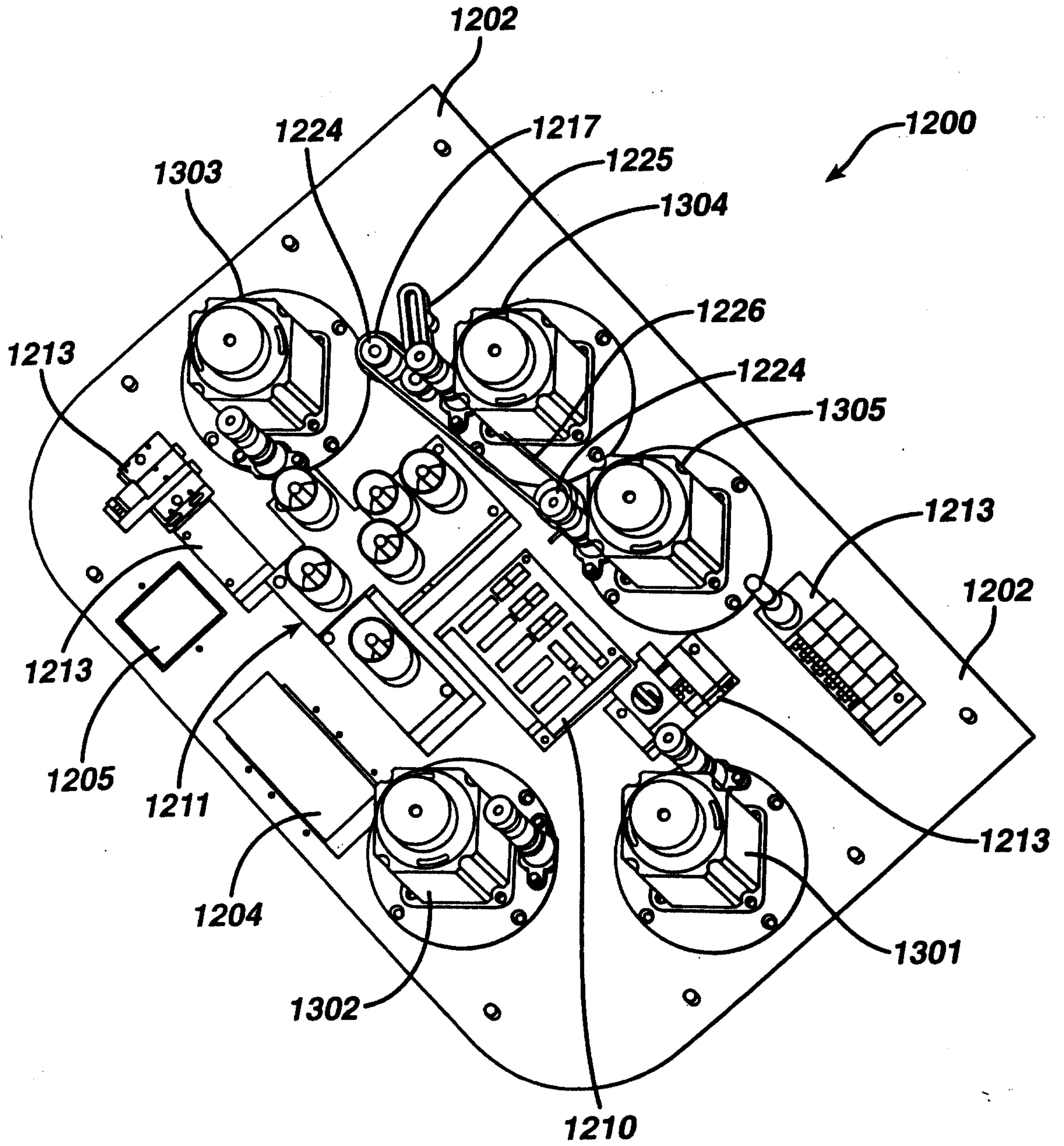


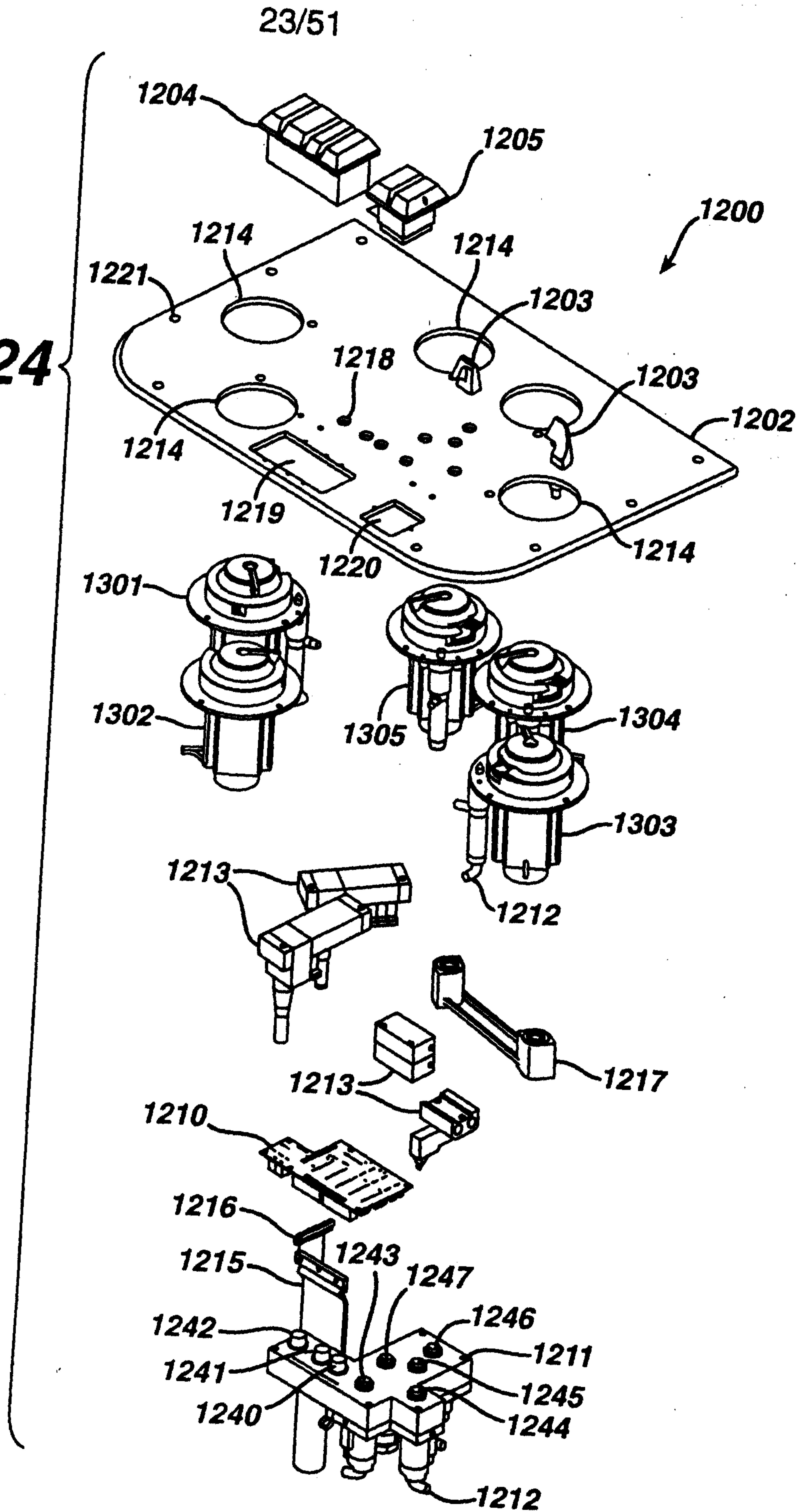
FIG. 22

22/51

**FIG. 23**



**FIG. 24**



24/51

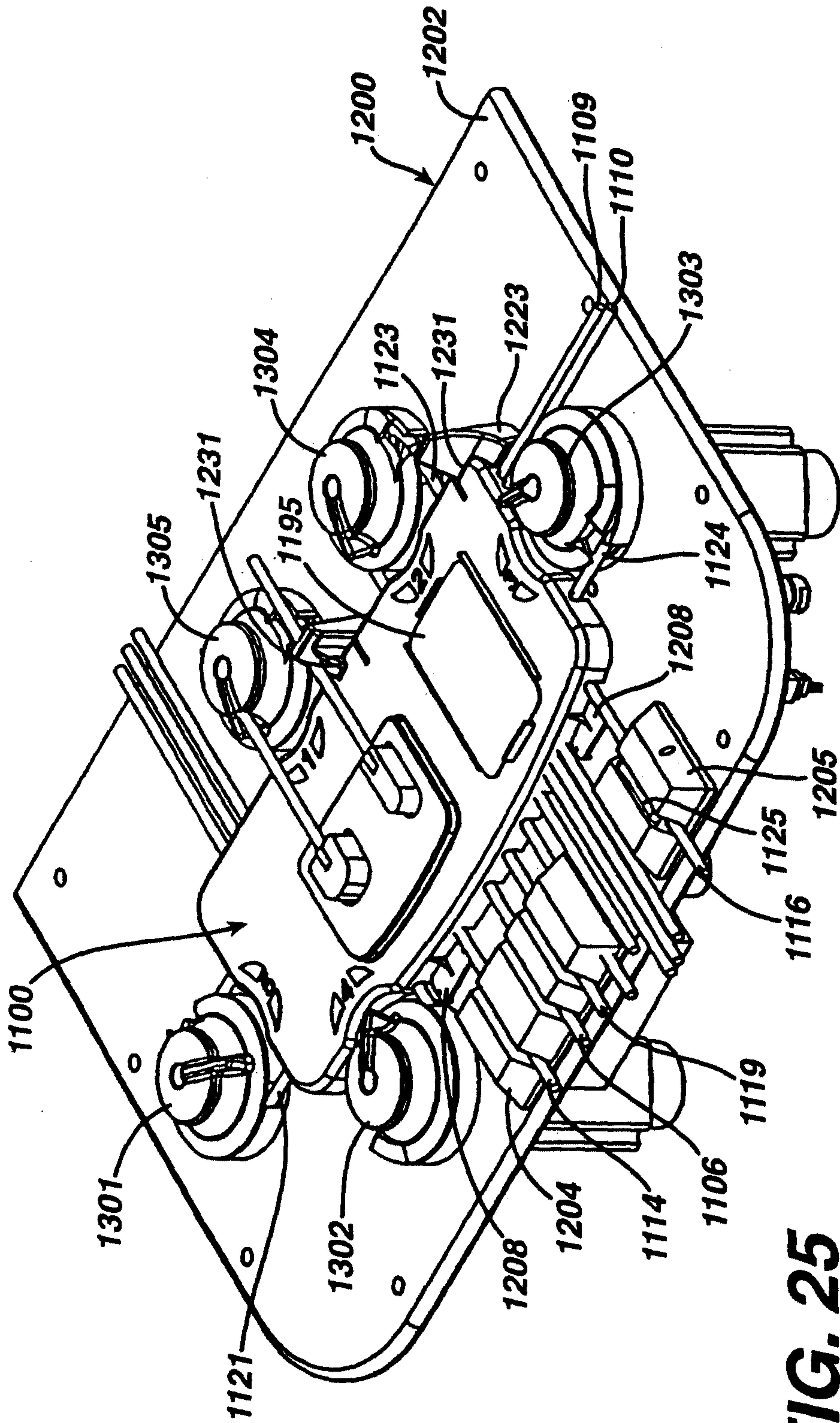
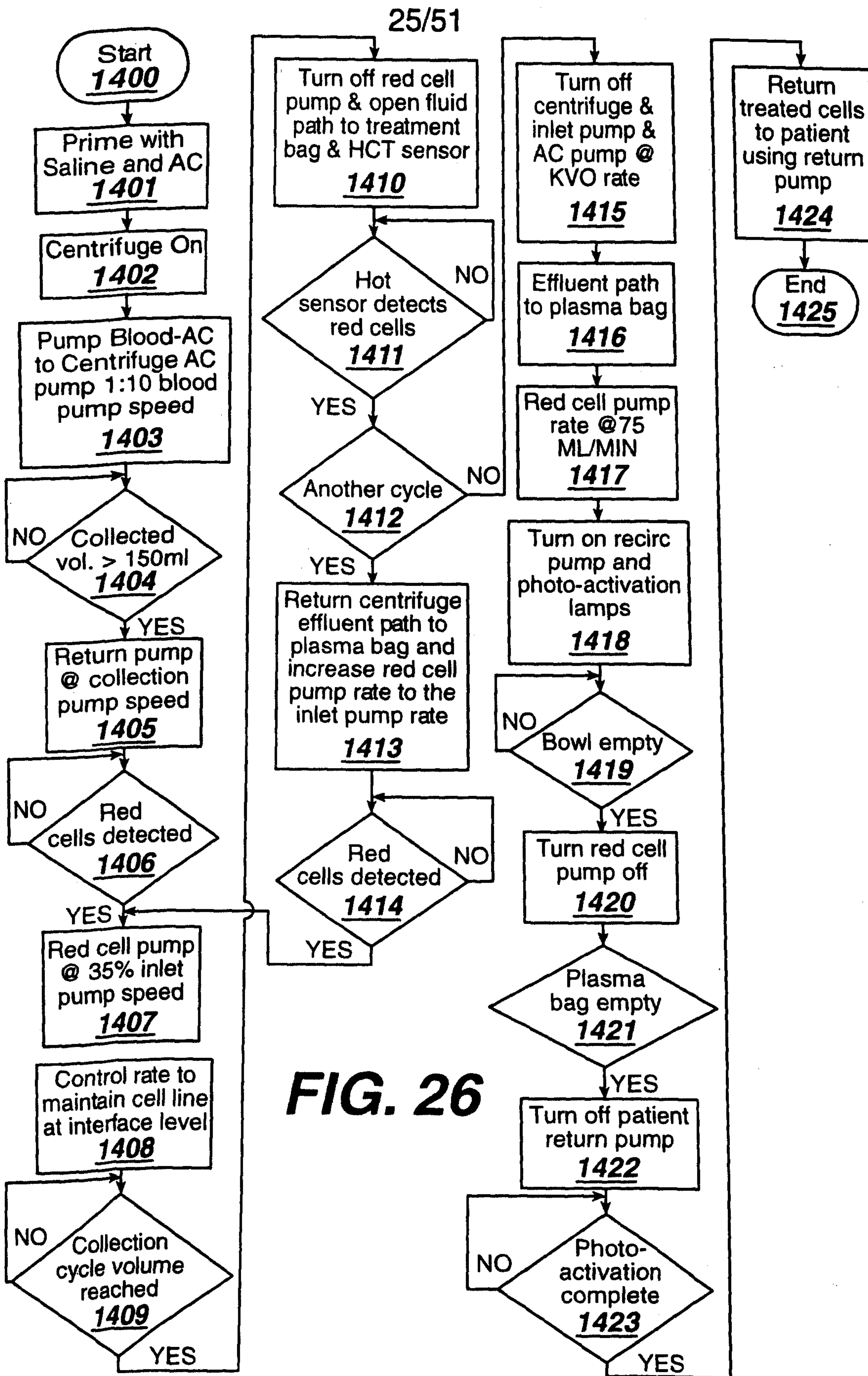


FIG. 25



**FIG. 26**



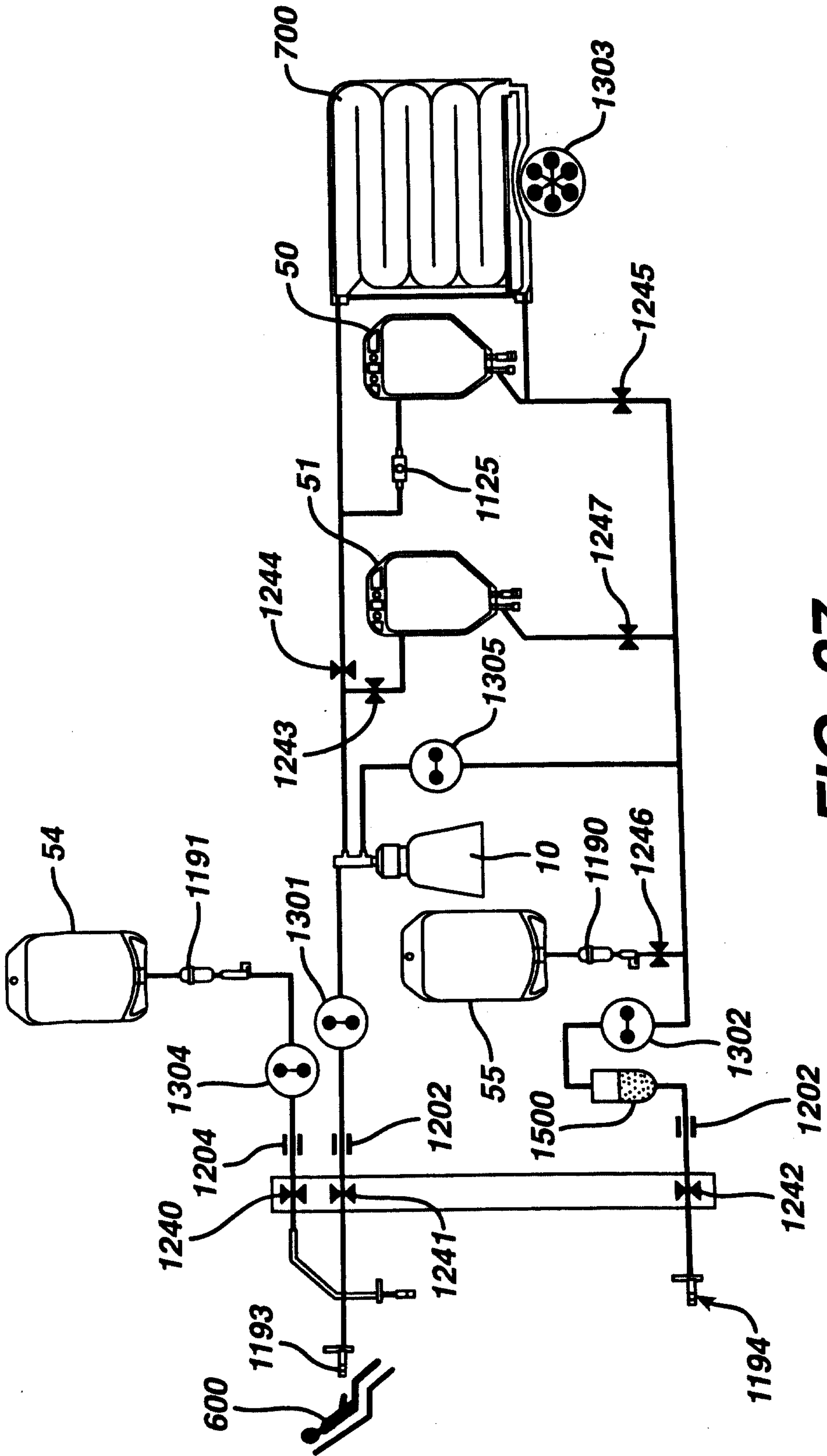
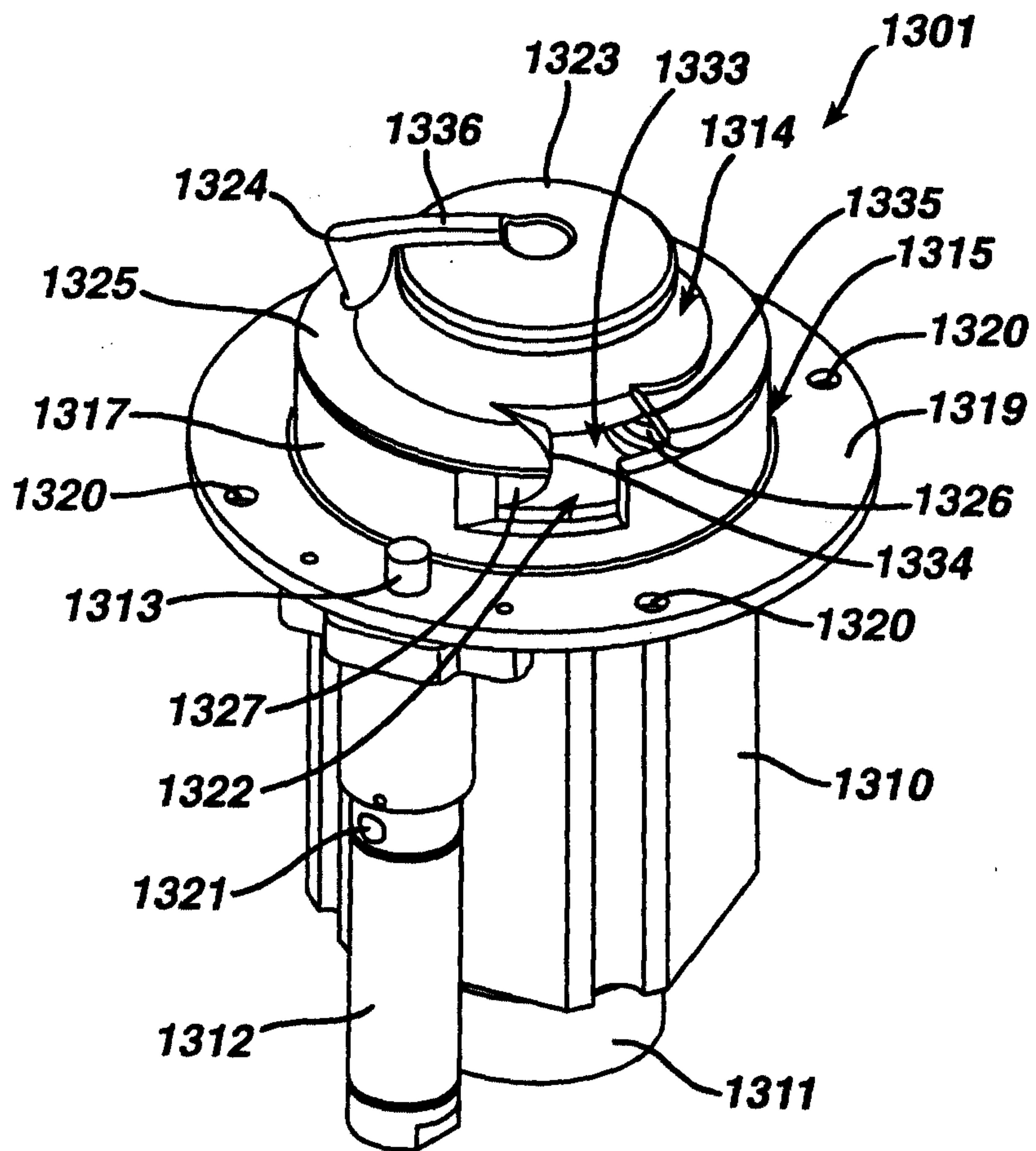


FIG. 27

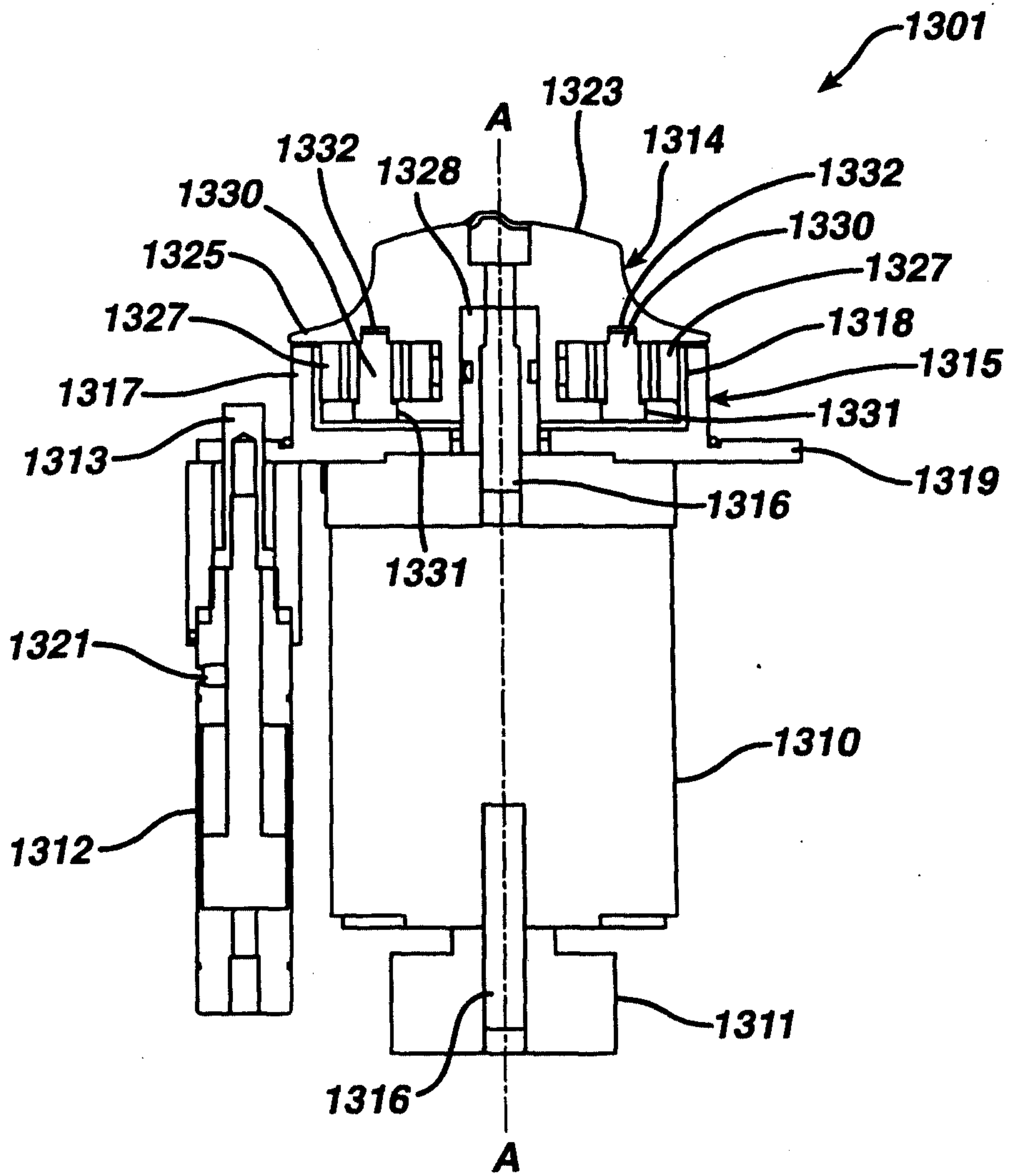
27/51

**FIG. 28**



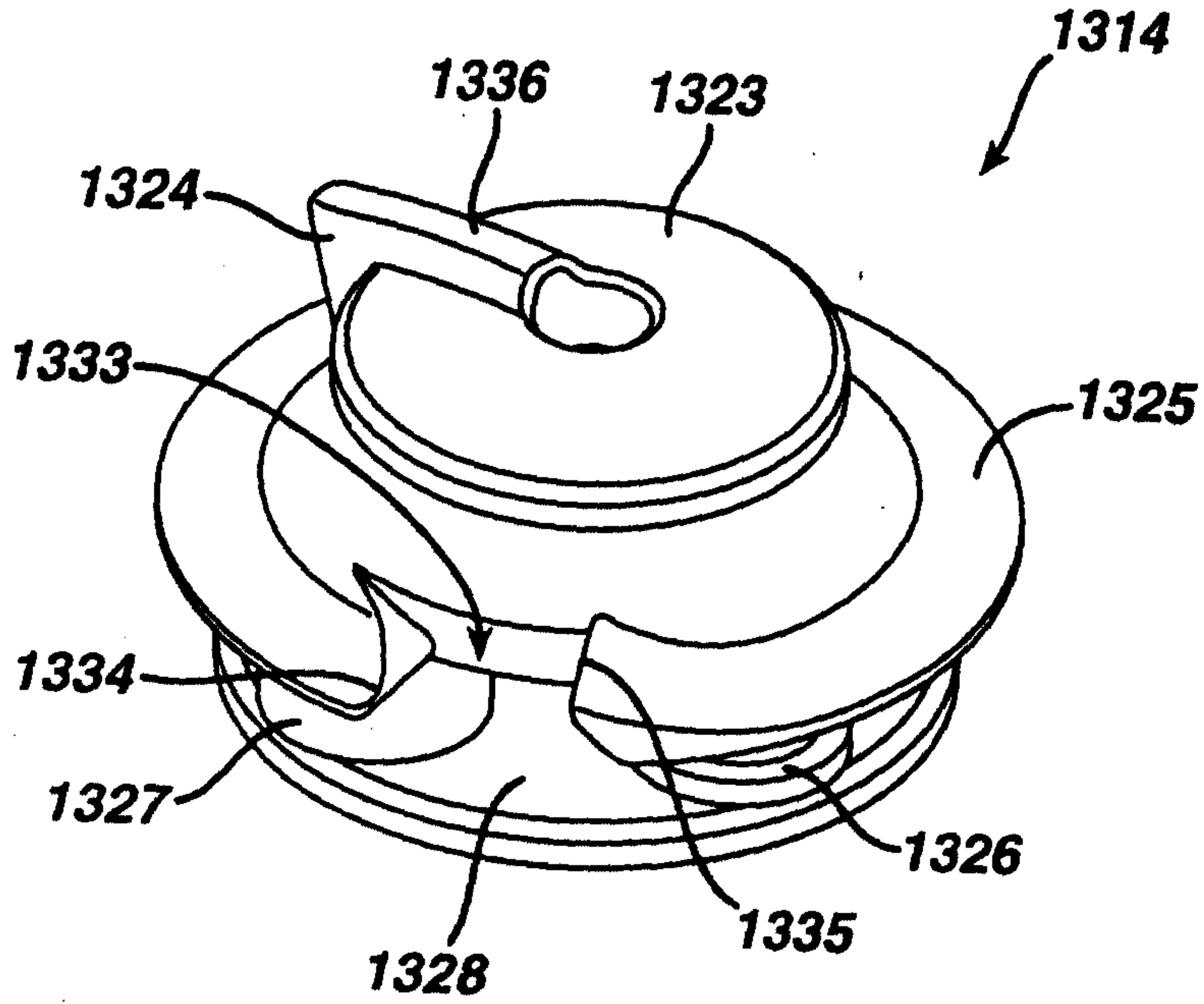
28/51

**FIG. 29**

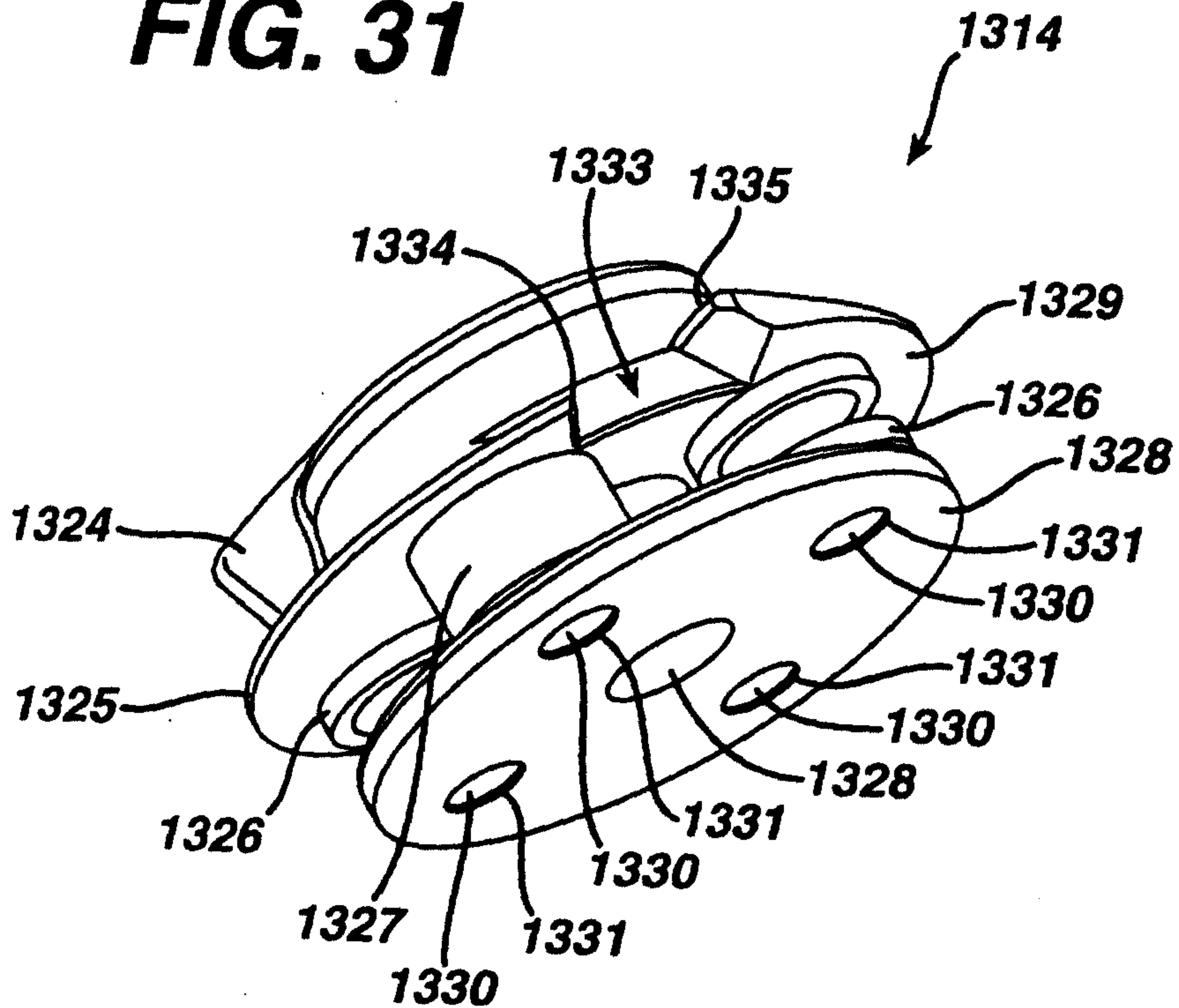


29/51

**FIG. 30**

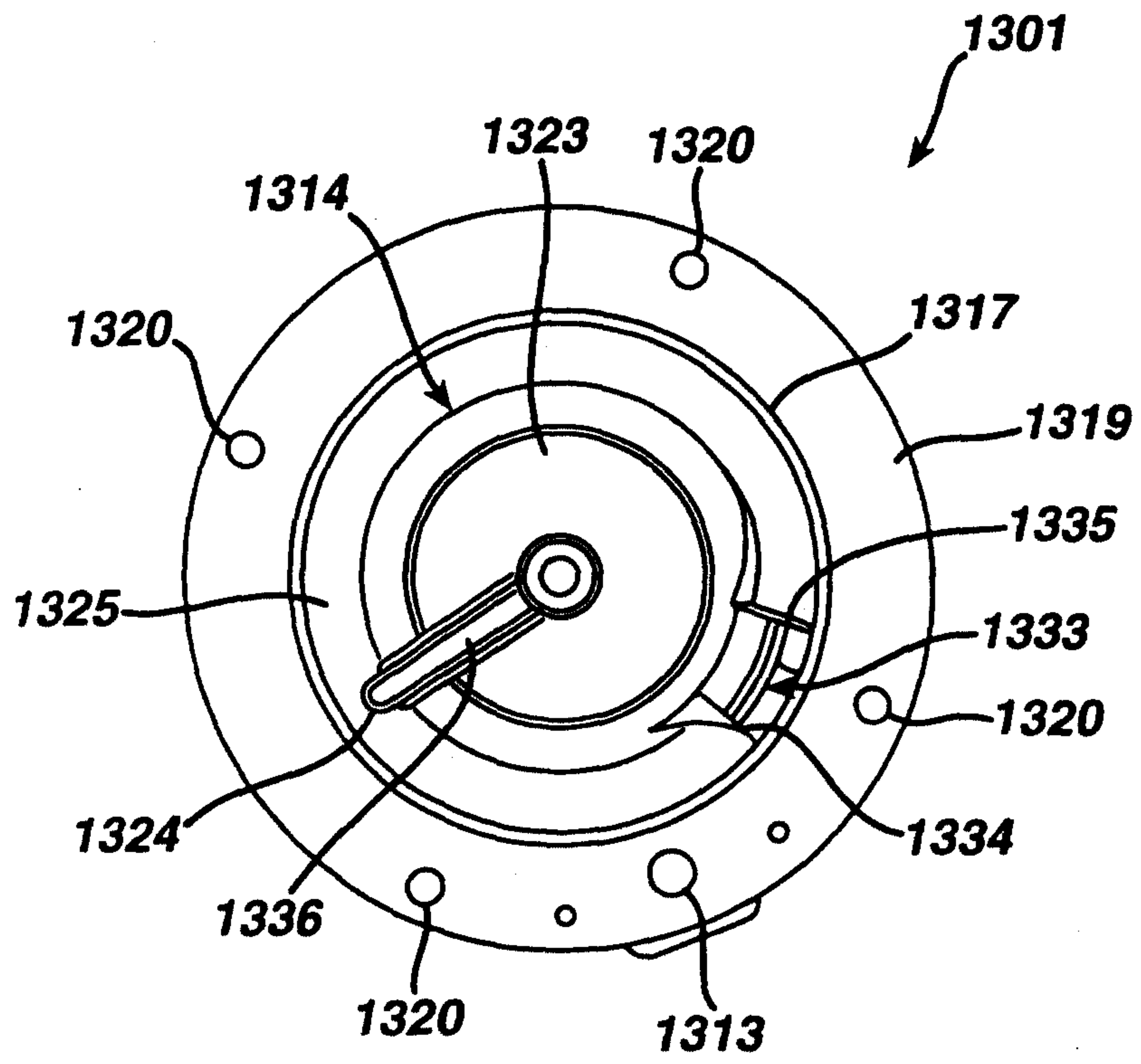


**FIG. 31**



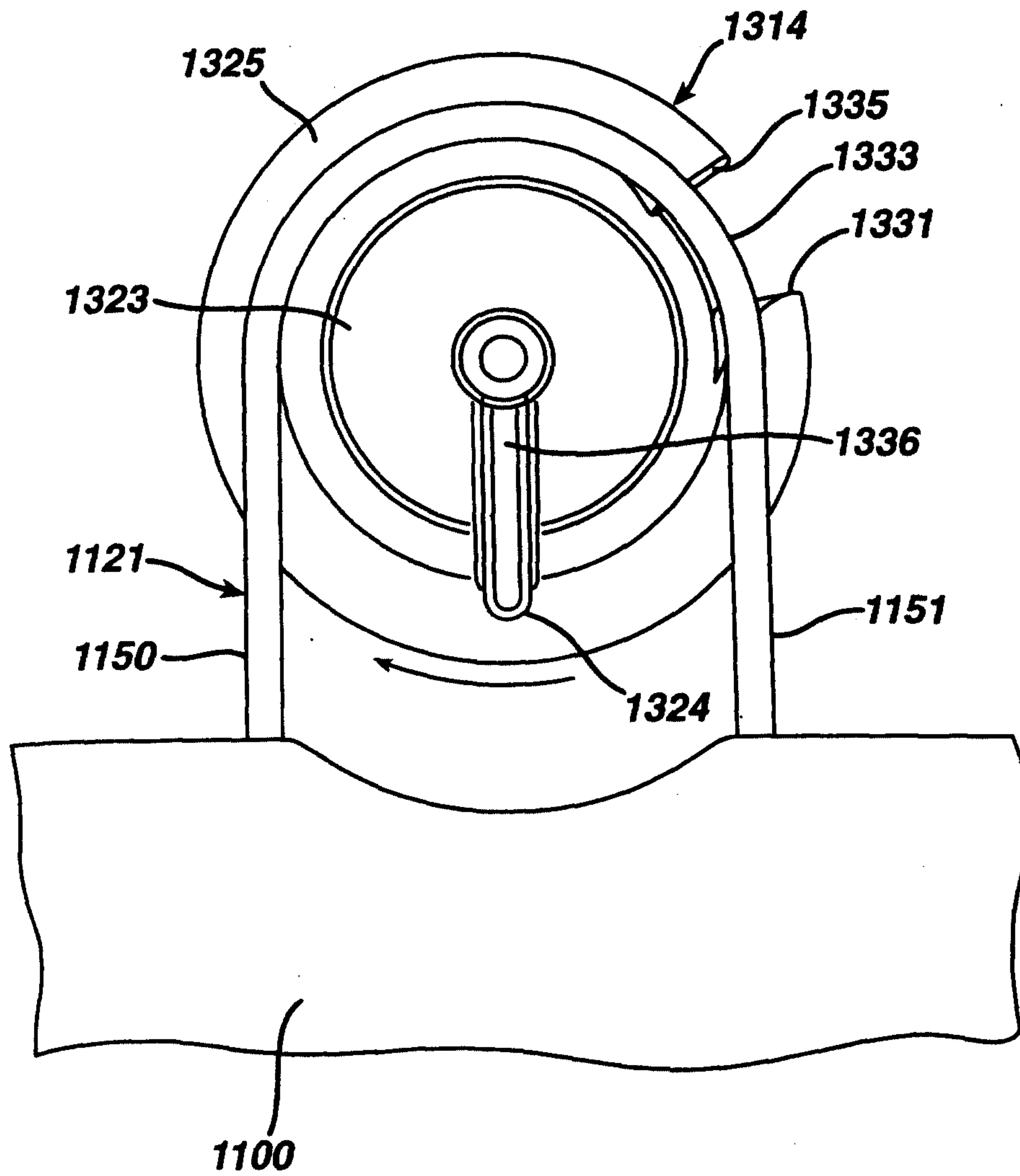
30/51

**FIG. 32**



31/51

**FIG. 33**



32/51

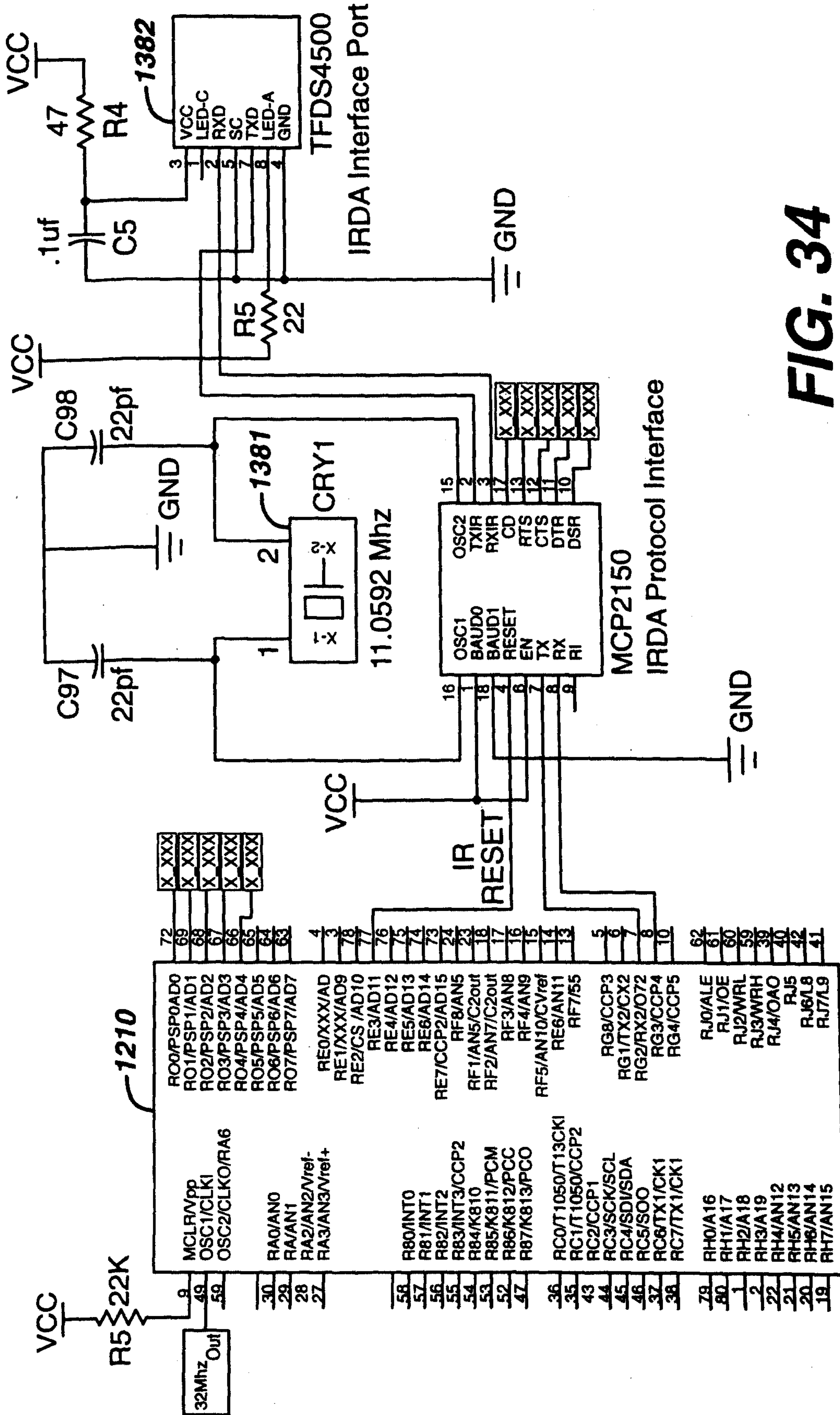


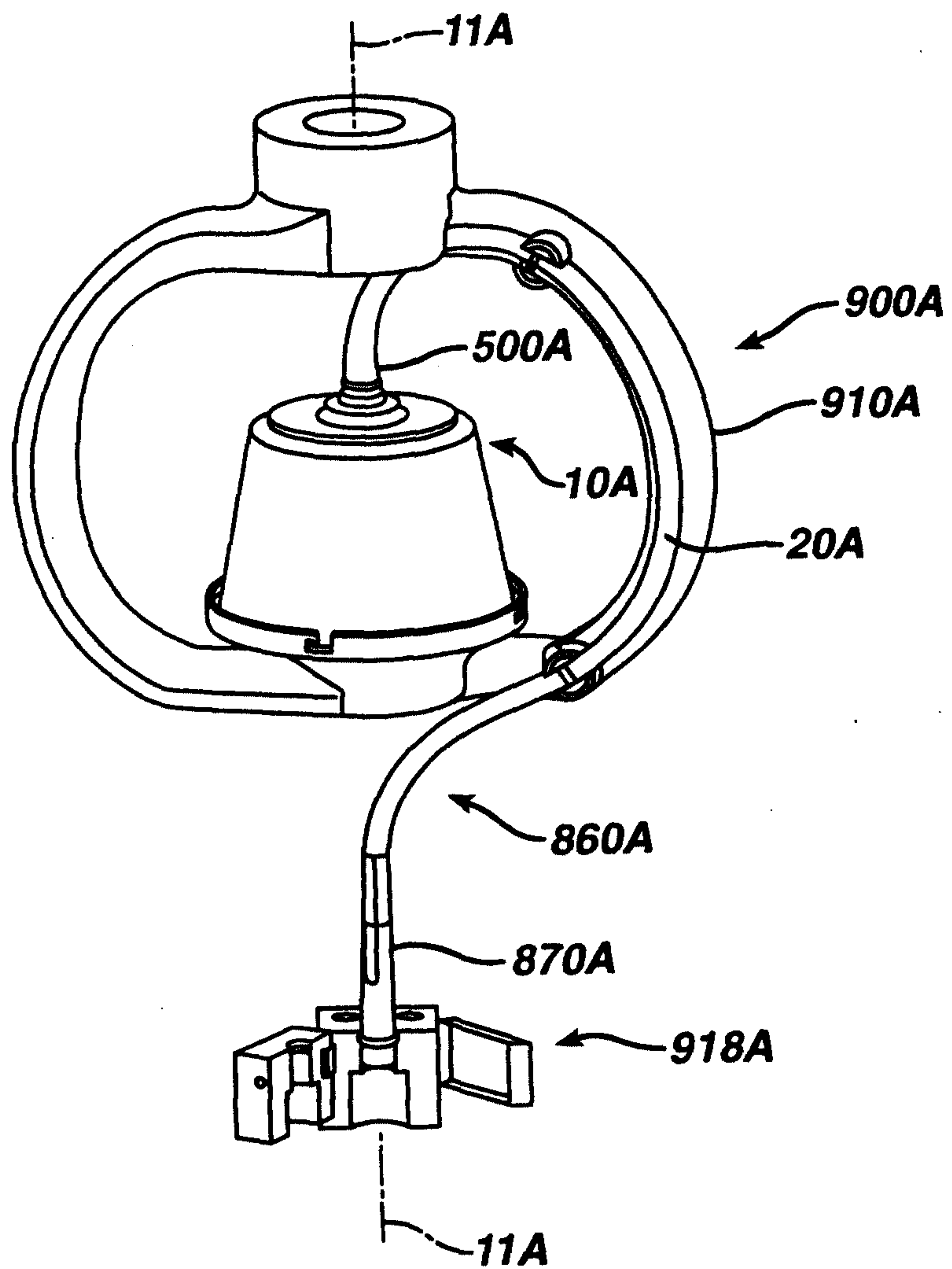
FIG. 34

PIC18F8720

System CPU

33/51

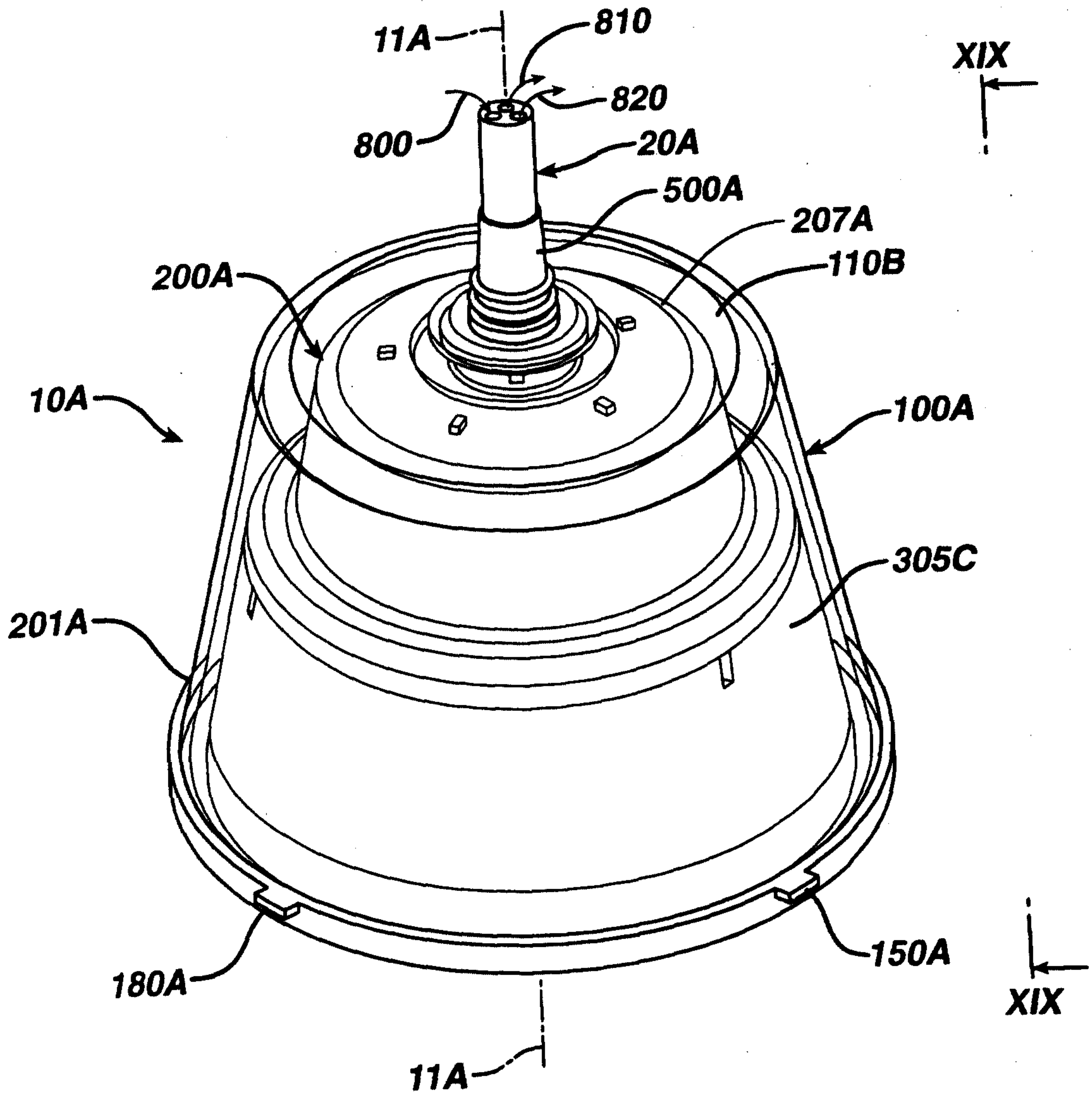
**FIG. 35**





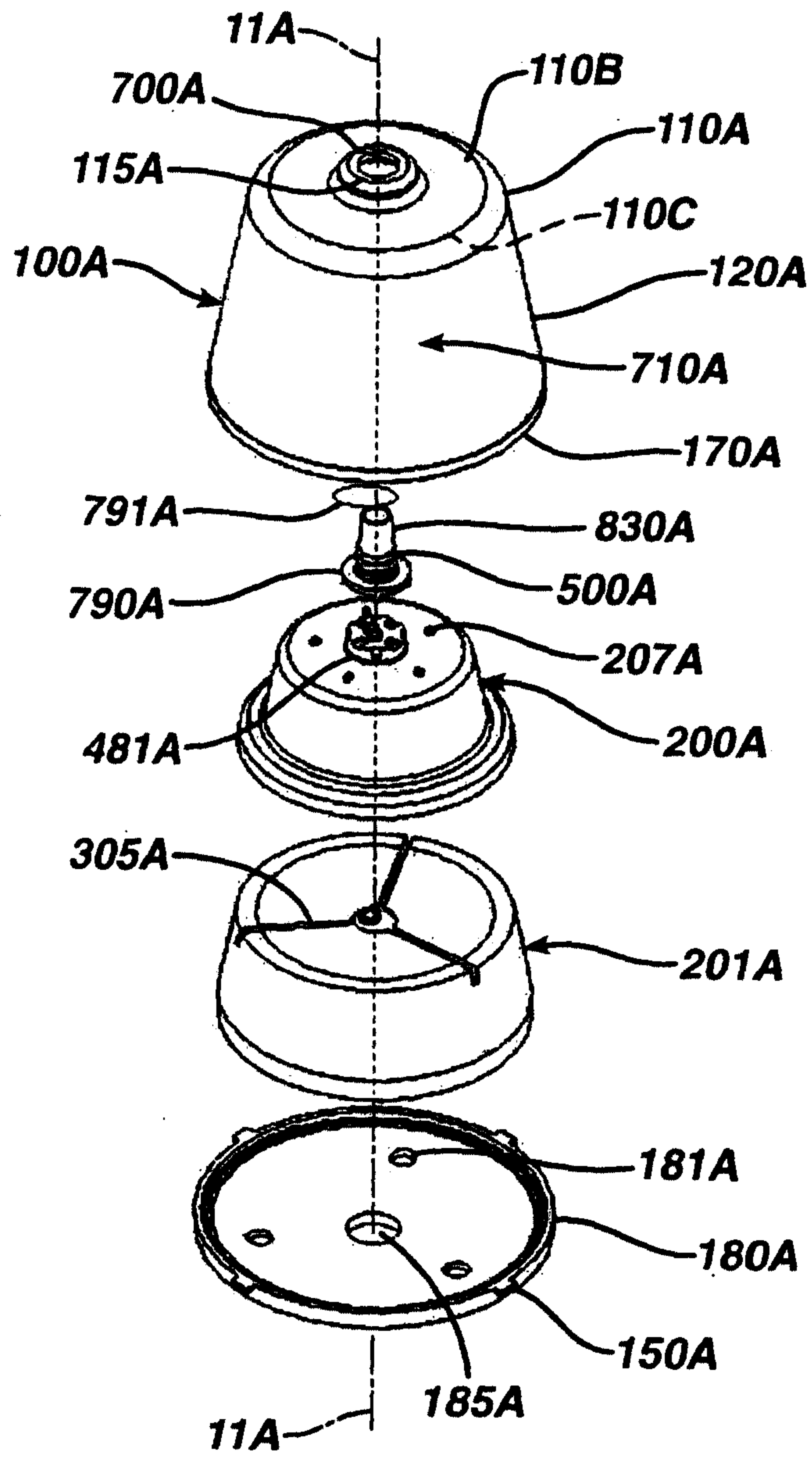
34/51

**FIG. 36**



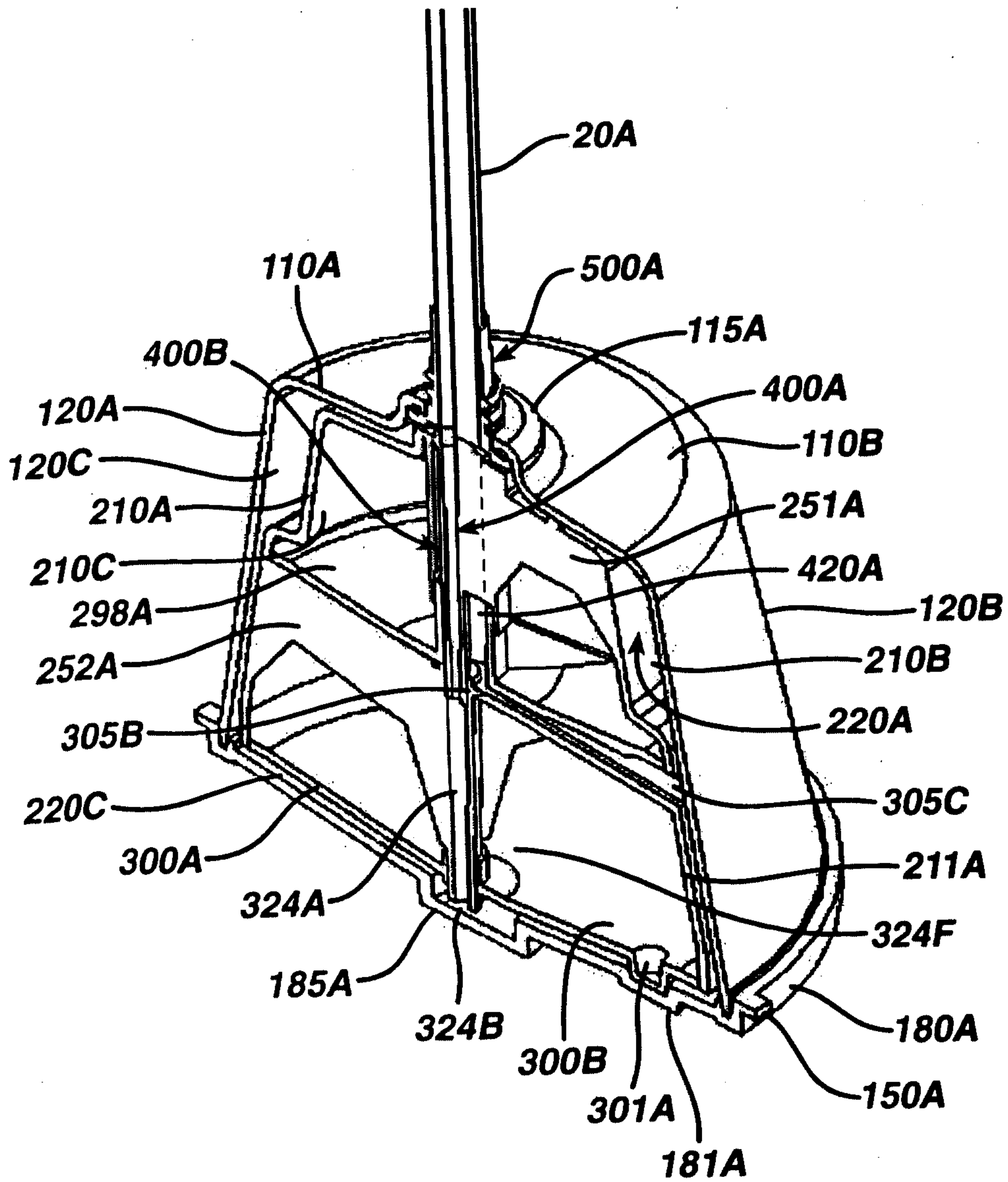
35/51

**FIG. 37**



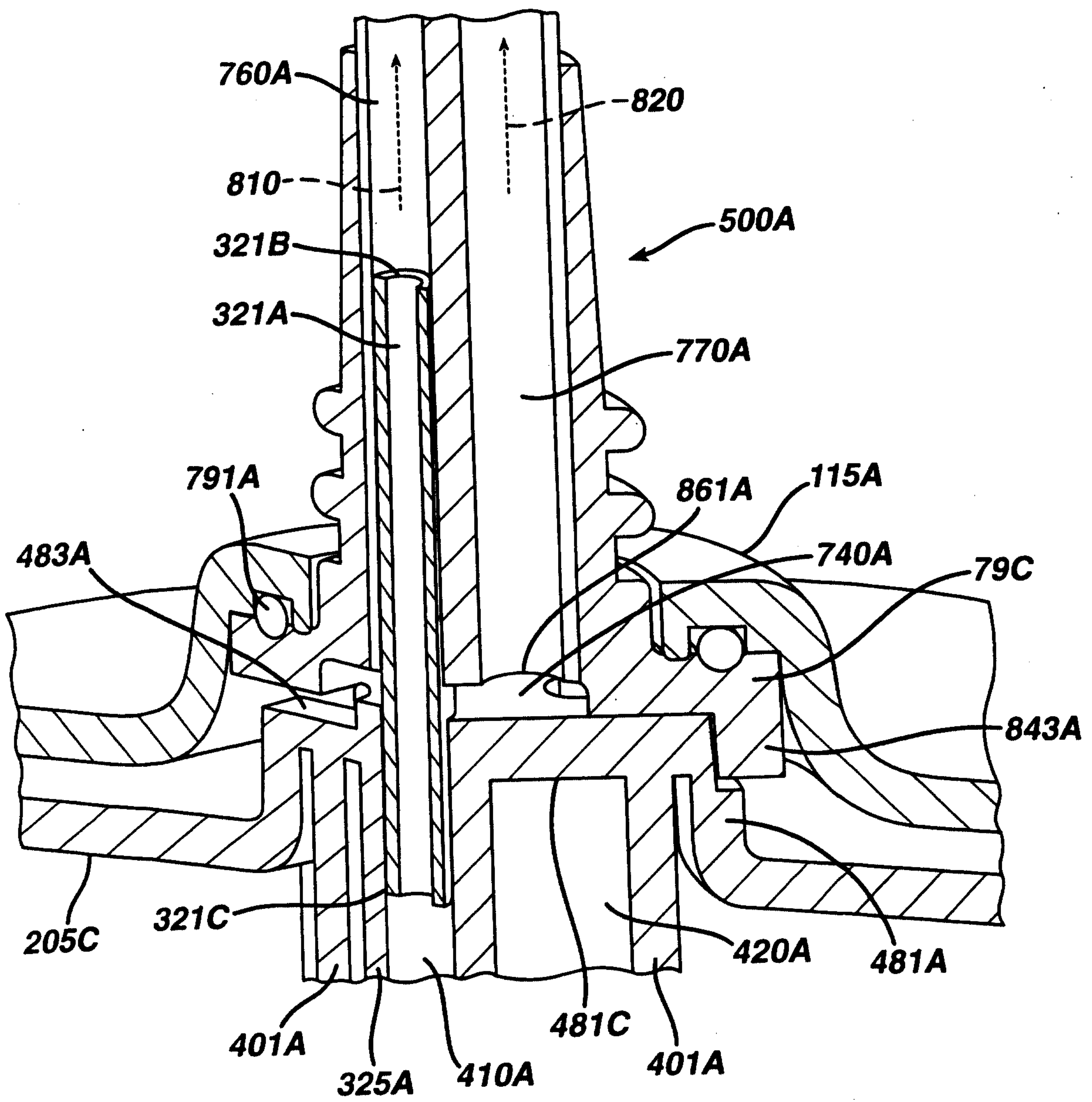
36/51

**FIG. 38**



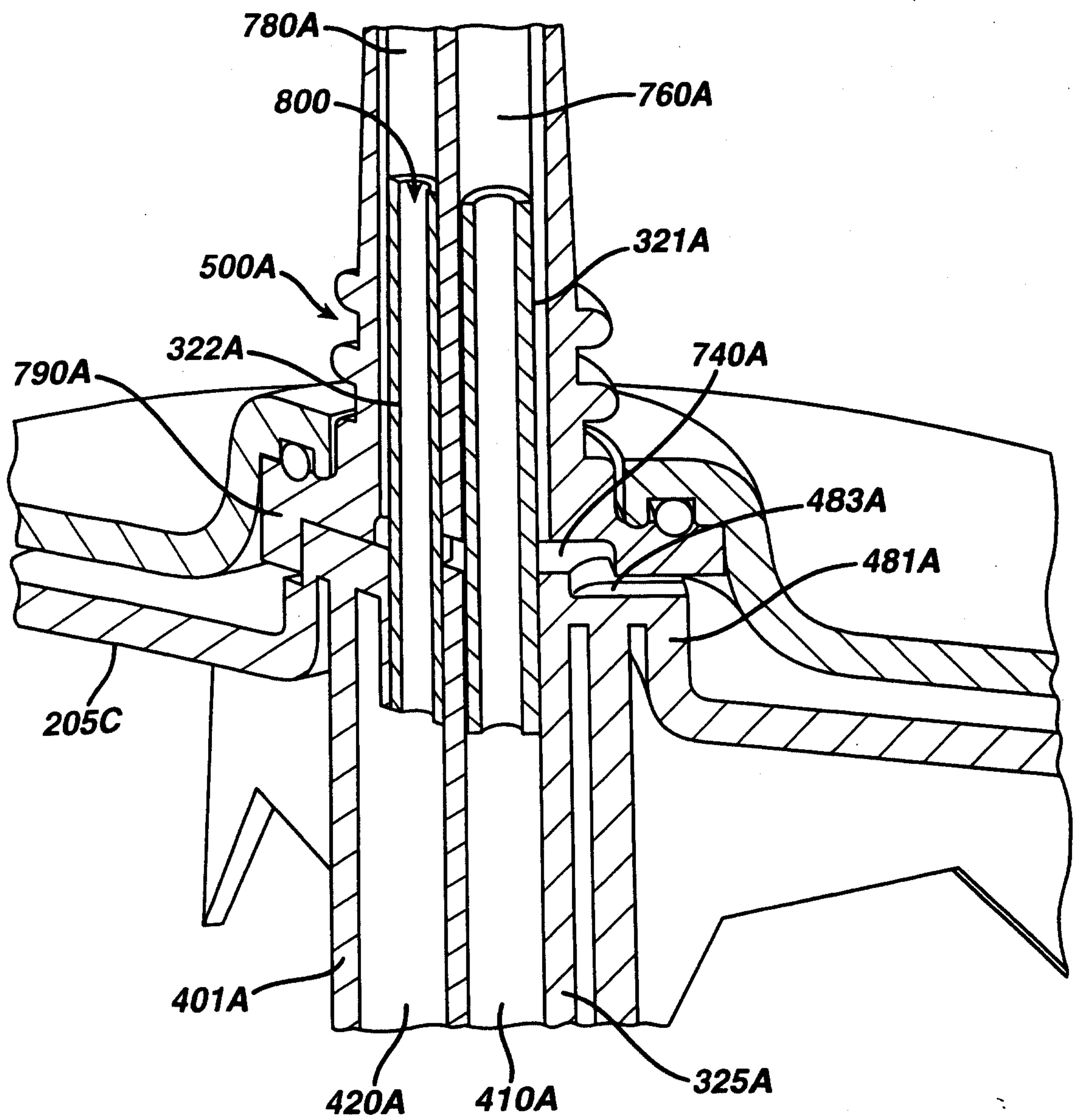
37/51

**FIG. 39A**

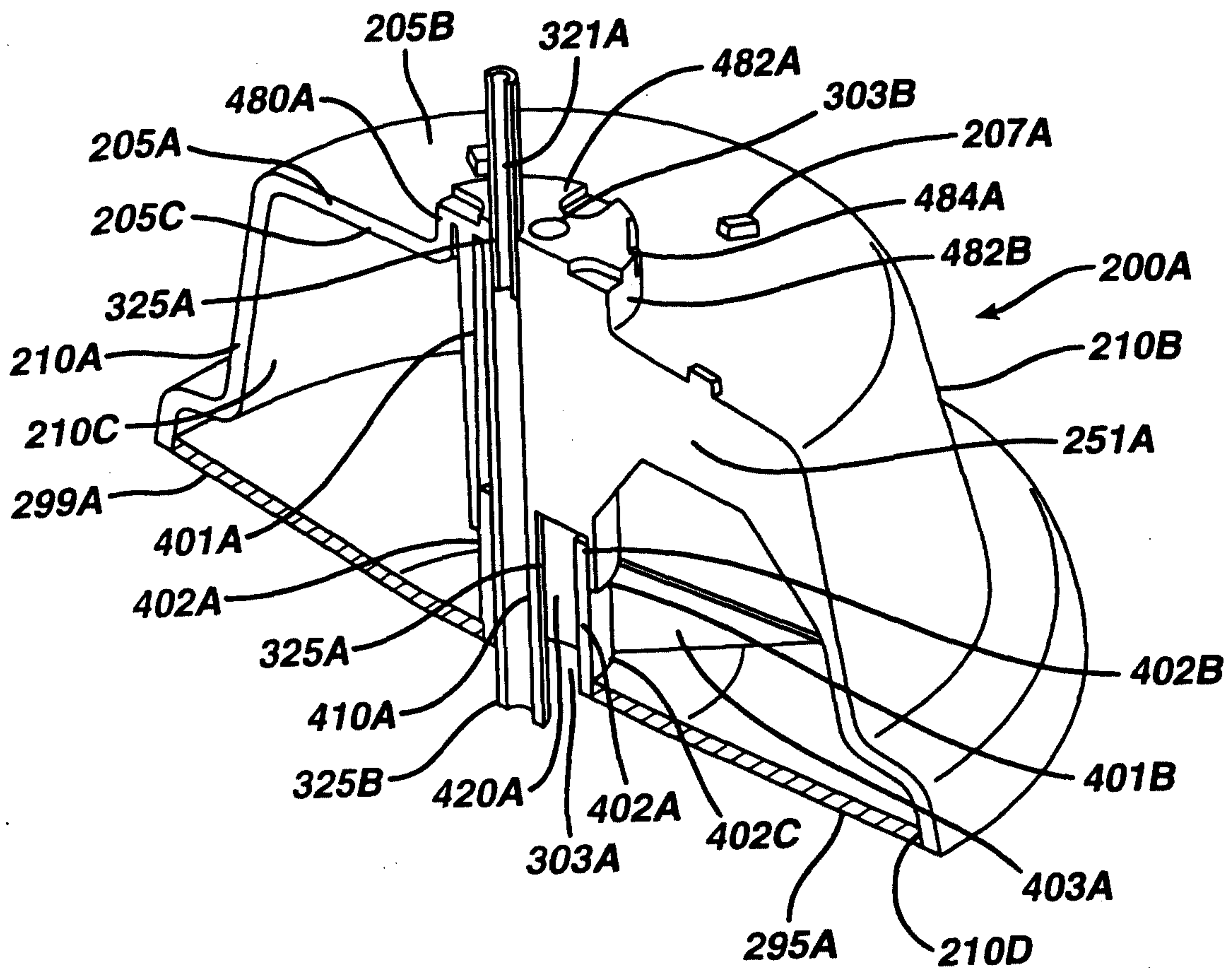


38/51

**FIG. 39B**

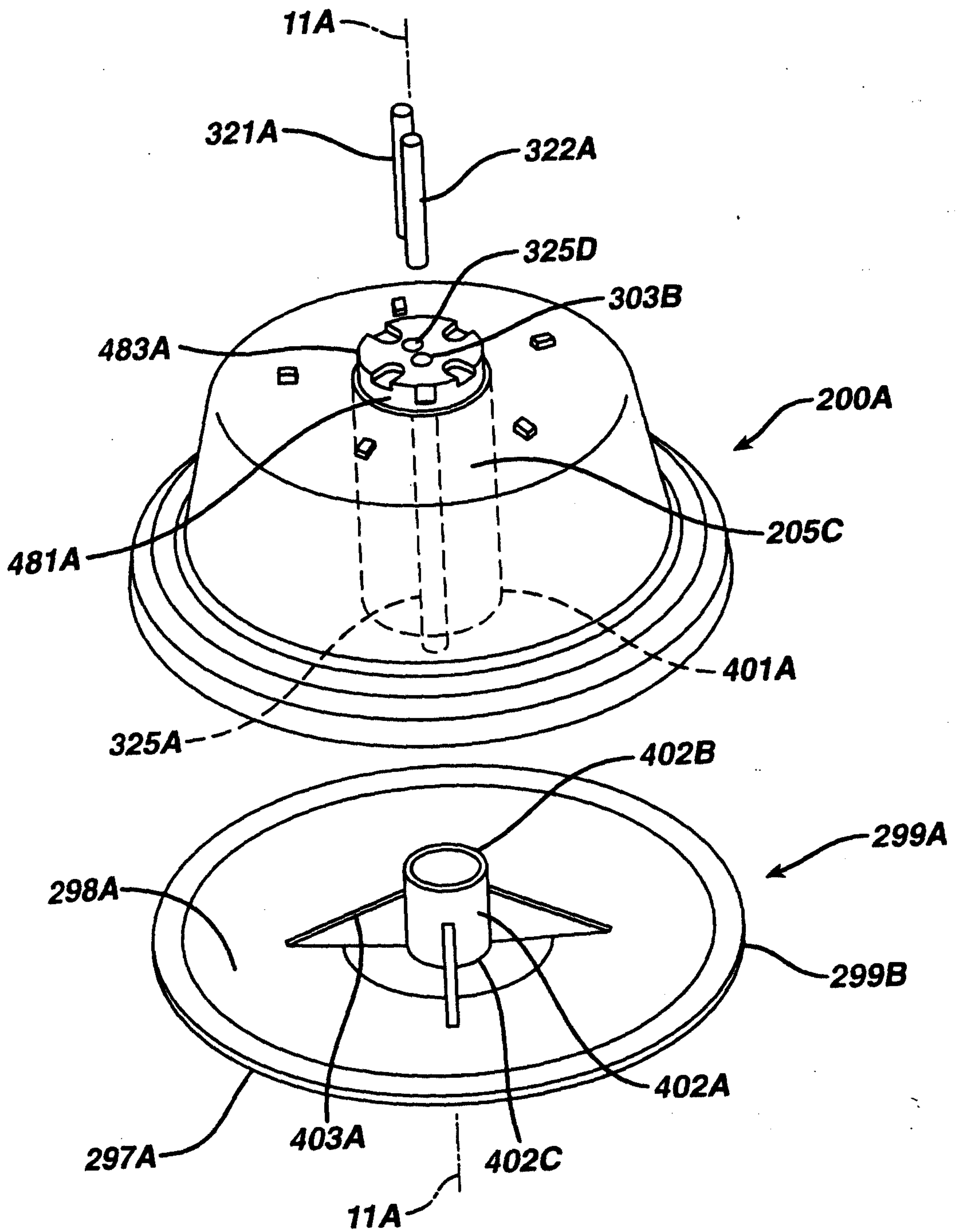


**FIG. 40**



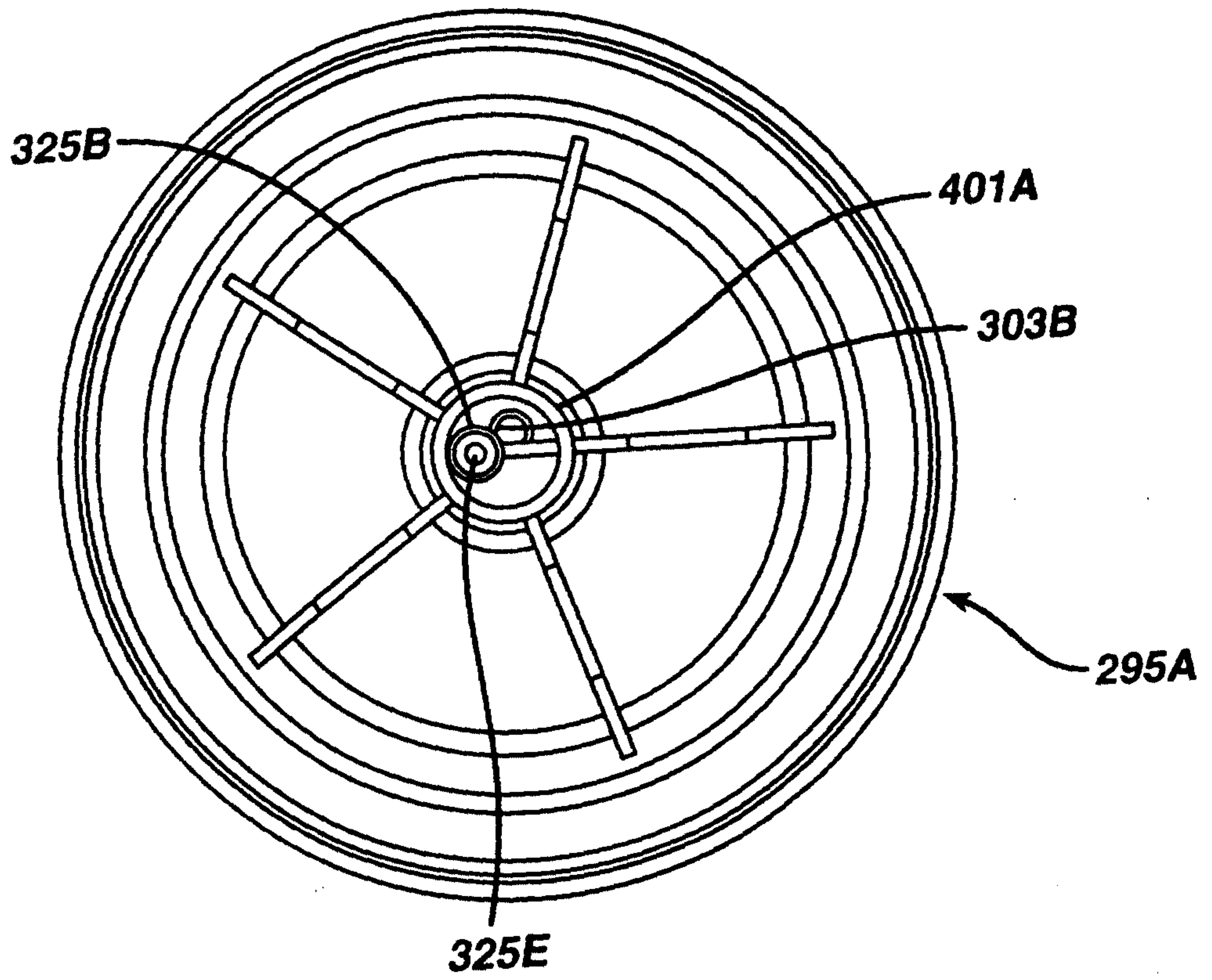
40/51

**FIG. 41**



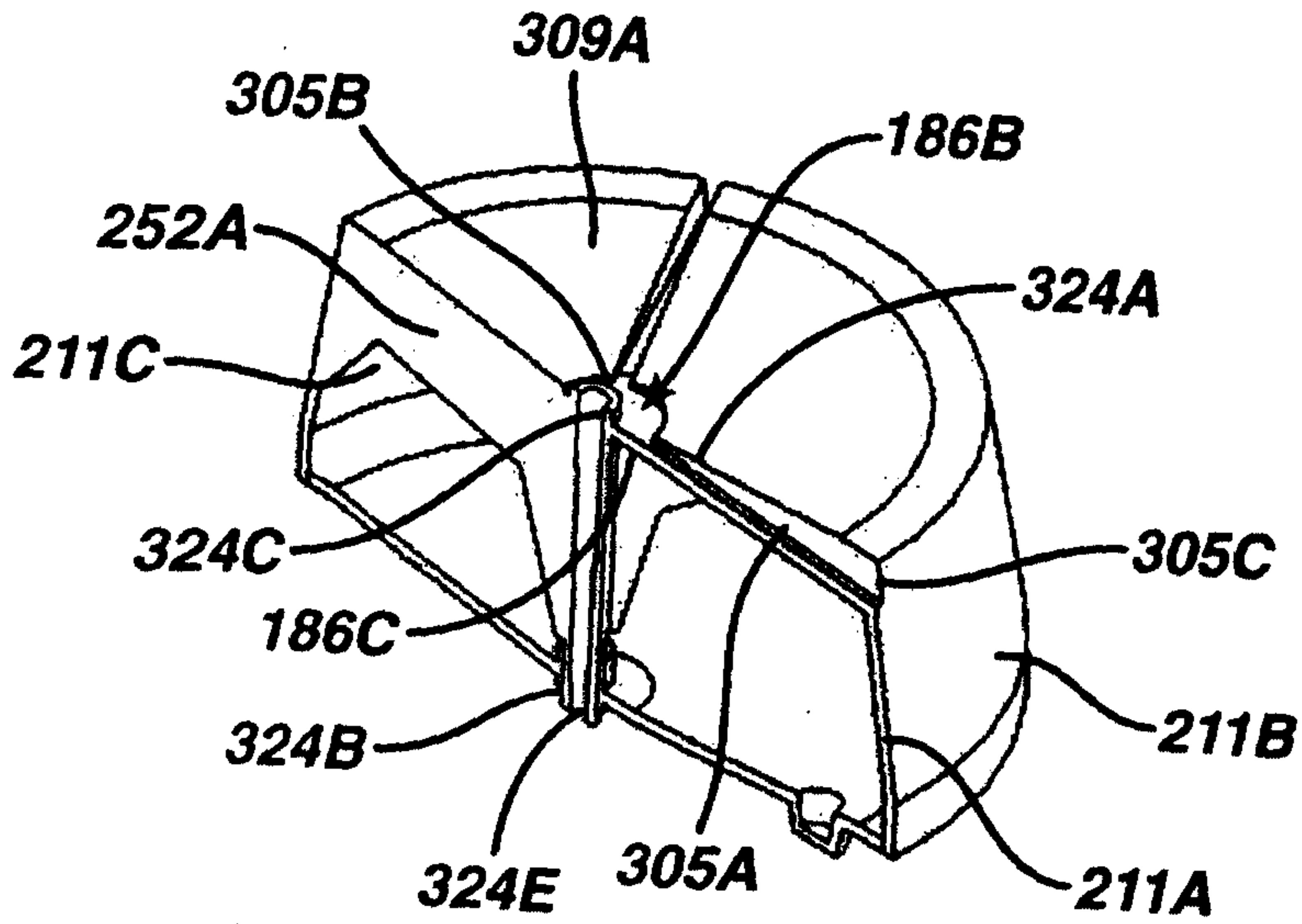
41/51

**FIG. 42**



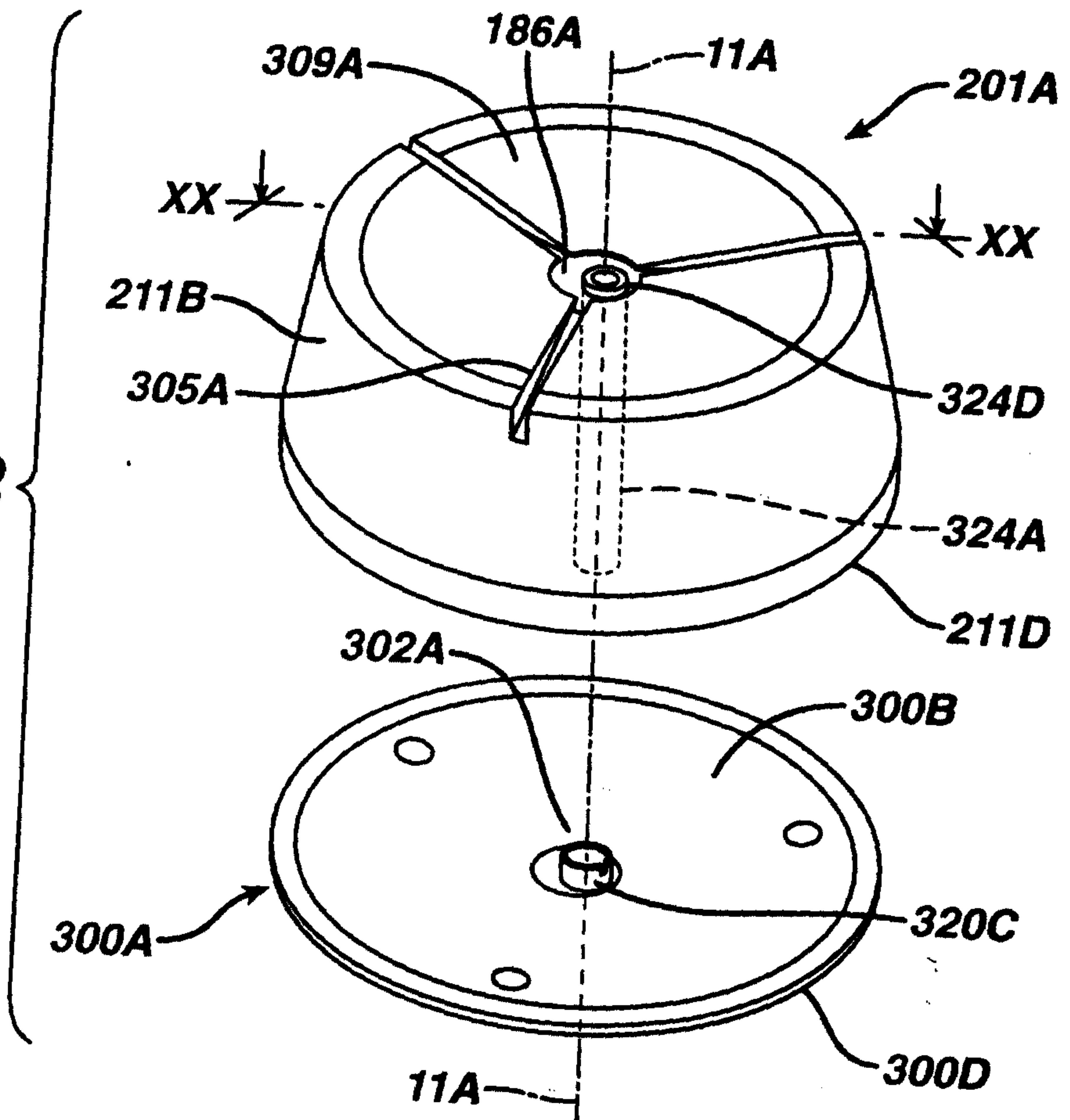


42/51



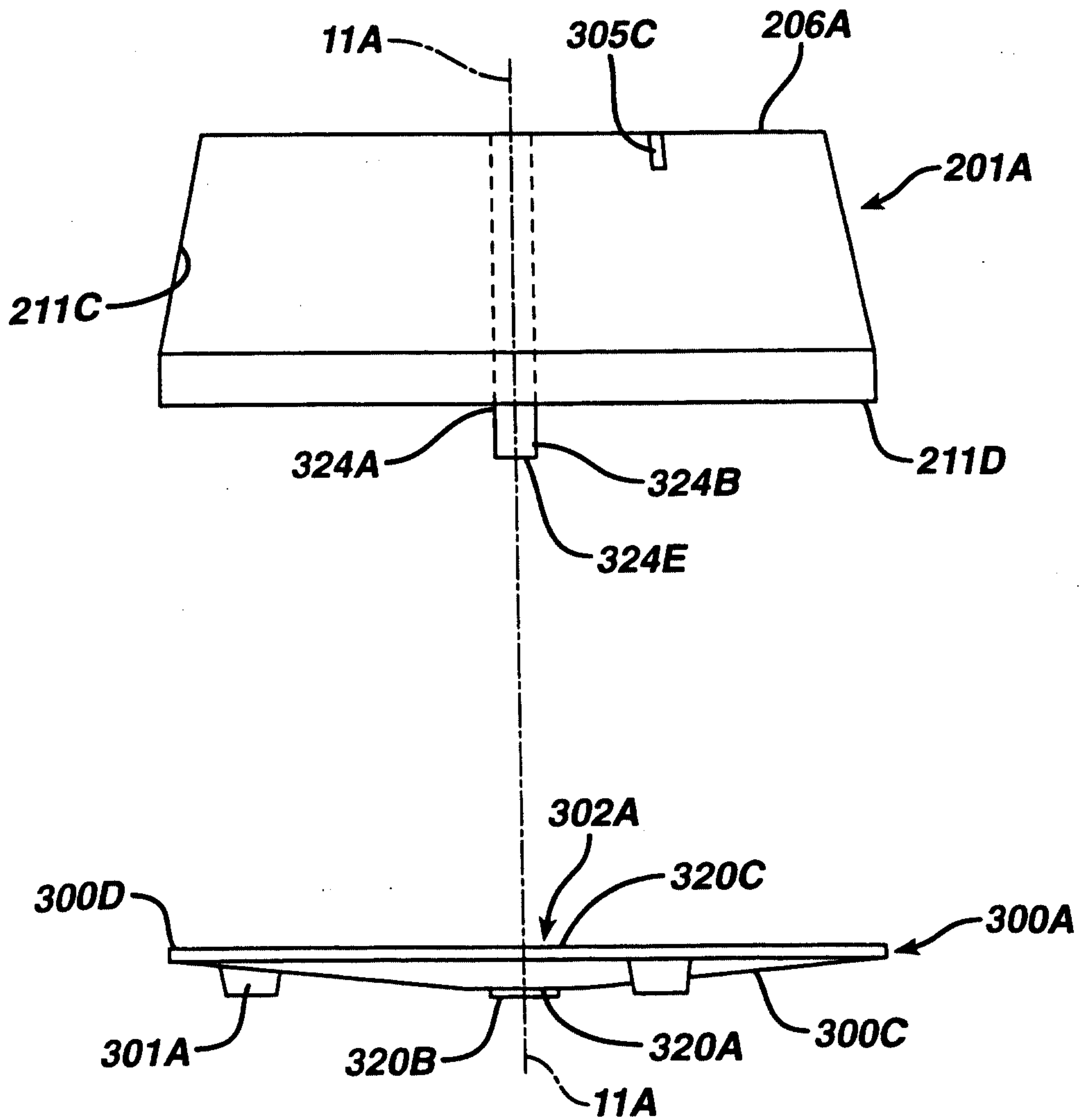
**FIG. 43A**

**FIG. 43B**

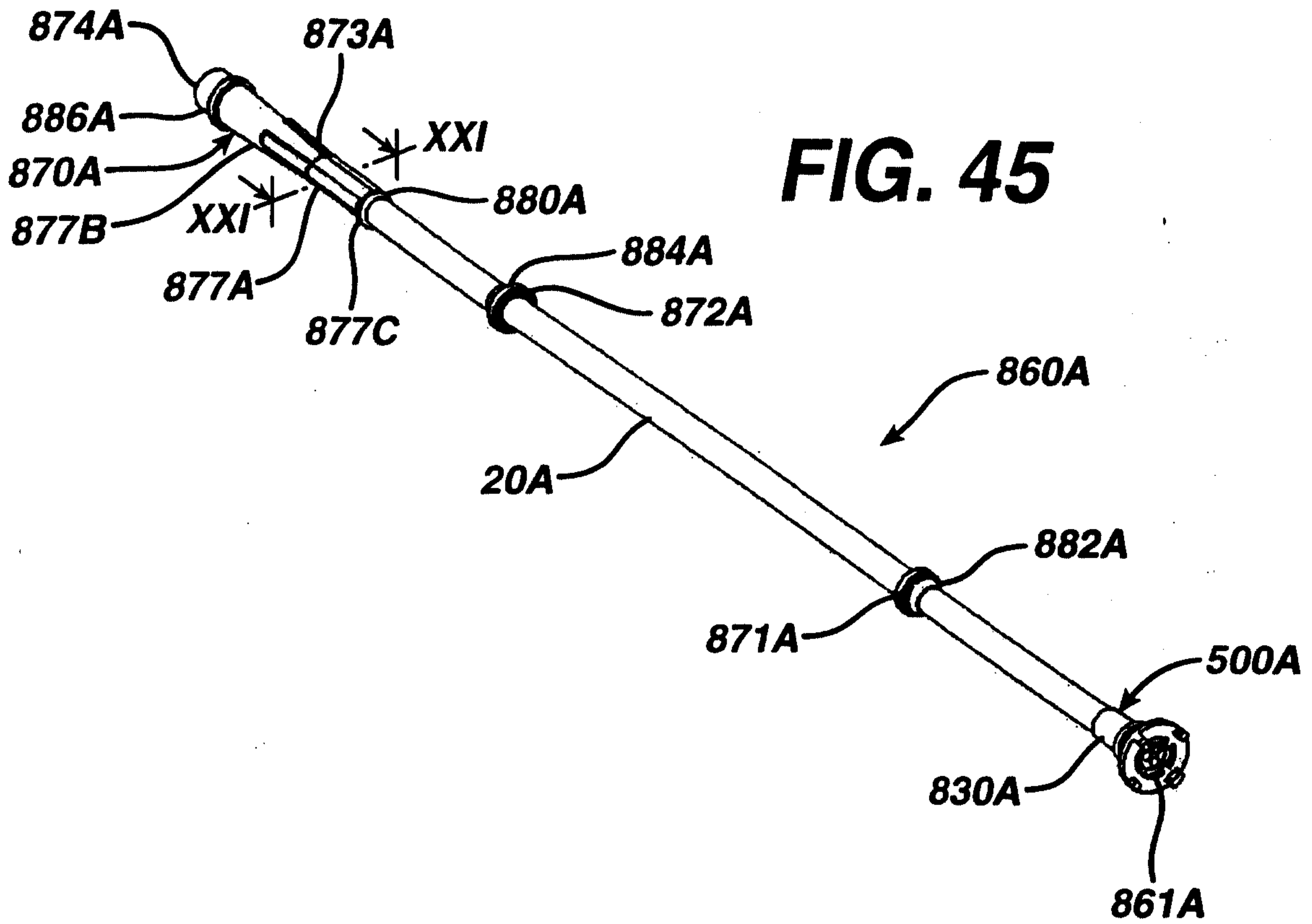


43/51

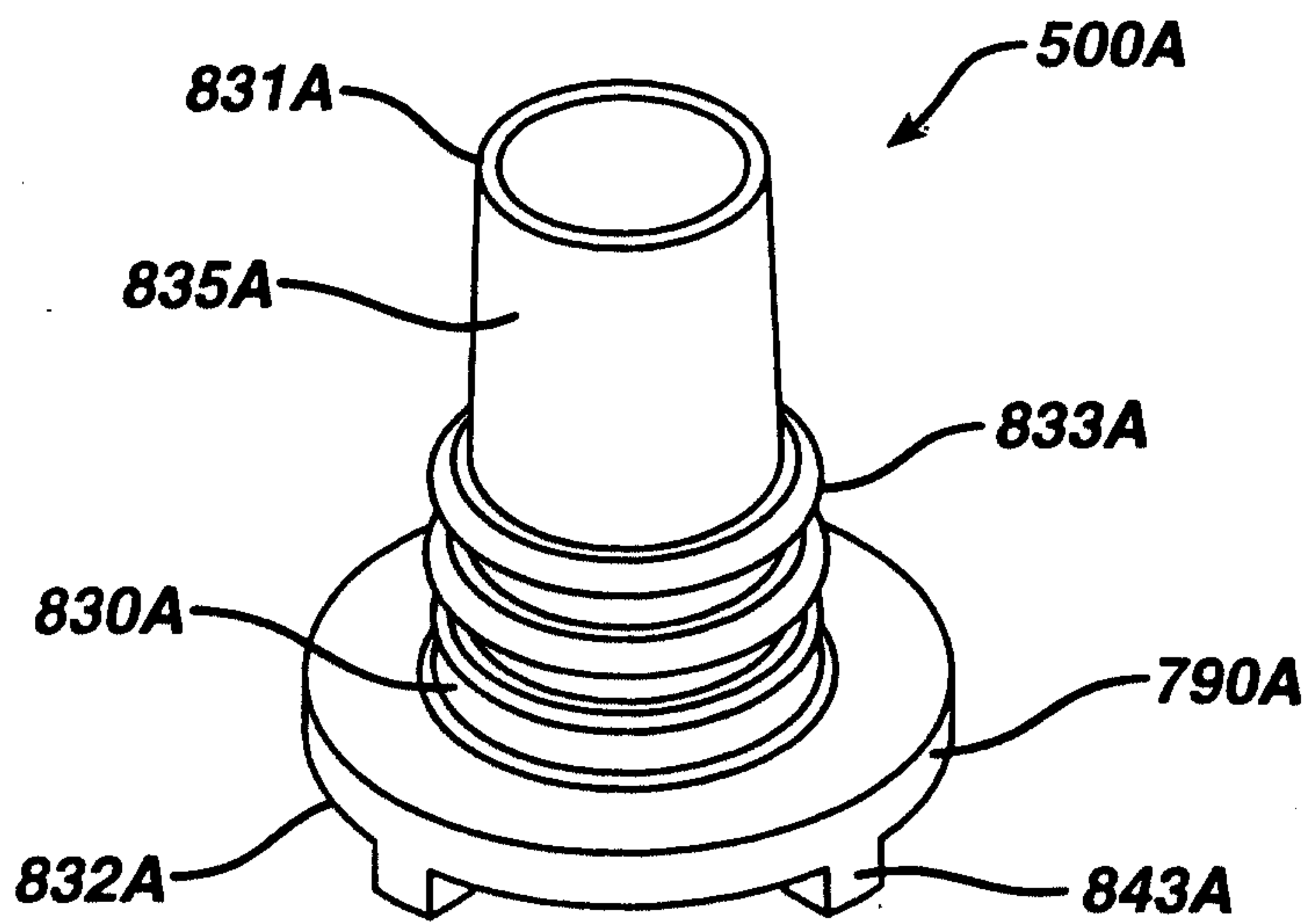
**FIG. 44**



44/51

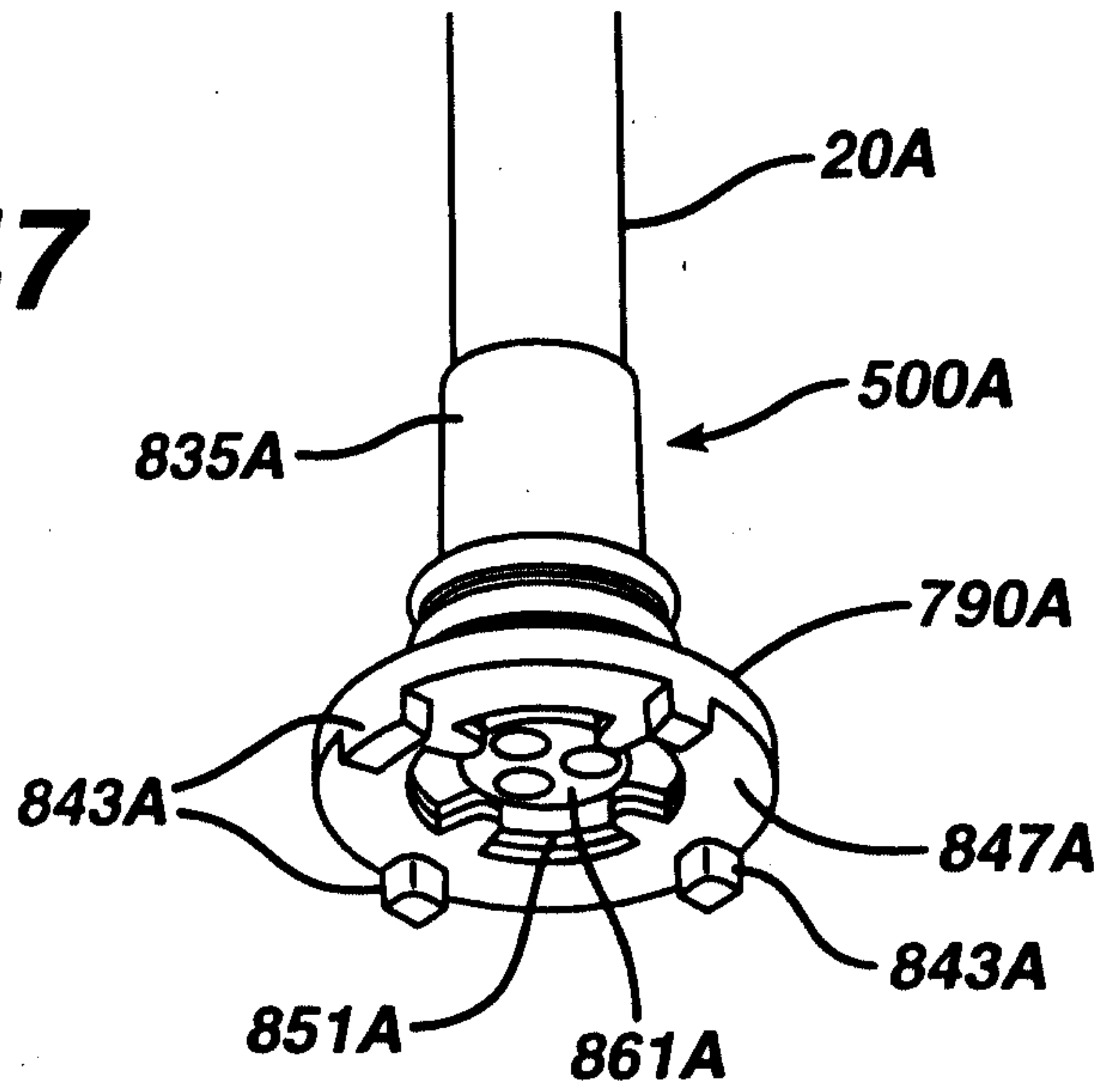


**FIG. 46**

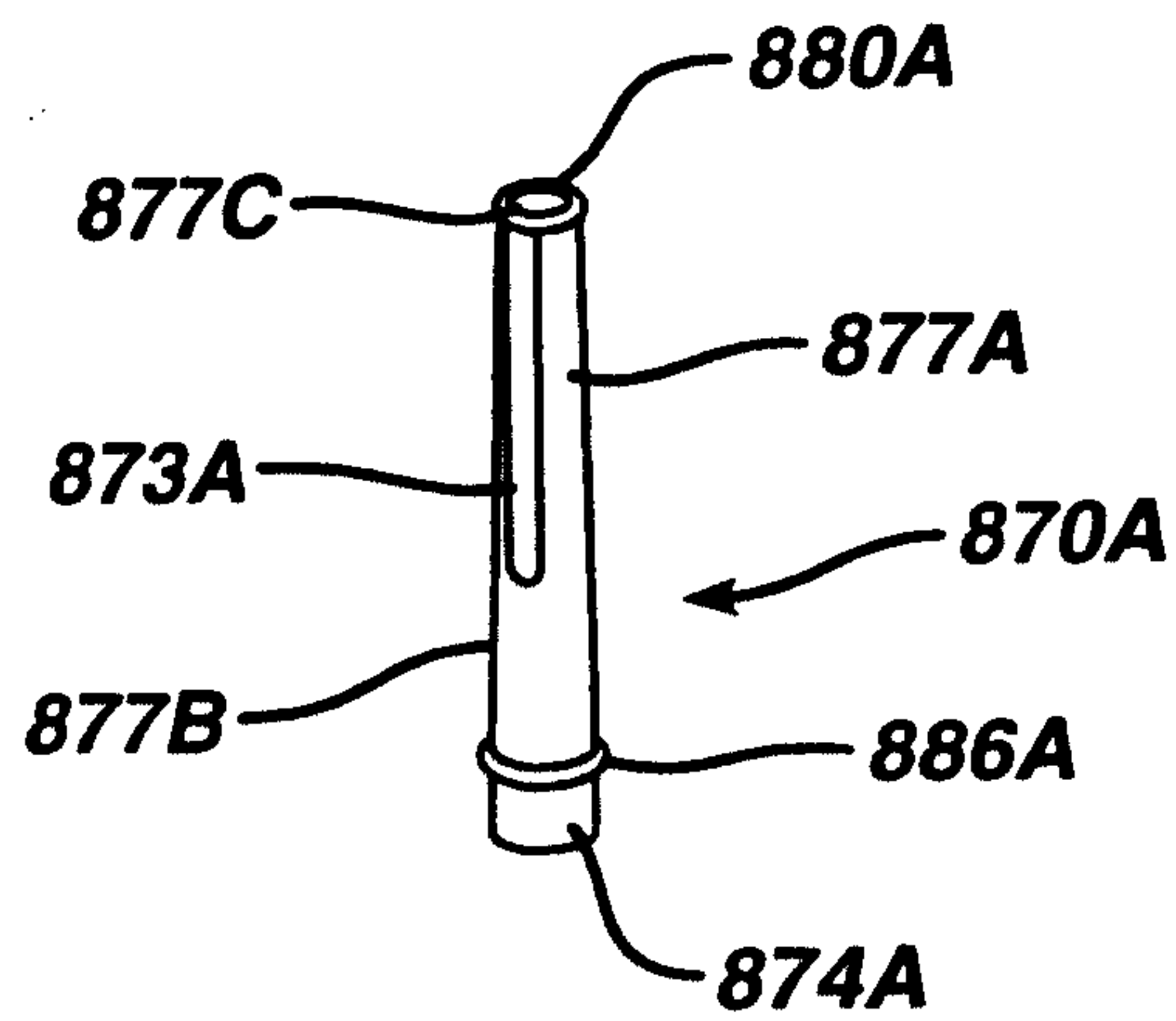


45/51

**FIG. 47**

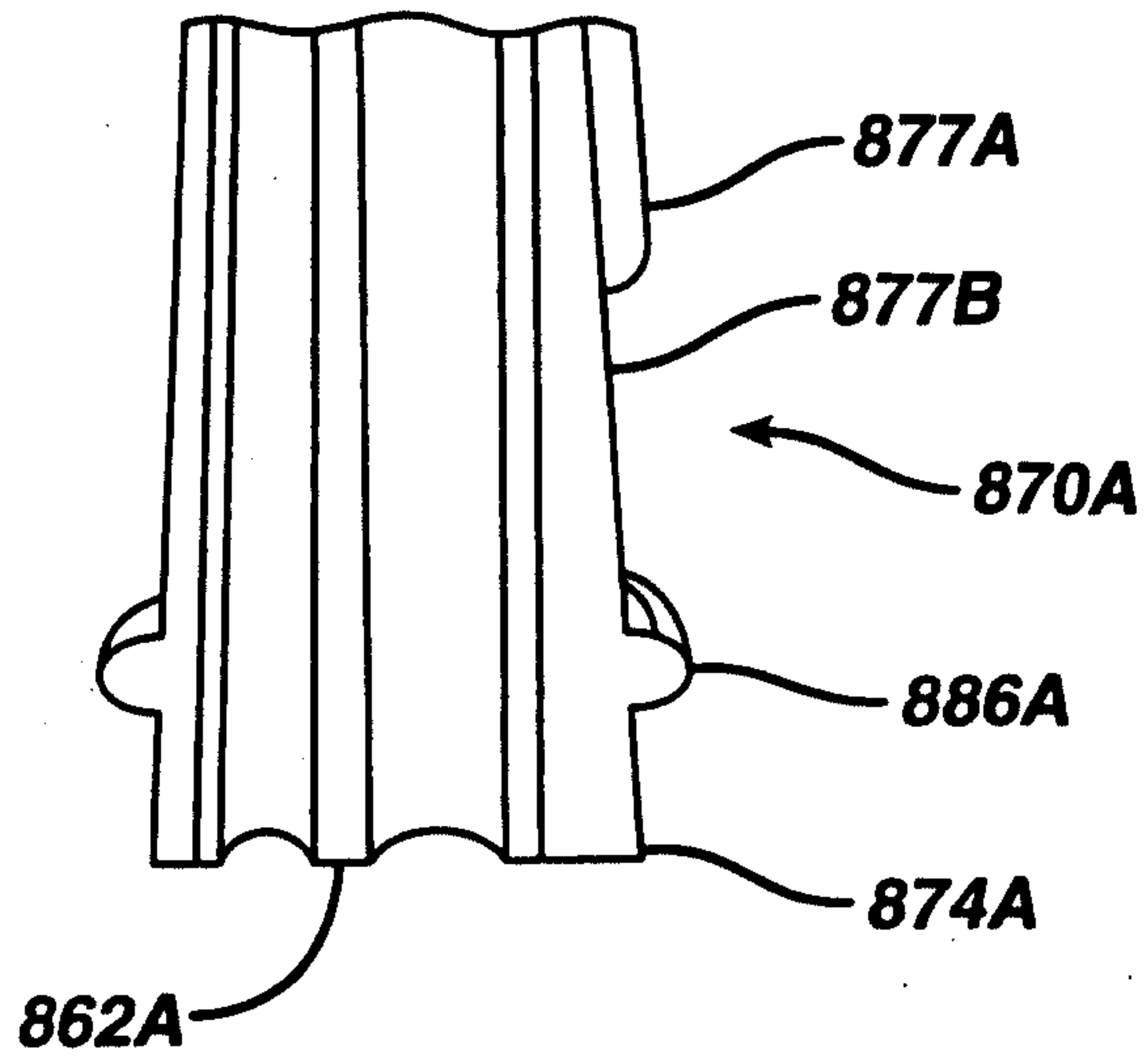


**FIG. 48**

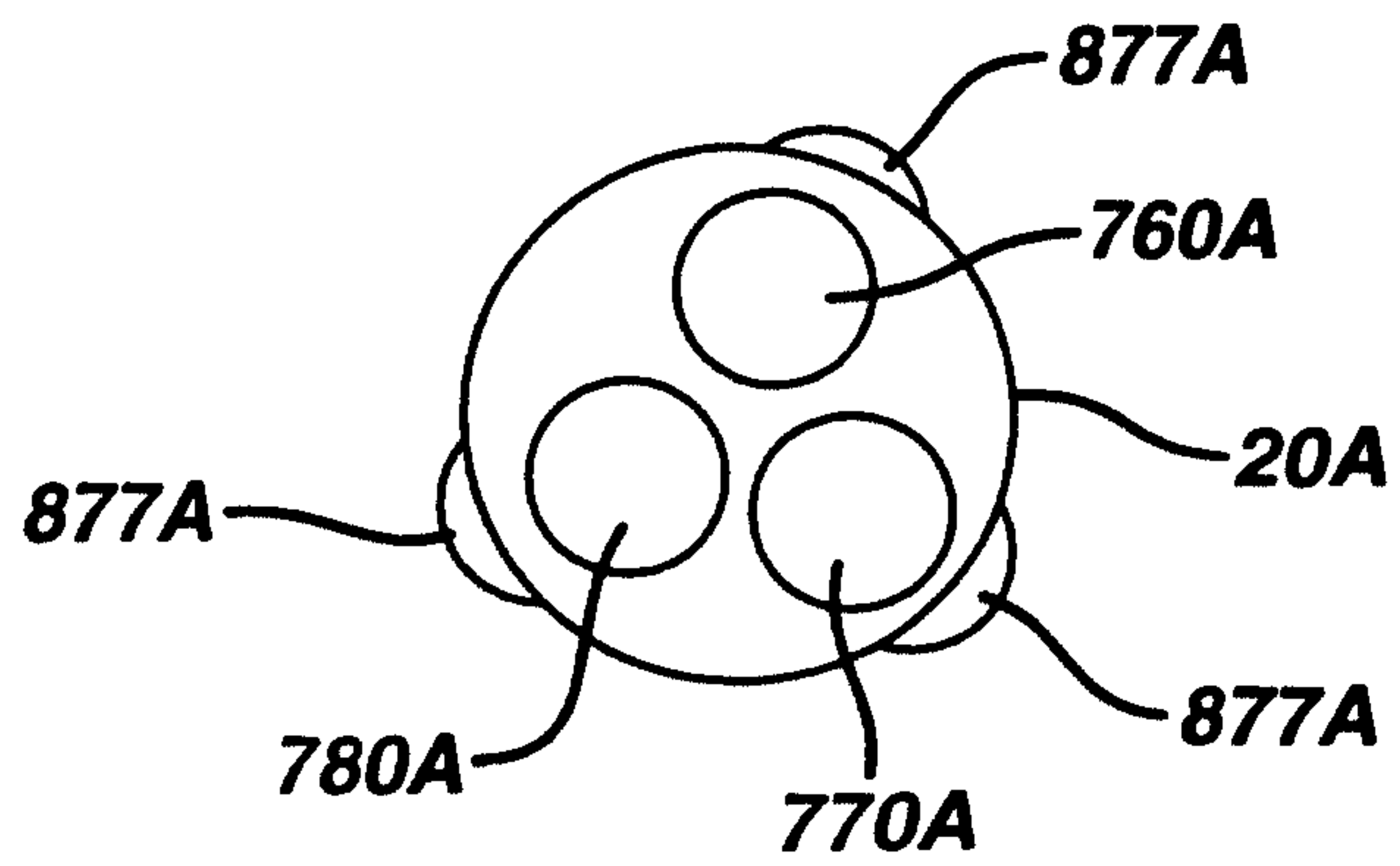


46/51

**FIG. 49**

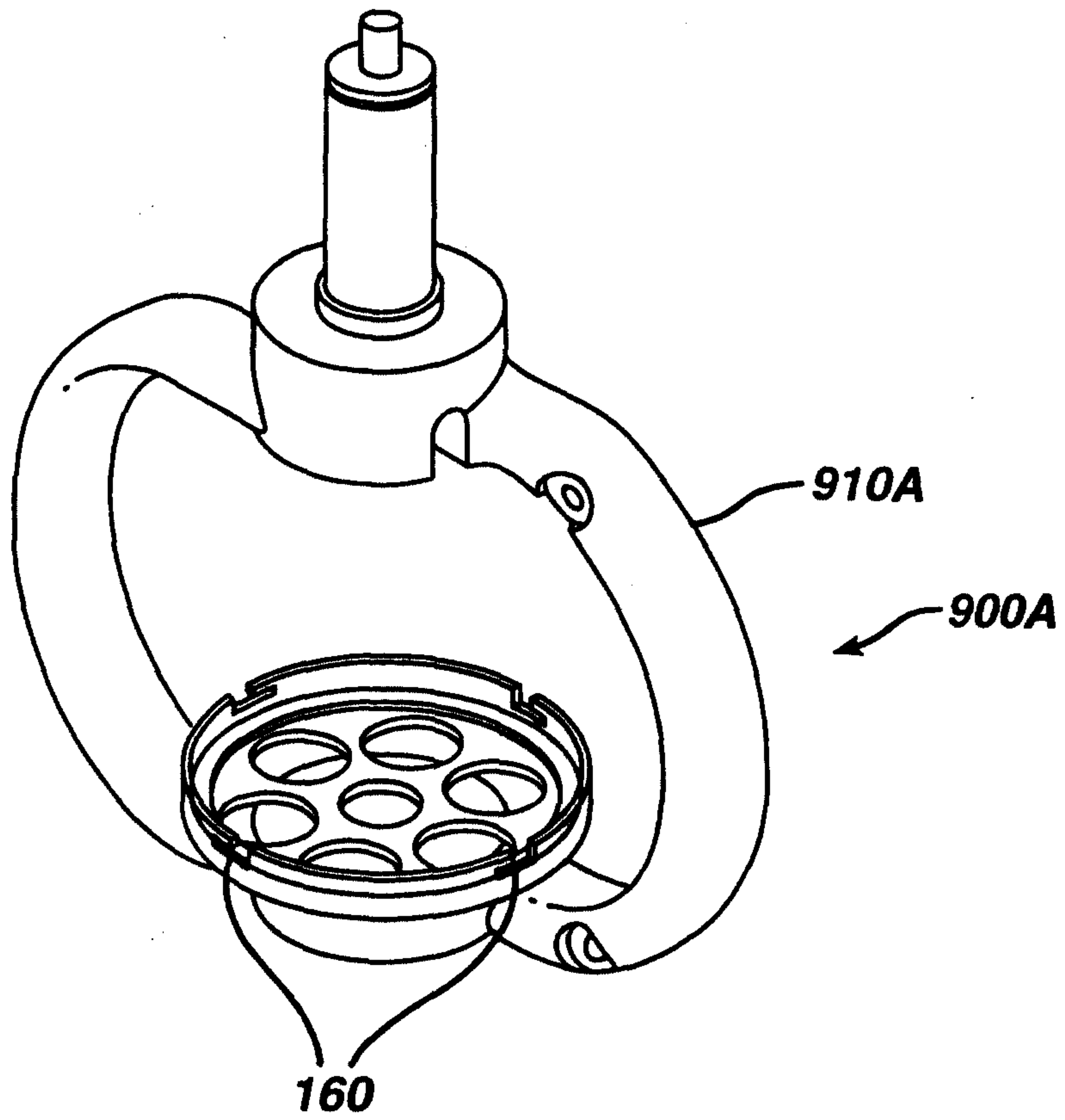


**FIG. 50**



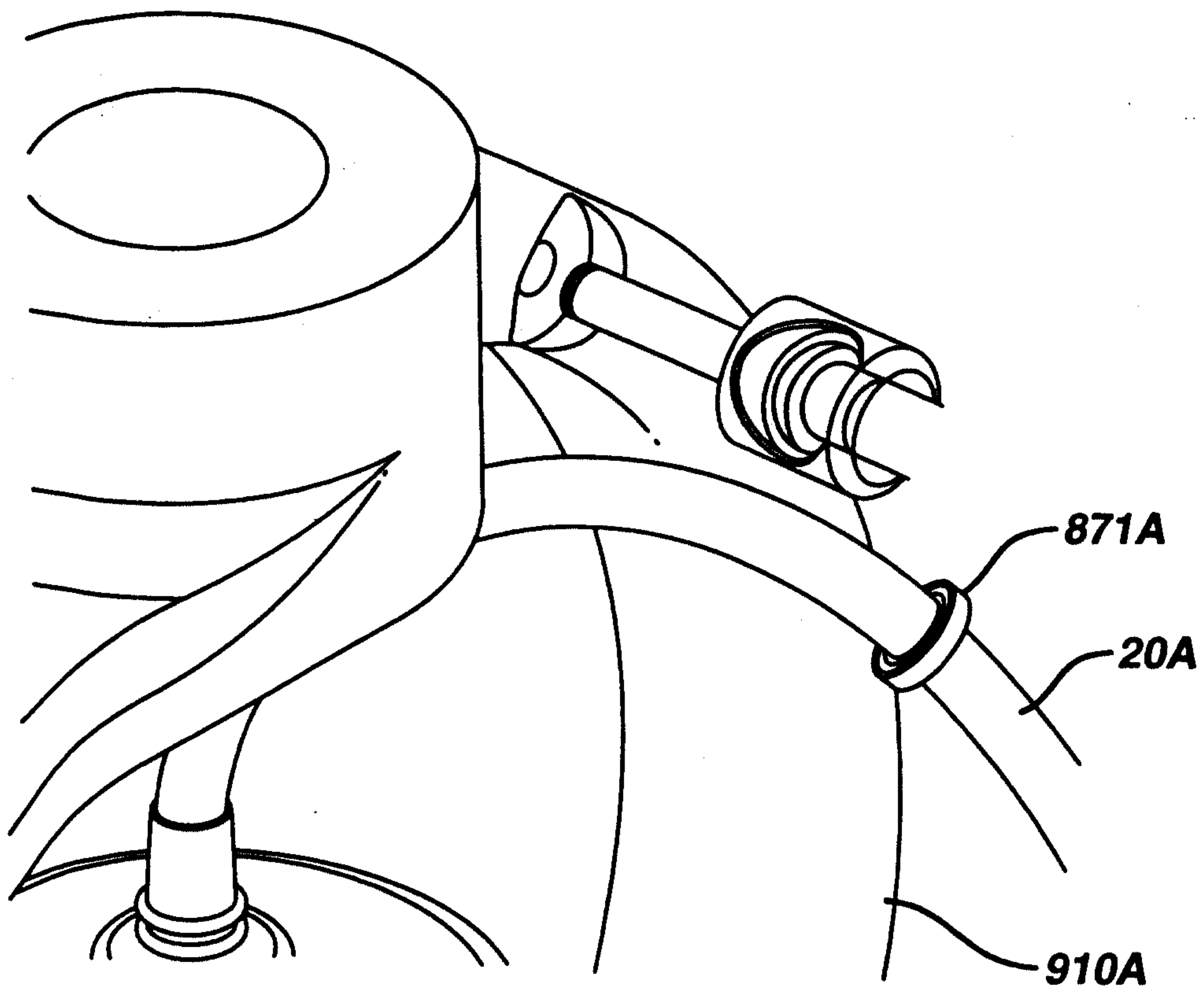
47/51

**FIG. 51**



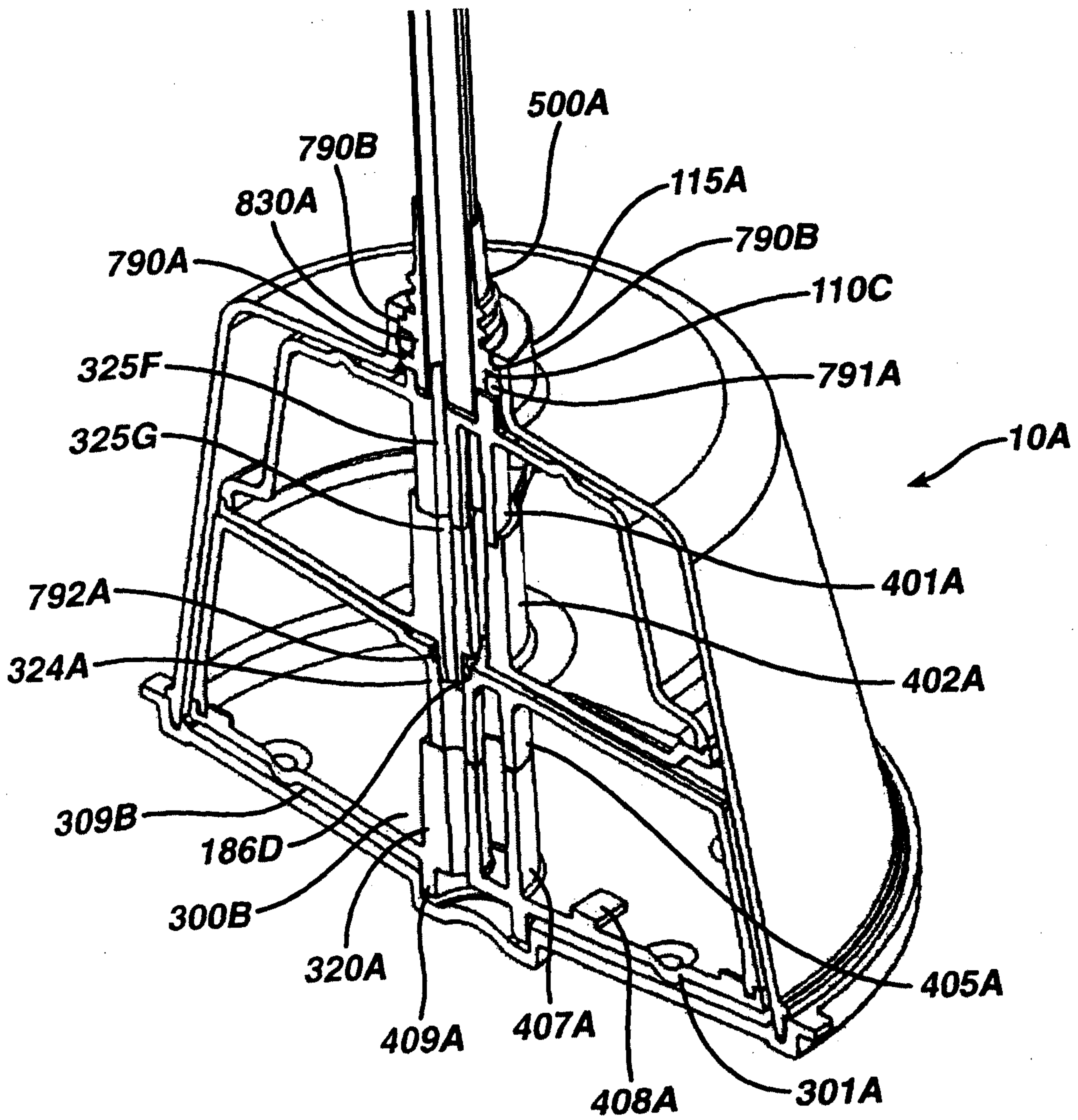
48/51

**FIG. 52**



49/51

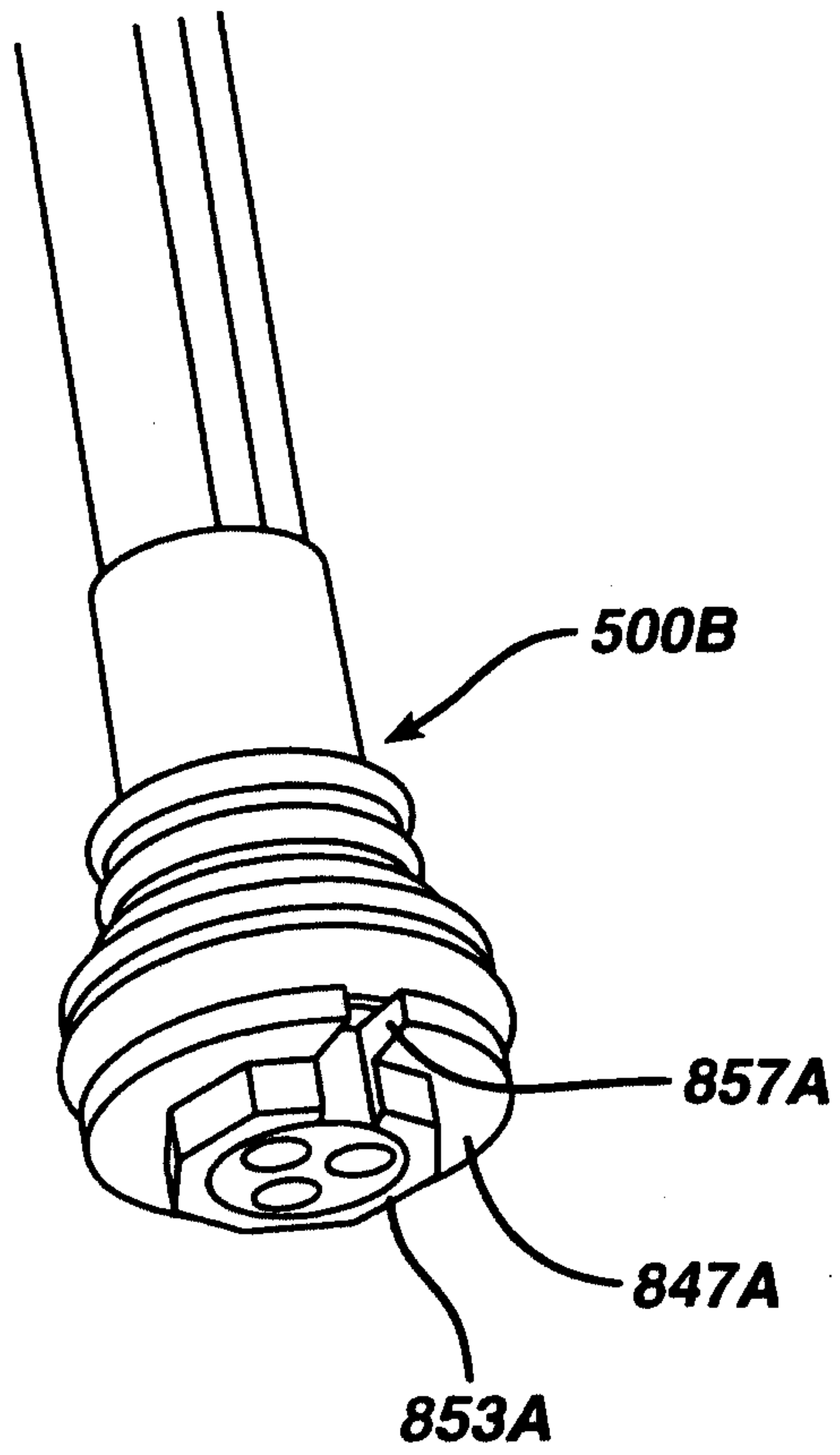
**FIG. 53**





50/51

**FIG. 54**



51/51

**FIG. 55**

