

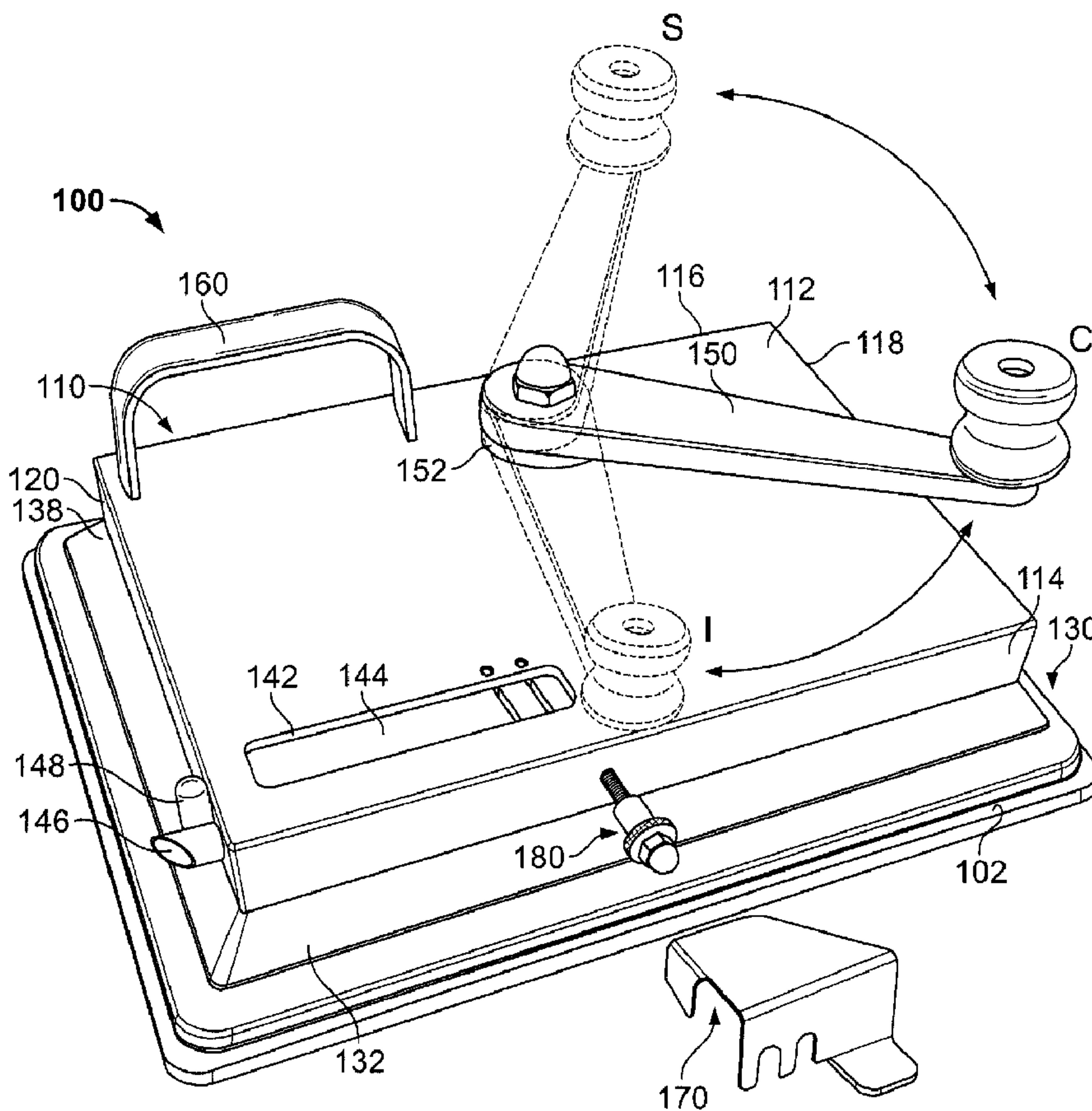

(22) Date de dépôt/Filing Date: 2007/02/13
 (41) Mise à la disp. pub./Open to Public Insp.: 2007/10/10
 (45) Date de délivrance/Issue Date: 2012/12/04
 (62) Demande originale/Original Application: 2 578 671
 (30) Priorité/Priority: 2006/04/10 (US11/401,126)

(51) Cl.Int./Int.Cl. *A24C 5/40* (2006.01)
 (72) Inventeur/Inventor:
 LIN, MEI, US
 (73) Propriétaire/Owner:
 REPUBLIC TOBACCO L.P., US
 (74) Agent: BERESKIN & PARR LLP/S.E.N.C.R.L.,S.R.L.

(54) Titre : APPAREIL A FABRIQUER DES CIGARETTES
 (54) Title: CIGARETTE-MAKING MACHINE



(57) Abrégé/Abstract:

In one embodiment, a cigarette-making machine of the tobacco-injecting type includes an improvement being a handgrip that provides improved ergonomics to a user of the machine. The handgrip is configured to project upward from a top surface of the

(57) **Abrégé(suite)/Abstract(continued):**

housing of the machine to position the user's hand distal from the compacting chamber and the hollow nipple, thereby preventing potential user injuries. Furthermore, the handgrip is configured on the top surface to provide the user with a convenient location to apply a downward force to the machine to prevent the machine from sliding on a surface without damaging components of the machine. In another embodiment, a cigarette-making machine of the tobacco-injecting type includes an improvement being an adjustable volume compacting chamber. The cigarette-making machine may include a volume-adjusting member that is configured to axially partition the compacting chamber into a tobacco-receiving portion and a vacant portion.

ABSTRACT

In one embodiment, a cigarette-making machine of the tobacco-injecting type includes an improvement being a handgrip that provides improved ergonomics to a user of the machine. The handgrip is configured to project upward from a top surface of the housing of the machine to position the user's hand distal from the compacting chamber and the hollow nipple, thereby preventing potential user injuries. Furthermore, the handgrip is configured on the top surface to provide the user with a convenient location to apply a downward force to the machine to prevent the machine from sliding on a surface without damaging components of the machine. In another embodiment, a cigarette-making machine of the tobacco-injecting type includes an improvement being an adjustable volume compacting chamber. The cigarette-making machine may include a volume-adjusting member that is configured to axially partition the compacting chamber into a tobacco-receiving portion and a vacant portion.

B&P File No. 4466-37

BERESKIN & PARR LLP/S.E.N.C.R.L., s.r.l.

CANADA

Title: CIGARETTE-MAKING MACHINE
Inventor(s): Mei Lin

CIGARETTE-MAKING MACHINE

FIELD OF THE INVENTION

[0001] This invention pertains generally to an injector-type cigarette-making machine, and, more particularly, to an improved injector-type cigarette-making machine and method of using the same.

BACKGROUND OF THE INVENTION

[0002] Injector-type cigarette-making machines are well known. U.S. Patent No. 2,731,971, to Kastner for "Cigarette Making Machine," issued January 24, 1956, discloses a cigarette-making machine for domestic use which compresses a portion of loose tobacco equivalent to one cigarette and then injects the compressed tobacco into a pre-formed cigarette tube by means of a plunger. The pre-formed empty cigarette tube is held at one end of a hollow nipple of the cigarette-making machine during the injection of the portion of tobacco. Once the compressed tobacco is fully injected into the pre-formed cigarette tube, it is released from the cigarette-making machine to be smoked or stored for later smoking thereof.

[0003] U.S. Patent Nos. 3,127,900 to Kastner for "Cigarette Machine," issued April 7, 1964, U.S. Patent No. 4,411,278 to Kastner for "Cigarette Making Machine," issued October 25, 1983, and U.S. Patent No. 6,557,560 to Kastner for "Cigarette Making Machine," issued May 6, 2003 provide various improvements to the cigarette-making machine described in U.S. Patent No. 2,731,971. For instance, U.S. Patent No. 3,127,900 discloses modifications to the above-described cigarette-making machine to adapt it for making cigarettes with pre-formed cigarette tubes having a filter. U.S. Patent No. 4,411,278 discloses a cigarette-making machine of the same general type as discussed above, but providing a new manufacturing method for substantially reducing the cost of production of the prior devices. All of the foregoing patents are expired. While the aforementioned patents provide various useful improvements for injector-type machines, which have achieved substantial commercial success, such machines still have problems that have remained unsolved until now.

[0004] One problem with the aforementioned machines is that none provides improved safety of operation and ergonomics for the user. As is well known, use of cigarette-making machines of the foregoing type sometimes occasionally results in injury to a user of the machine, particularly inexperienced users that are unfamiliar with operation of the machine

and have failed to read operating instructions and heed warnings provided therein. Referring now to FIG. 1, which illustrates use of a machine as illustrated in FIG. 8 of U.S. Patent No. 3,127,900, the cigarette-making machine 10 presents two potential hazards during use. After filling a compacting chamber 12, in which a compacting member 14 moves, with a quantity of tobacco, a user grasps the ejector handle 16, which is oriented at the starting position, with a first hand. The user then places his or her other hand on the machine 10 to exert a downward force thereon for preventing the machine 10 from sliding on a surface during clockwise rotation of the ejector handle 16. As shown, the user often positions his or her hand on a corner of the machine 10 proximate the compacting chamber 12 and a hollow nipple 18, through which an injector spoon (e.g., 230, FIG. 7) projects. In the illustrated hand position, the user may be subject to a pinching injury from the compacting member 14 and/or a laceration-type injury from the injector spoon. To this end, cigarette-making machines of the injector type are sold or otherwise provided with warnings such as stickers or decals placed on the machine and operating instructions for educating and alerting inexperienced users as to proper machine operation.

[0005] While warnings have been generally effective in substantially reducing user injuries, the warnings have caused many users to operate the machines improperly, resulting in broken or otherwise malfunctioning machines. In particular, many users noticing the warnings tend to overcautiously operate the machine - solely with a hand on the ejector handle 16. These overcautious users typically rotate the handle 16 clockwise while exerting a downward force on the handle 16 to prevent the machine 10 from sliding on a surface during clockwise rotation of the ejector handle 16. While exerting the downward force on the handle 16 does prevent the machine 10 from sliding, the downward force undesirably causes additional wear and tear on the machine components (e.g., rotating shaft, shaft bushing, linkage assembly, etc.) that couple the handle 16 with the compacting member 14. Many manufacturers of cigarette-making machines offer a warranty for repairing/replacing damaged machines at no cost to the user, which results in lost revenue. To this end, it would be desirable to provide a machine with improved ergonomics for maximizing user safety and minimizing improper machine operation.

[0006] Another well known challenge with injector-type cigarette-making machines is adjustability for making cigarettes of different sizes. Prefabricated paper tubes are available in myriad sizes and styles. For example, "100mm" size, "king" size and "regular" size paper tubes are available in filter tip and "straight" (i.e., unfiltered) styles, each tube differing slightly

in length and/or diameter from another tube. As can be appreciated, if the injector-type cigarette-making machine is unable to adapt to paper tubes of various sizes, a user is faced with the problems of either injecting too much or too little tobacco into a tube, resulting in an unsuitable cigarette. In an attempt to adapt injector-type cigarette-making machines for filling paper tubes of two or more sizes, such machines have been provided with an adjustment lever 20, as shown in FIG. 1. When the adjustment lever 20 is moved by the user, the distance that the injector spoon (e.g., 230, FIG. 7) projects from the hollow nipple 18 is changed. Although the adjustment lever 20 of machine 10 should work at least theoretically, users of machines having an adjustment lever 20 have found that the adjustment lever 20 does not facilitate filling paper tubes of two or more different sizes because the adjustment lever 20 does not adjust the volume of the compacting chamber 12. Thus, to adapt the machine 10 to fill various sized paper tubes, a user needs to vary the amount of tobacco that he or she metes out into the compacting chamber 12. Furthermore, a user may need to position, arrange or otherwise configure the tobacco in the compacting chamber 12. For example, a user may dispose the tobacco in the central and left (i.e., proximate the hollow nipple 18) portions of the chamber 12 for suitable compaction and insertion into a short paper tube. Since such machines require considerable user intervention, it would be desirable to provide a machine with improved adjustability for adapting to various sized paper tubes.

BRIEF SUMMARY OF THE INVENTION

[0007] In one aspect, a cigarette-making machine that overcomes the foregoing problems is provided. In one embodiment, a cigarette-making machine of the tobacco-injecting type includes an improvement being a handgrip that provides improved ergonomics to a user of the machine. The handgrip is configured to project upward from a top surface of the housing of the machine to position the user's hand distal from the compacting chamber and the hollow nipple. Furthermore, the handgrip is configured on the top surface to provide the user with a convenient location to apply a downward force to the machine to prevent the machine from sliding on a surface without damaging components of the machine. In another embodiment, a cigarette-making machine of the tobacco-injecting type includes an improvement being an adjustable volume compacting chamber. The cigarette-making machine may include a volume-adjusting member that is configured to axially partition the compacting chamber into a tobacco-receiving portion and a vacant portion. To cooperate with the volume-adjusting member for axially partitioning the compacting chamber, the compacting member may include at least one slot that is

substantially parallel to a direction along which the compacting member moves. In another aspect, a method of using an improved cigarette-making machine is provided.

BRIEF DESCRIPTION OF THE DRAWINGS

- [0008] FIG. 1 shows a prior art injector-type cigarette-making machine;
- [0009] FIG. 2 shows a perspective view of an improved injector-type cigarette-making machine according to one embodiment;
- [0010] FIG. 3 shows a close-up view of the compacting chamber of the embodiment of FIG. 2;
- [0011] FIG. 4 shows a top plan view of the embodiment of FIG. 2;
- [0012] FIG. 5 shows a front elevation view of the embodiment of FIG. 2;
- [0013] FIGS. 6A-C respectively show a top plan view, a side elevation view and a front elevation view of the volume-adjusting member shown in FIG. 2; and
- [0014] FIG. 7 shows a bottom view of the embodiment of FIG. 2, partially illustrating internal components.

DETAILED DESCRIPTION OF THE EMBODIMENTS

[0015] Referring now to the Figures, an improved cigarette-making machine is provided. As shown in FIG. 2, one embodiment of an improved cigarette-making machine 100 is of the injector-type where a supply of tobacco for a single cigarette is compacted within a compacting chamber and is then injected into a preformed paper cigarette tube by means of an injector. The machine 100 includes a generally rectangular-shaped housing that includes an upper portion 110 and a lower portion 130. The upper and lower portions 110, 130 may be made of any suitable material such as metal, plastic, etc. The upper portion 110 includes a generally planar top surface 112 and front, rear, right and left sides 114, 116, 118, 120, respectively, depending downward and generally perpendicular to the top surface 112. The lower portion 130, as shown, also include front, rear, right and left sides 132, 134, 136, 138 depending downward and obliquely outward from the front, rear, right and left sides 114, 116, 118, 120, respectively. As such, the top surface 112 and sides

114-120 of the upper portion 110 and sides 132-138 of the lower portion 130 define an internal cavity for housing moving component parts (e.g., linkage assembly, cam, operating arm, injector, etc.) of the machine 100. Component parts of the machine 100 are well known (see, for example, the patents discussed hereinabove) and, therefore, are not discussed here in detail for brevity. As shown, the lower portion 130 may include a base 102 that may be removably attached to a bottom of the lower portion 130 for the purpose of providing access to the moving component parts to facilitate cleaning, maintenance, repair, etc. The base 102 may be made of any suitable material, but it is preferred that the base 102 be a non-skid material such as rubber or the like to minimize movement (e.g., sliding) of the machine 100 on a surface during use.

[0016] As further shown in FIG. 2, the top surface 112 includes an aperture 142 defining an opening to a compacting chamber (FIG. 3, 140) in which a compacting member 144 translates to compress a quantity of tobacco that is disposed in the chamber 140. The machine 100 includes on the left side 120 of the upper portion 110 proximate the front side 114 a hollow nipple 146 in communication with the compacting chamber 140. Furthermore, a clamp member 148 is configured proximate the nipple 146. As is known, a compressed, generally cylindrical tobacco portion is moved from the compacting chamber 140 by an injector (FIG. 7, 230) through the hollow nipple 146 and into a prefabricated paper cigarette tube that is disposed on the nipple 146. The clamp member 148 cooperates with the nipple 146 to retain the prefabricated paper cigarette tube on the nipple 146 during tobacco insertion. The machine 100, as shown, also includes on the top surface 112 an actuator 150 and a handgrip 160. The actuator 150 rotates through an angle of approximately 180 degrees in a plane above the top surface 112 to drive the internal component parts that couple the actuator 150 with the compacting member 144.

[0017] As shown, the actuator 150 is moved in an arcuate path from its starting orientation (i.e., projecting generally rearward and rightward), which is indicated in FIG. 2 by a dashed-line representation labeled "S", to its compacting orientation (i.e., projecting generally rightward and slightly forward), which is indicated by a solid-line representation labeled "C", and then to its ejecting orientation (i.e., projecting generally forward and slightly leftward), which is indicated by a dashed-line representation labeled "I". When the actuator 150 is in the starting orientation S, the compacting member 144 is fully retracted (i.e., translated rearward) to permit loading of the compacting chamber 140 with tobacco. As the actuator 150 is rotated from the starting orientation S to the compacting orientation

C, the compacting member 144 moves forward (i.e., toward the front side 114) to compress the tobacco in the compacting chamber 140. Next, as the actuator 150 is further rotated from the compacting orientation C to the injecting orientation I, the compacting member 144 remains generally stationary and an injector (not shown) translates leftward through the compacting chamber 140 and hollow nipple 146 to move the compressed tobacco into the paper cigarette tube disposed on the nipple 146. By moving the actuator 150 from the injecting position I in an opposite (i.e., counterclockwise) direction, the injector is retracted into the internal cavity so that the completed cigarette may be removed from the nipple 146, and the compacting member 144 is translated rearward to ready the machine 100 for making another cigarette.

[0018] One can appreciate that, despite the presence of the optional slip-minimizing (e.g., rubber) base 102, the machine 100 may still undesirably move on a surface during rotation of the actuator 150. To this end, the handgrip 160 is provided so that a user can apply a downward force to the machine 100 to obviate movement of the machine 100 during cigarette-making without causing damage to the machine 100 (e.g., the shaft bushing 152, the internal component parts, etc.), which generally occurs when a downward force is applied to the actuator 150. Furthermore, the handgrip 160 is configured on the top surface 112 to provide improved ergonomics to a user of the machine 100. Moreover, the handgrip provides a convenient means to carry and transport the machine 100.

[0019] As best illustrated in FIGS. 2 and 4, the handgrip 160 is configured in the left, rear corner of the top surface 112, projecting upward therefrom. The handgrip 160 is configured to the left of the actuator 150, being generally parallel with the front and rear sides 114, 116, such that the user is induced to place his or her other hand (i.e., the user's hand not rotating the actuator 150) distal from the compacting member 144, distal from the hollow nipple 146, and distal from the arcuate path of the actuator 150. Although the handgrip 160 is illustrated as being configured generally parallel with the front and rear sides 114, 116, the handgrip 160 may be configured otherwise, for example, obliquely or generally parallel with the right and left sides 118, 120. As can be appreciated from FIGS. 2, 4 and 5, in the illustrated embodiment of the improved cigarette-making machine 100, the handgrip 160 is a handle, but the handgrip 160 may be a knob, or other rigid or semi-rigid member that is known in the art for applying a force, holding or carrying an object. As shown in FIGS. 2, 4 and 5, the illustrated handgrip 160 is a generally elongated U-, C- or D-shaped handle that is configured to be held and gripped with the fingers of the hand, but the

handgrip 160 may be shaped otherwise. For example, the handgrip 160 may additionally include an ergonomic treatment known in the art (e.g., finger grooves, padding, etc.) for improving gripping of the handgrip 160 and alleviating fatigue of the hand, wrist and arm. The handgrip 160 may be integrally formed or unitary with the housing (e.g., the upper portion 110) or may be affixed thereto, for example with fasteners such as screws, bolts, pins and the like. In some embodiments, the handgrip 160 may be removable.

[0020] Referring now to FIGS. 2-6, the cigarette-making machine 100 may include a further improvement being a compacting chamber 140 with a user-adjustable volume. As shown in FIG. 2, the cigarette-making machine may include a volume-adjusting member 170 that is movable on the machine 100 to vary the volume of the compacting chamber 140. As shown in FIG. 2, the volume-adjusting member 170 may additionally be removable from the machine 100. The machine 100 includes a securing mechanism 180 that is configured to couple the volume-adjusting member 170 to the machine 100. Furthermore, the securing mechanism 180, the compacting member 144 and the volume-adjusting member 170 may, as described hereafter, cooperate to facilitate moving the volume-adjusting member 170 axially (i.e., horizontal direction generally parallel to the front and rear sides 114, 116) in the compacting chamber 140 to provide a desired volume for accepting a predetermined quantity of tobacco.

[0021] As best shown in FIG. 3, the compacting member 144 includes a left slot 144a and a right slot 144b, the slots 144a, 144b being spaced apart a predetermined axial, horizontal distance and extending rearward and generally perpendicular from the compacting member's curved (e.g., hemispherical) compacting surface 145. Although the compacting member 144 is illustrated as including two slots 144a, 144b, the compacting member 144 may include fewer or additional slots to provide additional or less volume adjustability. In an example, the compacting member 144 may include only one slot so that the machine 100 is configured to fill two different sizes of paper cigarette tubes – a first size when the volume-adjusting member is received in the single slot and a second size when the volume-adjusting member is removed from the single slot. As further shown in FIG. 3, posts 113a, 113b are configured in the slots 144a, 144b, respectively to extend vertically from the top surface 112 to a floor of the compacting chamber 140 to prevent the compacting member 144 from moving axially and binding in the chamber 140 (e.g., during compacting of a portion of tobacco). Although the posts 113a, 113b are illustrated to be substantially cylindrically-shaped, the posts 113a, 113b may be shaped otherwise, for

example, as rectangular or square bars or tubes. As can be appreciated from FIGS. 2-4, the slots 144a, 144b are configured to receive a portion of the volume-adjusting member 170 when the volume-adjusting member 170 is coupled to the machine 100 via the securing mechanism 180. That is, a portion of the volume-adjusting member 170 is configured for insertion into the compacting chamber 140 such that the volume-adjusting member 170 cooperates with at least one of the slots 144a, 144b to axially partition the chamber 140.

[0022] As best illustrated in FIGS. 6A-C, the volume-adjusting member 170 may be formed or machined of a suitable rigid material such as metal, plastic or the like. For example, the volume-adjusting member 170 may be formed as a one-piece member from a steel plate or sheet. As shown, the volume-adjusting member 170 includes a generally planar top surface 172 (FIG. 6A), a side surface 174 (FIG. 6B) that depends downward from a left edge of the top surface 172, and a front surface 176 (FIG. 6C) that depends downward from a front edge of the top surface 172. As best illustrated in FIG. 4, the top surface 172 is configured to cover a top (right-hand) portion of the aperture 142 when the side surface 174 is disposed in the compacting chamber 140. As further illustrated in FIG. 4, the side surface 174, when disposed in the compacting chamber 140, is operative to provide a partition portion that axially partitions the compacting chamber 140 into a tobacco-receiving (left-hand) portion and a vacant (right-hand) portion that is covered by the top surface 172. The side surface 174 is configured to have a width substantially similar to a width of the aperture 142 and a height that substantially extends from a floor of the compacting chamber 140 to the top surface 112. As shown in FIG. 6C, the front surface 176 of the volume-adjusting member 170 includes two spaced-apart vertical notches - a left notch 176a and a right notch 176b, and a forward-projecting portion 177 that facilitates grasping, handling or otherwise moving the volume-adjusting member 170, particularly when it is coupled to the machine 100. Although the front surface 176 includes two spaced apart vertical notches 176a, 176b, the front surface 176 may include fewer or additional notches to substantially correspond with the number of slots in the compacting member 144. For example, in the previous example in which the compacting member 144 includes only one slot so that the machine 100 is configured to fill two different sizes of paper cigarette tubes, the volume-adjusting member 170 includes only one notch. As best illustrated in FIG. 5, the notches 176a, 176b are configured to couple with the securing mechanism 180, such that the side surface 174 is aligned in the slots 144a, 144b and the volume-adjusting member 170 is prevented from moving in the axial direction.

[0023] FIGS. 4 and 5 illustrate the volume-adjusting member 170 coupled to the machine 100 with the right notch 176b being disposed on the securing mechanism 180 such that the volume-adjusting member 170 is configured in a leftmost orientation. When the volume-adjusting member 170 is configured in the leftmost orientation, as shown, the side surface 174 is received in left slot 144a to minimize the volume of the tobacco-receiving portion of the compacting chamber 140. The leftmost orientation of the volume-adjusting member 170 may correspond with a user filling a paper cigarette tube of the “regular” size. Similarly, when the volume-adjusting member 170 is coupled to the machine 100 with the left notch 176a being disposed on the securing mechanism 180, the volume-adjusting member 170 is configured in a rightmost orientation such that the side surface 174 is received in right slot 144b to slightly increase the volume of the tobacco-receiving portion of the compacting chamber 140 relative to the leftmost orientation. The rightmost orientation of the volume-adjusting member 170 may correspond with a user filling a paper cigarette tube of the “king” size. Furthermore, when the volume-adjusting member 170 is removed from the machine 100, the full volume of the compacting chamber 140 is available for filling with tobacco such that a user may fill a “100mm” size paper cigarette tube. Although the compacting member 140 is configured with two slots 144a, 144b that correspond with respective notches 176b, 176a of the volume-adjusting member 170 so that three sizes of paper cigarette tubes may be filled, alternatively the compacting member 140 may be configured with one slot and the volume-adjusting member 170 may be configured with one notch so that two sizes of paper cigarette tubes may be filled (i.e., a smaller sized paper tube may be filled using the volume-adjusting member 170 and a larger sized paper tube may be filled by removing the volume-adjusting member 170 from the machine 100).

[0024] As shown in FIGS. 2, 4 and 5, the securing mechanism 180 projects forward from the front side 114, intermediate the right and left sides 118, 120. One embodiment of the securing mechanism 180, as shown, includes a fastener 182 extending through the front side 114 and having a threaded portion 184 with a head 186 (FIG. 7) at a first end (i.e., within the internal cavity). A first nut 188, which is illustrated as an acorn cap nut, is disposed on a second end of the fastener 182 outside the housing and distal the head 186, and a second nut 190, which is illustrated as a knurled nut, is disposed on the threaded portion 184 and movable between the first nut 188 and the front side 114. As can be appreciated, although the first nut 188 is provided to prevent the second nut 190 from being removed from the fastener 182, alternatively the first nut 188 may be omitted. By moving the knurled nut 190 rearward and forward on the threaded portion 184, a user may

respectively secure (i.e., clamp) and release the volume-adjusting member 170 against the front side 114. Although one embodiment of the securing mechanism 180 is configured as described, other mechanical devices known in the art may be suitably employed for removably and/or adjustably moving the volume-adjusting member 170 axially in the compacting chamber 140. For example, the securing mechanism 180 may be a latch, a catch, or the like.

[0025] Referring now to FIG. 7, a plan view of the internal cavity of the machine 100 is provided, partially illustrating the internal component parts. As shown, an arm 210 is connected at its first end to a shaft 200, for pivotal movement therewith, which connects to the actuator 150 above the top surface 112. A link 220 is pivotally connected at one end to a second end of the arm 210 distal from the shaft 200. A second end of the link 220 is pivotally connected to the injector 230. As the actuator 150 is rotated from the compacting orientation (FIG. 2, indicated by C) to the injecting orientation (FIG. 2, indicated by I), the arm 210 and link 220 articulate and translate the injector spoon 230 through the compacting chamber 140 and hollow nipple 146 to fill a paper cigarette tube, which is disposed on the nipple 146, with compacted tobacco. As is known in various conventional injector-type cigarette-making machines (e.g., the machine illustrated in FIG. 1), a tube-retaining lever 240 is spring-biased and coupled with the clamp member 148 for the purpose of holding a paper cigarette tube on the hollow nipple 146 during injection of tobacco into the tube. Furthermore, in such conventional machines, the tube-retaining lever 240 (or a member coupled therewith) provides a stop to prevent over-rotation of the actuator 150 (i.e., moving the actuator 150 past the injecting orientation I) that could cause the link 220 from over-extending the injector 230 into the paper tube since such over-rotation may, for example, cause damage to a filter end of the tube. In one embodiment of the machine 100, to prevent over-rotation of the actuator 150 (i.e., moving the actuator 150 past the injecting orientation I), the fastener 182 is configured on the front side 114 intermediate the left and right sides 120, 118 such that the head 186 of the fastener 182 provides a positive stop for the actuator 150 instead of the tube-retaining lever 240 providing the stop. That is, referring to the illustrated embodiment of FIG. 7, the head 186 projects inward to catch the second end of the link 220 as shown. In this way, the head 186 catches the second end of the link 220 to prevent the arm 210 from contacting the tube-retaining lever 240, since contact between the arm 210, link 220 and tube-retaining lever 240 could potentially cause the paper cigarette tube from being released from the nipple 146 prematurely or cause the arm 210, link 220 and the lever

240 to bind together resulting in improper operation and/or damage to the internal component parts.

[0026] In another aspect, a method of using the improved injector-type cigarette-making machine is provided. Initially, the machine should be prepared or readied by the user to accept a portion of tobacco, for example, by rotating the actuator to be at the starting orientation. A paper cigarette tube is disposed on the hollow nipple and a portion of tobacco is disposed in the compacting chamber. A user places a first hand (e.g., the user's right hand) on the actuator and places a second hand (e.g., the user's left hand) on the handgrip. The user may apply a downward force on the handgrip and rotate (e.g. in a horizontal plane in a clockwise direction) the actuator with the user's other hand. During rotation of the actuator, the user may intermittently or substantially continuously apply the downward force on the handgrip to prevent slipping of the machine until the paper cigarette tube is filled with tobacco, making a completed cigarette.

[0027] In some instances, the user may desire to make cigarettes of various sizes. In these instances, the user first determines a size of the paper cigarette tube that is disposed on the hollow nipple. Next, the user selects or otherwise adjusts, according to the determined size of the paper cigarette tube, a volume for the compacting chamber, and fills the selected or otherwise adjusted volume with tobacco. The user then may follow the above-described process of: placing his or her hands on the actuator and the handgrip; applying a downward force to the handgrip; and rotating the actuator. To select a volume for the compacting chamber, the user may dispose or otherwise configure a volume-adjusting member in the compacting chamber to axially partition the chamber, thereby creating a tobacco-receiving volume and a vacant volume. In some embodiments of the machine, to maximize the tobacco-receiving volume, the user may remove the volume-adjusting member from the compacting chamber.

[0028] Various embodiments of the invention are described herein. It should be understood that the illustrated embodiments are exemplary only, and should not be taken as limiting the scope of the invention.

WHAT IS CLAIMED IS:

1. A cigarette-making machine comprising:
 - a housing including a top surface having an aperture;
 - an actuator that moves in an arcuate path above the top surface;
 - a compacting chamber within in the housing, the compacting chamber in communication with the aperture;
 - a compacting member disposed in the compacting chamber and coupled with the actuator, the compacting member translating according to movement of the actuator;
 - a hollow nipple configured on the housing proximate the aperture, the hollow nipple in communication with the compacting chamber; and
 - a volume-adjusting member insertable into the compacting chamber, the volume-adjusting member configured to partition the compacting chamber into a vacant volume and a tobacco-receiving volume proximate the hollow nipple.
2. The cigarette-making machine of claim 1 further comprising a securing mechanism configured to retain the volume-adjusting member at a position along a length of the compacting chamber.
3. The cigarette-making machine of claim 2 wherein the compacting member comprises:
 - a compacting surface extending along a length of the compacting chamber; and
 - at least one slot extending generally perpendicular from the compacting surface, wherein the volume-adjusting member includes a partition portion configured to be received in the at least one slot.
4. The cigarette-making machine of claim 3 wherein the volume-adjusting member includes at least one notch configured to cooperate with the securing mechanism to align the partition portion in the at least one slot.

5. The cigarette-making machine of claim 2 wherein the securing mechanism comprises:

a fastener configured to project through the housing proximate an end of the aperture, the fastener including a threaded portion and a head at one end of the threaded portion within the housing; and

a nut disposed on the threaded portion, the nut configured to clamp the volume-adjusting member to the housing.

6. The cigarette-making machine of claim 5 wherein the head is configured to provide a stop to prevent movement of the actuator past an end of the arcuate path.

7. The cigarette-making machine of claim 1 further comprising a handgrip affixed to the housing, the handgrip with an opening for receiving a user's fingers and configured distal from the arcuate path, the compacting chamber and the hollow nipple.

8. The cigarette-making machine of claim 7 wherein the handgrip is configured on a left, rear portion of the top surface.

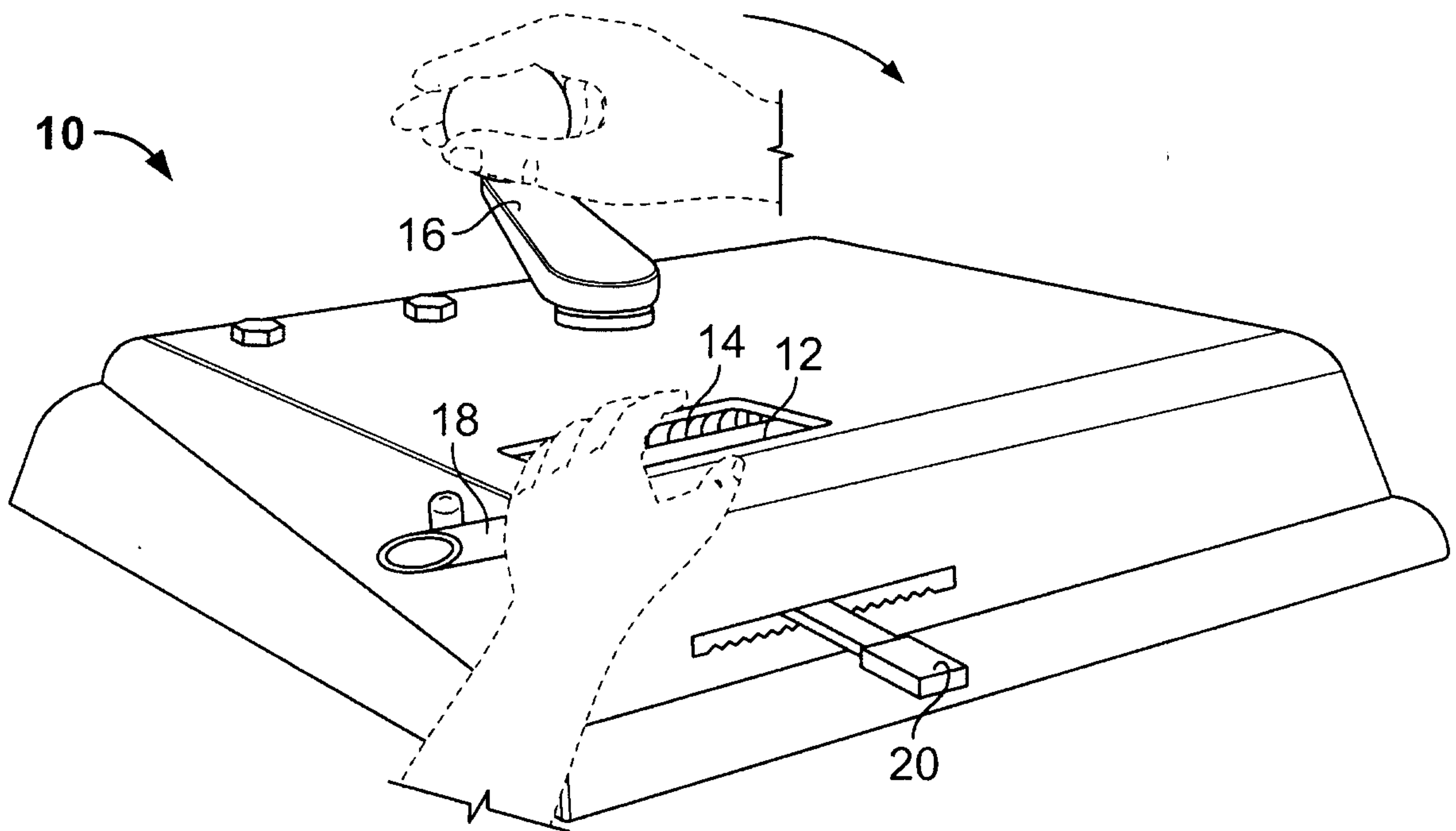

FIG. 1
(Prior Art)

2/7

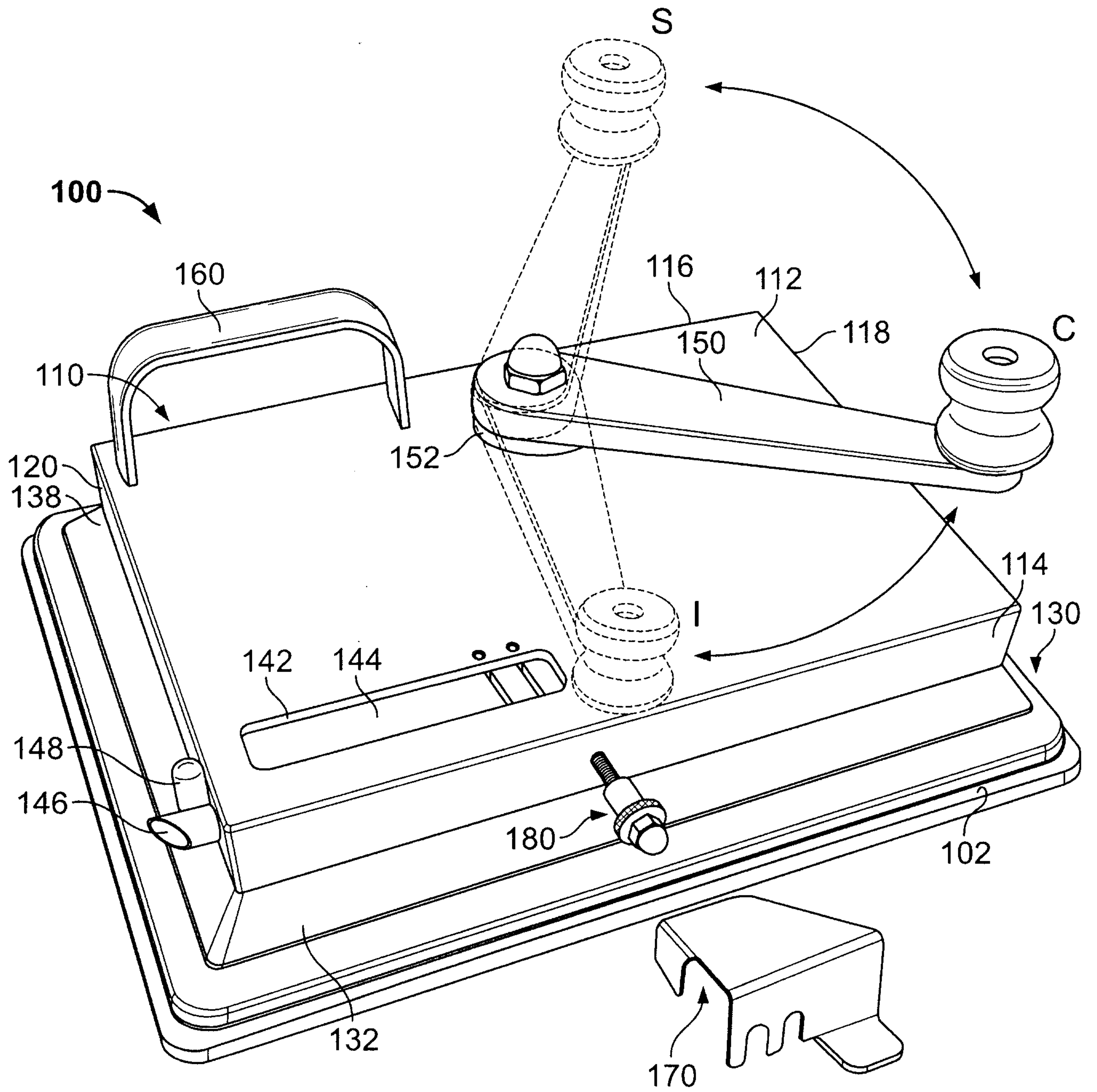

FIG. 2

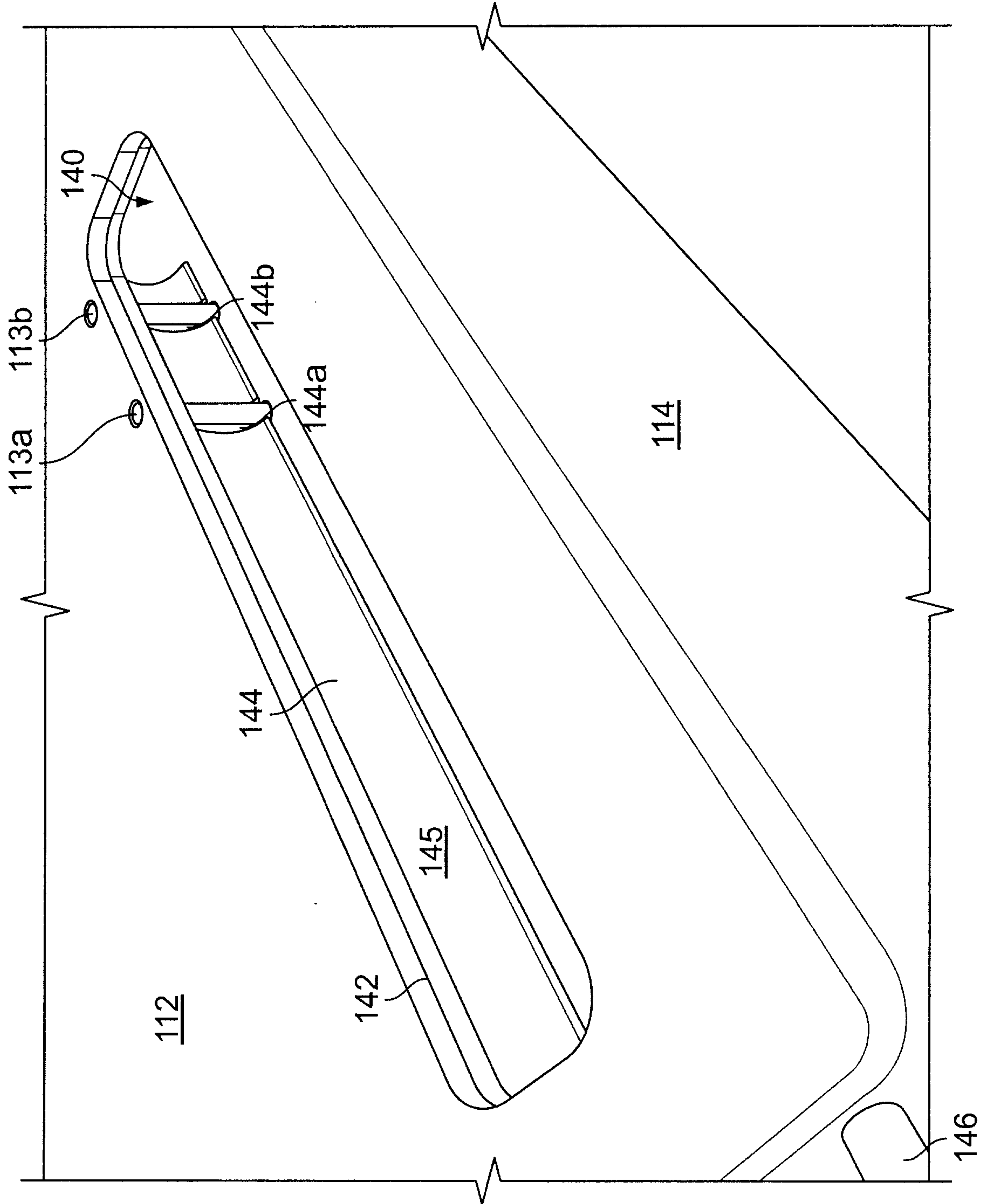

FIG. 3

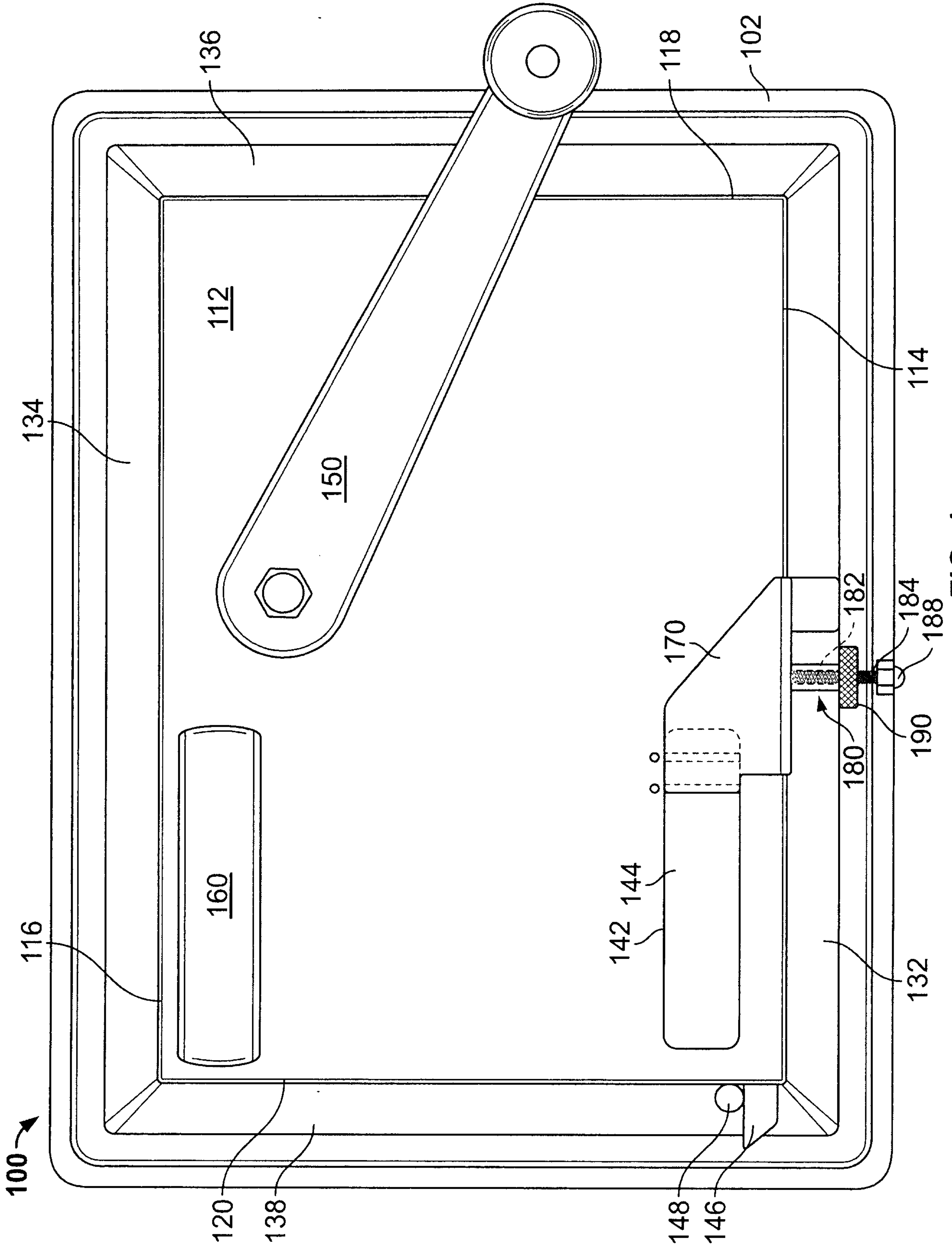

FIG. 4

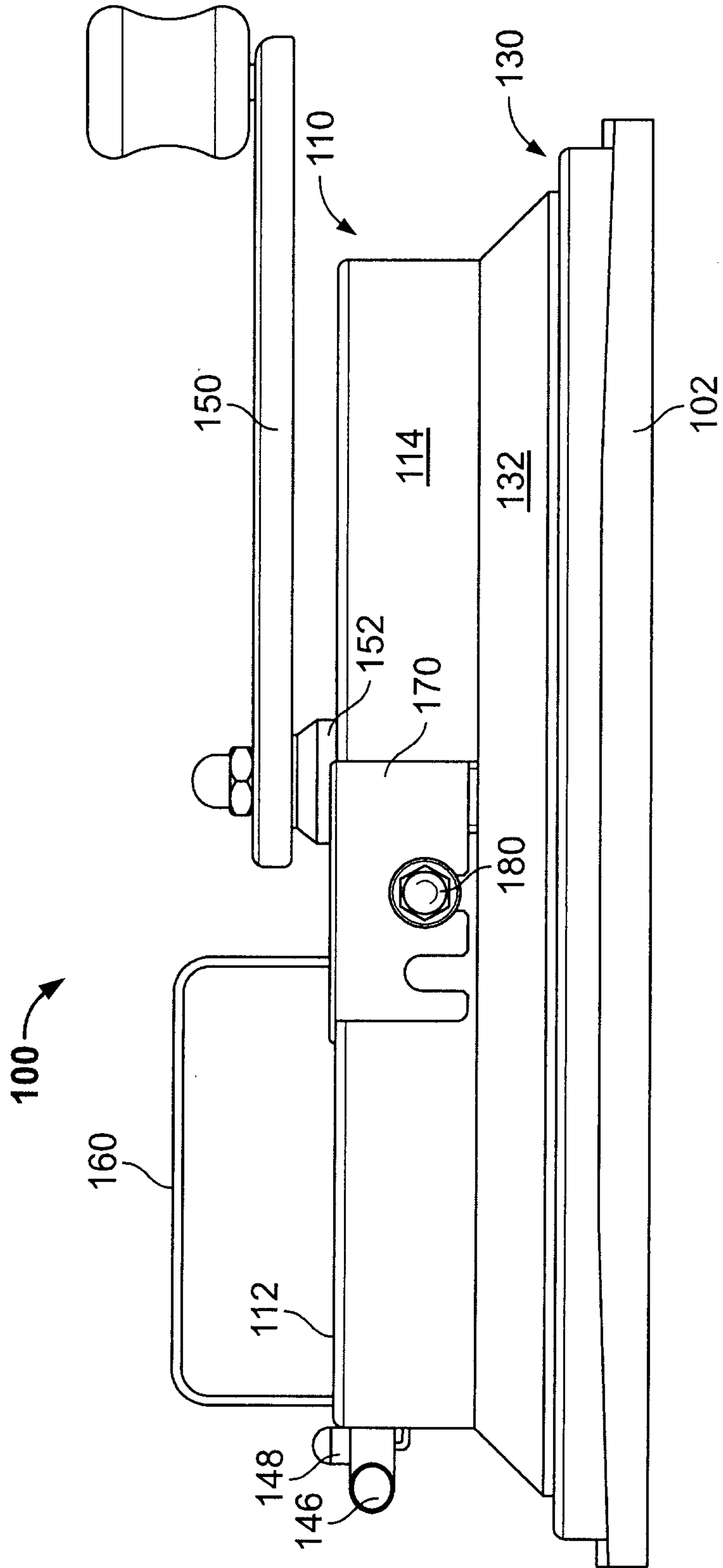

FIG. 5

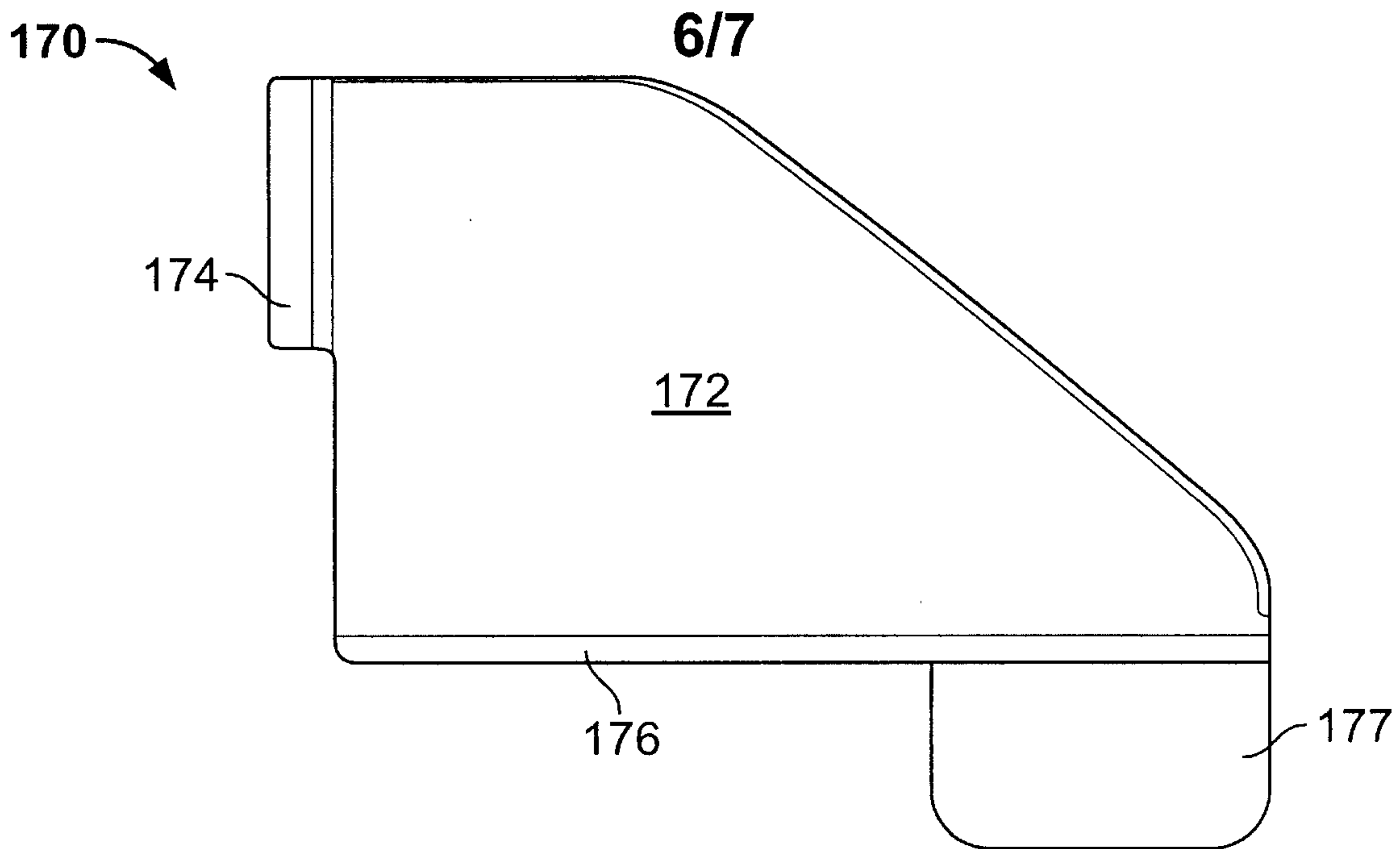

FIG. 6A

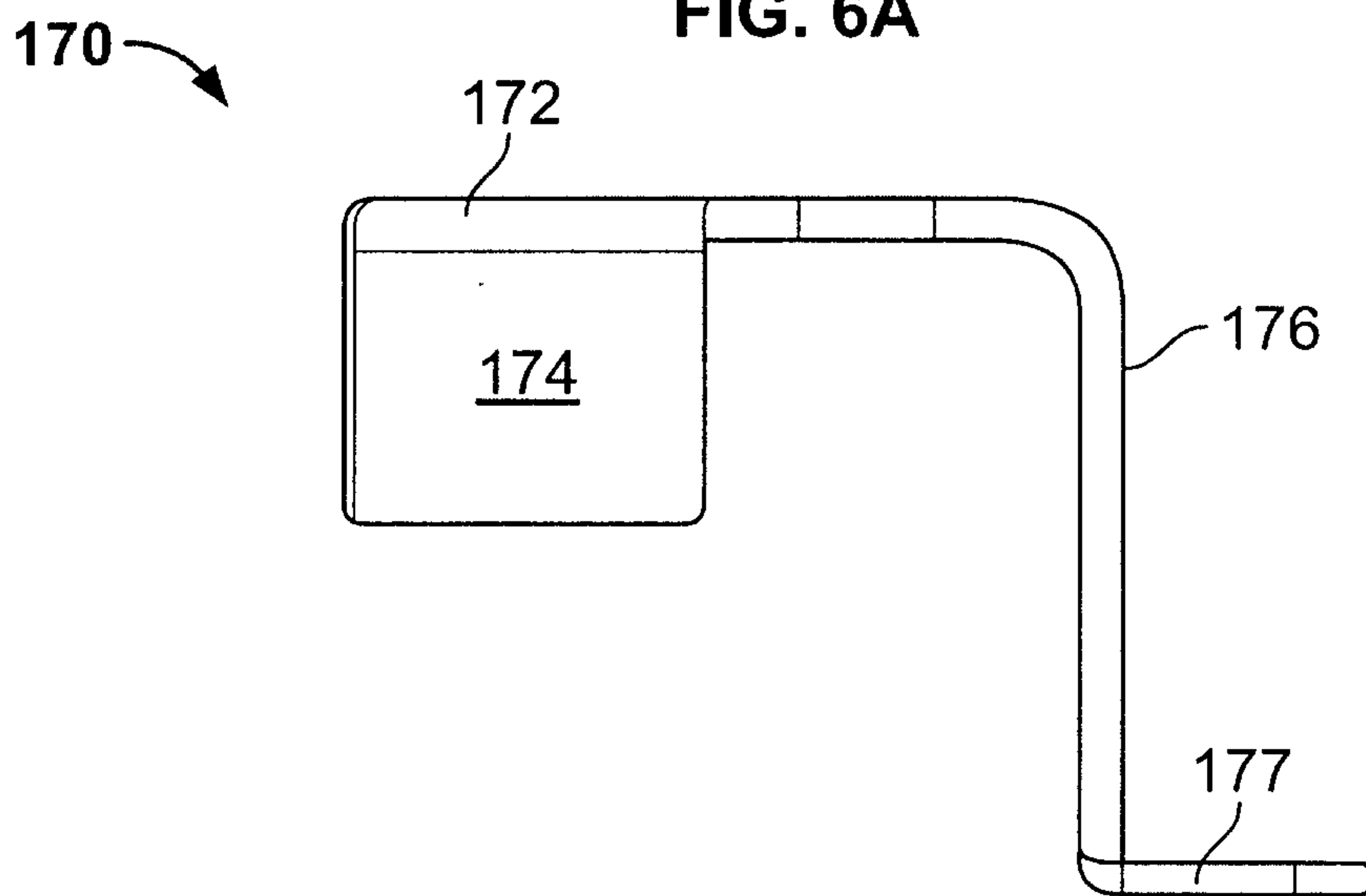

FIG. 6B

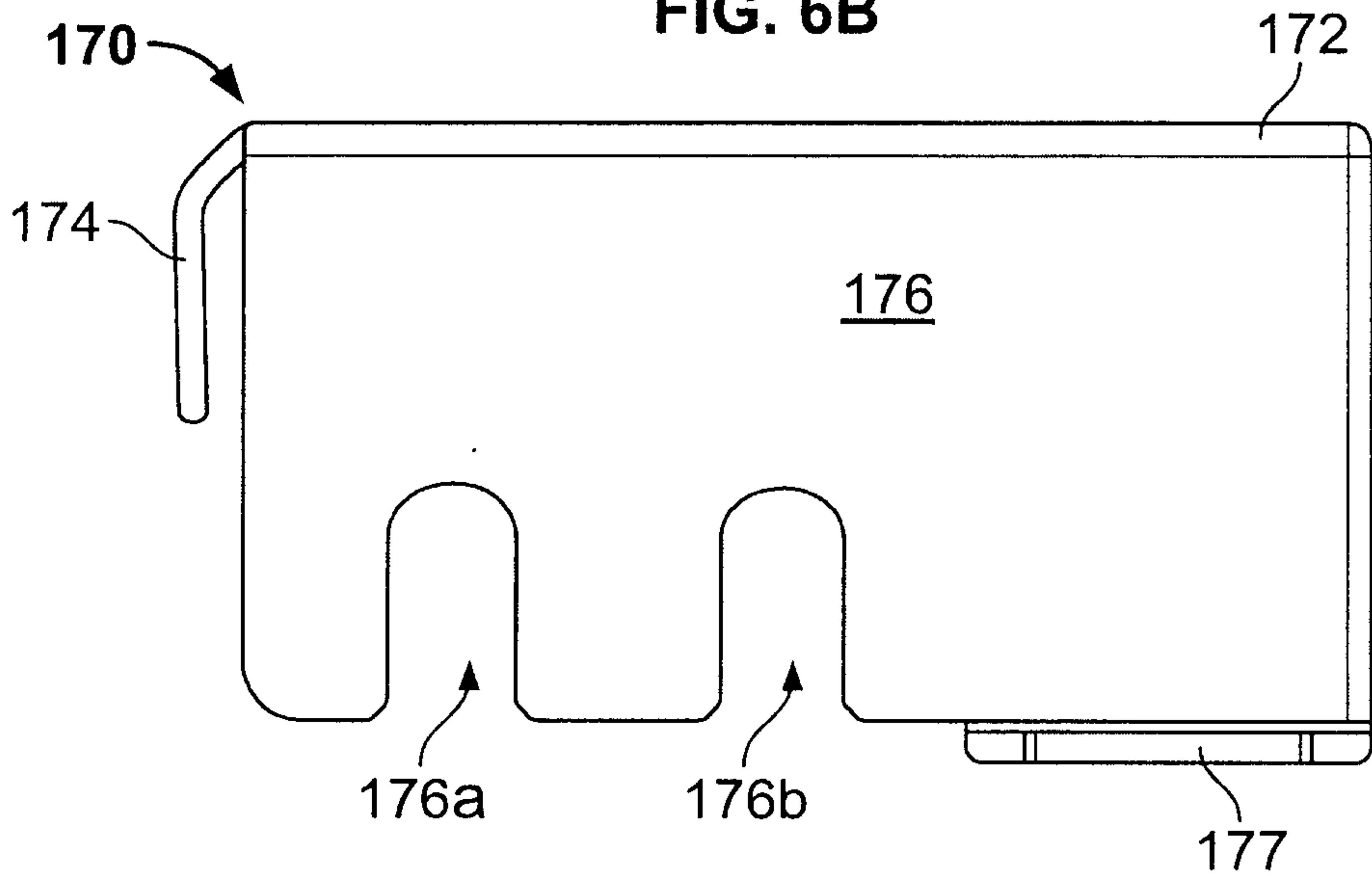

FIG. 6C

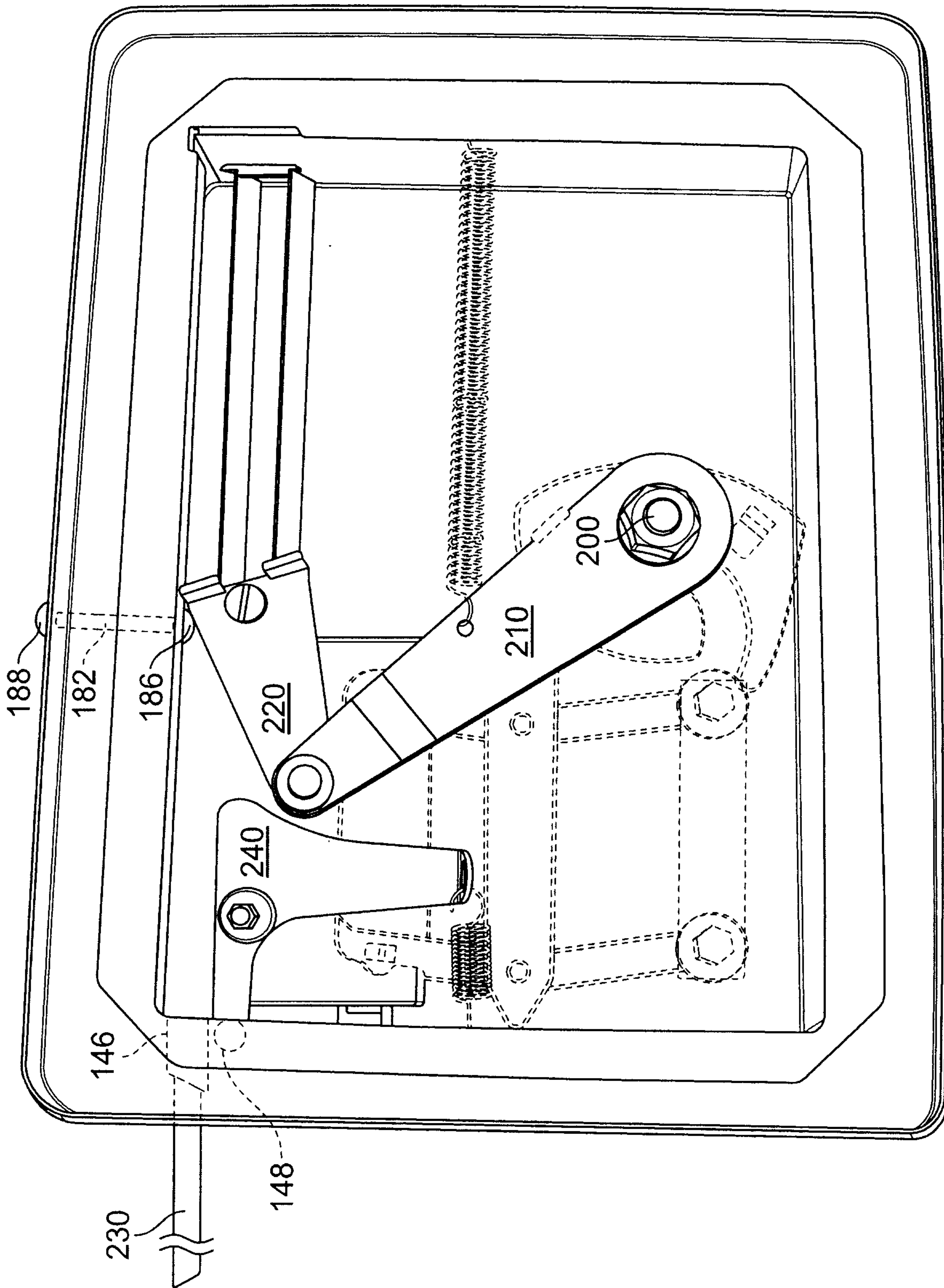

FIG. 7

