

No. 832,199.

PATENTED OCT. 2, 1906.

J. F. KACHLINE.
PRINTING MECHANISM.
APPLICATION FILED OCT. 23, 1905.

2 SHEETS—SHEET 1.

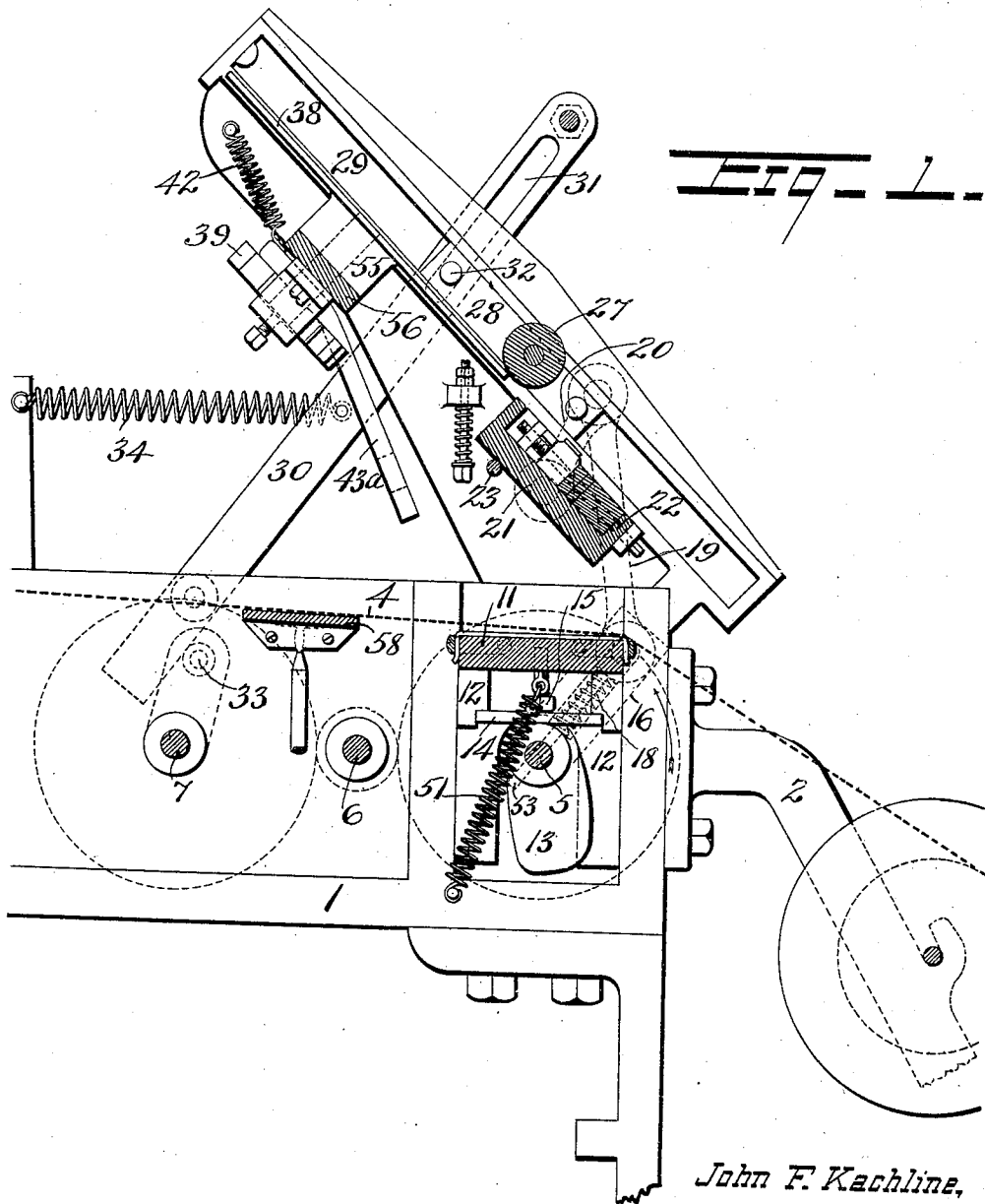

John F. Kachline,
Inventor

By *[Signature]*

Attorney

Witnesses
Henry H. Herman.
D. Stewart

J. F. KACHLINE.
PRINTING MECHANISM.
APPLICATION FILED OCT. 23, 1905.

Fig. 2.

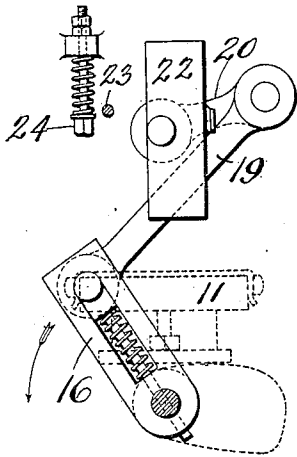

Fig. 3.

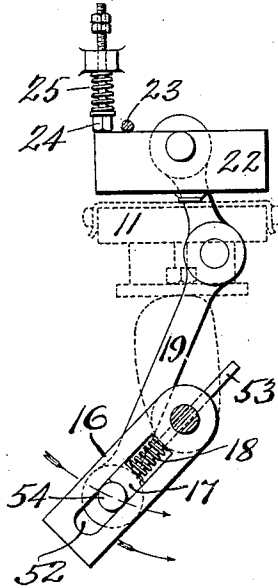

Fig. 4.

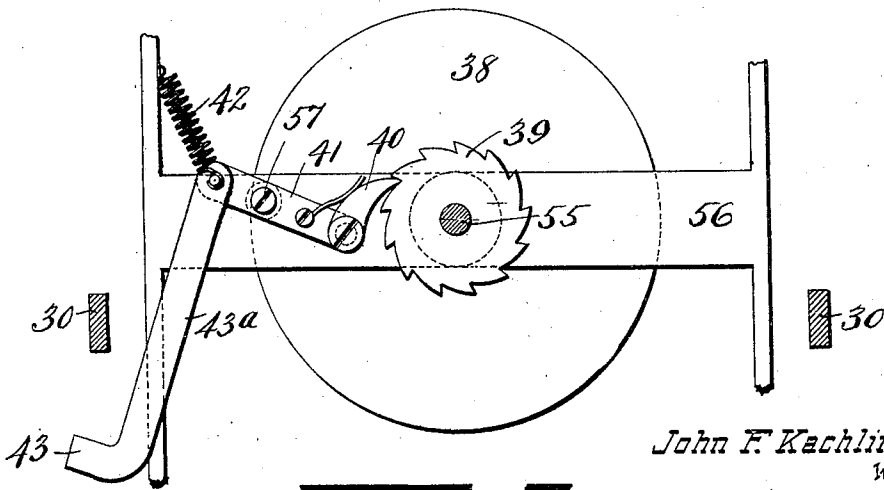
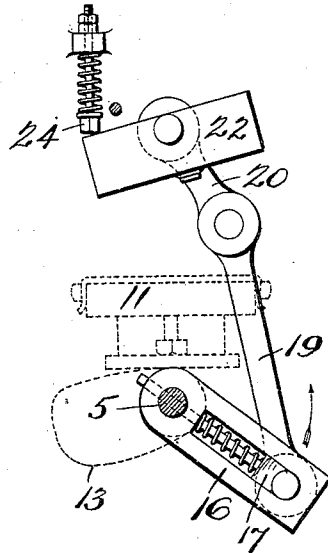

Fig. 5.

John F. Kachline.
Inventor

Attorney

Witnesses
Henry A. Herman,
T. M. Stewart

UNITED STATES PATENT OFFICE.

JOHN F. KACHLINE, OF READING, PENNSYLVANIA, ASSIGNOR OF ONE-HALF TO OSCAR B. WETHERHOLD, OF READING, PENNSYLVANIA.

PRINTING MECHANISM.

No. 832,199.

Specification of Letters Patent.

Patented Oct. 2, 1906.

Application filed October 23, 1905. Serial No. 283,920.

To all whom it may concern:

Be it known that I, JOHN F. KACHLINE, a citizen of the United States, and a resident of the city of Reading, county of Berks, and State of Pennsylvania, have invented certain new and useful Improvements in Printing Mechanism, of which the following is a specification.

My invention relates to printing mechanism adapted particularly for printing labels or the like and applicable to box-labeling machines such as shown in Patent No. 795,621, issued to me July 25, 1905, which illustrates my present mechanism as a part of such labeling-machine, though constituting a separate invention, which is now particularly described and claimed.

The drawings illustrate my improved printing mechanism applied in preferred form to the labeling-machine of my prior patent referred to, a portion only of which is indicated, Figure 1 being a partly-sectional side elevation of the rear or printing portion of said machine provided with my improved printing mechanism; Figs. 2, 3, and 4, diagrammatic views illustrating several positions of the pivotally-mounted printing-form and its reversing mechanism, and Fig. 5 a detail view of the mechanism for intermittently rotating the roller-inking disk.

In the drawings, 1 represents the frame of the machine, having at one end suitable hangers 2 for a paper-roll from which is drawn the strip to be printed and thereafter otherwise acted upon as required. In suitable bearings in the frame 1 are mounted transverse shafts 5, 6, and 7, provided with intermeshing gears, the pitch-circles of which are indicated by dotted lines. The strip of paper 4 passes over a printing-platen 11 and thence over any suitable feed-rolls and devices. (Not shown, as forming no part of the present invention.)

The platen 11, as shown, is secured to a slide 12, which is guided in suitable vertical slideways on the frame of the machine. The rising motion is imparted to said platen by means of a cam 13 on the shaft 5, acting upon a bottom plate 14 of the platen-slide 12, which plate is adjustable vertically in respect to the platen by means of screws 15, as indicated, whereby the position assumed by the platen 11 when at the limit of its upward movement can be readily regulated, while springs

51 serve to normally draw the platen downward. The upward movement of the platen is adapted to press the interposed paper strip 4 against the type-face of a printing-form 22 to make successive impressions upon the paper strip, which is moved forward a proper distance for each rotation of the cam-shaft 5.

The printing-form 22 is pivotally mounted in the frame of the machine on trunnions 21, as shown, so as to be capable of limited turning movements, whereby the type-face of the form is reversed in position from that indicated in Fig. 1 to that indicated in Fig. 3, and vice versa, so as to alternately cooperate with an inking-roller 27 and with the printing-platen 11. The mechanism for effecting this reversal of the printing-form 22 comprises a crank-arm or cam 16 on the shaft 5 with a yieldingly-connected link 19 extending therefrom to an arm 20 of the printing-form, whereby each complete rotation of said crank 16 causes partial rotation of said printing-form in opposite directions to different extreme positions determined by a suitably-located stop 23, against which it is temporarily held during the passage of the crank-arm 16 over the respective dead-centers of its orbit. To attain this result, said crank-arm 16 is provided, as shown, with a radial slot 52, in which is slidably mounted a bearing-plate 17, having a guide-stem 53, provided with a spring 18, arranged to yieldingly press said bearing-plate radially outward, and the lower end of the link 19 is provided with a bearing-arm 54, which is engaged in said slot 52 between the yoked end of the crank-arm 16 and the sliding bearing-plate 17 therein, so that the rotating action of the crank-arm 16 upon the printing-form 22 is exerted through this yielding-link connection. The stop-bar 23, as shown, serves as a fixed stop to the reversing movement of the printing-frame in either direction; but in connection therewith I preferably provide a yielding pusher-rod 24, acted on by a spring 25, against which the printing-form strikes before it is fully inverted for the action of the platen and which serves by its recoil to carry the link connection over the dead-center, so that the crank-arm 16 can more effectually operate in reversing the printing-frame to inking position.

The inking operation is effected by the roller 27, which is mounted at each end in a slide 28, suitably guided in an inclined slotted

portion 29 of the fixed frame, motion being imparted to said slide by means of a lever 30, slotted, as at 31, for the reception of a pin 32 on the slide, vibrating movement being imparted to said lever by means of a crank-pin 33 on the shaft 7 operating against a spring 34, arranged to effect the return movement of the slide and roller. During the upper portion of its travel the roller 27 is in contact with an inking-disk 38, which has a central spindle 55, mounted in a suitable bearing-plate 56 on the frame of the machine and provided with a ratchet-wheel 39, which is engaged by a pawl 40 (see Fig. 5) on a lever 41, pivoted to the frame at 57. This pawl-lever 41 is moved in one direction by a spring 42 and in the opposite direction by contact of the lever 30 with a lug 43 on a link 43^a, which is pivoted to the lever 41, so that a partial turning movement of the disk 38 is effected during the travel of the roller 27 over the printing-frame.

The operation of my improved printing mechanism will be clearly understood from the foregoing description in connection with the diagrammatic views, Figs. 2, 3, and 4, illustrating successive positions of the printing-form and its reversing mechanism. In Fig. 1 the form has just been moved to inking position, where it is held against the stop-bar 23, while the crank-arm 16 is being swung in the direction indicated by the arrow over the upper dead-center of its orbit, during which movement the bearing-plate 17 is slid radially inward on the crank-arm 16 against its spring 18, while the stationary form is inked by the downward movement of the roller 27. In Fig. 2 the crank-arm has been swung past its upper dead-center and the printing-form 40 has begun its reversing movement toward the platen 11. In Fig. 3 the printing-form is shown fully reversed ready for the printing action, which latter is effected by the rising movement of the platen 11, while the form is stationary, the crank-arm 16 during this action being swung over the lower dead-center to the position indicated in Fig. 4, as permitted by the yielding-link connection. When

in the latter position, the platen has been lowered and the upward reversing movement of the form 22 begun, the action of the pusher-rod 24 thereon having insured the turning of the arm 20 and the link 19 out of line, so that the crank-arm 16 can act to continue the reversing movement. Meanwhile the inking-disk 38 has been partially rotated, and the inked roller 27 is ready to repeat its downward movement over the printing-form when the latter is returned to the original position indicated in Fig. 1. The paper strip 4 after being printed is carried forward over a suitable drier-plate 58, located forward the lowered plate 11.

The particular construction thus specifically described may obviously be modified without departing from the spirit of my invention as pointed out in the claims.

What I claim is—

1. The combination with the vertically-reciprocating platen and the transversely-reciprocating inking-roller above the same, of the intermediate pivotally-mounted printing-form having a crank-arm, a rotary shaft below said platen having a platen-operating cam and a form-reversing crank, a connecting-link between said cranks having a spring-backed slidable bearing-block, and stops for said form whereby the same is temporarily held in reversed positions for inking and printing respectively, substantially as set forth.

2. The combination with the inking mechanism and movable platen, of the pivotally-mounted printing-form having a limited reversing movement, a reversing mechanism for said form comprising a rotating crank and link connection thereto, and a yielding pusher against which the rotating form bears as it approaches position for the action of the platen substantially as set forth.

In testimony whereof I affix my signature in the presence of two witnesses.

JOHN F. KACHLINE.

Witnesses:

HENRY H. HERMAN,
D. M. STEWART.