

Feb. 9, 1932.

W. HOLOFF

1,844,578

SANITARY TOILET

Filed Feb. 3, 1931

3 Sheets-Sheet 1

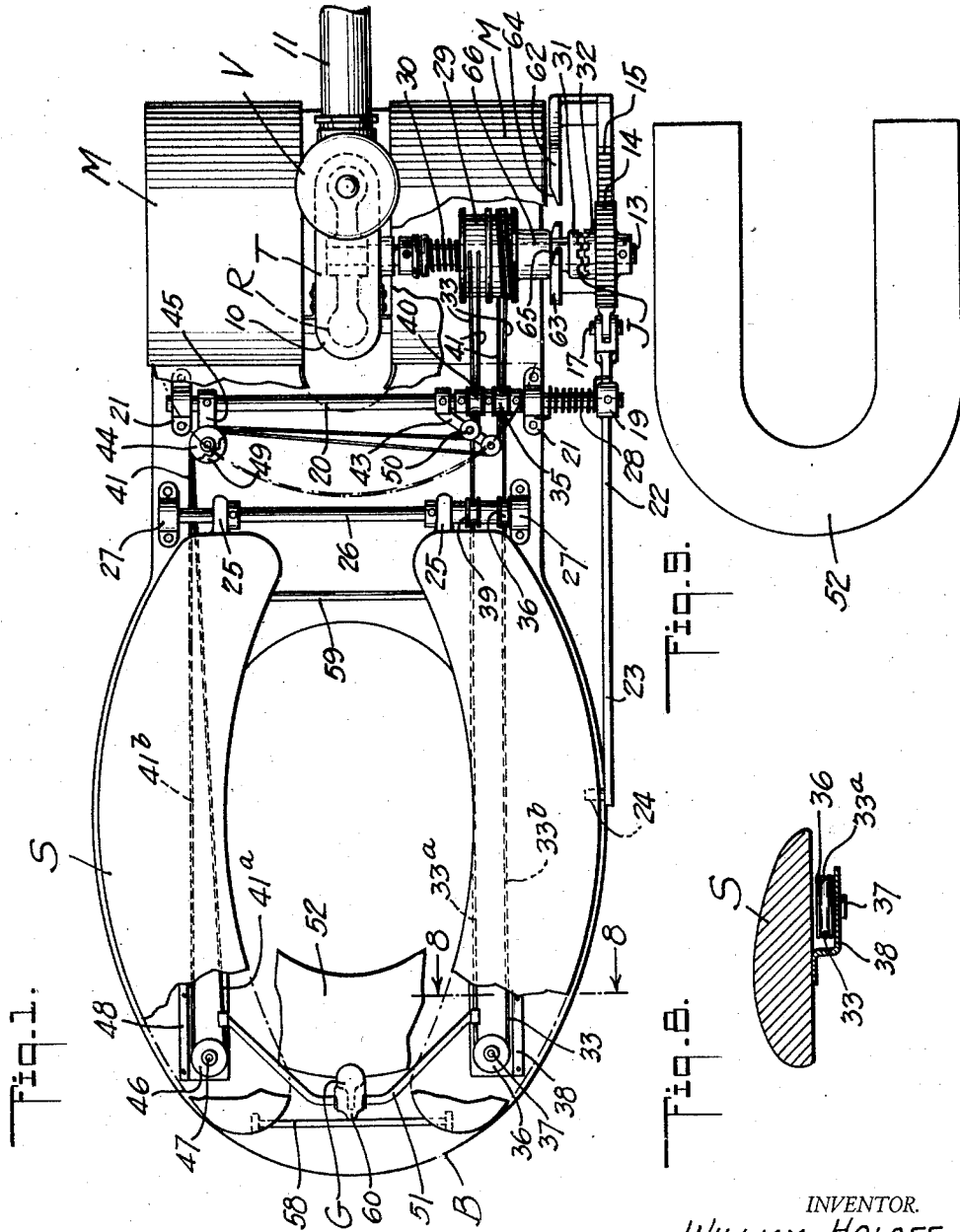

INVENTOR.  
WILLIAM HOLOFF  
BY *Wm. H. [Signature]*  
ATTORNEYS.

Feb. 9, 1932.

W. HOLOFF

1,844,578

SANITARY TOILET

Filed Feb. 3, 1931

3 Sheets-Sheet 2

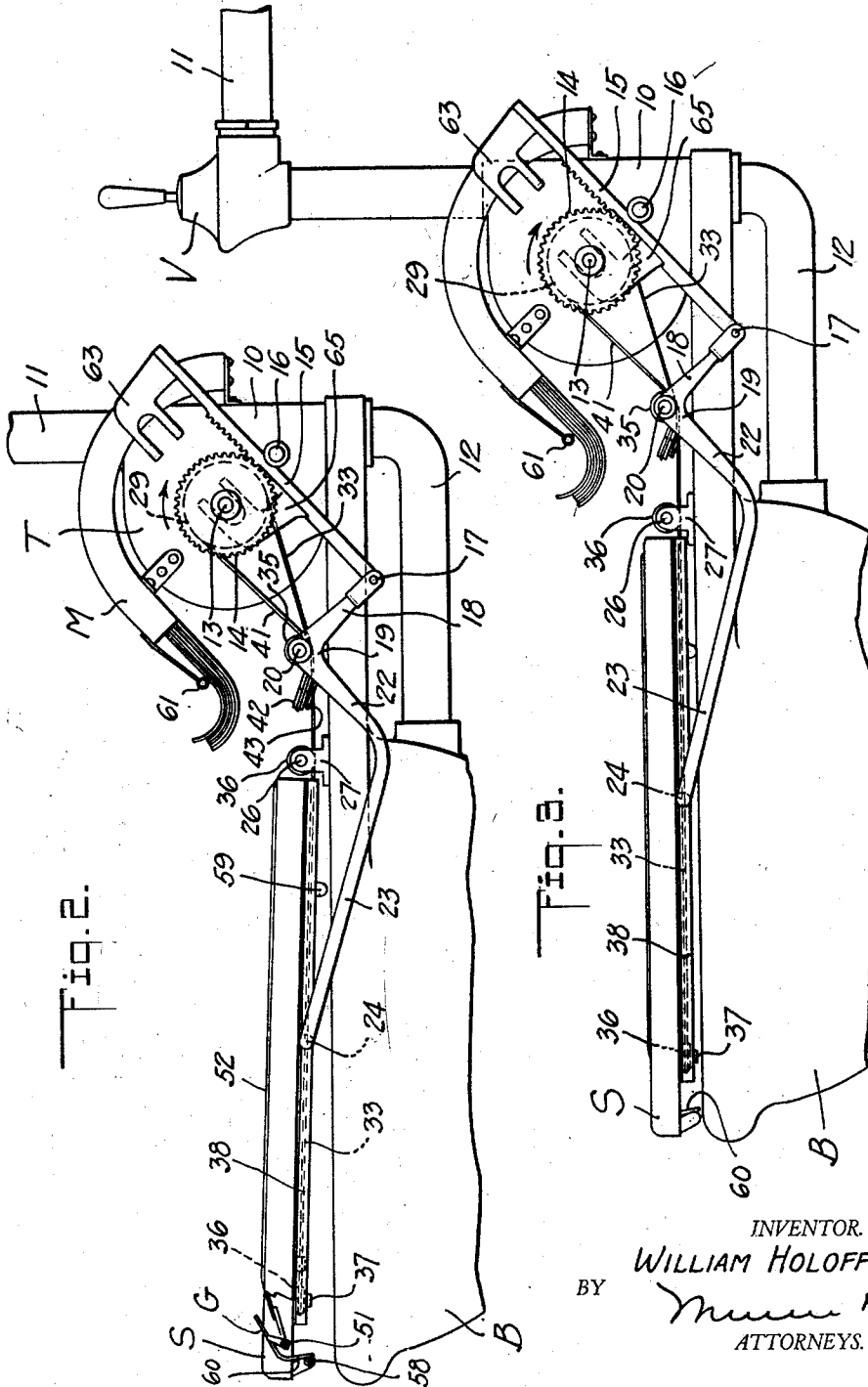

INVENTOR.  
WILLIAM HOLOFF  
BY *Wm. H. Co.*  
ATTORNEYS.

Feb. 9, 1932.

W. HOLOFF

1,844,578

SANITARY TOILET

Filed Feb. 3, 1931

3 Sheets-Sheet 3

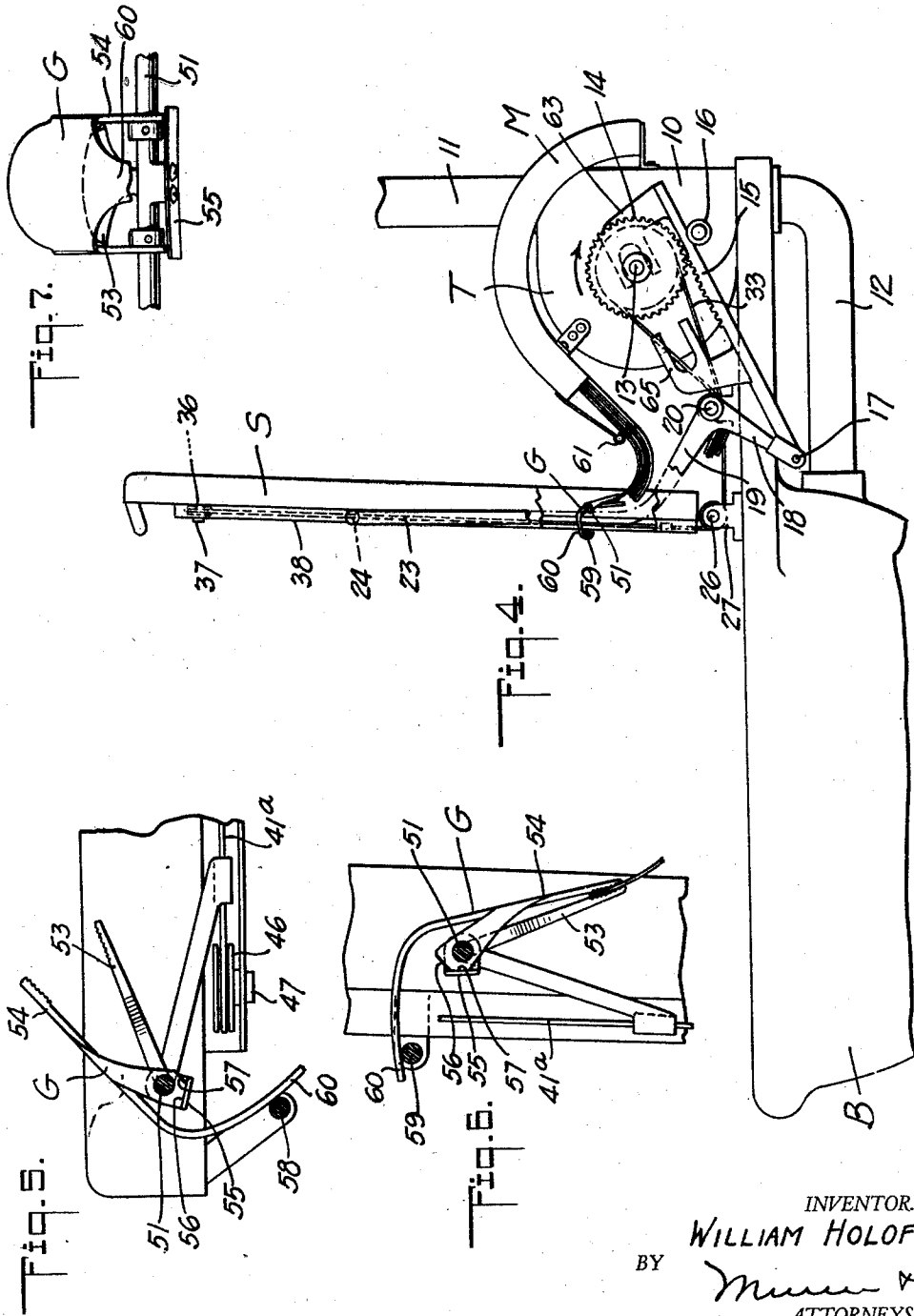

INVENTOR.  
WILLIAM HOLOFF  
BY *Wm. H. Co.*  
ATTORNEYS.

# UNITED STATES PATENT OFFICE

WILLIAM HOLOFF, OF LOS ANGELES, CALIFORNIA

## SANITARY TOILET

Application filed February 3, 1931. Serial No. 513,222.

My invention relates to and has for its purpose the provision of a toilet embodying mechanism by which a sanitary cover sheet can be withdrawn from a magazine and spread upon the seat of the toilet so that in the event the seat is not in a sanitary condition, the cover sheet will provide adequate protection for the user of the toilet against contamination from the seat.

It is a further purpose of my invention to provide a sanitary toilet, the mechanism of which is hydraulically operated and is responsive to flushing of the toilet bowl, to raise the seat from the bowl and to grip a cover sheet in the magazine for withdrawal of the sheet from the magazine automatically by the mechanism upon lowering of the seat manually.

I will describe only one form of sanitary toilet embodying my invention, and will then point out the novel features thereof in claims.

In the accompanying drawings:

Figure 1 is a view showing in plan one form of sanitary toilet embodying my invention.

Figure 2 is a view of the toilet in side elevation with the toilet seat shown in a lowered position for use.

Figures 3 and 4 are views similar to Figure 2 and illustrating different positions of the toilet seat.

Figures 5 and 6 are enlarged detail views showing in side elevation and in open and closed positions respectively, a sheet gripping device embodied in my invention.

Figure 7 is a view of the sheet gripping device in front elevation.

Figure 8 is an enlarged sectional view taken on the line 8—8 of Figure 1, and

Figure 9 is a plan view of a sanitary cover sheet which is applied to the toilet seat by the mechanism embodied in my invention.

Referring specifically to the drawings in which similar reference characters designate similar parts in each of the several views, my invention in its present embodiment comprises a turbine T of conventional design, the casing 10 of which has an inlet connected to a pipe 11 leading from a source of water supply and embodying a conventional flush valve V of the automatic type. The outlet 12 of the

casing is connected to the bowl B of a toilet, and journaled in the casing is a rotor R (Figure 1) which is driven in the direction of the arrows in Figures 2, 3, and 4 by water from the source of supply when the valve V is opened to flush the bowl.

The shaft 13 of the turbine to which the rotor is fixed, extends from the casing and has secured thereto so as to be driven thereby a gear 14 meshing with a rack bar 15 supported by a guide roller 16 to maintain its teeth in meshing relation with the teeth of the gear.

To one end of the rack bar is pivotally connected at 17 one arm 18 of a bell crank lever 19 fixed to a rock shaft 20 mounted in bearings 21 secured on the rearward extension of the bowl B as is the turbine T. The other arm 22 of the bell crank lever is provided with an angular extension 23 having a pin 24 engaging beneath a side edge of the toilet seat S which latter is constructed in two sections provided with ears 25 hinged on a rod 26 secured in brackets 27 on the rearward extension of the bowl, to the end that when the seat S is unoccupied as in Figure 2, the gear 14 will co-act with the rack bar 15 to swing the seat upwardly from the position shown in this figure to the position shown in Figure 4.

When the seat reaches the raised position shown in Figure 4, the teeth of the gear disengage those of the rack bar so that continued rotation of the rotor by the flushing water will be ineffective to further move the rack bar, thus limiting the raised position of the seat. When the seat is occupied as in Figure 3, the gear 14 is also out of mesh with the teeth of the rack bar so that should the toilet be flushed, rotation of the gear by the rotor will also be ineffective to move the rack bar and raise the seat.

In order to bring the teeth of the rack bar into engagement with those of the gear when the seat is unoccupied so that flushing of the toilet will raise the seat, a coil spring 28 is mounted on the rod 26 and has one end secured to the bell crank lever 19 and its other end to one of the brackets 27 so as to move the rack bar a sufficient amount for the first tooth

at one end of the series of teeth on the rack bar to be brought into mesh with the gear as shown in Figure 2, which movement slightly elevates the seat as shown in this figure, to the end that when the gear 14 is driven by the rotor, the seat will be swung upwardly to the raised position previously described.

Rotatably mounted on the shaft 13 is a drum 29 normally urged longitudinally on the shaft to one extreme position by a spring 30, for the purpose of operatively connecting the drum to the gear 14 for rotation by the latter, and to this end I provide a jaw clutch J one member 31 of which is fixed to the drum and the other member 32 to the gear. Under the normal urging action of the spring 30 the teeth of the clutch members are engaged so that the drum will be driven by and in the same direction as the gear.

Secured to the drum 29 is one end of a cable 33 which extends forwardly beneath the shaft 20 and rod 26 so as to ride on idler pulleys 34 and 35 on the shaft and rod. The cable 33 is trained about a pulley 36 rotatably mounted at 37 adjacent the forward end of the seat S, on a bar 38 secured to the bottom of the seat S, and the cable then extends rearwardly of the seat underneath the rod 26 and shaft 20 to ride on other idler pulleys 39 and 40, with its other end secured to the drum.

A second cable 41 is secured to the drum and is trained about an idler pulley 42 mounted on an arm 43 fixed to the rock shaft 20. The cable 41 then extends transversely of the seat and is trained about a second idler pulley 44 mounted on a second arm 45 also secured to the rock shaft. From the pulley 44, the cable 41 extends forwardly beneath the seat S and is trained about a pulley 46 rotatably mounted at 47 adjacent the forward end of the seat but on the opposite side of the seat opening to the cable 33, on a bar 48 also secured to the bottom of the seat.

The cable 41 then extends rearwardly beneath the seat and is trained about a second idler pulley 49 on the arm 45 from which the cable extends transversely of the seat and is trained about a second idler pulley 50 on the arm 43 from which the cable extends rearwardly and is secured to the drum 29.

The cables 33 and 41 thus provide two inner stretches 33<sup>a</sup> and 41<sup>a</sup> extending forwardly and rearwardly of the seat at opposite sides of the seat opening, and adapted to simultaneously travel forwardly or rearwardly of the seat according as the drum 29 is driven in one direction or the other by the gear 14.

When the drum is driven in the direction of the arrows in Figures 2, 3, and 4, the inner stretches 33<sup>a</sup> and 41<sup>a</sup> of the respective cables will travel rearwardly of the seat due to the fact by the arrangement of pulleys above described, the inner stretches will be caused to wind upon the drum, whereas the outer

stretches 33<sup>b</sup> and 41<sup>b</sup> of the respective cables will be caused to unwind from the drum.

Secured to and supported by the inner stretches of the cables so as to span the seat opening, is a bar 51 which constitutes a support for a gripping element G by means of which a sanitary sheet 52 of suitable paper or other material is adapted to be withdrawn from a magazine M to cover the seat S of the toilet and thus protect the user of the toilet against contamination should the seat not be in a sanitary condition.

The gripping element G comprises two jaws 53 and 54, the former of which is fixed to the bar 51, and the latter pivoted on the bar 51 to occupy either the open or closed position relative to the fixed jaw 53 as shown respectively in Figures 5 and 6. The movable jaw 54 is releasably retained in either position by a flat spring 55 which is adapted to bear against either of two flat sides 56 and 57 formed on the hub portion of the movable jaw as shown in Figures 5 and 6.

It will be clear that the gripping element will be caused to move forwardly or rearwardly along the longitudinal axis of the seat S according as the inner stretches 33<sup>a</sup> and 41<sup>a</sup> of the respective cables 33 and 41 are correspondingly moved, and in order to open or close the gripping element according as the latter reaches an extreme forward or rearward position relative to the seat, trip bars 58 and 59 span the seat transversely and are secured underneath the seat adjacent its forward and rear ends respectively. The trip bars are disposed in the path of movement of an extension 60 forward on the movable jaw 54 of the gripping element, to the end that when the gripping element approaches its forward extreme position, the extension 60 will strike the trip bar 58 and open the gripping element, whereas when the latter approaches its rearward extreme position the extension 60 will strike the trip bar 59 and close the gripping element.

The sanitary cover sheet 52 is of U-shape in plan as shown in Figure 9, and a number of these sheets are supported in the magazine M in stack formation with the closed ends of the sheets disposed forwardly and frictionally retained in the magazine by a spring pressed roller 61 which normally bears upon the closed end of the uppermost sheet, the forward edge of which projects in advance of the remaining sheets and is positioned to enter between the open jaws of the gripping element G when the latter approaches its rearmost extreme position as occurs as the seat approaches its raised position shown in Figure 4.

In order to limit the movement of the gripping element G to the forward and rearward extreme positions shown in Figures 2 and 4 respectively, the rack bar 15 is provided with clutch throwout members 62 and 63 in the

form of yokes the arms of which have bevel surfaces 64 and 65 respectively which are adapted to engage a collar 66 formed on the drum 29, to shift the latter along the shaft 13 against the action of the spring 30 and disengage the member 31 of the clutch J from the member 32 according as the rack bar reaches either the extreme position shown in Figure 3 or the other extreme position shown in Figure 4, to the end of preventing the drum 29 from being driven by the gear 14.

The operation of the mechanism above described is as follows:

Let it be assumed that the seat S occupies the raised position shown in Figure 4, wherein the gripping element G occupies its closed position and is gripping the uppermost sheet 52 in the magazine M. Upon lowering the seat manually, the bell crank lever 19 will be rocked and will move the rack bar 15 to bring the teeth of the latter into mesh with those of the gear and cause the latter to be rotated in a direction reverse to that of the arrow shown in this figure. As the clutch throw-out member 62 disengages the collar 66 during this initial movement of the rack bar, the drum 29 will be driven to cause the inner stretches 33<sup>a</sup> and 41<sup>a</sup> of the respective cables 33 and 41 to move forwardly of the seat S and hence correspondingly move the gripping element to withdraw the uppermost sheet from the magazine upon the seat so that the sheet covers the latter. During the initial withdrawing movement of the uppermost sheet from the magazine, the sheet immediately beneath the uppermost sheet will by the friction between itself and the uppermost sheet, be slightly withdrawn with the latter so that its forward edge projects in advance of the remaining sheets.

This feeding of the second sheet continues until the roller 61 rides off the closed end of the uppermost sheet onto the second sheet when forward movement of the latter is arrested, so that the second sheet will be disposed with its forward edge in advance of the remaining sheets for gripping by the gripping element G when the seat S is again moved to its raised position shown in Figure 4. As the seat approaches its lowered position shown in Figure 2, the extension 60 of the movable jaw 54 of the gripping element strikes the trip bar 58 and moves the jaw to open position thus releasing the sheet 52 after which the clutch throw-out member 63 engages the collar 66 to disconnect the drum 29 from the gear 14 and prevent further forward movement of the gripping element.

With the seat unoccupied and upon flushing the toilet after the used cover sheet has been deposited in the bowl of the toilet, the gear 14 will be driven by the rotor R in the direction of the arrow in Figure 2, thus causing the seat to be moved to its raised position shown in Figure 4 and initially disen-

gaging the clutch throw-out member 63 from the collar 66 so that the drum 29 will be driven by the gear 14 and hence move the gripping element to its rearmost extreme position. As the seat approaches its raised position, the extension 60 of the gripping element will strike the trip bar 59 to move the jaw 54 of the gripping element to closed position and thus grip the uppermost sheet in the magazine for withdrawal therefrom upon lowering the seat manually as previously described.

After the gripping element has closed, the clutch throw-out member 62 engages the collar 66 to again disconnect the drum from the gear 14 so that further rearward movement of the gripping element will be discontinued, and when the seat reaches its fully raised position shown in Figure 4 the gear 14 disengages the teeth of the rack bar 15 so that flushing of the toilet bowl can continue without transmitting the rotational movement of the gear to the rack bar. In the event that the bowl is flushed while the seat is occupied, the motion of the gear 14 will not be transmitted to the rack bar as the gear is free from the teeth of the latter, nor will the gripping element move rearwardly as the clutch J has disconnected the drum 29 from the gear.

Although I have herein shown and described only one form of sanitary toilet embodying my invention, it is to be understood that various changes and modifications may be made therein without departing from the spirit of the invention and the spirit and scope of the appended claims.

I claim:

1. A sanitary toilet comprising mechanism for raising the seat of the toilet from the toilet bowl in response to flushing of the latter, a sheet containing magazine, a gripping element having relatively movable jaws, means for mounting the gripping element for movement forwardly and rearwardly of the toilet seat, means for actuating the mounting means to move the gripping element rearwardly or forwardly of the toilet seat according as the seat is raised or lowered, means for closing the jaws of the gripping element upon a sheet in the magazine when the seat is raised, for withdrawal of the sheet from the magazine and spreading of the sheet on the toilet seat when the latter is lowered, and means for opening the jaws to release the sheet when the toilet seat has been lowered.

2. A sanitary toilet comprising mechanism for raising the seat of the toilet from the toilet bowl in response to flushing of the latter, a sheet containing magazine, a gripping element having relatively movable jaws, cable and pulley means for mounting the gripping element for movement forwardly and rearwardly of the toilet seat, means for actuating the cables to move the

gripping element rearwardly or forwardly of the toilet seat according as the seat is raised or lowered, a trip member on the toilet seat engageable by the gripping element to close the jaws of the latter upon a sheet in the magazine when the seat is raised, for withdrawal of the sheet from the magazine and spreading of the sheet on the toilet seat when the latter is lowered, and a second trip member on the seat engageable by the gripping element to open the jaws of the latter and release the sheet when the toilet seat has been lowered.

3. A sanitary toilet comprising a turbine having a rotor mounted for rotation by the flushing water in response to flushing of the toilet bowl, a shaft to which the rotor is fixed, a gear fixed to the shaft, a rack bar in mesh with the gear, means for operatively connecting the rack bar to the toilet seat to raise the latter in response to rotation of the gear by the rotor, a gripping element, means for mounting the gripping element for movement forwardly and rearwardly of the toilet seat, means for actuating the mounting means to move the gripping element rearwardly or forwardly of the toilet seat according as the latter is raised or lowered, a sheet containing magazine, and means for causing the gripping element to grip a sheet in the magazine when the seat is raised for withdrawal of the sheet from the magazine and spreading of the sheet on the toilet seat when the latter is lowered.

4. A sanitary toilet comprising a turbine having a rotor mounted for rotation by the flushing water in response to flushing of the toilet bowl, a shaft to which the rotor is fixed, a gear fixed to the shaft, a rack bar in mesh with the gear, means for operatively connecting the rack bar to the toilet seat to raise the latter in response to rotation of the gear by the rotor, a drum rotatably mounted on the shaft, a clutch for operatively connecting the drum to the shaft, cables secured to the drum, pulleys mounted on the seat adjacent its forward end and about which the cables are trained, a gripping element connected to the cables to travel therewith rearwardly or forwardly of the toilet seat in response to rotation of the drum in one direction or the other, and according as the seat is raised or lowered, a sheet containing magazine, means for causing the gripping element to grip a sheet in the magazine when the seat is raised, for withdrawal of the sheet from the magazine and spreading of the sheet on the toilet seat when the latter is lowered, and means for actuating the clutch to disconnect the drum from the shaft when the gripping element has been moved to predetermined forward and rearward positions relative to the seat.

5. A sanitary toilet comprising a turbine having a rotor mounted for rotation by the flushing water in response to flushing of the

toilet bowl, a shaft to which the rotor is fixed, a gear fixed to the shaft, a rack bar in mesh with the gear, means for operatively connecting the rack bar to the toilet seat to raise the latter in response to rotation of the gear by the rotor, a drum rotatably mounted on the shaft, a clutch for operatively connecting the drum to the shaft, cables secured to the drum, pulleys mounted on the seat adjacent its forward end and about which the cables are trained, a gripping element connected to the cables to travel therewith rearwardly or forwardly of the toilet seat in response to rotation of the drum in one direction or the other, and according as the seat is raised or lowered, a sheet containing magazine, means for causing the gripping element to grip a sheet in the magazine when the seat is raised, for withdrawal of the sheet from the magazine and spreading of the sheet on the toilet seat when the latter is lowered, and clutch throw-out members on the rack bar for actuating the clutch to disconnect the drum from the shaft when the gripping element has been moved to predetermined forward and rearward positions relative to the seat.

6. A sanitary toilet comprising a turbine having a rotor mounted for rotation by the flushing water in response to flushing of the toilet bowl, a shaft to which the rotor is fixed, a gear fixed to the shaft, a rack bar in mesh with the gear, a second shaft, a bell crank lever mounted on the second shaft and having one arm connected to the rack bar and its other arm engaging the toilet seat to raise the latter in response to rotation of the first shaft by the rotor, a gripping element, means for mounting the gripping element for movement forwardly and rearwardly of the toilet seat, means for actuating the mounting means to move the gripping element rearwardly or forwardly of the toilet seat according as the latter is raised or lowered, a sheet containing magazine, and means for causing the gripping element to grip a sheet in the magazine when the seat is raised, for withdrawal of the sheet from the magazine and spreading of the sheet on the toilet seat when the latter is lowered.

7. A sanitary toilet having a seat mounted for movement to occupy lowered and raised positions with respect to the toilet bowl, and hydraulically operated means for moving the seat to its raised position in response to flushing of the toilet bowl.

8. A sanitary toilet having a seat mounted for movement to occupy lowered and raised positions with respect to the toilet bowl, a turbine having a rotor mounted for rotation by the flushing water in response to flushing of the toilet bowl, and means for operatively connecting the rotor to the seat to raise the latter in response to rotation of the rotor.

9. A sanitary toilet having a seat mount-

ed for movement to occupy lowered and raised positions with respect to the toilet bowl, a sheet containing magazine, a gripping element, means for mounting the gripping element on the seat for movement forwardly and rearwardly of the seat, means for actuating the mounting means to move the gripping element rearwardly or forwardly of the seat according as the latter is raised or lowered, and means for actuating the gripping element to grip a sheet in the magazine when the seat is raised and the gripping element reaches a predetermined position, for withdrawal of the sheet from the magazine by the gripping element and spreading of the sheet over the seat when the latter is moved to lowered position.

10. A sanitary toilet having a seat mounted for movement to occupy lowered and raised positions with respect to the toilet bowl, a sheet containing magazine, a gripping element, means for mounting the gripping element on the seat for movement forwardly and rearwardly of the seat, means for actuating the mounting means to move the gripping element rearwardly or forwardly of the seat according as the latter is raised or lowered, means for actuating the gripping element to grip a sheet in the magazine when the seat is raised and the gripping element reaches a predetermined position, for withdrawal of the sheet from the magazine by the gripping element and spreading of the sheet over the seat when the latter is moved to lowered position, and means for actuating the gripping element to release the sheet when the latter has been spread over the toilet seat.

11. A sanitary toilet having a seat mounted for movement to occupy lowered and raised positions with respect to the toilet bowl, a turbine having a rotor mounted for rotation by the flushing water in response to flushing of the toilet bowl, means for operatively connecting the rotor to the seat to raise the latter in response to rotation of the rotor, a sheet containing magazine, a gripping element, means for mounting the gripping element on the seat for movement forwardly and rearwardly of the latter, means operable by the rotor in response to rotation of the latter, to actuate the mounting means and move the gripping element rearwardly as the seat is raised, and means for causing the gripping element to grip a sheet in the magazine when the element reaches a predetermined rearward position, for withdrawal of the sheet from the magazine and spreading of the sheet on the seat as the latter is lowered.

12. A sanitary toilet having a seat mounted for movement to occupy lowered and raised positions with respect to the toilet bowl, a turbine having a rotor mounted for rotation by the flushing water in response to flushing of the toilet bowl, means for operatively connecting the rotor to the seat to raise the latter

in response to rotation of the rotor, a sheet containing magazine, a gripping element, means for mounting the gripping element on the seat for movement forwardly and rearwardly of the latter, means operable by the rotor in response to rotation of the latter, to actuate the mounting means and move the gripping element rearwardly as the seat is raised, means for causing the gripping element to grip a sheet in the magazine when the element reaches a predetermined rearward position, for withdrawal of the sheet from the magazine and spreading of the sheet on the seat as the latter is lowered, and means for releasing the gripping element from the sheet when spread on the seat.

WILLIAM HOLOFF.

70

75

80

85

90

95

100

105

110

115

120

125

130