

(19) World Intellectual Property Organization  
International Bureau



(43) International Publication Date  
8 November 2007 (08.11.2007)

PCT

(10) International Publication Number  
**WO 2007/126830 A2**

- (51) International Patent Classification:  
*G11C 16/04* (2006.01)
- (21) International Application Number:  
PCT/US2007/007591
- (22) International Filing Date: 29 March 2007 (29.03.2007)
- (25) Filing Language: English
- (26) Publication Language: English
- (30) Priority Data:  
60/790,111 7 April 2006 (07.04.2006) US  
11/724,552 15 March 2007 (15.03.2007) US
- (71) Applicant (for all designated States except US): **INNOVATIVE SILICON S.A.** [CH/CH]; PSE-B, CH-1015 Lausanne (CH).
- (72) Inventor; and
- (75) Inventor/Applicant (for US only): **CARMAN, Eric** [US/FR]; Ancienne Fruitière, F-74350 Cernex (FR).
- (74) Agent: **STEINBERG, Neil, A.**; 2665 Marine Way, Suite 1150, Mountain View, CA 94043 (US).

- (81) Designated States (unless otherwise indicated, for every kind of national protection available): AE, AG, AL, AM, AT, AU, AZ, BA, BB, BG, BH, BR, BW, BY, BZ, CA, CH, CN, CO, CR, CU, CZ, DE, DK, DM, DZ, EC, EE, EG, ES, FI, GB, GD, GE, GH, GM, GT, HN, HR, HU, ID, IL, IN, IS, JP, KE, KG, KM, KN, KP, KR, KZ, LA, LC, LK, LR, LS, LT, LU, LY, MA, MD, MG, MK, MN, MW, MX, MY, MZ, NA, NG, NI, NO, NZ, OM, PG, PH, PL, PT, RO, RS, RU, SC, SD, SE, SG, SK, SL, SM, SV, SY, TJ, TM, TN, TR, TT, TZ, UA, UG, US, UZ, VC, VN, ZA, ZM, ZW.
- (84) Designated States (unless otherwise indicated, for every kind of regional protection available): ARIPO (BW, GH, GM, KE, LS, MW, MZ, NA, SD, SL, SZ, TZ, UG, ZM, ZW), Eurasian (AM, AZ, BY, KG, KZ, MD, RU, TJ, TM), European (AT, BE, BG, CH, CY, CZ, DE, DK, EE, ES, FI, FR, GB, GR, HU, IE, IS, IT, LT, LU, LV, MC, MT, NL, PL, PT, RO, SE, SI, SK, TR), OAPI (BF, BJ, CF, CG, CI, CM, GA, GN, GQ, GW, ML, MR, NE, SN, TD, TG).

**Declaration under Rule 4.17:**

— as to the applicant's entitlement to claim the priority of the earlier application (Rule 4.17(iii))

[Continued on next page]

(54) Title: MEMORY ARRAY HAVING A PROGRAMMABLE WORD LENGTH, AND METHOD OF OPERATING SAME

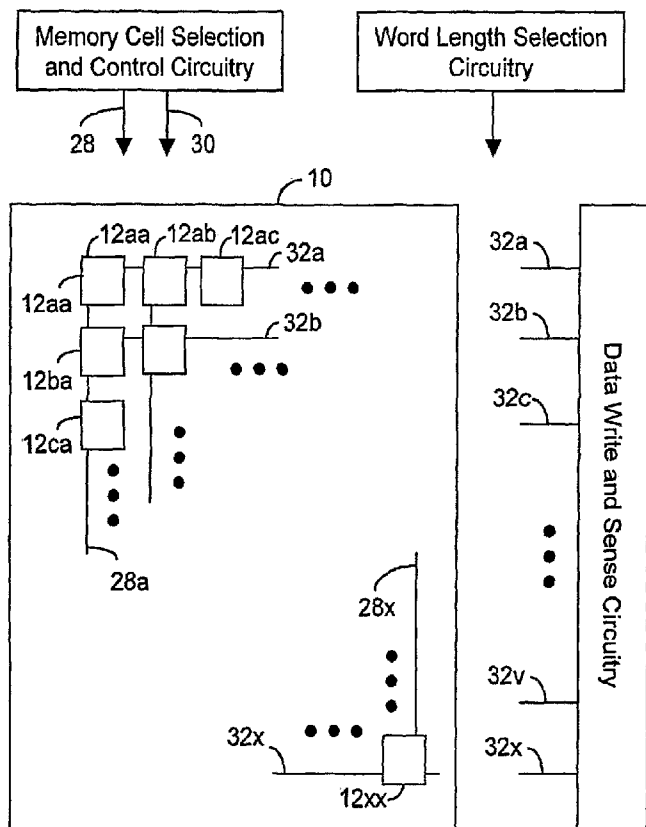

(57) Abstract: A memory cell array and device having a memory cell array (i.e., an integrated circuit device, for example, a logic device (such as, a microcontroller or microprocessor) or a memory device (such as, a discrete memory)) including electrically floating body transistors in which electrical charge is stored in the body of the transistor, and techniques for reading, controlling and/or operating such memory cell array and such device. The memory cell array and device include a variable and/or programmable word length. The word length relates to the selected memory cells of a selected row of memory cells (which is determined via address data). In one embodiment, the word length may be any number of memory cells of a selected row which is less than or equal to the total number of memory cells of the selected row of the memory array. In one aspect, write and/or read operations may be performed with respect to selected memory cells of a selected row of the memory array, while unselected memory cells of the selected row are undisturbed.

WO 2007/126830 A2



**Published:**

— without international search report and to be republished upon receipt of that report

*For two-letter codes and other abbreviations, refer to the "Guidance Notes on Codes and Abbreviations" appearing at the beginning of each regular issue of the PCT Gazette.*

# **Memory Array Having a Programmable Word Length, and Method of Operating Same**

## **RELATED APPLICATION**

This application claims priority to U.S. Provisional Application Serial No. 60/790,111, entitled "Memory Array Having a Programmable Word Length, and Technique of Implementing Same", filed April 7, 2006; the contents of this provisional application are incorporated by reference herein in its entirety.

## **BACKGROUND**

The present inventions relate to a memory cell, array, architecture and device, and techniques for reading, controlling and/or operating such cell and device; and more particularly, in one aspect, to a semiconductor dynamic random access memory ("DRAM") cell, array, architecture and/or device wherein the memory cell includes a transistor having an electrically floating body in which an electrical charge is stored.

There is a continuing trend to employ and/or fabricate advanced integrated circuits using techniques, materials and devices that improve performance, reduce leakage current and enhance overall scaling. Semiconductor-on-Insulator (SOI) is a material in which such devices may be fabricated or disposed on or in (hereinafter collectively "on"). Such devices are known as SOI devices and include, for example, partially depleted (PD), fully depleted (FD) devices, multiple gate devices (for example, double or triple gate), and Fin-FET.

One type of dynamic random access memory cell is based on, among other things, the electrically floating body effect of SOI transistors. (See, for example, U.S. Patent 6,969,662, incorporated herein by reference). In this regard, the dynamic random access memory cell may consist of a PD or a FD SOI transistor (or transistor formed in bulk material/substrate) having a channel, which is interposed between the body and the gate dielectric. The body region of the transistor is electrically floating in view of the insulation layer (or non-conductive region, for example, in a bulk-type material/substrate) disposed beneath the body region. The state of memory cell is determined by the concentration of charge within the body region of the SOI transistor.

With reference to FIGURES 1A, 1B and 1C, in one embodiment, semiconductor DRAM array 10 includes a plurality of memory cells 12 each consisting of transistor 14 having gate 16, body region 18, which is electrically floating, source region 20 and drain region 22. The body region 18 is disposed between source region 20 and drain region 22. Moreover, body region 18 is disposed on or above region 24, which may be an insulation region (for example, in an SOI material/substrate) or non-conductive region (for example, in a bulk-type material/substrate). The insulation or non-conductive region 24 may be disposed on substrate 26.

Data is written into or read from a selected memory cell by applying suitable control signals to a selected word line(s) 28, a selected source line(s) 30 and/or a selected bit line(s) 32. In response, charge carriers are accumulated in or emitted and/or ejected from electrically floating body region 18 wherein the data states are defined by the amount of carriers within electrically floating body region 18. Notably, the entire contents of the '662 Patent, including, for example, the features, attributes, architectures, configurations, materials, techniques and advantages described and illustrated therein, are incorporated by reference herein.

As mentioned above, memory cell 12 of DRAM array 10 operates by accumulating in or emitting/ejecting majority carriers (electrons or holes) 34 from body region 18 of, for example, N-channel transistors. (See, FIGURES 2A and 2B). In this regard, accumulating majority carriers (in this example, "holes") 34 in body region 18 of memory cells 12 via, for example, impact ionization near source region 20 and/or drain region 22, is representative of a logic high or "1" data state. (See, FIGURE 2A). Emitting or ejecting majority carriers 34 from body region 18 via, for example, forward biasing the source/body junction and/or the drain/body junction, is representative of a logic low or "0" data state. (See, FIGURE 2B).

Notably, for at least the purposes of this discussion, a logic high or State "1" corresponds to an increased concentration of majority carriers in the body region relative to an unprogrammed device and/or a device that is programmed with a logic low or State "0". In contrast, a logic low or State "0" corresponds to a reduced concentration of majority carriers in the body region relative to an unprogrammed device and/or a device that is programmed with logic high or State "1".

Conventional reading is performed by applying a small drain bias and a gate bias above the transistor threshold voltage. The sensed drain current is determined by the

charge stored in the floating body giving a possibility to distinguish between the states "1" and "0". A floating body memory device has two different current states corresponding to the two different logical states: "1" and "0".

In one conventional technique, the memory cell is read by applying a small bias to the drain of the transistor as well as a gate bias which is above the threshold voltage of the transistor. In this regard, in the context of memory cells employing N-type transistors, a positive voltage is applied to one or more word lines 28 to enable the reading of the memory cells associated with such word lines. The amount of drain current is determined/affected by the charge stored in the electrically floating body region of the transistor. As such, conventional reading techniques sense the amount of the channel current provided/generated in response to the application of a predetermined voltage on the gate of the transistor of the memory cell to determine the state of the memory cell; a floating body memory cell may have two or more different current states corresponding to two or more different logical states (for example, two different current conditions/states corresponding to the two different logical states: "1" and "0").

In short, conventional writing programming techniques for memory cells having an N-channel type transistor often provide an excess of majority carriers by channel impact ionization (see, FIGURE 3A) or by band-to-band tunneling (gate-induced drain leakage "GIDL") (see, FIGURE 3B). The majority carriers may be removed via drain side hole removal (see, FIGURE 4A), source side hole removal (see, FIGURE 4B), or drain and source hole removal, for example, using the back gate pulsing (see, FIGURE 4C).

Further, FIGURE 5 illustrates the conventional reading technique. In one embodiment, the state of the memory cell may be determined by sensing the amount of the channel current provided/generated in response to the application of a predetermined voltage on the gate of the transistor of the memory cell.

The memory cell 12 having electrically floating body transistor 14 may be programmed/read using other techniques including techniques that may, for example, provide lower power consumption relative to conventional techniques. For example, memory cell 12 may be programmed, read and/or controlled using the techniques and circuitry described and illustrated in U.S. Non-Provisional Patent Application Serial No. 11/509,188, filed on August 24, 2006, and entitled "Memory Cell and Memory Cell Array Having an Electrically Floating Body Transistor, and Methods of Operating Same"

(hereinafter "the '188 Application"), which is incorporated by reference herein. In one aspect, the '188 Application is directed to programming, reading and/or control methods which allow low power memory programming and provide larger memory programming window (both relative to at least the conventional programming techniques).

With reference to FIGURE 6, in one embodiment, the '188 Application employs memory cell 12 having electrically floating body transistor 14. The electrically floating body transistor 14, in addition to the MOS transistor, includes an intrinsic bipolar transistor (including, under certain circumstances, a significant intrinsic bipolar current). In this illustrative exemplary embodiment, electrically floating body transistor 14 is an N-channel device. As such, majority carriers are "holes".

With reference to FIGURE 7, in one embodiment, the '188 Application employs, writes or programs a logic "1" or logic high using control signals (having predetermined voltages, for example,  $V_g = 0v$ ,  $V_s = 0v$ , and  $V_d = 3v$ ) which are applied to gate 16, source region 20 and drain region 22 (respectively) of transistor 14 of memory cell 12. Such control signals induce or cause impact ionization and/or the avalanche multiplication phenomenon. (See, FIGURE 7). The predetermined voltages of the control signals, in contrast to the conventional method program or write logic "1" in the transistor of the memory cell via impact ionization and/or avalanche multiplication in the electrically floating body. In one embodiment, it is preferred that the bipolar transistor current responsible for impact ionization and/or avalanche multiplication in the floating body is initiated and/or induced by a control pulse which is applied to gate 16. Such a pulse may induce the channel impact ionization which increases the floating body potential and turns on the bipolar current. An advantage of the described method is that larger amount of the excess majority carriers is generated compared to other techniques.

Further, with reference to FIGURE 8, when writing or programming logic "0" in transistor 14 of memory cell 12, in one embodiment of the '188 Application, the control signals (having predetermined voltages (for example,  $V_g = 1.5v$ ,  $V_s = 0v$  and  $V_d = 0v$ ) are different and, in at least one embodiment, higher than a holding voltage (if applicable)) are applied to gate 16, source region 20 and drain region 22 (respectively) of transistor 14 of memory cell 12. Such control signals induce or provide removal of majority carriers from the electrically floating body of transistor 14. In one embodiment, the majority carriers are removed, eliminated or ejected from body region 18 through source

region 20 and drain region 22. (See, FIGURE 8). In this embodiment, writing or programming memory cell 12 with logic "0" may again consume lower power relative to conventional techniques.

When memory cell 12 is implemented in a memory cell array configuration, it may be advantageous to implement a "holding" operation for certain memory cells 12 when programming one or more other memory cells 12 of the memory cell array to enhance the data retention characteristics of such certain memory cells 12. The transistor 14 of memory cell 12 may be placed in a "holding" state via application of control signals (having predetermined voltages) that are applied to gate 16 and source region 20 and drain region 22 of transistor 14 of memory cell 12. In combination, such control signals provide, cause and/or induce majority carrier accumulation in an area that is close to the interface between gate dielectric 32 and electrically floating body region 18. (See, FIGURE 9). In this embodiment, it may be preferable to apply a negative voltage to gate 16 where transistor 14 is an N-channel type transistor.

With reference to FIGURE 10, in one embodiment of the '188 Application, the data state of memory cell 12 may be read and/or determined by applying control signals (having predetermined voltages, for example,  $V_g = -0.5v$ ,  $V_s = 3v$  and  $V_d = 0v$ ) to gate 16 and source region 20 and drain region 22 of transistor 14. Such signals, in combination, induce and/or cause the bipolar transistor current in those memory cells 12 storing a logic state "1". For those memory cells that are programmed to a logic state "0", such control signals do not induce and/or cause a considerable, substantial or sufficiently measurable bipolar transistor current in the cells programmed to "0" state. (See, the '188 Application, which, as noted above, is incorporated by reference).

As mentioned above, the reading may be performed using positive voltages applied to word lines 28. As such, transistors 14 of device 10 are periodically pulsed between a positive gate bias, which (1) drives majority carriers (holes for N-channel transistors) away from the interface between gate insulator 32 and body region 18 of transistor 14 and (2) causes minority carriers (electrons for N-channel transistors) to flow from source region 20 and drain region 22 into a channel formed below gate 16, and the negative gate bias, which causes majority carriers (holes for N-channel transistors) to accumulate in or near the interface between gate 16 and body region 18 of transistor 14.

With continued reference to FIGURES 11 and 12, in this exemplary embodiment of the '188 Application, control signals having predetermined amplitudes may be applied to memory cells 12b and 12c to write or program logic state "0" therein. In this exemplary embodiment, the source pulse may be applied to source region 20 of memory cells 12b and 12c before the gate pulse is applied to gate 16 of memory cells 12b and 12c, or simultaneously thereto, or after the gate pulse is applied to gate 16 of memory cells 12b and 12c. In this exemplary embodiment, a drain pulse (0.5V amplitude in this example) is applied to drain regions 22 of memory cells 12b and 12d to prevent, prohibit, limit and/or retard a bipolar current (if any) from causing or generating a sufficient charge in the floating body region of memory cells 12b and 12c to program or write a logic state "1" into memory cells 12b and 12c. The drain pulse prevents bipolar current and the write of a logic state "1" but is not high enough to block the ejection of majority charges from the floating body region, thus a logic state "0" is written.

From a relative timing perspective, it is preferred that the drain pulse be applied to drain region 22 of memory cells 12b and 12c for a temporal period that extends or is applied before, during and after the source and gate pulses (for example, initiates, starts, ramps, declines and/or terminates) as illustrated in FIGURE 11.

Notably, with continued reference to FIGURES 11 and 12, for those unselected memory cells (i.e., the memory cells coupled to word lines  $28_{i+1}$ ,  $28_{i+2}$  and  $28_{i+3}$ ), a holding condition may be applied or established to prevent, minimize or avoid disturbance of the data state of, or charge stored in the unselected memory cells. In this regard, a voltage (for example, -1.2V) may be applied to gates 16 of the unselected memory cells and a voltage (for example, 0V) may be applied to source regions 20 and drain regions 22 of the unselected memory cells to prevent, minimize or avoid disturbance of the data state in the unselected memory cells during the programming or writing operation. Under these conditions, the data state of the unselected memory cells is unaffected (or substantially unaffected) by the programming of or writing to selected memory cells 12a-d.

With reference to FIGURES 11 and 13, in an exemplary embodiment described and illustrated in the '188 Application, control signals having a predetermined amplitude may be selectively applied to a row of memory cells (for example, memory cells 12a-d) to read the data state in each of the selected memory cells 12a-12d. In this exemplary

embodiment, a voltage pulse of 3V may be applied to source region 20, and a voltage pulse of -0.5V may be applied to gate 16 of memory cells 12a-d. In this embodiment, the source pulse may be applied to source region 20 before application of the gate pulse to gate 16, simultaneously thereto, or after the gate pulse is applied to gate 16. Further, the source pulse may cease or terminate before the gate pulse, simultaneously thereto (as illustrated in FIGURE 11), or after the gate pulse concludes or ceases.

Notably, for those memory cells that are not read (i.e., those memory cells coupled to word lines  $28_{i+1}$ ,  $28_{i+2}$  and  $28_{i+3}$ ), a holding condition may be applied or established to prevent, minimize or avoid disturbance of the data state in the unselected memory cells. In this regard, a voltage (for example, -1.2V) may be applied to gates 16 of the unselected memory cells and a voltage (for example, 0V) may be applied to source regions 20 of the unselected memory cells to prevent, minimize or avoid disturbance of the data state in the unselected memory cells during the read operation. Under these conditions, the state of the unselected memory cells is unaffected (or it is substantially unaffected) during the reading of selected memory cells 12a-d.

The illustrated/exemplary voltage levels to implement the write and read operations, with respect to the '188 Application are merely exemplary. The indicated voltage levels may be relative or absolute. Alternatively, the voltages indicated may be relative in that each voltage level, for example, may be increased or decreased by a given voltage amount (for example, each voltage may be increased or decreased by 0.25, 0.5, 1.0 and 2.0 volts) whether one or more of the voltages (for example, the source, drain or gate voltages) become or are positive and negative.

### **SUMMARY OF THE INVENTIONS**

There are many inventions described and illustrated herein. The present inventions are neither limited to any single aspect nor embodiment thereof, nor to any combinations and/or permutations of such aspects and/or embodiments. Moreover, each of the aspects of the present inventions, and/or embodiments thereof, may be employed alone or in combination with one or more of the other aspects of the present inventions and/or embodiments thereof. For the sake of brevity, many of those permutations and combinations will not be discussed separately herein.

In a first principle aspect, the present inventions are directed to an integrated circuit device (for example, a logic or discrete memory device) comprising a memory cell array having a plurality of word lines, a plurality of source lines, a plurality of bit lines, and a plurality of memory cells arranged in a matrix of rows and columns, wherein each memory cell includes an electrically floating body transistor. The electrically floating body transistor (for example, an N-channel type transistor or a P-channel type transistor) includes a first region coupled to an associated source line, a second region coupled to an associated bit line, a body region disposed between the first region and the second region, wherein the body region is electrically floating, and a gate disposed over the body region and coupled to an associated word line. The memory cell includes a plurality of data states, including (i) a first data state which is representative of a first charge in the body region of the electrically floating body transistor and (ii) a second data state which is representative of a second charge in the body region of the electrically floating body transistor.

The integrated circuit device of this aspect further includes first circuitry, coupled to each memory cell of a first row of memory cells, to concurrently apply (i) write control signals to a first group of memory cells of the first row of memory cells to write one of the plurality of data states therein, and (ii) write de-select control signals to a second group of memory cells of the first row of memory cells to inhibit writing of write one of the plurality of data states therein.

The number of memory cells of the first group of memory cells may correspond to a word length of the memory cell array. In one embodiment, the integrated circuit device includes word length selection circuitry (for example, fuses or anti-fuses, or DRAM, SRAM, ROM, PROM, EPROM, EEPROM cells, latches, registers, and/or fixed via, for example, voltages applied to signal lines or pins) to store data which is representative of the word length.

In one embodiment, the write de-select control signals include: (i) a first temporally changing signal applied to the gate of each memory cell of the second group of memory cells, (ii) a second temporally changing signal applied to the first region of each memory cell of the second group of memory cells, and (iii) a third temporally changing signal applied to the second region of each memory cell of the second group of memory cells. In this embodiment, the write control signals may include: (i) the first temporally changing signal applied to the gate of each memory cell of the first group of

memory cells, (ii) the second temporally changing signal applied to the first region of each memory cell of the first group of memory cells, and (iii) a fourth temporally changing signal applied to the second region of each memory cell of the first group of memory cells.

In another embodiment, the write de-select control signals include: (i) a first temporally changing signal applied to the gate of each memory cell of the second group of memory cells, (ii) a second temporally changing signal applied to the first region of each memory cell of the second group of memory cells, and (iii) a third signal having a substantially constant voltage amplitude applied to the second region of each memory cell of the second group of memory cells. In this embodiment, the write control signals may include: (i) the first temporally changing signal applied to the gate of each memory cell of the first group of memory cells, (ii) the second temporally changing signal applied to the first region of each memory cell of the first group of memory cells, and (iii) a fourth temporally changing signal applied to the second region of each memory cell of the first group of memory cells.

The integrated circuit device may further include second circuitry, coupled to each memory cell of the first row of memory cells, to concurrently apply: (i) read control signals to the first group of memory cells of the first row of memory cells to read the data state of each memory cell of the first group of memory cells, and (ii) read de-select control signals to the second group of memory cells of the first row of memory cells to inhibit reading the data state of each memory cell of the second group of memory cells.

The read control signals may include a signal applied to the gate, a signal applied to the first region, and a signal applied to the second region of the electrically floating body transistor of each memory cell of the first group of memory cells to cause, force and/or induce a read bipolar transistor current which is representative of the data state of each memory cell of the first group of memory cells of the first row of memory cells.

In one embodiment, the second circuitry determines the data state of the memory cell substantially based on the read bipolar transistor current. Indeed, the second circuitry may include a plurality of sense amplifiers.

In another embodiment, the write control signals include control signals to write the first data state and wherein, in response to the control signals to write the first data state into a predetermined memory cell of the first row of memory cells, the electrically floating body transistor of the predetermined memory cell of the first row of memory cells

generates a bipolar transistor current which substantially provides the first charge in the body region of the electrically floating body transistor of the predetermined memory cell of the first row of memory cells.

In one embodiment, the memory cells may store more than one data bit (for example, two, three, four, five, six, etc.) and/or more than two data states (for example, three, four, five, six, etc. data or logic states). As such, each memory cell of the memory cell array may include a third data state which is representative of a third charge in the body region of the electrically floating body transistor.

In another principle aspect, the present inventions are directed to an integrated circuit device (for example, a logic or discrete memory device) comprising a memory cell array having a plurality of word lines, a plurality of source lines, a plurality of bit lines, and a plurality of memory cells arranged in a matrix of rows and columns, wherein each memory cell includes an electrically floating body transistor. The electrically floating body transistor (for example, an N-channel type transistor or a P-channel type transistor) includes a first region coupled to an associated source line, a second region coupled to an associated bit line, a body region disposed between the first region and the second region, wherein the body region is electrically floating, and a gate disposed over the body region and coupled to an associated word line. The memory cell includes a plurality of data states, including (i) a first data state which is representative of a first charge in the body region of the electrically floating body transistor and (ii) a second data state which is representative of a second charge in the body region of the electrically floating body transistor.

The integrated circuit device of this aspect further includes circuitry (for example, a plurality of sense amplifiers), coupled to each memory cell of the first row of memory cells, to substantially concurrently apply: (i) read control signals to a first group of memory cells of the first row of memory cells to read the data state of each memory cell of the first group of memory cells, and (ii) read de-select control signals to a second group of memory cells of the first row of memory cells to inhibit reading the data state of each memory cell of the second group of memory cells.

In one embodiment, the read control signals include a signal applied to the gate, a signal applied to the first region, and a signal applied to the second region of the electrically floating body transistor of each memory cell of the first group of memory cells to cause, force and/or induce a read bipolar transistor current which is representative of

the data state of each memory cell of the first group of memory cells of the first row of memory cells. In this embodiment, the circuitry may determine the data state of the memory cell substantially based on the read bipolar transistor current.

In one embodiment, the integrated circuit device may further include write circuitry, coupled to each memory cell of a first row of memory cells, to concurrently apply: (i) write control signals to a first group of memory cells of the first row of memory cells to write one of the plurality of data states therein, and (ii) write de-select control signals to a second group of memory cells of the first row of memory cells to inhibit the writing of write one of the plurality of data states therein. The write control signals include control signals to write the first data state and wherein, in response to the control signals to write the first data state into a predetermined memory cell of the first row of memory cells, the electrically floating body transistor of the predetermined memory cell of the first row of memory cells generates a bipolar transistor current which substantially provides the first charge in the body region of the electrically floating body transistor of the predetermined memory cell of the first row of memory cells.

The number of memory cells of the first group of memory cells may correspond to a word length of the memory cell array. In one embodiment, the integrated circuit device includes word length selection circuitry (for example, fuses or anti-fuses, or DRAM, SRAM, ROM, PROM, EPROM, EEPROM cells, latches, registers, and/or fixed via, for example, voltages applied to signal lines or pins) to store data which is representative of the word length.

In yet another principle aspect, the present inventions are directed to an integrated circuit device (for example, a logic or discrete memory device) comprising a semiconductor memory array, disposed in or on a semiconductor region or layer which resides on or above an insulating region or layer of a substrate. The semiconductor memory array includes a plurality of word lines, a plurality of source lines, a plurality of bit lines, and a plurality of memory cells arranged in a matrix of rows and columns, wherein each memory cell includes an electrically floating body transistor. The electrically floating body transistor (for example, an N-channel type transistor or a P-channel type transistor) includes a first region coupled to an associated source line, a second region coupled to an associated bit line, a body region disposed between the first region and the second region, wherein the body region is electrically floating, and a gate disposed over the body region and coupled to an associated word line. The

memory cell includes a plurality of data states, including (i) a first data state which is representative of a first charge in the body region of the electrically floating body transistor and (ii) a second data state which is representative of a second charge in the body region of the electrically floating body transistor.

The integrated circuit device of this aspect also includes first circuitry, coupled to each memory cell of a first row of memory cells, to concurrently apply (i) write control signals to a first group of memory cells of the first row of memory cells to write one of the plurality of data states therein, and (ii) write de-select control signals to a second group of memory cells of the first row of memory cells to inhibit writing of write one of the plurality of data states therein

The integrated circuit device of this aspect further includes second circuitry (for example, a plurality of sense amplifiers), coupled to each memory cell of the first row of memory cells, to substantially concurrently apply: (i) read control signals to a first group of memory cells of the first row of memory cells to read the data state of each memory cell of the first group of memory cells, and (ii) read de-select control signals to a second group of memory cells of the first row of memory cells to inhibit reading the data state of each memory cell of the second group of memory cells.

In one embodiment, the read control signals include a signal applied to the gate, a signal applied to the first region, and a signal applied to the second region of the electrically floating body transistor of each memory cell of the first group of memory cells to cause, force and/or induce a read bipolar transistor current which is representative of the data state of each memory cell of the first group of memory cells of the first row of memory cells. In this embodiment, the second circuitry determines the data state of the memory cell substantially based on the read bipolar transistor current.

In one embodiment, the write control signals include control signals to write the first data state and wherein, in response to the control signals to write the first data state into a predetermined memory cell of the first row of memory cells, the electrically floating body transistor of the predetermined memory cell of the first row of memory cells generates a bipolar transistor current which substantially provides the first charge in the body region of the electrically floating body transistor of the predetermined memory cell of the first row of memory cells.

The number of memory cells of the first group of memory cells may correspond to a word length of the memory cell array. In one embodiment, the integrated circuit

device includes word length selection circuitry (for example, fuses or anti-fuses, or DRAM, SRAM, ROM, PROM, EPROM, EEPROM cells, latches, registers, and/or fixed via, for example, voltages applied to signal lines or pins) to store data which is representative of the word length.

As noted above, the memory cells may store more than one data bit (for example, two, three, four, five, six, etc.) and/or more than two data states (for example, three, four, five, six, etc. data or logic states). As such, each memory cell of the memory cell array may include a third data state which is representative of a third charge in the body region of the electrically floating body transistor.

Again, there are many inventions, and aspects of the inventions, described and illustrated herein. This Summary of the Inventions is not exhaustive of the scope of the present inventions. Moreover, this Summary of the Inventions is not intended to be limiting of the inventions and should not be interpreted in that manner. While certain embodiments have been described and/or outlined in this Summary of the Inventions, it should be understood that the present inventions are not limited to such embodiments, description and/or outline, nor are the claims limited in such a manner (which should also not be interpreted as being limited by the Summary of the Inventions). Indeed, many other aspects, inventions and embodiments, which may be different from and/or similar to, the aspects, inventions and embodiments presented in this Summary, will be apparent from the description, illustrations and claims, which follow. In addition, although various features, attributes and advantages have been described in this Summary of the Inventions and/or are apparent in light thereof, it should be understood that such features, attributes and advantages are not required whether in one, some or all of the embodiments of the present inventions and, indeed, need not be present in any of the embodiments of the present inventions.

#### **BRIEF DESCRIPTION OF THE DRAWINGS**

In the course of the detailed description to follow, reference will be made to the attached drawings. These drawings show different aspects of the present inventions and, where appropriate, reference numerals illustrating like structures, components, materials and/or elements in different figures are labeled similarly. It is understood that

various combinations of the structures, components, materials and/or elements, other than those specifically shown, are contemplated and are within the scope of the present inventions.

Moreover, there are many inventions described and illustrated herein. The present inventions are neither limited to any single aspect nor embodiment thereof, nor to any combinations and/or permutations of such aspects and/or embodiments. Moreover, each of the aspects of the present inventions, and/or embodiments thereof, may be employed alone or in combination with one or more of the other aspects of the present inventions and/or embodiments thereof. For the sake of brevity, many of those permutations and combinations will not be discussed separately herein.

FIGURE 1A is a schematic representation of a prior art DRAM array including a plurality of memory cells comprised of one electrically floating body transistor;

FIGURE 1B is a three dimensional view of an exemplary prior art memory cell comprised of one electrically floating body transistor (PD-SOI NMOS);

FIGURE 1C is a cross-sectional view of the prior art memory cell of FIGURE 1B, cross-sectioned along line C-C';

FIGURES 2A and 2B are exemplary schematic illustrations of the charge relationship, for a given data state, of the floating body, source and drain regions of a prior art memory cell comprised of one electrically floating body transistor (PD-SOI NMOS);

FIGURES 3A and 3B are exemplary schematic and general illustrations of conventional methods to program a memory cell to logic state "1" (i.e., generate or provide an excess of majority carrier in the electrically floating body of the transistor (an N-type channel transistor in this exemplary embodiment) of the memory cell of FIGURE 1B; majority carriers in these exemplary embodiments are generated or provided by the channel electron impact ionization (FIGURE 3A) and by GIDL or band to band tunneling (FIGURE 3B));

FIGURES 4A-4C are exemplary schematics and general illustrations of conventional methods to program a memory cell to logic state "0" (i.e., provide relatively fewer majority carriers by removing majority carriers from the electrically floating body of the transistor of the memory cell of FIGURE 1B; majority carriers may be removed through the drain region/terminal of the transistor (FIGURE 4A), the source region/terminal of the transistor (FIGURE 4B), and through both drain and source

regions/terminals of the transistor by using, for example, the back gate pulses applied to the substrate/backside terminal of the transistor of the memory cell (FIGURE 4C));

FIGURE 5 illustrates an exemplary schematic (and control signal) of a conventional reading technique, the state of the memory cell may be determined by sensing the amount of the channel current provided/generated in response to the application of a predetermined voltage on the gate of the transistor of the memory cell;

FIGURE 6 is a schematic representation of an equivalent electrically floating body memory cell (N-channel type) including an intrinsic bipolar transistor in addition to the MOS transistor;

FIGURE 7 illustrates an exemplary schematic (and control signal voltage relationship) of an exemplary embodiment of an aspect of the '188 Application of programming a memory cell to logic state "1" by generating, storing and/or providing an excess of majority carriers in the electrically floating body of the transistor of the memory cell;

FIGURE 8 illustrates an exemplary schematic (and control signals) of an exemplary embodiment of an aspect of the '188 Application of programming a memory cell to a logic state "0" by generating, storing and/or providing relatively fewer majority carriers (as compared to the number of majority carriers in the electrically floating body of the memory cell that is programmed to a logic state "1") in the electrically floating body of the transistor of the memory cell, wherein the majority carriers are removed (write "0") through both drain and source terminals by applying a control signal (for example, a programming pulse) to the gate of the transistor of the memory cell;

FIGURE 9 illustrates an exemplary schematic (and control signals) of an exemplary embodiment of an aspect of the '188 Application of holding or maintaining the data state of a memory cell;

FIGURE 10 illustrates an exemplary schematic (and control signals) of an exemplary embodiment of an aspect of the '188 Application of reading the data state of a memory cell by sensing the amount of the current provided/generated in response to an application of a predetermined voltage on the gate of the transistor of the memory cell;

FIGURE 11 illustrates exemplary timing relationships of selected write control signals to (i) program or write a logic state "1" into one or more N-channel type memory cells, (ii) program or write logic state "0" into one or more N-channel type memory cells,

and (iii) read one or more N-channel type memory cells according to one embodiment of the inventions described and illustrated in the '188 Application;

FIGURES 12 and 13 illustrate an exemplary embodiment of a memory array having a plurality of memory cells (N-channel type) and employing a separated source line configuration for each row of memory cells in conjunction with exemplary programming techniques, including exemplary control signal voltage values (FIGURE 11) and exemplary reading techniques, including exemplary control signal voltage values (FIGURE 12), according to certain aspects of the inventions described and illustrated in the '188 Application;

FIGURE 14 illustrates exemplary timing relationships of selected write control signals to (i) program or write a logic state "1" into one or more P-channel type memory cells, (ii) program or write logic state "0" into one or more P-channel type memory cells, and (iii) read one or more P-channel type memory cells according to one embodiment of the '188 Application;

FIGURE 15 illustrates an exemplary embodiment of a memory array employing a common source line configuration for each row of memory cells in conjunction with control signal voltages to write/program selected memory cells of a selected row of memory cells and control voltages to de-select or "block" the write/program operation of unselected memory cells of the selected row of memory cells, in accordance with certain aspect of the present inventions; and

FIGURE 16 illustrates an exemplary embodiment of a memory array employing a common source line configuration for each row of memory cells in conjunction with control signal voltages to read the data state of selected memory cells of a selected row of memory cells and control voltages to de-select or "block" the read operation of unselected memory cells of the selected row of memory cells, in accordance with certain aspect of the present inventions;

FIGURES 17, 18, and 19 illustrate exemplary timing relationships of selected write control signals to (i) de-select, program or write of logic state "1" into one or more N-channel type memory cells, (ii) de-select, program or write of logic state "0" into one or more N-channel type memory cells, and (iii) de-select or read of one or more N-channel type memory cells, in accordance with certain aspect of the present inventions, wherein the de-select control signal includes a pulsed characteristic (see, FIGURE 17) and a non-pulsed characteristic (see, FIGURES 18 and 19);

FIGURES 20A-20C are schematic block diagram illustrations of exemplary integrated circuit devices in which the memory cell array (and certain peripheral circuitry) may be implemented, according to one or more aspects of the present inventions;

FIGURES 20D and 20E are schematic block diagrams of embodiments of an integrated circuit device including, among other things, a memory cell array, data sense and write circuitry, memory cell selection and control circuitry, according to one or more aspects of the present inventions; and

FIGURES 21A-21C are schematic representations of exemplary architectures and/or embodiments of implementing a controller/processor in conjunction with memory devices having a programmable word length, in accordance with one or more aspects of the present inventions.

### **DETAILED DESCRIPTION**

In one aspect, the present inventions are directed to techniques for reading, controlling and/or operating a semiconductor memory cell, array, architecture and device (i.e., an integrated circuit device, for example, a logic device (such as, a microcontroller or microprocessor) or a memory device (such as, a discrete memory)) including electrically floating body transistors in which electrical charge is stored in the body of the transistor. The present inventions are also directed to semiconductor memory cell, array, architecture and device that include circuitry to implement such reading, controlling and/or operating techniques.

In one embodiment, the word length (which relates to the selected memory cells of a given/predetermined selected row of memory cells) of the memory cell array is variable and/or programmable. The word length may be an amount equal to any number of memory cells of a selected row which is less than or equal to the total number of memory cells of the selected row of the memory array. In one aspect of the inventions, write and/or read operations may be performed with respect to selected memory cells (i.e., a first group of memory cells) of a selected row of the memory array, while unselected memory cells (i.e., a second group of memory cells) of the selected row are undisturbed.

Although not limited thereto, in certain aspects the present inventions will be described in the context of an embodiment of the '188 Application wherein the word length of the memory array is variable and/or programmable.

With reference to FIGURES 15, 17, and 18 in an exemplary embodiment, exemplary control signals having predetermined amplitude may be selectively applied (based on address data) to a given/predetermined row of memory cells (for example, memory cells 12a-d which are connected to the same word line, namely word line 28<sub>i</sub>) to write logic state "1" into selected memory cell 12a, and logic state "0" into selected memory cell 12b. Concurrently or substantially concurrently (hereinafter collectively, "concurrently") therewith, exemplary "write de-select" control signals, having predetermined amplitude, are applied to unselected memory cells 12c and 12d to prevent, inhibit and/or disable the write operation so that memory cells 12c and 12d of the selected row of memory cells remain in their existing memory states "0" and "1", respectively. In this regard, a "write de-select" voltage pulse is applied to bit lines 32<sub>j+2</sub> and 32<sub>j+3</sub> to prevent, inhibit and/or disable the write operation with respect to memory cells 12c and 12d by preventing, minimizing, eliminating and/or blocking charge loss for the case of a cell previously written to logic state "1" (here, memory cell 12c), or preventing, minimizing, eliminating bipolar current generation for the case of a cell previously written to logic state "0" (here, memory cell 12d). With the application of the de-select control signal to bit lines 32<sub>j+2</sub> and 32<sub>j+3</sub>, the data states of memory cells 12c and 12d are not disturbed or adversely affected – notwithstanding that such memory cells are a portion of the selected row of memory cells (based on address data). Notably, the de-select control signals may be applied to bit lines 32<sub>j+2</sub> and 32<sub>j+3</sub> as a voltage pulse, as illustrated in FIGURE 17, during the write operation or may be applied continuously to bit lines 32<sub>j+2</sub> and 32<sub>j+3</sub>, as illustrated in FIGURE 18.

With reference to FIGURES 16-19 in an exemplary embodiment, control signals, having predetermined amplitude, are selectively applied (based on address data) to a predetermined or given row of memory cells (for example, memory cells 12a-d which are connected to the same word line, namely word line 28<sub>i</sub>) to read selected memory cells 12a and 12b. Concurrently therewith, exemplary "read de-select" control signals, having predetermined amplitude, are applied to unselected memory cells 12c and 12d to prevent, inhibit and/or disable the read operation so that memory cells 12c and 12d of the selected row of memory cells are not impacted by the read operation. In this regard,

a "read de-select" voltage pulse or constant voltage is applied to bit lines  $32_{j+2}$  and  $32_{j+3}$  to prevent, inhibit and/or disable the read operation with respect to memory cells 12c and 12d – notwithstanding that such memory cells are a portion of the selected row of memory cells. As such, memory cells 12c and 12d are not read, impacted and/or adversely affected by the read operation. In this embodiment, memory cells 12c and 12d do not significantly conduct current during a read operation and are not disturbed – notwithstanding the access of the row of memory cells via word line  $28_i$ .

The voltage amplitudes illustrated in FIGURES 15-19 (among others) to perform selected operations (for example, read, write, read de-select, write de-select, hold) are merely exemplary. The indicated voltage levels may be relative or absolute. Alternatively, as mentioned above, the voltages indicated may be relative in that each voltage level, for example, may be increased or decreased by a given voltage amount (for example, each voltage may be increased/decreased by 0.25, 0.5, 1.0 and 2.0 volts (or more)) whether one or more of the voltages (for example, the source, drain or gate voltages) become or are positive and negative.

Notably, the present inventions may have several advantages over prior art techniques which typically include a long row memory cell array for area efficiency with pipeline techniques because of the resulting difference between array word length and input/output word length. Because with the present inventions, the selected memory cells of the selected row are written or read and unselected memory cells of the selected row are not adversely affected by the predetermined operation, the word length of the memory array may be the same as the input/output word length in spite of maintaining a long row memory cell array for area efficiency. In the present inventions, the selected memory cells of the selected row is written or read (while the unselected memory cells of the selected row do not participate in or are not adversely affected by the operation) so in cases where data addresses are not consecutive and pipeline techniques are not effective, power management is enhanced because the unselected memory cells (which are presumably not needed) are not read from during the read operation or written into during the write operation.

In addition, because memory cell array word length and input/output word length are the same, data may be written into or read from the memory array in a single step or stage which may provide for faster operation and/or lower power consumption. In this regard, conventional techniques often employ a two step or stage write to first write data

into latches and then write data from latches to memory cells. Similarly, for read operations, data is first read from the memory cell array into latches and thereafter to the output. The present inventions also allow the word length to be changed between operations at any time, for example, by control of the data write and sense circuitry and memory cell selection and control circuitry.

The word length may be set and/or controlled, for example, at fabrication, during test, and/or in situ. For example, the integrated circuit device may be programmed (i) after power-up, for example, during an initialization phase, or (ii) during operation to minimize power consumption and maximize speed. For example, during operation, the word length of the random accesses may be set to match the I/O width for maximum speed. However, where the data addresses are consecutive, a word length may be set to equal the number of physical bits on a row so data would first be written to latches and then written to an entire row in one operation for lower power consumption. Consecutive data addresses may be indicated by an external input to the memory of the integrated circuit, or consecutive addresses could be detected internal to the memory of the integrated circuit. With respect to refresh operations for which no data is input or output from the memory but all bits on a row must be refreshed, a word length equal to the number of physical bits on a row may be set. In this way, power consumption may be reduced and/or minimized.

Notably, word length of the memory array of the integrated circuit (for example, a processor device or a discrete memory device) may be one time programmable (for example, programmed during test or at manufacture) or more than one time programmable (for example, during test, start-up/power-up, during an initialization sequence and/or during operation (in situ)). For example, in one embodiment, the word length may be "stored" in word length selection circuitry that resides on the integrated circuit (for example, fuses or anti-fuses, or DRAM, SRAM, ROM, PROM, EPROM, EEPROM cells, latches, registers, and/or fixed via, for example, voltages applied to signal lines or pins). (See, for example, FIGURES 20C and 20D). Indeed, any programming technique and/or circuitry, whether now known or later developed, are intended to fall within the scope of the present inventions.

The control circuitry to determine, implement and/or program the word length may be implemented on-chip, which is resident on (i.e., integrated in) the device, or off-chip (i.e., disposed on or in a different integrated circuit device, for example, disposed

on/in a memory controller, microprocessor and/or graphics processor). The control circuitry may implement any programming technique and/or circuitry, whether now known or later developed; all such techniques and circuitry are intended to fall within the scope of the present inventions.

As noted above, the memory cell and/or memory cell array, as well as the circuitry of the present inventions may be implemented in an integrated circuit device having a memory portion and a logic portion (see, for example, FIGURES 20A and 20C), or an integrated circuit device that is primarily a memory device (see, for example, FIGURE 20B). The memory array may include a plurality of memory cells arranged in a plurality of rows and columns wherein each memory cell includes an electrically floating body transistor. The memory arrays may be comprised of N-channel, P-channel and/or both types of transistors. Indeed, circuitry that is peripheral to the memory array (for example, data sense circuitry (for example, sense amplifiers or comparators), memory cell selection and control circuitry (for example, word line and/or source line drivers), as well as row and column address decoders) may include P-channel and/or N-channel type transistors.

For example, with reference to FIGURES 20D and 20E, the integrated circuit device may include array 10, having a plurality of memory cells 12, data write and sense circuitry, and memory cell selection and control circuitry. The data write and sense circuitry reads data from and writes data to selected memory cells 12. In one embodiment, the data write and sense circuitry includes a plurality of data sense amplifiers. Each data sense amplifier receives at least one bit line 32 and an output of reference generator circuitry (for example, a current or voltage reference signal). In one embodiment, the data sense amplifier may be one or more of the cross-coupled type sense amplifiers like the cross-coupled type sense amplifier described and illustrated in the Non-Provisional U.S. Patent Application Serial No. 11/299,590 (U.S. Patent Application Publication US 2006/0126374), filed by Waller and Carman, on December 12, 2005, and entitled "Sense Amplifier Circuitry and Architecture to Write Data into and/or Read Data from Memory Cells", the application being incorporated herein by reference in its entirety) to sense the data state stored in memory cell 12 and/or write-back data into memory cell 12.

The present inventions may be implemented in any electrically floating body memory cell and memory cell array. (See, for example, the Background section above).

Indeed, in certain aspects, the present inventions are a memory array, having a plurality of memory cells each including an electrically floating body transistor, and/or technique of writing or programming data into one or more memory cells of such a memory array. In this aspect of the inventions, the data states of adjacent memory cells and/or memory cells that share a word line may be individually programmed. In addition, although the present inventions has been described, by way of example, in the context of an embodiment of the '188 Application, the present inventions may be implemented in or with other memory cell and memory array technologies, for example, 1T-1C (one transistor, one capacitor) and electrically floating gate memory cells.

The memory arrays may be comprised of N-channel, P-channel and/or both types of transistors. Indeed, circuitry that is peripheral to the memory array (for example, sense amplifiers or comparators, row and column address decoders, as well as line drivers (not illustrated herein)) may include P-channel and/or N-channel type transistors.

Where P-channel type transistors are employed as memory cells 12 in the memory array(s), there are many suitable write and read voltages (for example, negative voltages). (See, for example, FIGURE 14). For example, the data may be read from P-channel type memory cells by applying a voltage pulse of -3V to the source region, and a voltage pulse of 0.5V may be applied to the gate of the memory cells to be read. In this embodiment, the source pulse may be applied to the source region before application of the gate pulse to the gate, simultaneously thereto, or after the gate pulse is applied the gate. Further, the source pulse may cease or terminate before the gate pulse, simultaneously thereto (as illustrated in FIGURE 14), or after the gate pulse concludes or ceases.

As mentioned above, the circuitry and techniques of the present inventions may be employed in conjunction with any electrically floating body memory cell (i.e., a memory cell including at least one electrically floating body transistor), and/or architecture, layout, structure and/or configuration employing such electrically floating body memory cells (among other types of memory cells). For example, an electrically floating body transistor, whose state is read, programmed and/or controlled using the techniques of the present inventions, may be implemented in the memory cell, architecture, layout, structure and/or configuration described and illustrated in the following provisional and non-provisional U.S. patent applications:

(1) U.S. Non-Provisional Patent Application Serial No. 10/450,238, which was filed by Fazan et al. on June 10, 2003 and entitled "Semiconductor Device" (now U.S. Patent 6,969,662);

(2) U.S. Non-Provisional Patent Application Serial No. 10/487,157, which was filed by Fazan et al. on February 18, 2004 and entitled "Semiconductor Device" (now U.S. Patent 7,061,050);

(3) U.S. Non-Provisional Patent Application Serial No. 10/829,877, which was filed by Ferrant et al. on April 22, 2004 and entitled "Semiconductor Memory Cell, Array, Architecture and Device, and Method of Operating Same" (now U.S. Patent 7,085,153);

(4) U.S. Non-Provisional Patent Application Serial No. 11/096,970, which was filed by Ferrant et al. and entitled "Semiconductor Memory Device and Method of Operating Same" (now U.S. Patent 7,085,156);

(5) U.S. Non-Provisional Patent Application Serial No. 10/941,692, which was filed by Fazan et al. on September 15, 2004 and entitled "Low Power Programming Technique for a One Transistor SOI Memory Device & Asymmetrical Electrically Floating Body Memory Device, and Method of Manufacturing Same" (U.S. Patent Application Publication No. 2005/0063224);

(6) U.S. Non-Provisional Patent Application Serial No. 11/304,387, which was filed by Okhonin et al. on December 15, 2005 and entitled "Bipolar Reading Technique for a Memory Cell Having an Electrically Floating Body Transistor" (U.S. Patent Application Publication No. 2006/0131650);

(7) U.S. Non-Provisional Patent Application Serial No. 11/453,594, which was filed by Okhonin et al. on June 15, 2006 and entitled "Method for Reading a Memory Cell Having an Electrically Floating Body Transistor, and Memory Cell and Array Implementing Same";

(8) U.S. Non-Provisional Patent Application Serial No. 11/509,188, which was filed by Okhonin et al. filed on August 24, 2006, and entitled "Memory Cell and Memory Cell Array Having an Electrically Floating Body Transistor, and Methods of Operating Same" (referred to above);

(9) U.S. Non-Provisional Patent Application Serial No. 11/515,667, which was filed by Bauser on September 5, 2006, and entitled "Method and Circuitry to Generate a Reference Current for Reading a Memory Cell, and Device Implementing Same";

(10) U.S. Non-Provisional Patent Application Serial No. 11/590,147, which was filed by Popov et al. on October 31, 2006, and entitled "Method and Apparatus for Varying the Programming Duration of a Floating Body Transistor, and Memory Cell, Array, and/or Device Implementing Same"; and

(11) U.S. Non-Provisional Patent Application Serial No. 11/703,429, which was filed by Okhonin et al. on February 7, 2007, and entitled "Multi-Bit Memory Cell Having Electrically Floating Body Transistor, and Method of Programming and Reading Same".

The entire contents of these eleven (11) U.S. patent applications, including, for example, the inventions, features, attributes, architectures, configurations, materials, techniques and advantages described and illustrated therein, are incorporated by reference herein. For the sake of brevity, those discussions will not be repeated; rather those discussions (text and illustrations), including the discussions relating to the memory cell, architecture, layout, structure, are incorporated by reference herein in its entirety.

Notably, the memory cells (having one or more transistors) may be controlled (for example, programmed or read) using any of the control circuitry described and illustrated in the above-referenced eleven (11) U.S. patent applications. For the sake of brevity, those discussions will not be repeated and are incorporated herein by reference. Indeed, all memory cell selection and control circuitry, and techniques for programming, reading, controlling and/or operating memory cells including transistors having electrically floating body regions, whether now known or later developed, are intended to fall within the scope of the present inventions.

For example, the data stored in or written into memory cells 12 of DRAM array/device 10 may be read using well known circuitry and techniques (whether conventional or not), including those described in the above-referenced eleven (11) U.S. patent applications. The present inventions may also employ the read circuitry and techniques described and illustrated in U.S. Patent Application Serial No. 10/840,902, which was filed by Portmann et al. on May 7, 2004, and entitled "Reference Current Generator, and Method of Programming, Adjusting and/or Operating Same" (now U.S. Patent 6,912,150).

In addition, the present inventions may employ the read operation techniques described and illustrated in U.S. Patent Application Serial No. 11/515,667, which was filed by Bauser on September 5, 2006, and entitled "Method and Circuitry to Generate a

Reference Current for Reading a Memory Cell, and Device Implementing Same". The entire contents of the U.S. Patent Application Serial No. 11/515,667, as noted above, are incorporated herein by reference.

Moreover, a sense amplifier (not illustrated in detail) may be employed to read the data stored in memory cells 12. The sense amplifier may sense the data state stored in memory cell 12 using voltage or current sensing techniques. In the context of a current sense amplifier, the current sense amplifier may compare the cell current to a reference current, for example, the current of a reference cell (not illustrated). From that comparison, it may be determined whether memory cell 12 contained a logic high (relatively more majority carriers 34 contained within body region 18) or logic low data state (relatively less majority carriers 34 contained within body region 18).

The electrically floating memory cells, transistors and/or memory array(s) may be fabricated using well known techniques and/or materials. Indeed, any fabrication technique and/or material, whether now known or later developed, may be employed to fabricate the electrically floating body memory cells, transistors and/or memory array(s). For example, the present inventions may employ silicon (whether bulk-type or SOI), germanium, silicon/germanium, gallium arsenide or any other semiconductor material in which transistors may be formed. Indeed, the electrically floating transistors, memory cells, and/or memory array(s) may employ the techniques described and illustrated in non-provisional patent application entitled "Integrated Circuit Device, and Method of Fabricating Same", which was filed on July 2, 2004, by Fazan, Serial No. 10/884,481 and/or non-provisional patent application entitled "One Transistor Memory Cell having a Strained Electrically Floating Body Region, and Method of Operating Same", which was filed on October 12, 2006, and assigned Serial No. 11/580,169, by Bassin (hereinafter collectively "Integrated Circuit Device Patent Applications"). The entire contents of the Integrated Circuit Device Patent Applications, including, for example, the inventions, features, attributes, architectures, configurations, materials, techniques and advantages described and illustrated therein, are hereby incorporated by reference herein.

Indeed, memory array 10 (including SOI memory transistors) may be integrated with SOI logic transistors, as described and illustrated in the Integrated Circuit Device Patent Applications. For example, in one embodiment, an integrated circuit device includes memory section (having, for example, PD or FD SOI memory transistors 14) and logic section (having, for example, high performance transistors, such as FinFET,

multiple gate transistors, and/or non-high performance transistors (for example, single gate transistors that do not possess the performance characteristics of high performance transistors – not illustrated)). Again, the entire contents of the Integrated Circuit Device Patent Applications, including, for example, the inventions, features, attributes, architectures, configurations, materials, techniques and advantages described and illustrated therein, are hereby incorporated by reference.

Further, the memory arrays may be comprised of N-channel, P-channel and/or both types of transistors, as well as partially depleted and/or fully depleted type transistors. For example, circuitry that is peripheral to the memory array (for example, sense amplifiers or comparators, row and column address decoders, as well as line drivers (not illustrated herein)) may include fully depleted type transistors (whether P-channel and/or N-channel type). Alternatively, such circuitry may include partially depleted type transistors (whether P-channel and/or N-channel type). There are many techniques to integrate both partially depleted and/or fully depleted type transistors on the same substrate (see, for example, U.S. Non-Provisional Patent Application Serial No. 10/487,157, which was filed by Fazan et al. on February 18, 2004 and entitled "Semiconductor Device" (U.S. Patent Application Publication No. 2004/0238890). All such techniques, whether now known or later developed, are intended to fall within the scope of the present inventions.

Notably, electrically floating body transistor 14 may be a symmetrical or non-symmetrical device. Where transistor 14 is symmetrical, the source and drain regions are essentially interchangeable. However, where transistor 14 is a non-symmetrical device, the source or drain regions of transistor 14 have different electrical, physical, doping concentration and/or doping profile characteristics. As such, the source or drain regions of a non-symmetrical device are typically not interchangeable. This notwithstanding, the drain region of the electrically floating N-channel transistor of the memory cell (whether the source and drain regions are interchangeable or not) is that region of the transistor that is connected to the bit line/sense amplifier.

There are many inventions described and illustrated herein. While certain embodiments, features, attributes and advantages of the inventions have been described and illustrated, it should be understood that many others, as well as different and/or similar embodiments, features, attributes and advantages of the present inventions, are apparent from the description and illustrations. As such, the

embodiments, features, attributes and advantages of the inventions described and illustrated herein are not exhaustive and it should be understood that such other, similar, as well as different, embodiments, features, attributes and advantages of the present inventions are within the scope of the present inventions.

For example, the plurality of memory cells 12 of the present inventions may be implemented in any memory array having, for example, a plurality of rows and columns (for example, in a matrix form). The present inventions may be implemented in any electrically floating body memory cell and memory cell array. In addition, as noted above, the present inventions may be implemented in other memory cell and memory array technologies, for example, 1T-1C (one transistor, one capacitor) and electrically floating gate memory cells.

Notably, for those unselected memory cells associated with non-enabled or unselected word lines which are not written during a programming operation, a holding condition may be applied or established to prevent, minimize or avoid disturbance of the data state of, or charge stored in the memory cells of the unselected rows of memory cells. In this regard, a voltage (for example, -1.2V) may be applied to the gates of the memory cells of the unselected rows of memory cells and a voltage (for example, 0V) may be applied to the source and drain regions of the memory cells of the unselected rows of memory cells to prevent, minimize or avoid disturbance of the data state in the memory cells of the unselected rows of memory cells during the programming or writing operation. Under these conditions, the data state of the memory cells of the unselected rows of memory cells is unaffected (or substantially unaffected) by the programming of or writing to selected memory cells of the selected rows. (See, for example, FIGURE 15).

Further, for those memory cells coupled to non-enabled or unselected word lines which are not read during a read operation, a holding condition may be applied or established to prevent, minimize or avoid disturbance of the data state in the memory cells of the unselected rows of memory cells of the array. In this regard, a voltage (for example, -1.2V) may be applied to the gates of the unselected memory cells and a voltage (for example, 0V) may be applied to the source regions of the memory cells of the unselected rows of memory cells to prevent, minimize or avoid disturbance of the data state in the unselected memory cells during the read operation. Under these conditions, the states of the memory cells of the unselected rows of memory cells are

unaffected (or it is substantially unaffected) during the reading of selected memory cells of the selected rows of memory cells. (See, for example, FIGURE 16).

As noted above, the word length of the array may be one time programmable (for example, programmed during test, design or at manufacture) or more than one time programmable (for example, during test, start-up/power-up, during an initialization sequence and/or during operation (in situ)). For example, in one embodiment, data which is representative of the word length may be stored in on-chip word length selection circuitry (for example, in fuses or anti-fuses, or DRAM, SRAM, ROM, PROM, EPROM, EEPROM cells, latches, and/or registers which is/are resident on or integrated in the device). The on-chip word length selection circuitry may be disposed, in whole or in part, in the logic portion and/or peripheral portion of the integrated circuit device. (See, for example, FIGURES 20A-20C).

In addition thereto or in lieu thereof, the word length selection circuitry may be located, in whole or in part, on-chip (for example, in fuses or anti-fuses, or DRAM, SRAM, ROM, PROM, EPROM, EEPROM cells, latches, and/or registers) and the circuitry that programs such word length selection circuitry may be located off-chip. In this regard, with reference to FIGURES 21A-21C, word length selection circuitry (which, in this embodiment, is on-chip) may be programmed via circuitry located or disposed in external controller/processor 36 (for example, memory controller, microprocessor and/or graphics processor). The external controller/processor 36 may be implemented on module 100 (see, for example, FIGURE 21A), in system 1000 having a distributed bus architecture (see, for example, FIGURE 21B), and/or in system 1000 having a point-point architecture (see, for example, FIGURE 21C). In each embodiment, controller/processor 36 may provide information to memory device 50 which, in response, controls the word length of the array within memory device 50.

For example, as mentioned above, the illustrated/exemplary voltage levels to implement the read and write operations are merely exemplary. The indicated voltage levels may be relative or absolute. Alternatively, the voltages indicated may be relative in that each voltage level, for example, may be increased or decreased by a given voltage amount (for example, each voltage may be increased or decreased by 0.1, 0.15, 0.25, 0.5, 1 volt, (or more)) whether one or more of the voltages (for example, the source, drain or gate voltages) become or are positive and negative.

Moreover, the above embodiments of the inventions are merely exemplary. They are not intended to be exhaustive or to limit the inventions to the precise forms, techniques, materials and/or configurations disclosed. Many modifications and variations are possible in light of this disclosure. It is to be understood that other embodiments may be utilized and operational changes may be made without departing from the scope of the present inventions. As such, the scope of the inventions is not limited solely to the description above because the description of the above embodiments has been presented for the purposes of illustration and description.

It should be noted that the term "circuit" may mean, among other things, a single component or a multiplicity of components (whether in integrated circuit form or otherwise), which are active and/or passive, and which are coupled together to provide or perform a desired operation. The term "circuitry" may mean, among other things, a circuit (whether integrated or otherwise), or a group of circuits (whether integrated or otherwise).

The term "inhibit" may mean, among other things, prevent, thwart, inhibit and/or disable. The phrase "to sense" or similar, means, for example, to measure, to sample, to sense, to inspect, to detect, to monitor and/or to capture.

What is claimed is:

1. An integrated circuit device comprising:

a memory cell array including:

a plurality of word lines;

a plurality of source lines;

a plurality of bit lines; and

a plurality of memory cells arranged in a matrix of rows and columns, wherein each memory cell includes an electrically floating body transistor, wherein the electrically floating body transistor includes:

a first region coupled to an associated source line;

a second region coupled to an associated bit line;

a body region disposed between the first region and the second region, wherein the body region is electrically floating;

a gate disposed over the body region and coupled to an associated word line; and

wherein each memory cell includes a plurality of data states, including:

(i) a first data state which is representative of a first charge in the body region of the electrically floating body transistor; and

(ii) a second data state which is representative of a second charge in the body region of the electrically floating body transistor;

first circuitry, coupled to each memory cell of a first row of memory cells, to concurrently apply:

(i) write control signals to a first group of memory cells of the first row of memory cells to write one of the plurality of data states therein, and

(ii) write de-select control signals to a second group of memory cells of the first row of memory cells to inhibit writing of write one of the plurality of data states therein.

2. The integrated circuit device of claim 1 wherein the number of memory cells of the first group of memory cells corresponds to a word length of the memory cell array.

3. The integrated circuit device of claim 2 further including word length selection circuitry to store data which is representative of the word length.

4. The integrated circuit device of claim 1 wherein the write de-select control signals include: (i) a first temporally changing signal applied to the gate of each memory cell of the second group of memory cells, (ii) a second temporally changing signal applied to the first region of each memory cell of the second group of memory cells, and (iii) a third temporally changing signal applied to the second region of each memory cell of the second group of memory cells.

5. The integrated circuit device of claim 4 wherein the write control signals include: (i) the first temporally changing signal applied to the gate of each memory cell of the first group of memory cells, (ii) the second temporally changing signal applied to the first region of each memory cell of the first group of memory cells, and (iii) a fourth temporally changing signal applied to the second region of each memory cell of the first group of memory cells.

6. The integrated circuit device of claim 1 wherein the write de-select control signals include: (i) a first temporally changing signal applied to the gate of each memory cell of the second group of memory cells, (ii) a second temporally changing signal applied to the first region of each memory cell of the second group of memory cells, and (iii) a third signal having a substantially constant voltage amplitude applied to the second region of each memory cell of the second group of memory cells.

7. The integrated circuit device of claim 6 wherein the write control signals include: (i) the first temporally changing signal applied to the gate of each memory cell of the first group of memory cells, (ii) the second temporally changing signal applied to the first region of each memory cell of the first group of memory cells, and (iii) a fourth temporally changing signal applied to the second region of each memory cell of the first group of memory cells.

8. The integrated circuit device of claim 1 further including second circuitry, coupled to each memory cell of the first row of memory cells, to concurrently apply: (i) read control signals to the first group of memory cells of the first row of memory cells to read the data state of each memory cell of the first group of memory cells, and (ii) read de-select control signals to the second group of memory cells of the first row of memory cells to inhibit reading the data state of each memory cell of the second group of memory cells.

9. The integrated circuit device of claim 8 wherein the read control signals include a signal applied to the gate, a signal applied to the first region, and a signal applied to the second region of the electrically floating body transistor of each memory cell of the first group of memory cells to cause, force and/or induce a read bipolar transistor current which is representative of the data state of each memory cell of the first group of memory cells of the first row of memory cells.

10. The integrated circuit device of claim 9 wherein the second circuitry determines the data state of the memory cell substantially based on the read bipolar transistor current.

11. The integrated circuit device of claim 9 wherein the second circuitry includes a plurality of sense amplifiers.

12. The integrated circuit device of claim 1 wherein the write control signals include control signals to write the first data state and wherein, in response to the control signals to write the first data state into a predetermined memory cell of the first row of memory cells, the electrically floating body transistor of the predetermined memory cell of the first row of memory cells generates a bipolar transistor current which substantially provides the first charge in the body region of the electrically floating body transistor of the predetermined memory cell of the first row of memory cells.

13. The integrated circuit device of claim 1 wherein the each memory cell includes a third data state which is representative of a third charge in the body region of the electrically floating body transistor.

14. An integrated circuit device comprising;  
a semiconductor memory array including:

- a plurality of word lines;
- a plurality of source lines;
- a plurality of bit lines; and

a plurality of memory cells arranged in a matrix of rows and columns, wherein each memory cell includes an electrically floating body transistor, wherein the electrically floating body transistor includes:

- a first region coupled to an associated source line;
- a second region coupled to an associated bit line;
- a body region disposed between the first region and the second region, wherein the body region is electrically floating;
- a gate disposed over the body region and coupled to an associated word line; and

wherein each memory cell includes at least two data states, including:

- (i) a first data state which is representative of a first charge in the body region of the associated electrically floating body transistor; and
- (iii) a second data state which is representative of a second charge in the body region of the associated electrically floating body transistor; and

circuitry, coupled to each memory cell of the first row of memory cells, to substantially concurrently apply:

- (i) read control signals to a first group of memory cells of the first row of memory cells to read the data state of each memory cell of the first group of memory cells, and
- (ii) read de-select control signals to a second group of memory cells of the first row of memory cells to inhibit reading the data state of each memory cell of the second group of memory cells.

15. The integrated circuit device of claim 14 wherein the read control signals include a signal applied to the gate, a signal applied to the first region, and a signal applied to the second region of the electrically floating body transistor of each memory cell of the first group of memory cells to cause, force and/or induce a read bipolar transistor current which is representative of the data state of each memory cell of the first group of memory cells of the first row of memory cells.

16. The integrated circuit device of claim 14 wherein the circuitry determines the data state of the memory cell substantially based on the read bipolar transistor current.

17. The integrated circuit device of claim 14 wherein the circuitry includes a plurality of sense amplifiers.

18. The integrated circuit device of claim 14 further including write circuitry, coupled to each memory cell of a first row of memory cells, to concurrently apply:

(i) write control signals to a first group of memory cells of the first row of memory cells to write one of the plurality of data states therein, and

(ii) write de-select control signals to a second group of memory cells of the first row of memory cells to inhibit the writing of write one of the plurality of data states therein; and

wherein the write control signals include control signals to write the first data state and wherein, in response to the control signals to write the first data state into a predetermined memory cell of the first row of memory cells, the electrically floating body transistor of the predetermined memory cell of the first row of memory cells generates a bipolar transistor current which substantially provides the first charge in the body region of the electrically floating body transistor of the predetermined memory cell of the first row of memory cells.

19. The integrated circuit device of claim 14 wherein the number of memory cells of the first group of memory cells corresponds to a word length of the memory cell array.

20. The integrated circuit device of claim 19 further including word length selection circuitry to store data which is representative of the word length.

21. An integrated circuit device comprising;

a semiconductor memory array, disposed in or on a semiconductor region or layer which resides on or above an insulating region or layer of a substrate, the semiconductor memory array, comprising:

a plurality of word lines;

a plurality of source lines;

a plurality of bit lines; and

a plurality of dynamic random access memory cells disposed in or on the semiconductor region or layer and arranged in a matrix of rows and columns, each dynamic random access memory cell includes at least one transistor having:

a first region coupled to an associated source line;

a second region coupled to an associated bit line;

a body region disposed between the first region and the second region, wherein the body region is electrically floating;

a gate disposed over the body region and coupled to an associated word line; and

wherein each memory cell includes at least two data states, including:

(i) a first data state which is representative of a first charge in the body region of the associated electrically floating body transistor; and

(ii) a second data state which is representative of a second charge in the body region of the associated electrically floating body transistor;

first circuitry, coupled to each memory cell of a first row of memory cells, to concurrently apply:

(i) write control signals to a first group of memory cells of the first row of memory cells to write one of the plurality of data states therein, and

(ii) write de-select control signals to a second group of memory cells of the first row of memory cells to inhibit the writing of write one of the plurality of data states therein; and

second circuitry, coupled to each memory cell of the first row of memory cells, to substantially concurrently apply:

(i) read control signals to the first group of memory cells of the first row of memory cells to read the data state of each memory cell of the first group of memory cells, and

(ii) read de-select control signals to the second group of memory cells of the first row of memory cells to inhibit reading the data state of each memory cell of the second group of memory cells.

22. The integrated circuit device of claim 21 wherein the read control signals include a signal applied to the gate, a signal applied to the first region, and a signal applied to the second region of the electrically floating body transistor of each memory cell of the first group of memory cells to cause, force and/or induce a read bipolar transistor current which is representative of the data state of each memory cell of the first group of memory cells of the first row of memory cells.

23. The integrated circuit device of claim 21 wherein the second circuitry determines the data state of the memory cell substantially based on the read bipolar transistor current.

24. The integrated circuit device of claim 21 wherein the second circuitry includes a plurality of sense amplifiers.

25. The integrated circuit device of claim 21 wherein the write control signals include control signals to write the first data state and wherein, in response to the control signals to write the first data state into a predetermined memory cell of the first row of memory cells, the electrically floating body transistor of the predetermined memory cell of the first row of memory cells generates a bipolar transistor current which substantially provides the first charge in the body region of the electrically floating body transistor of the predetermined memory cell of the first row of memory cells.

26. The integrated circuit device of claim 21 wherein the each memory cell includes a third data state which is representative of a third charge in the body region of the electrically floating body transistor.

27. The integrated circuit device of claim 21 wherein the number of memory cells of the first group of memory cells corresponds to a word length of the memory cell array.

28. The integrated circuit device of claim 27 further including word length selection circuitry to store data which is representative of the word length.

1/26

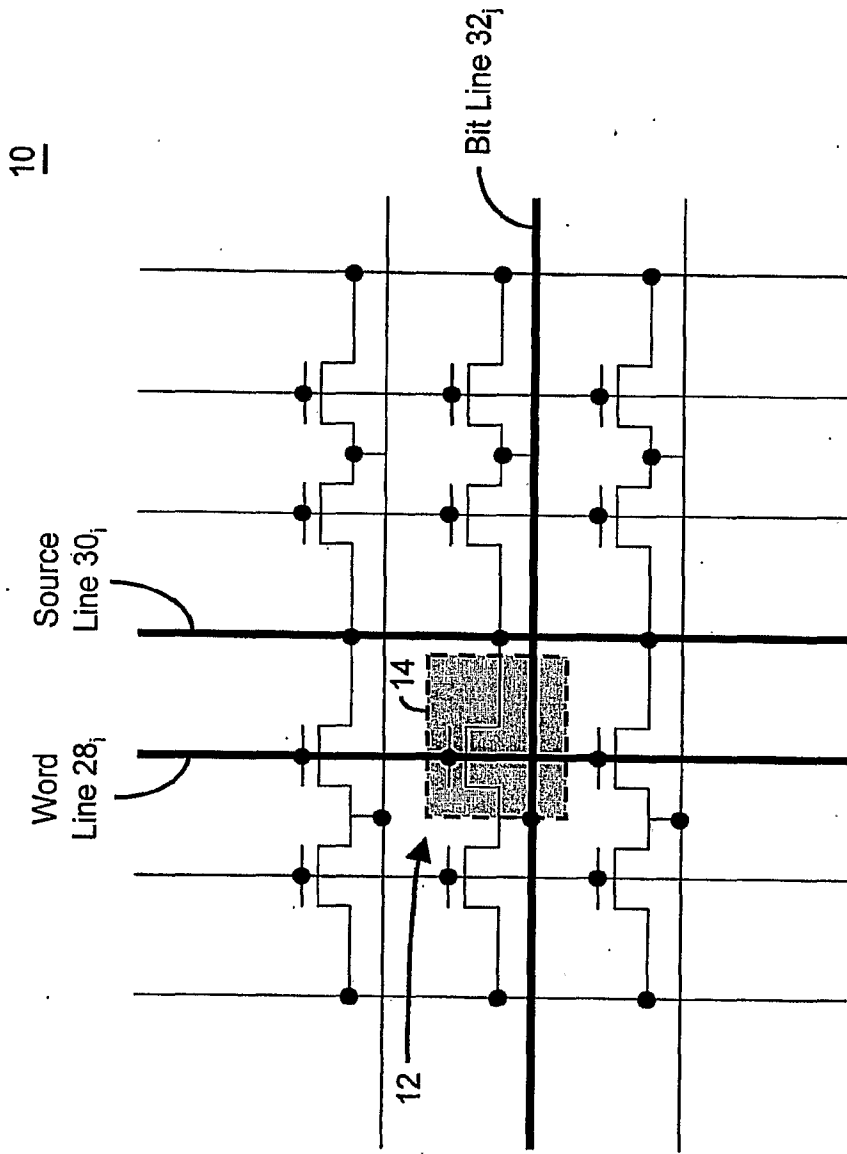
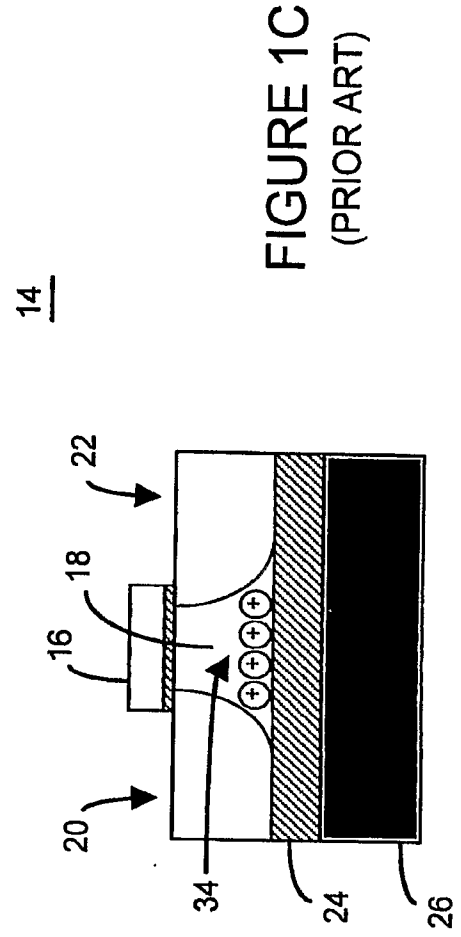
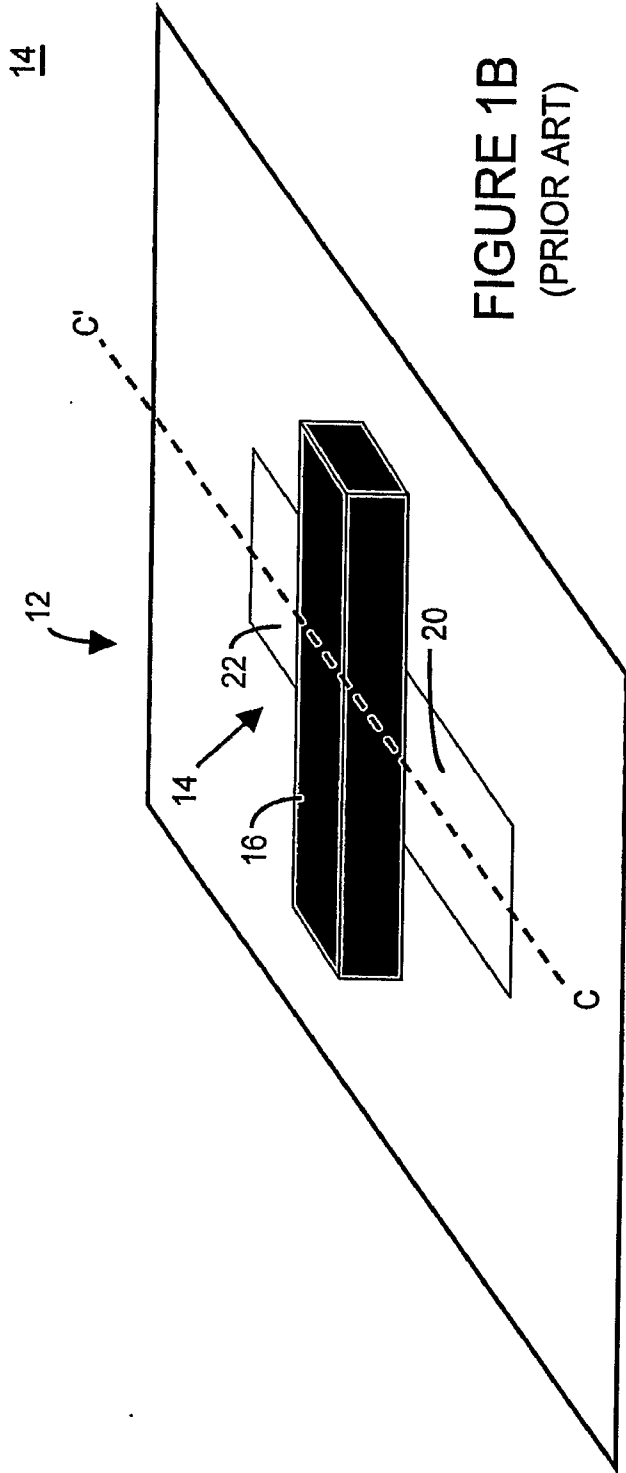

FIGURE 1A  
(PRIOR ART)



14

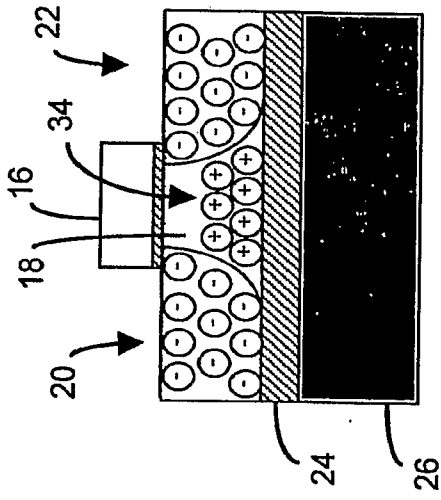

FIGURE 2A  
(PRIOR ART)

14

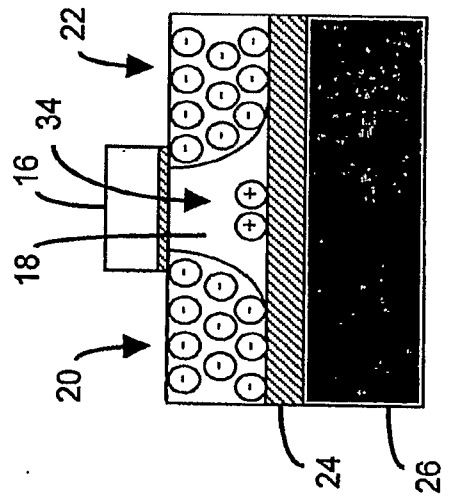
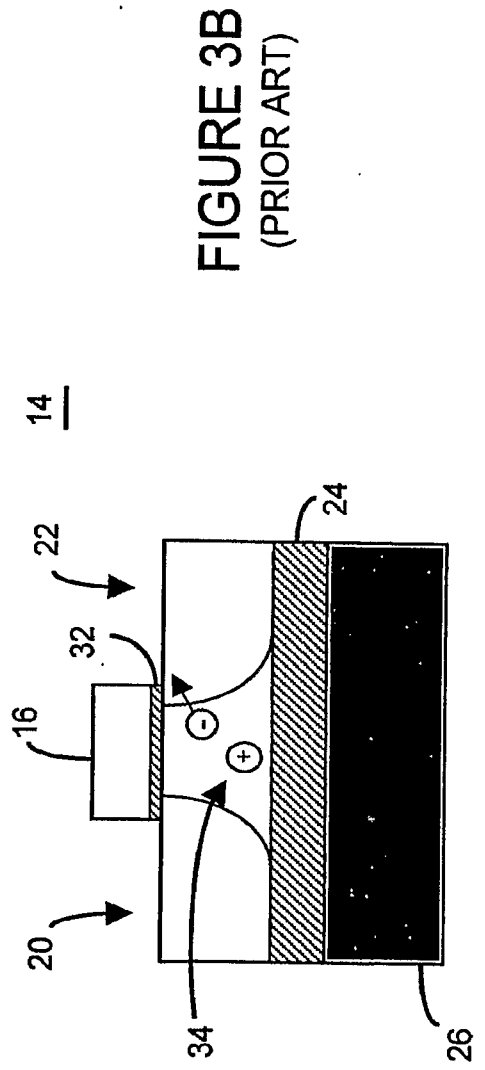
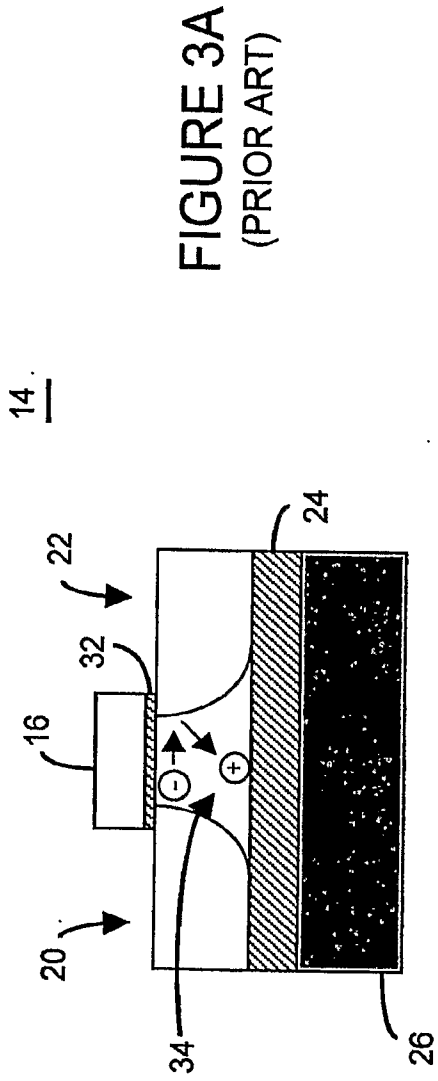

FIGURE 2B  
(PRIOR ART)



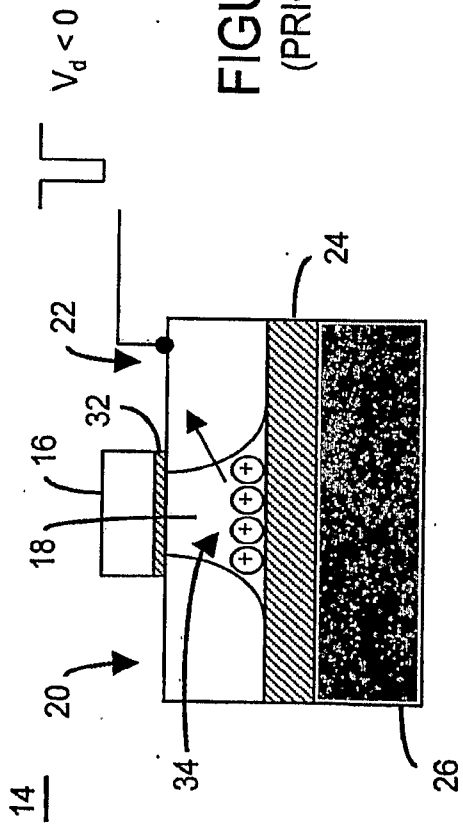

FIGURE 4A  
(PRIOR ART)

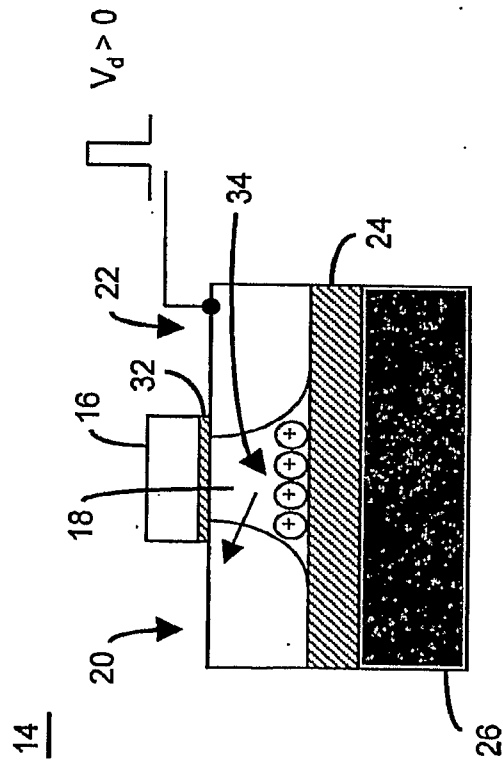

FIGURE 4B  
(PRIOR ART)

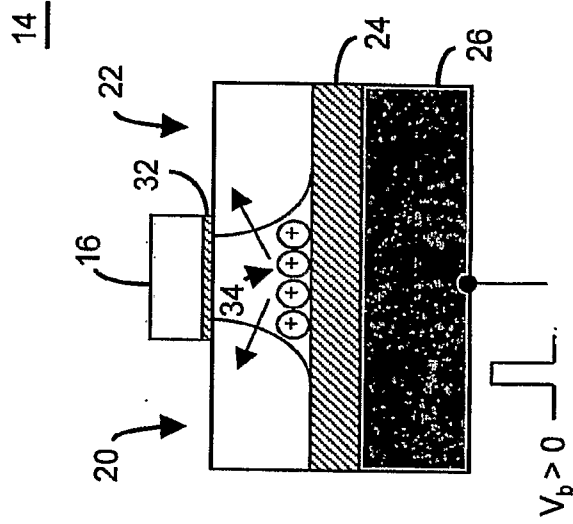

FIGURE 4C  
(PRIOR ART)

6/26

14

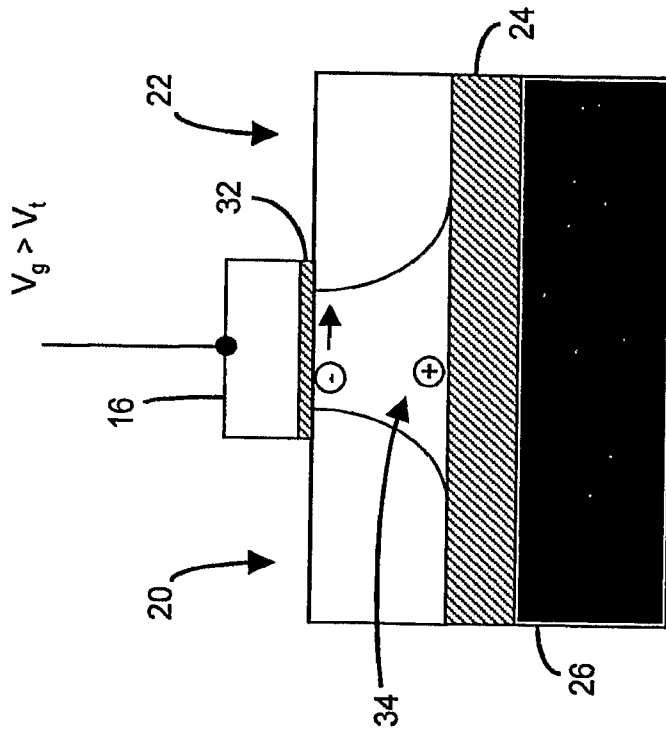

FIGURE 5  
(PRIOR ART)

7/26

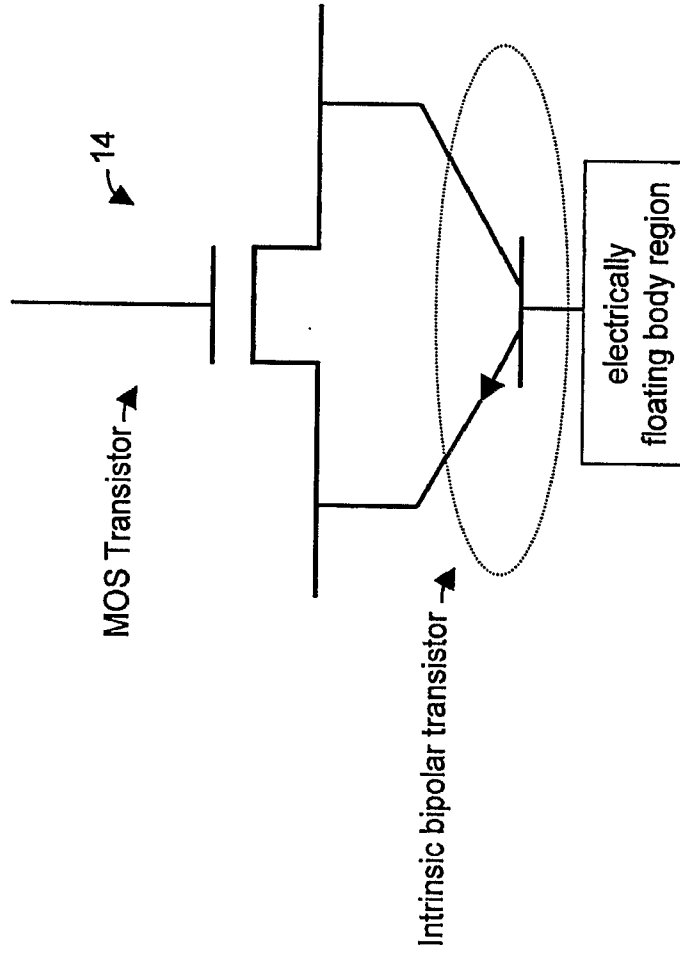

FIGURE 6

8/26

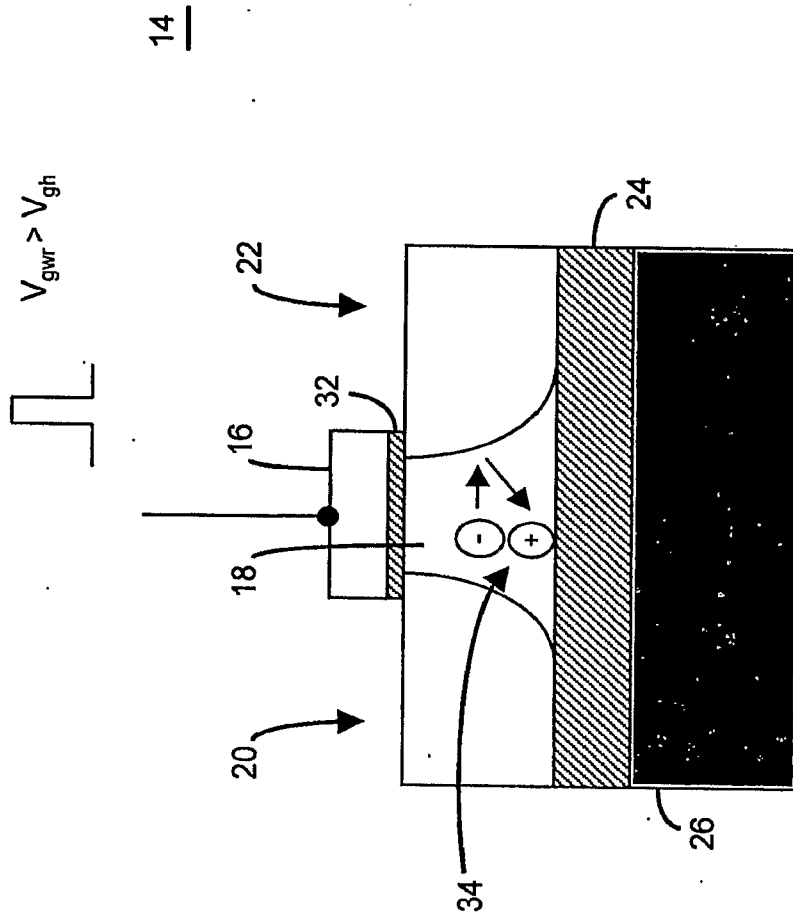

FIGURE 7

9/26

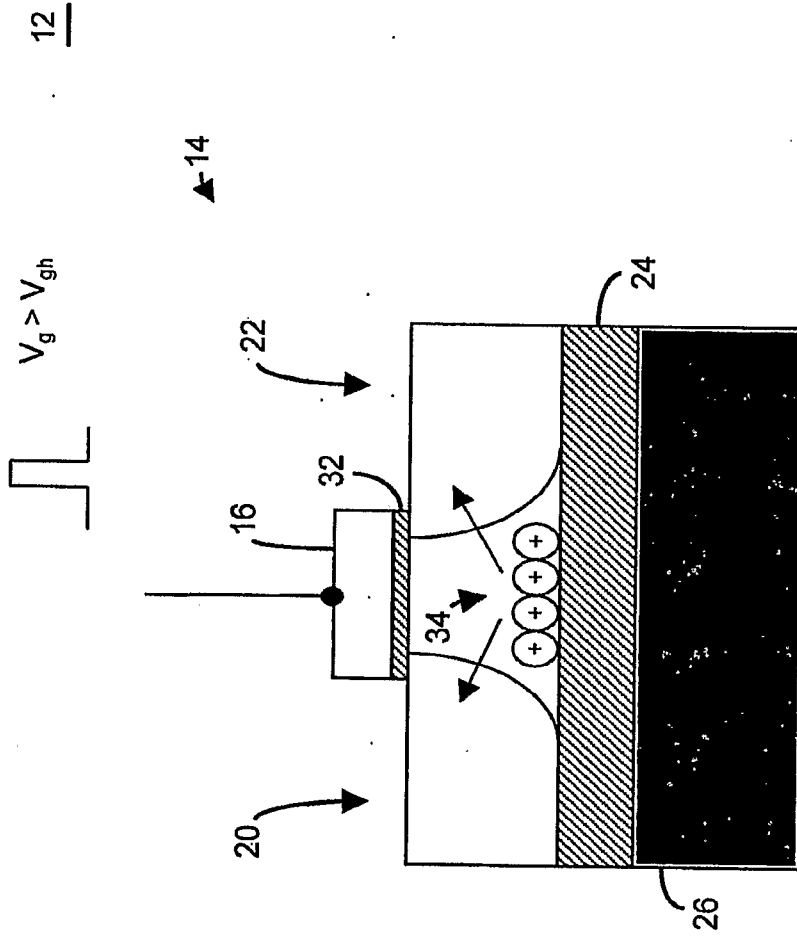

FIGURE 8

10/26

12

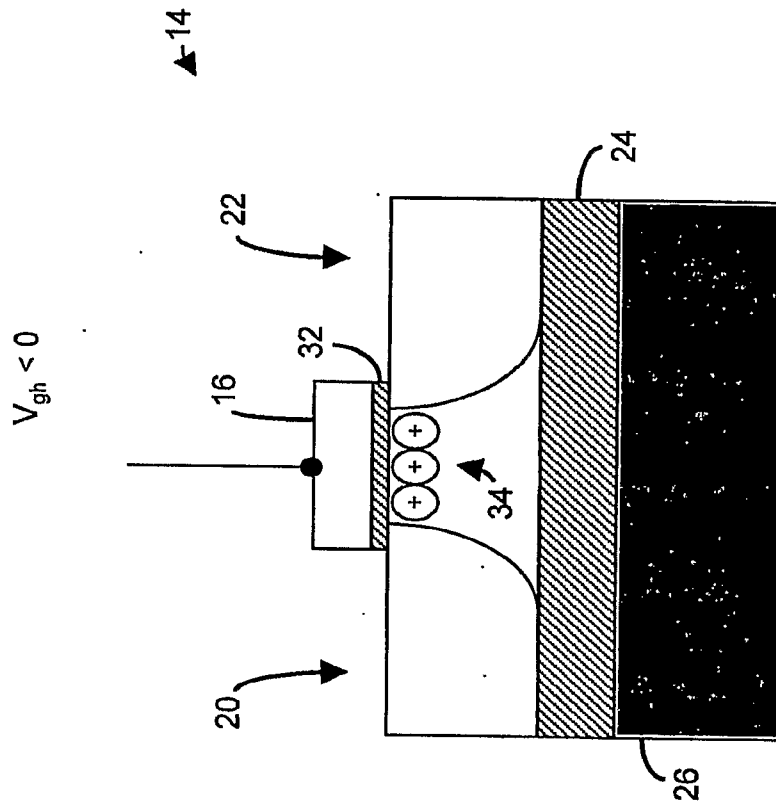

FIGURE 9



12/26

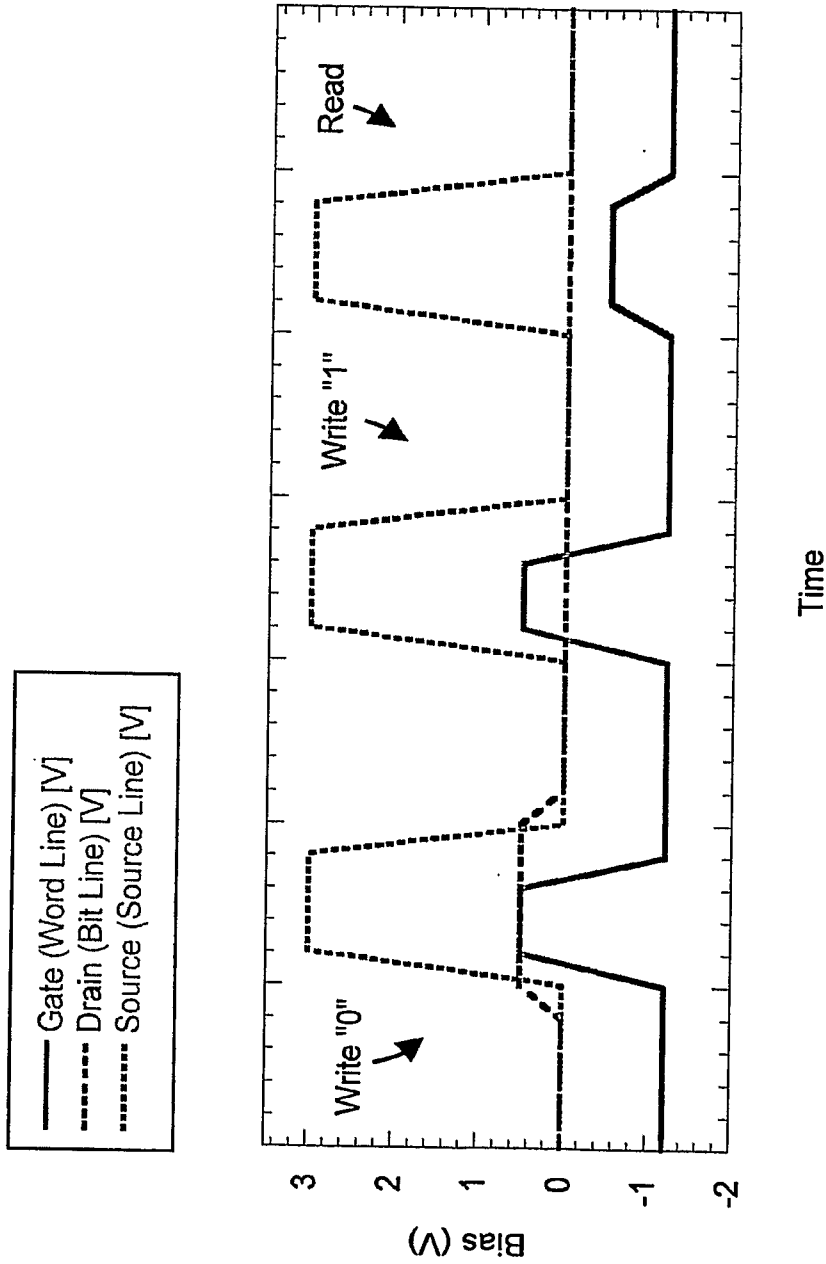

FIGURE 11

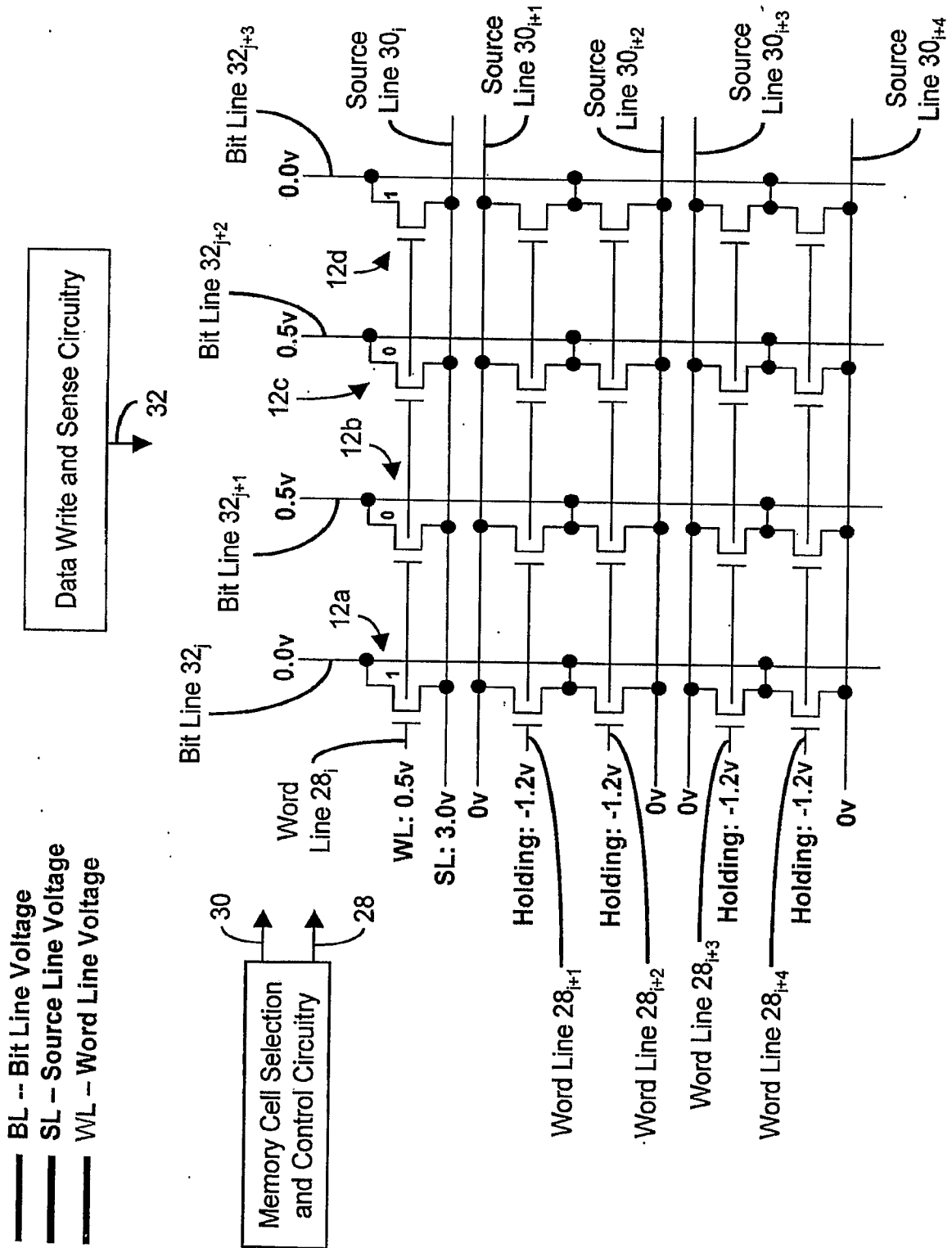

FIGURE 12

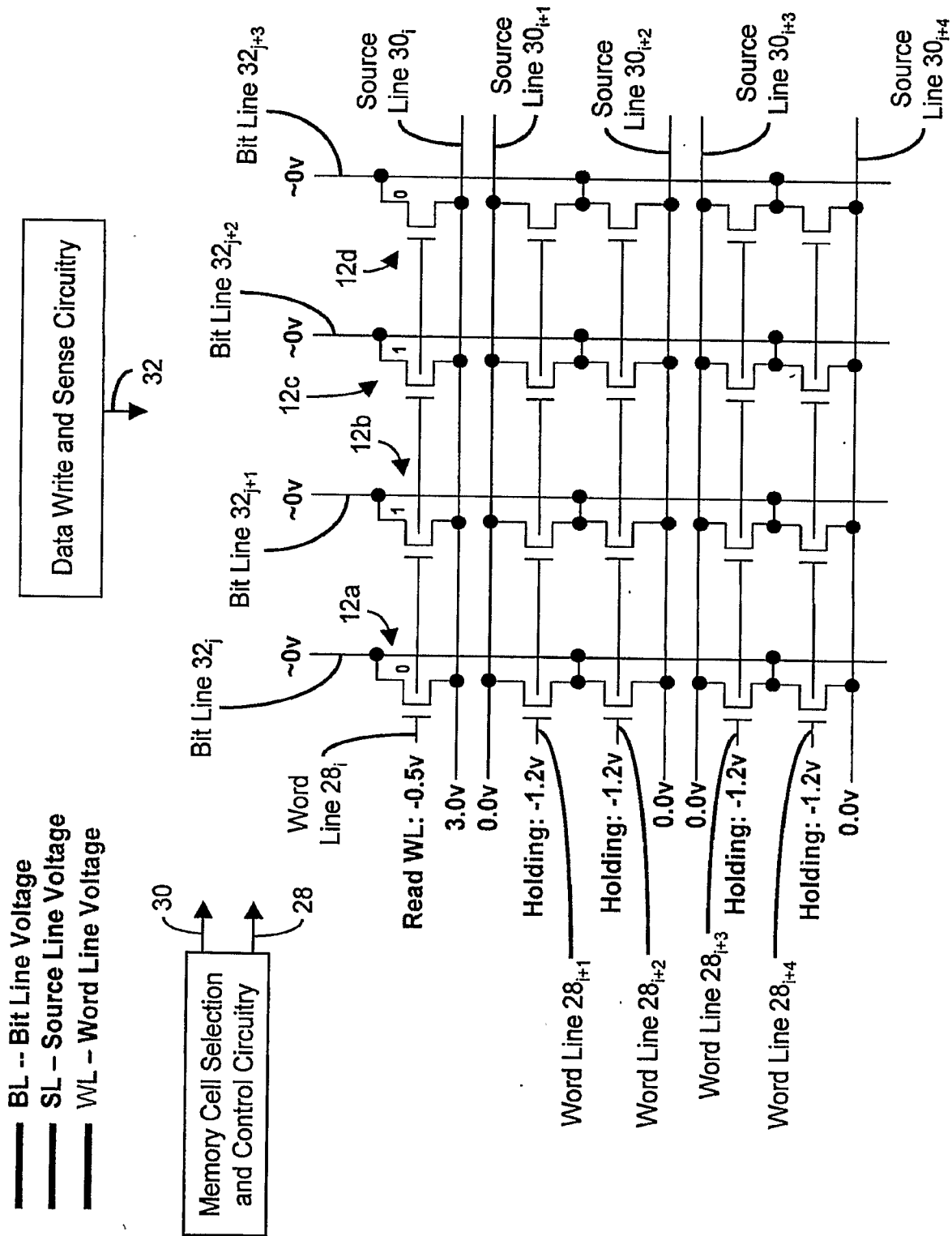

FIGURE 13

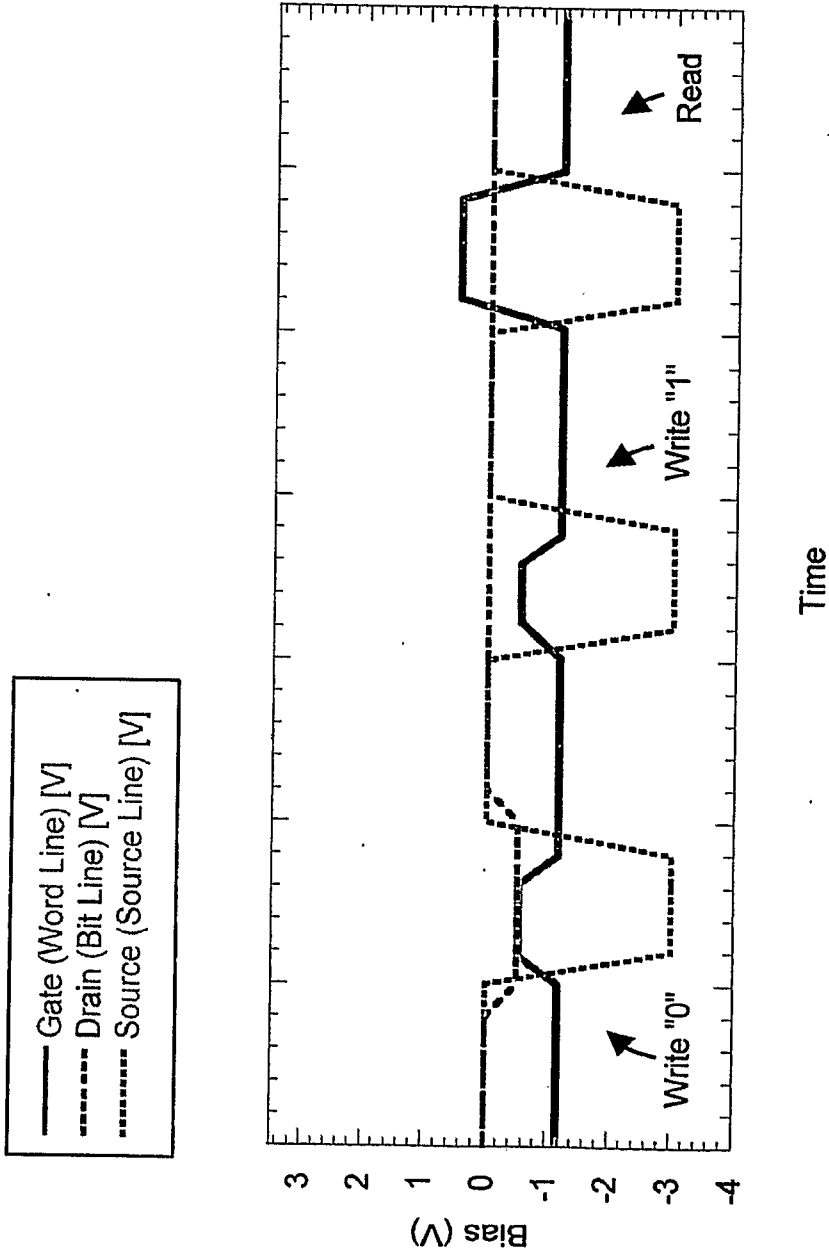

FIGURE 14

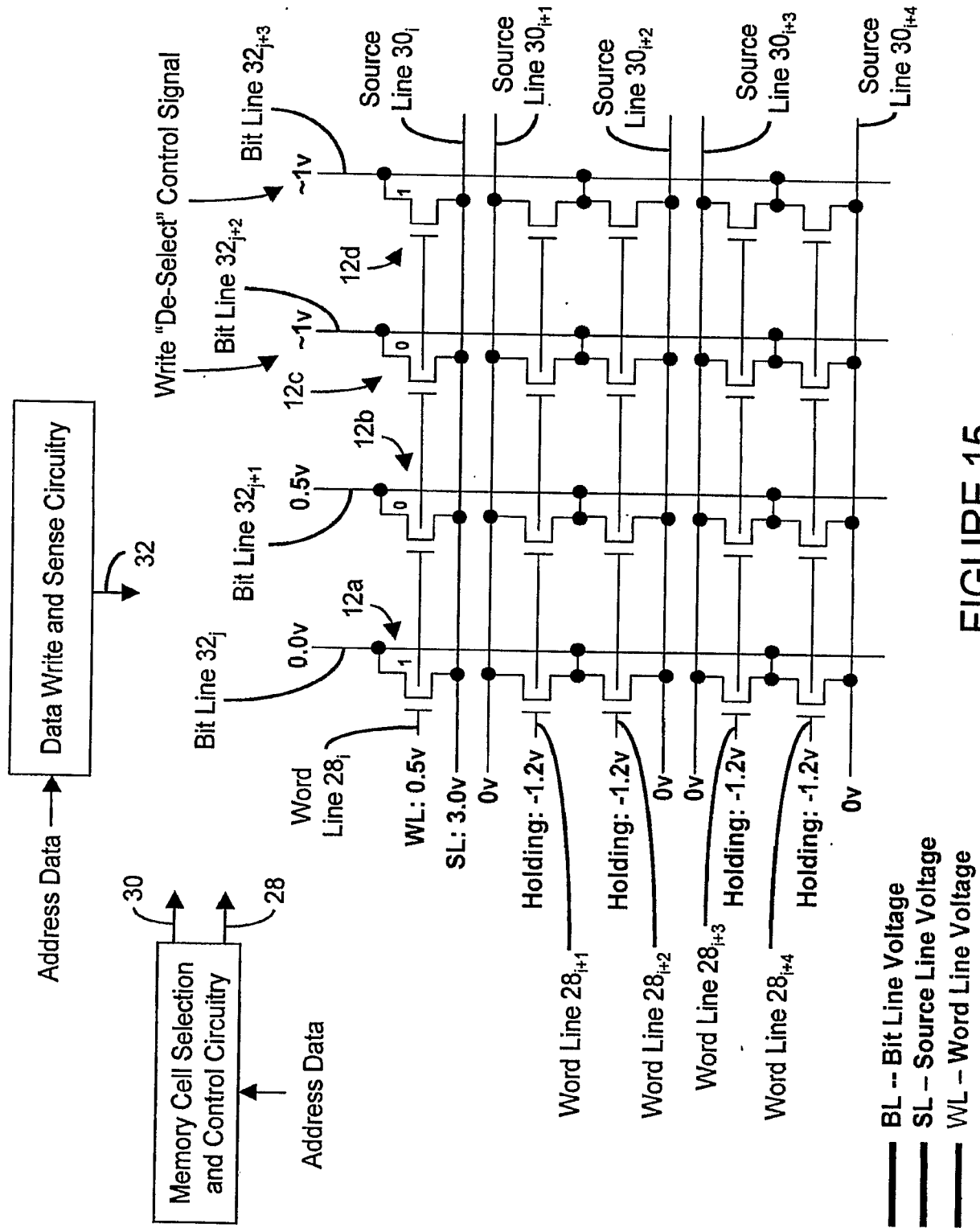

FIGURE 15

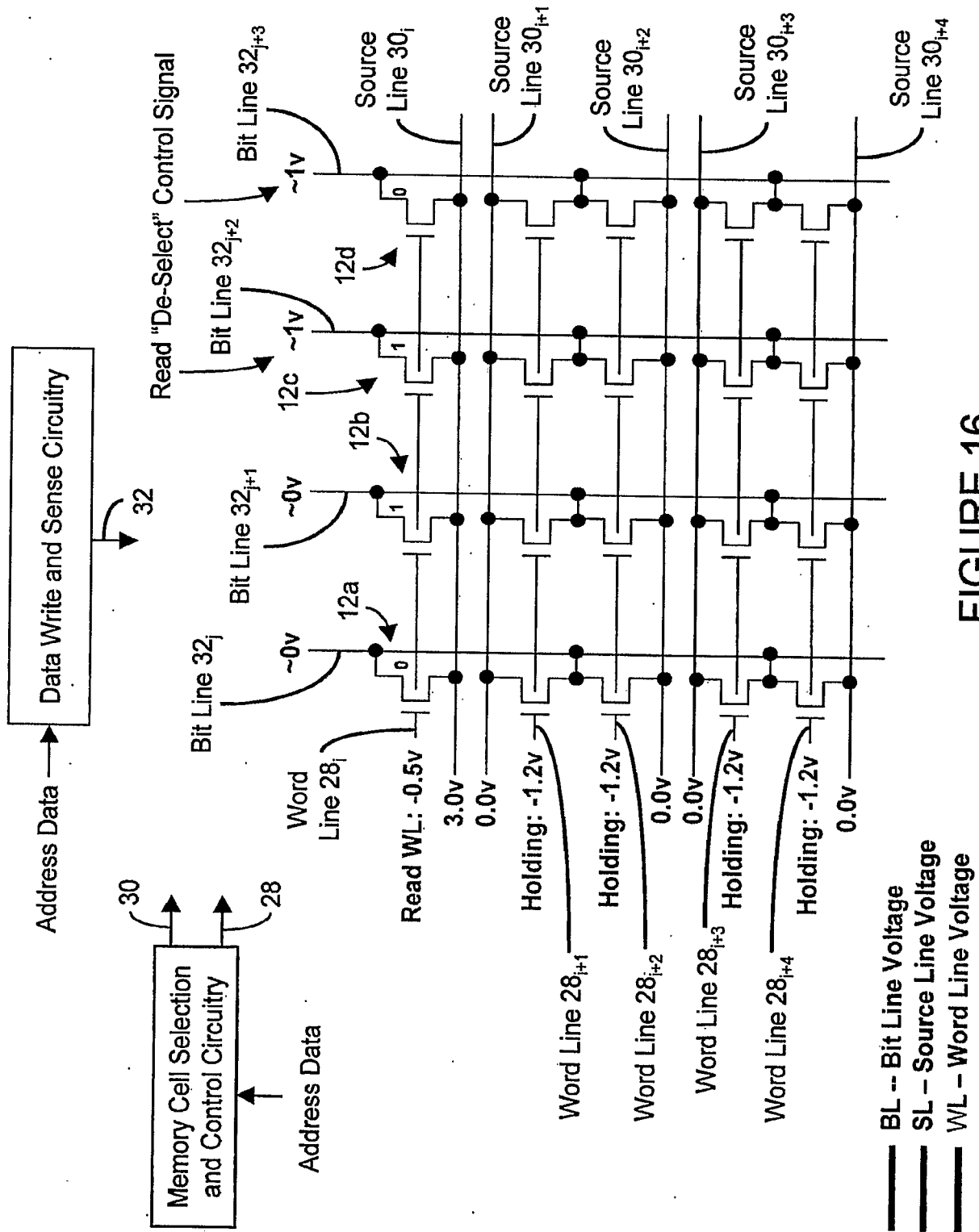

FIGURE 16

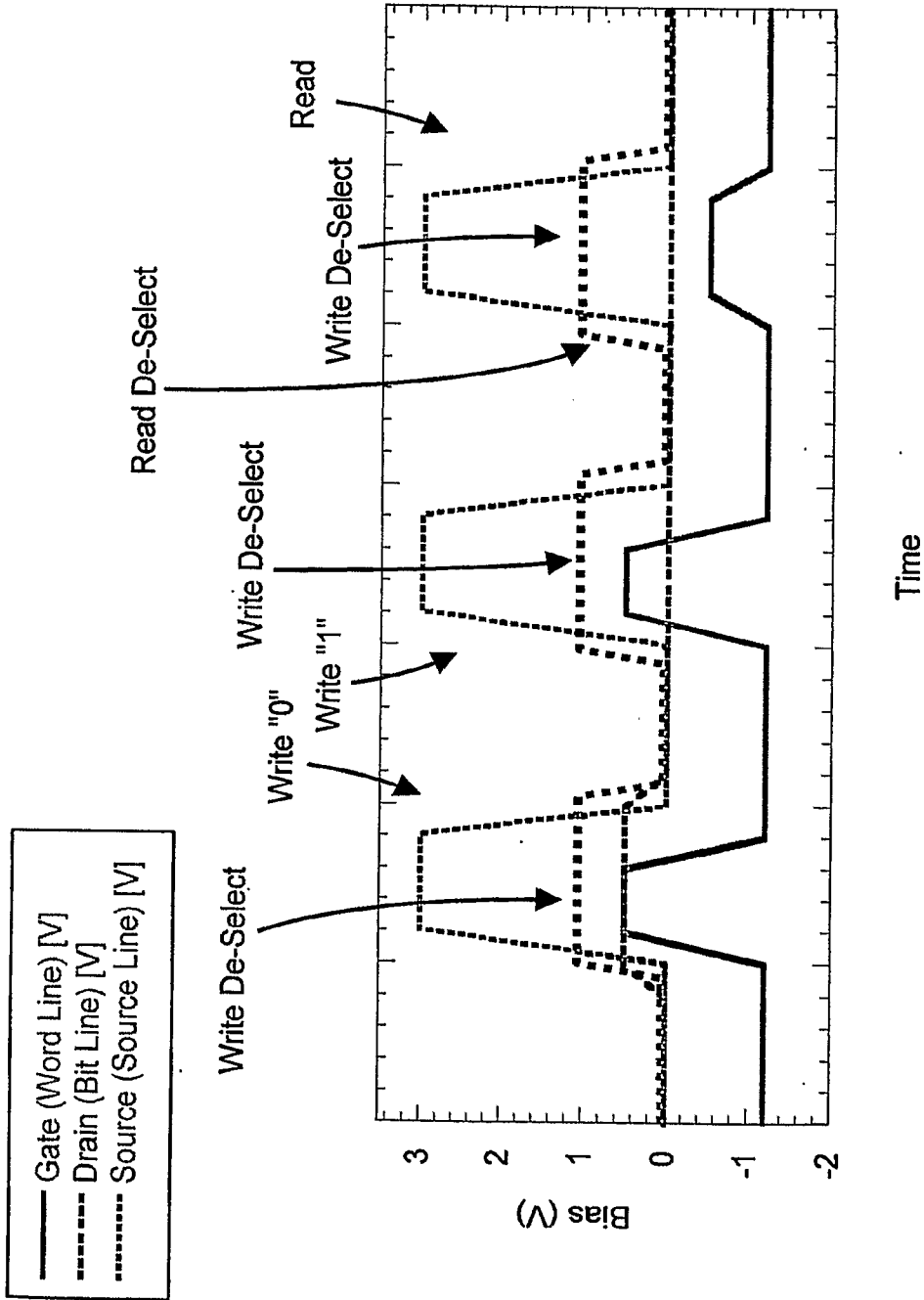

FIGURE 17

19/26

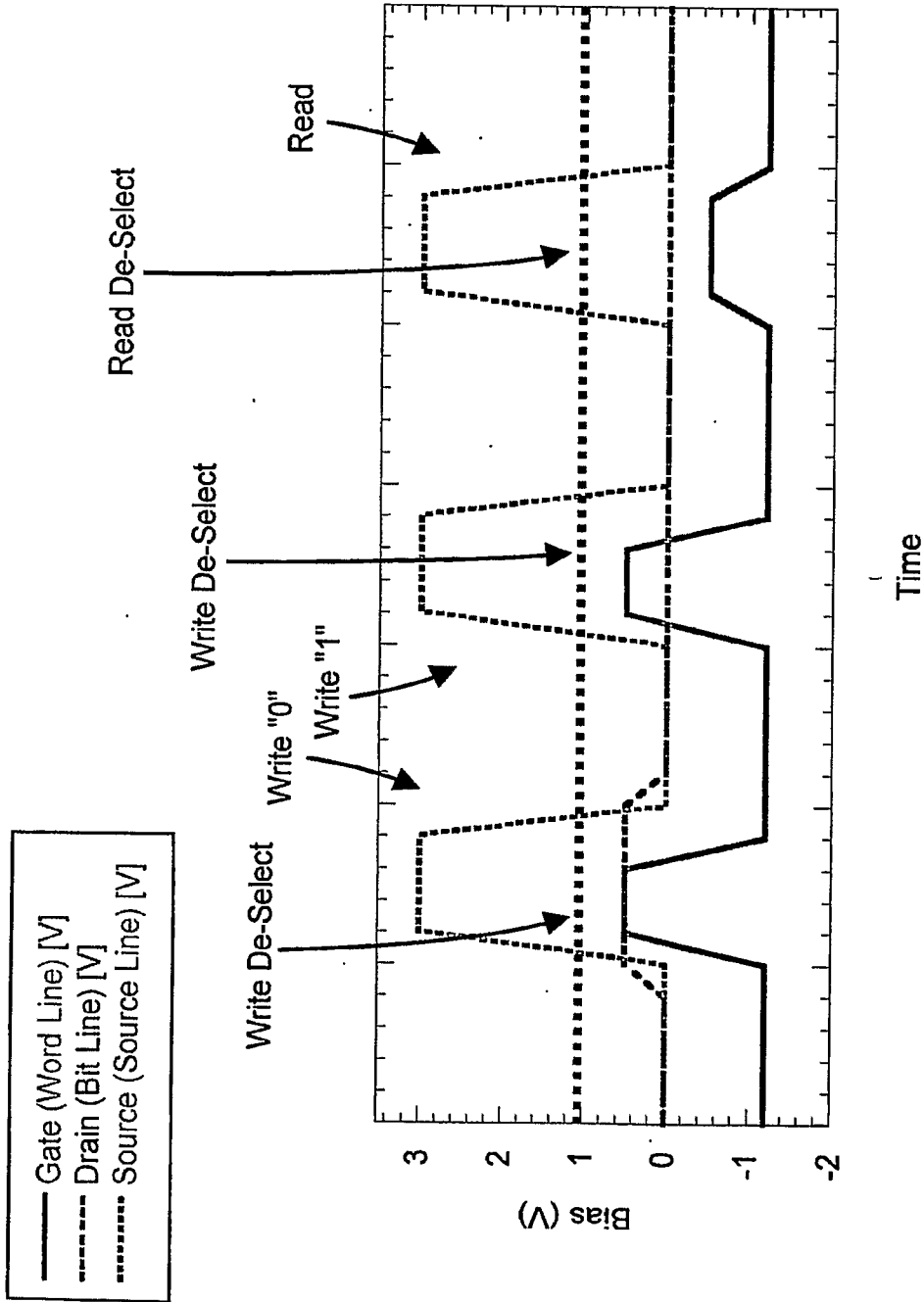

FIGURE 18

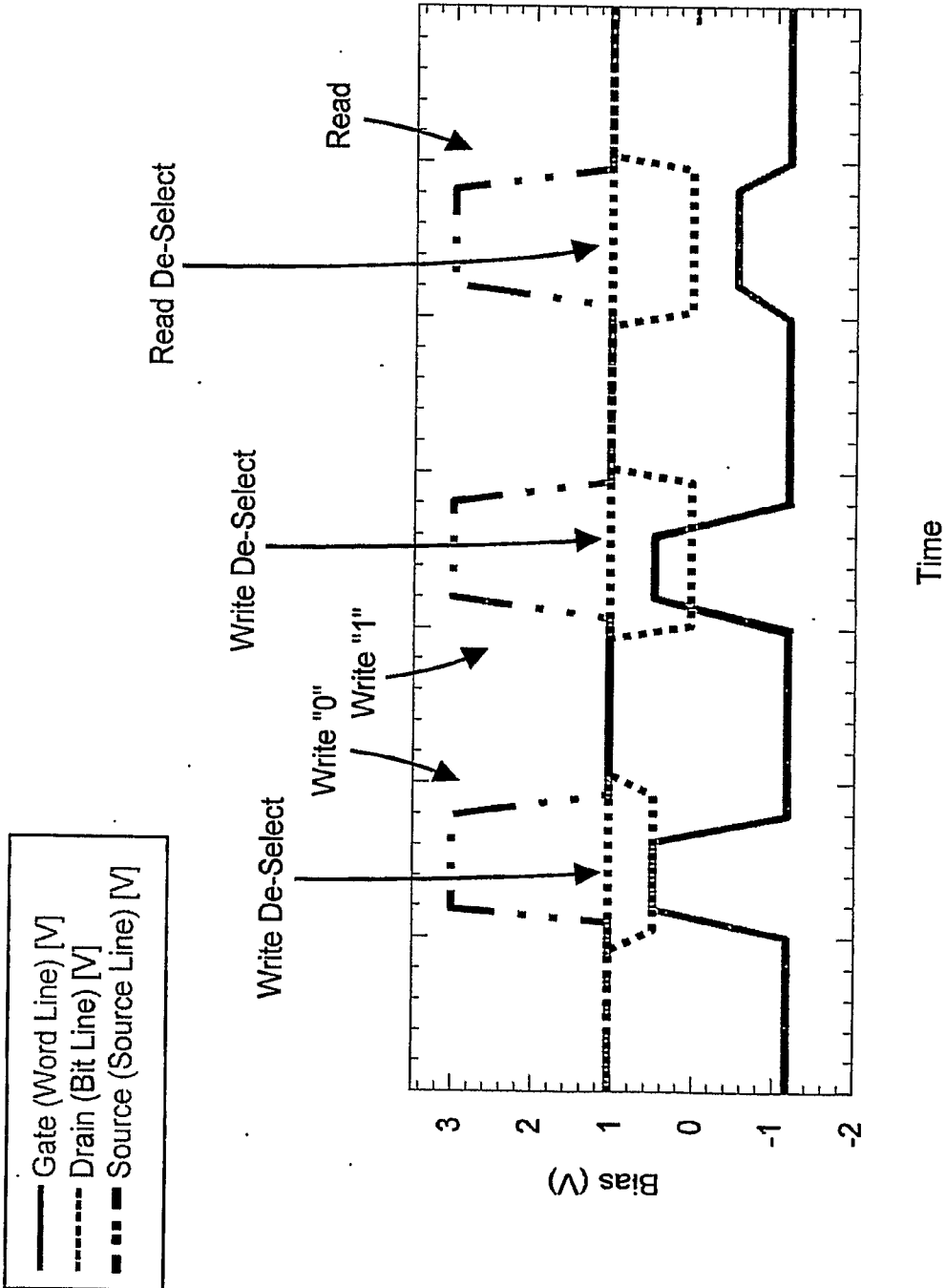

FIGURE 19

FIGURE 20A

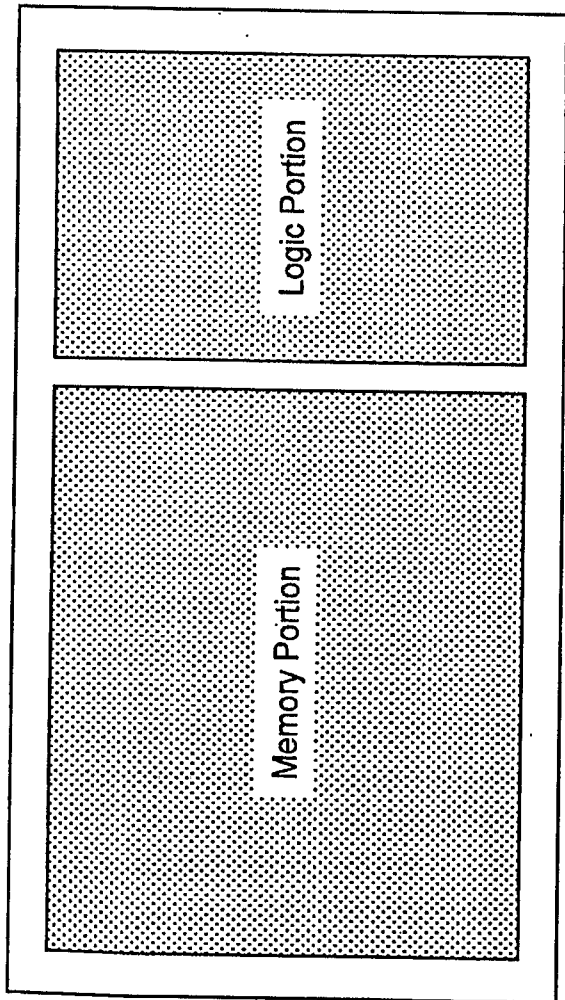
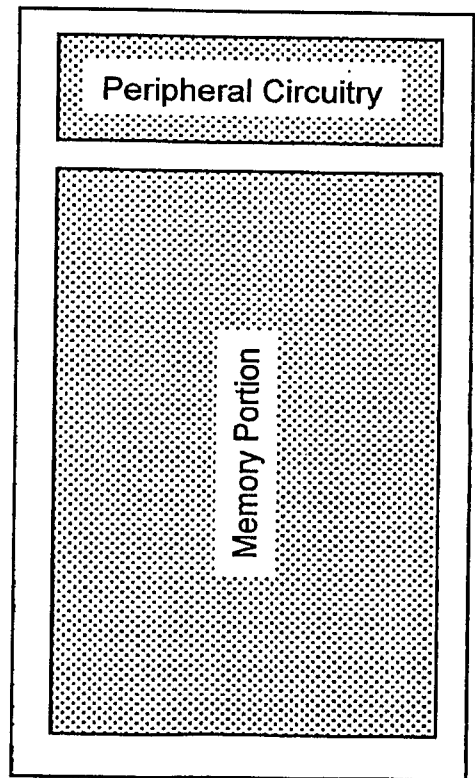

FIGURE 20B



22/26

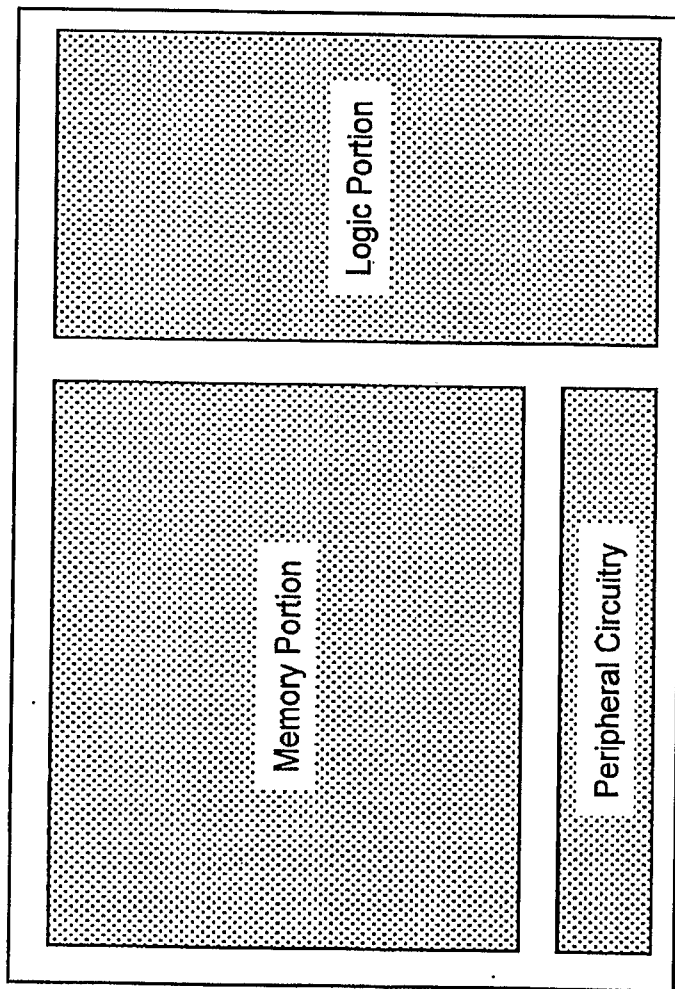

FIGURE 20C

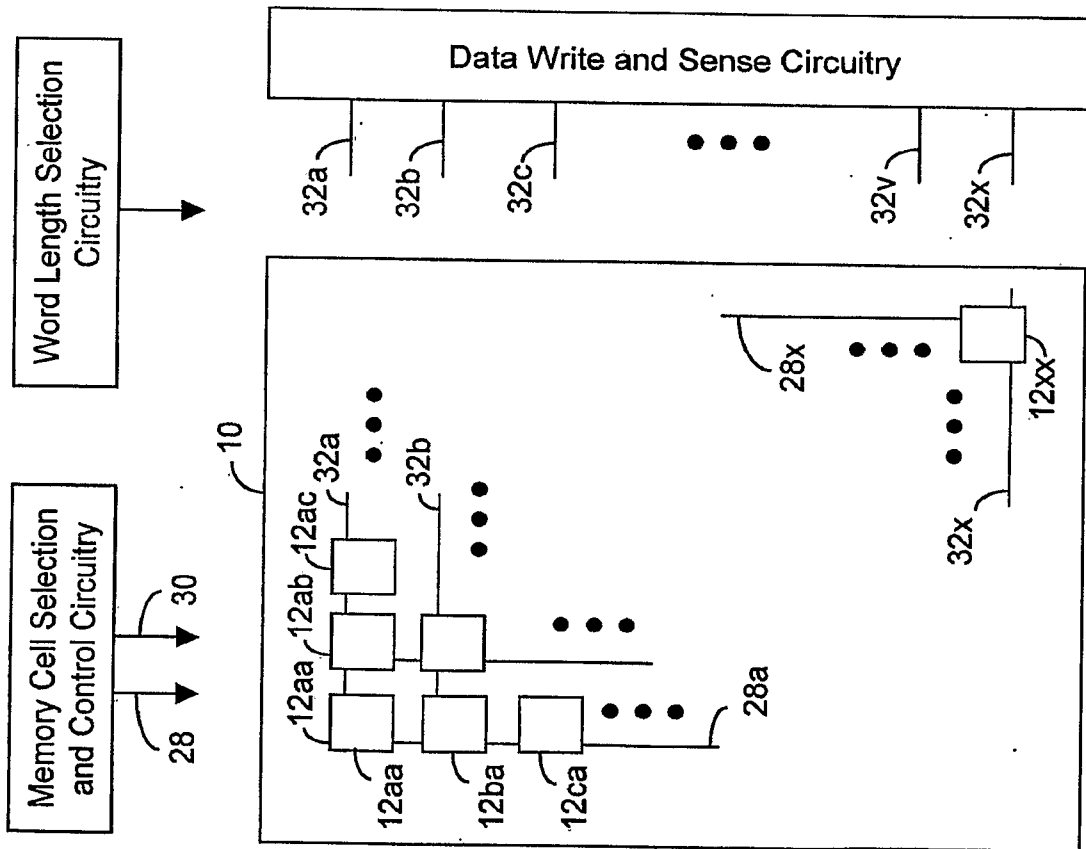

FIGURE 20D

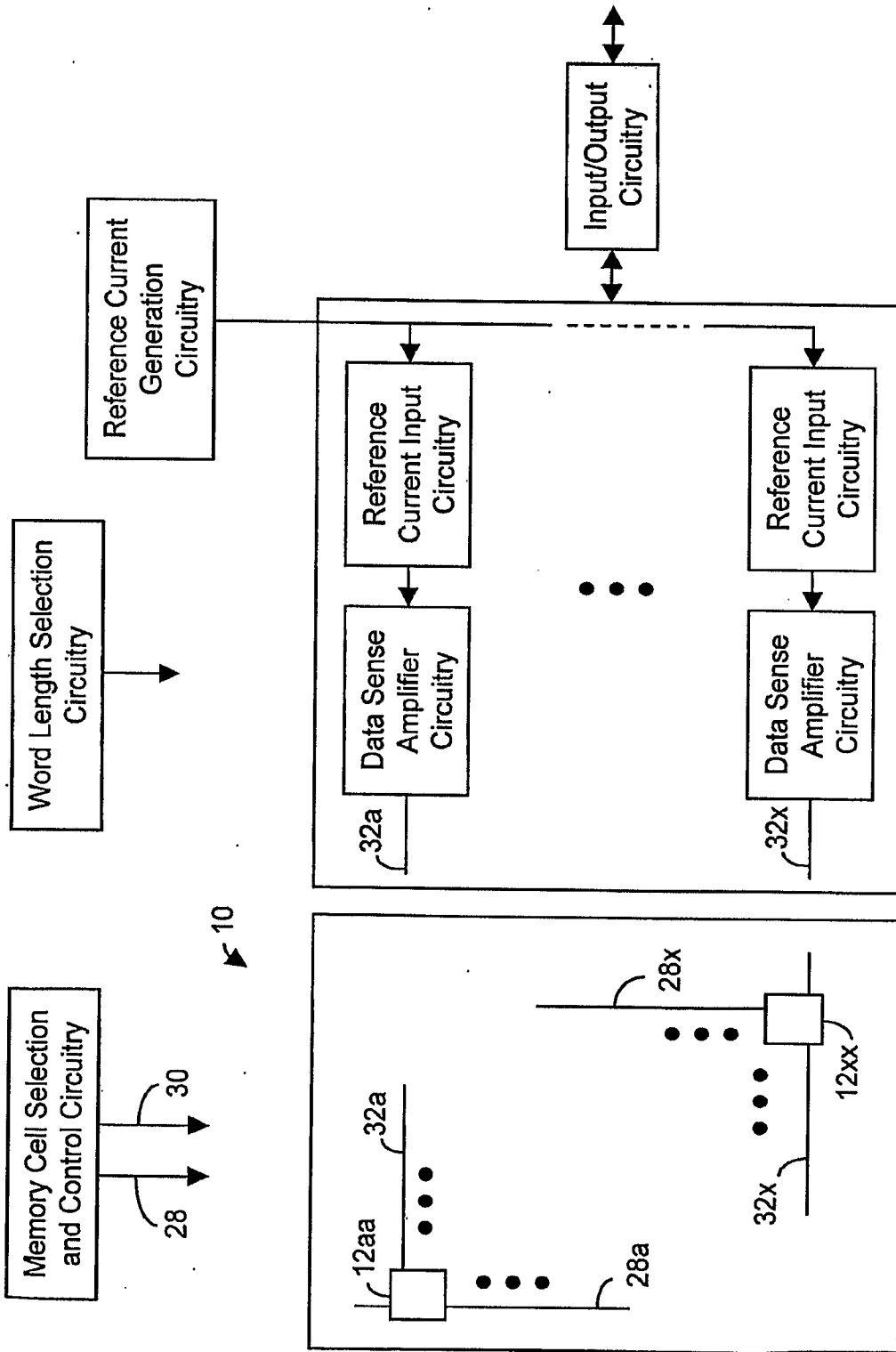

FIGURE 20E

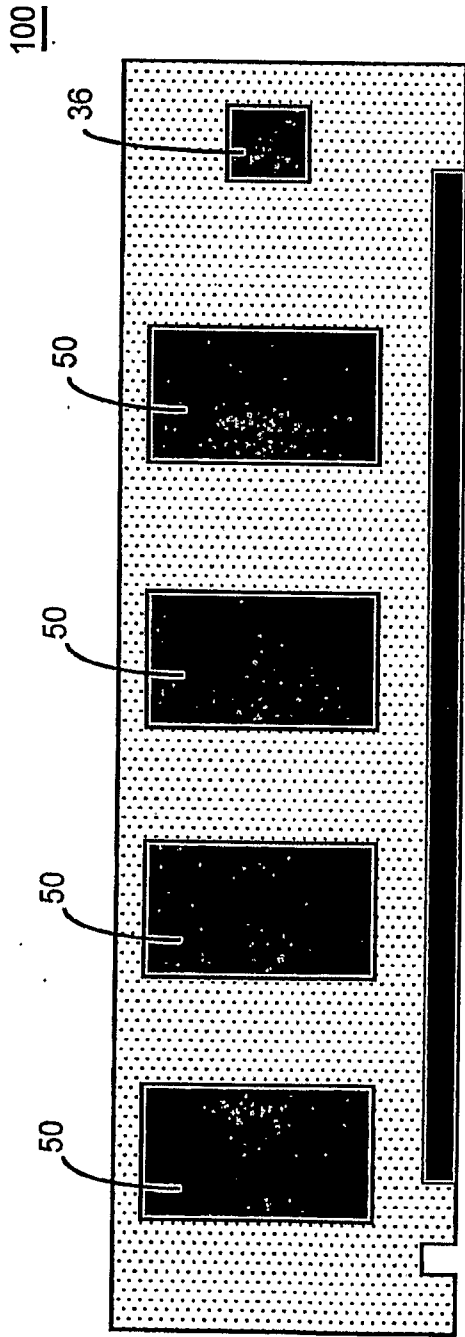

FIGURE 21A

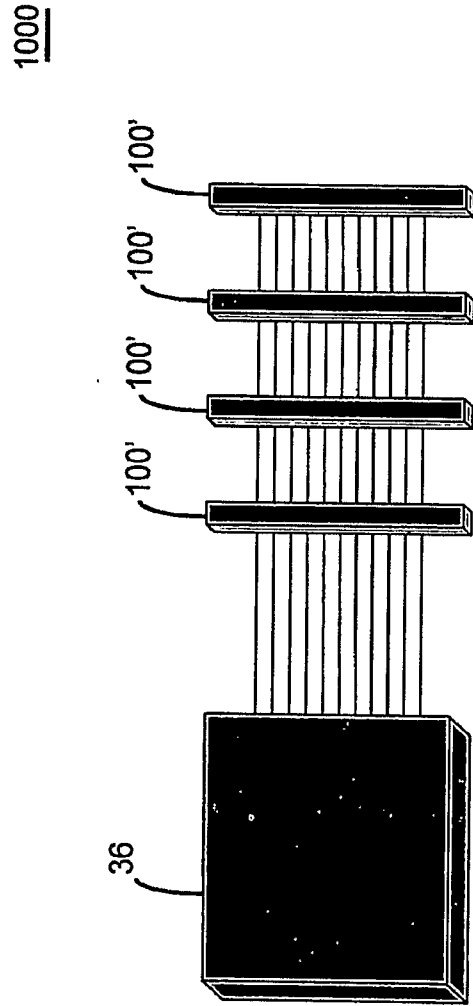

FIGURE 21B

1000

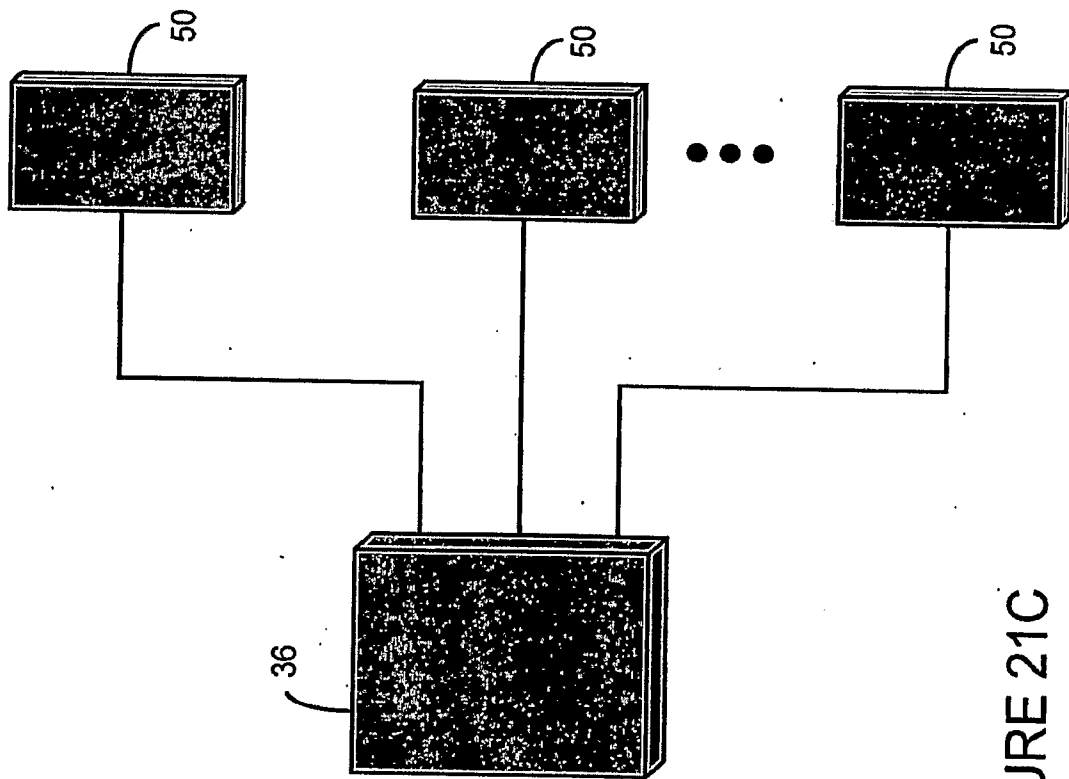

FIGURE 21C