

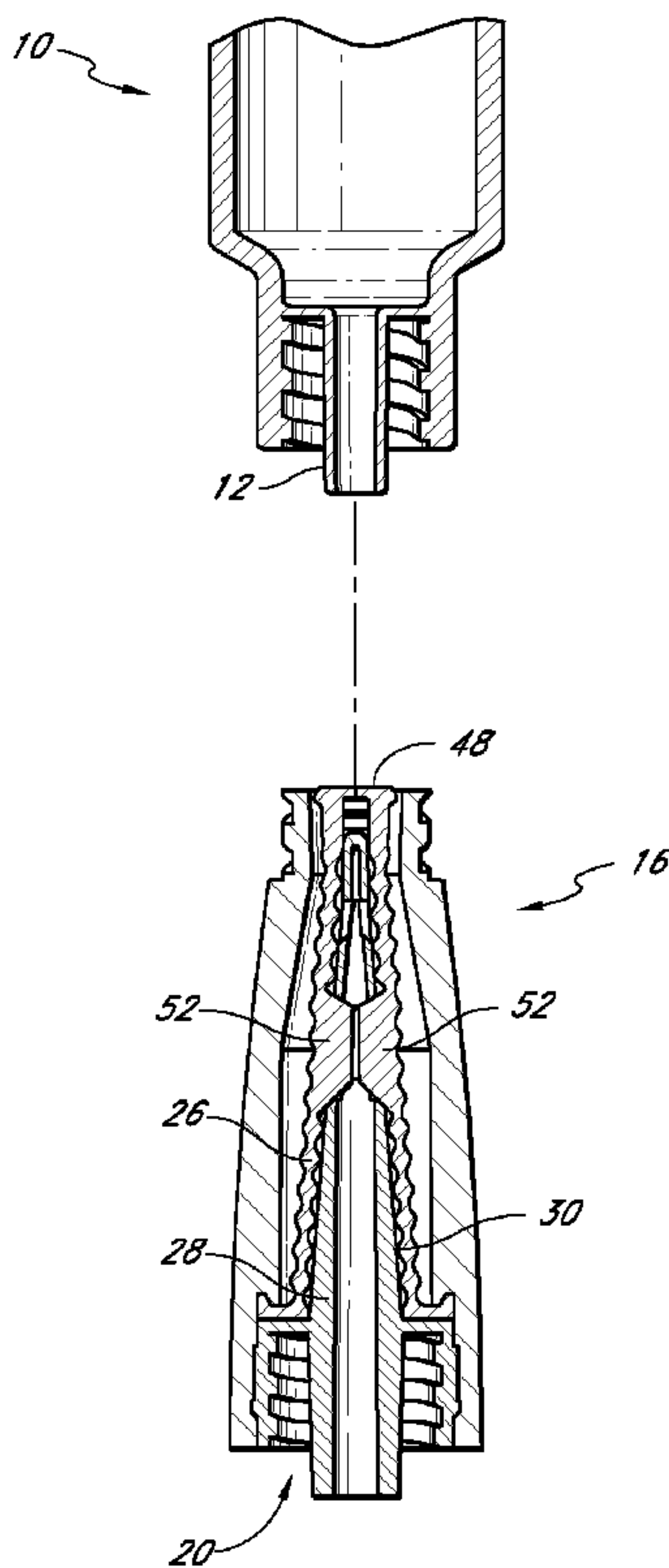

(86) Date de dépôt PCT/PCT Filing Date: 2007/10/25
 (87) Date publication PCT/PCT Publication Date: 2008/05/02
 (45) Date de délivrance/Issue Date: 2015/03/31
 (85) Entrée phase nationale/National Entry: 2009/04/01
 (86) N° demande PCT/PCT Application No.: US 2007/082570
 (87) N° publication PCT/PCT Publication No.: 2008/052140
 (30) Priorité/Priority: 2006/10/25 (US60/854,524)

(51) Cl.Int./Int.Cl. *A61M 39/06* (2006.01),
A61M 39/26 (2006.01)
 (72) Inventeur/Inventor:
FANGROW, THOMAS F., US
 (73) Propriétaire/Owner:
ICU MEDICAL, INC., US
 (74) Agent: SIM & MCBURNEY

(54) Titre : **CONNECTEUR MEDICAL**
 (54) Title: **MEDICAL CONNECTOR**



(57) **Abrégé/Abstract:**

A medical connector for use with one or more medical implements. In some embodiments, the connector minimizes or eliminates the retrograde flow of fluid into the connector from one end or port upon the disconnection of a medical implement from the other end or port. In some embodiments, the connector generates a positive flow of fluid out of the connector from one end or port when a medical implement is disconnected from the other end or port.

(12) INTERNATIONAL APPLICATION PUBLISHED UNDER THE PATENT COOPERATION TREATY (PCT)

(19) World Intellectual Property Organization
International Bureau(43) International Publication Date
2 May 2008 (02.05.2008)

PCT

(10) International Publication Number
WO 2008/052140 A3

(51) International Patent Classification:

A61M 39/06 (2006.01) A61M 39/26 (2006.01)

(21) International Application Number:

PCT/US2007/082570

(22) International Filing Date: 25 October 2007 (25.10.2007)

(25) Filing Language:

English

(26) Publication Language:

English

(30) Priority Data:

60/854,524 25 October 2006 (25.10.2006) US

(71) Applicant (for all designated States except US): ICU
MEDICAL, INC. [US/US]; 951 Calle Amanecer, San
Clemente, CA 92673 (US).

(72) Inventor; and

(75) Inventor/Applicant (for US only): FANGROW,
Thomas, F. [US/US]; 24595 Alcoba Dr., Mission Viejo,
CA 92691 (US).(74) Agent: DELANEY, Karoline, A.; Knobbe Martens Olson
& Bear, LLP, 2040 Main Street, Fourteenth Floor, Irvine,
CA 92614 (US).(81) Designated States (unless otherwise indicated, for every
kind of national protection available): AE, AG, AL, AM,
AT, AU, AZ, BA, BB, BG, BH, BR, BW, BY, BZ, CA, CH,
CN, CO, CR, CU, CZ, DE, DK, DM, DO, DZ, EC, EE, EG,
ES, FI, GB, GD, GE, GH, GM, GT, HN, HR, HU, ID, IL,
IN, IS, JP, KE, KG, KM, KN, KP, KR, KZ, LA, LC, LK,
LR, LS, LT, LU, LY, MA, MD, ME, MG, MK, MN, MW,
MX, MY, MZ, NA, NG, NI, NO, NZ, OM, PG, PH, PL,
PT, RO, RS, RU, SC, SD, SE, SG, SK, SL, SM, SV, SY,
TJ, TM, TN, TR, TT, TZ, UA, UG, US, UZ, VC, VN, ZA,
ZM, ZW.(84) Designated States (unless otherwise indicated, for every
kind of regional protection available): ARIPO (BW, GH,
GM, KE, LS, MW, MZ, NA, SD, SL, SZ, TZ, UG, ZM,
ZW), Eurasian (AM, AZ, BY, KG, KZ, MD, RU, TJ, TM),
European (AT, BE, BG, CH, CY, CZ, DE, DK, EE, ES, FI,
FR, GB, GR, HU, IE, IS, IT, LT, LU, LV, MC, MT, NL, PL,
PT, RO, SE, SI, SK, TR), OAPI (BF, BJ, CF, CG, CI, CM,
GA, GN, GQ, GW, ML, MR, NE, SN, TD, TG).

Declaration under Rule 4.17:

— of inventorship (Rule 4.17(iv))

Published:

— with international search report

(88) Date of publication of the international search report:

19 June 2008

(54) Title: MEDICAL CONNECTOR

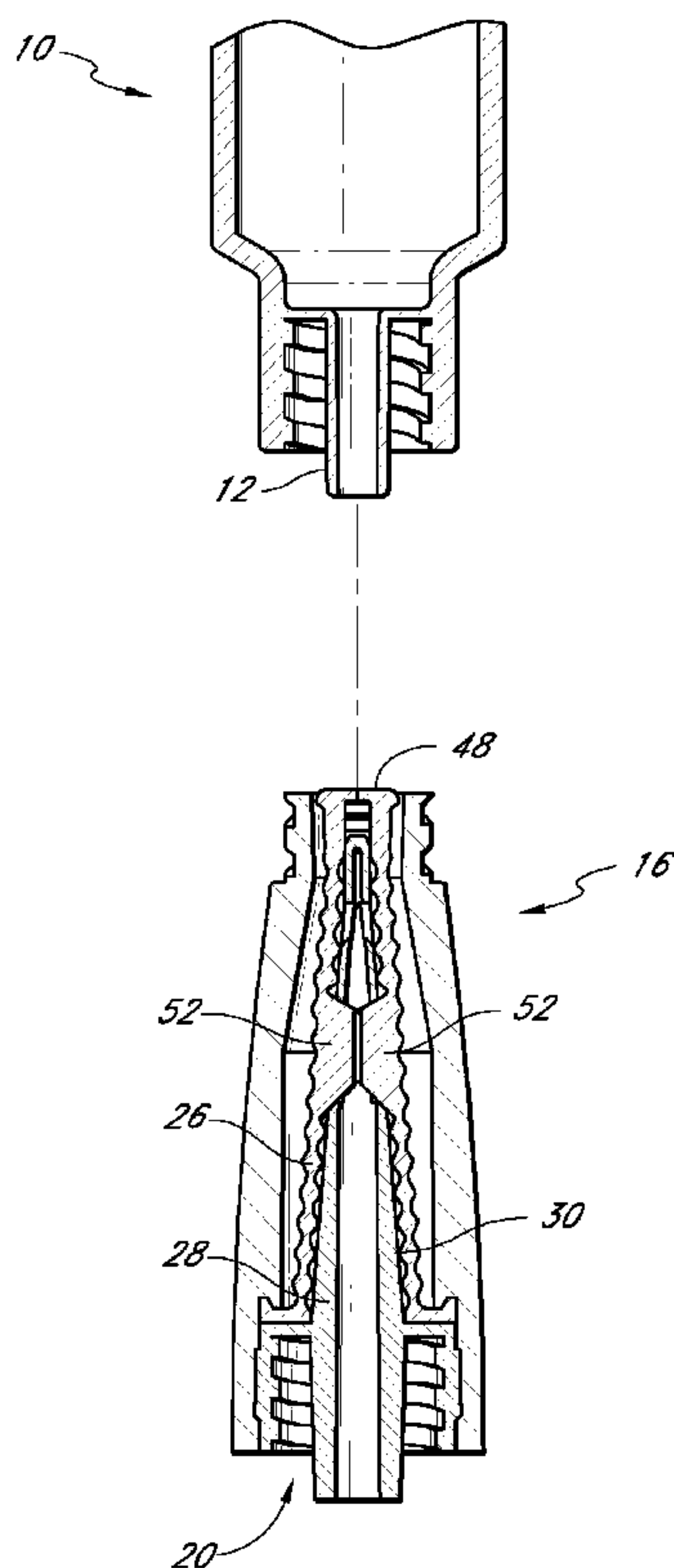

(57) Abstract: A medical connector for use with one or more medical implements. In some embodiments, the connector minimizes or eliminates the retrograde flow of fluid into the connector from one end or port upon the disconnection of a medical implement from the other end or port. In some embodiments, the connector generates a positive flow of fluid out of the connector from one end or port when a medical implement is disconnected from the other end or port.

WO 2008/052140 A3

MEDICAL CONNECTOR

CROSS-REFERENCE TO RELATED APPLICATIONS

[0001] The present application claims the benefit of U.S. Provisional Patent Application No. 60/854,524, filed October 25, 2006 (entitled "MEDICAL CONNECTOR").

BACKGROUND OF THE INVENTION

Field of the Invention

[0002] The inventions relate generally to medical connectors. In particular, certain embodiments of the inventions relate to medical connectors for use with standard luer connectors. In certain embodiments, the medical connectors generate a positive flow of fluid away from a medical implement as the implement is removed from an end or port of the medical connector.

Description of the Related Art

[0003] Medical connectors are often used to selectively open and close fluid pathways for use in treating patients. In some connectors, a small amount of retrograde fluid flow occurs when the connector is closed, drawing fluid away from the patient and toward the connector. This retrograde flow can lead to clotting or obstructions in the fluid line, effectively shortening the time period during which a particular injection point is useable. In many applications, it is advantageous to minimize or eliminate such retrograde flow or to produce a positive flow of fluid toward the patient as the valve closes.

[0004] U.S. Patent No. 6,599,273 includes a general description of some examples of medical connectors in which retrograde fluid flow may occur. U.S. Patent Nos. 6,245,048, 6,428,520, 6,695,817, and U.S. Patent Application Publication No. 2006-0161115A1 include general descriptions of some examples of medical valves in which a positive flow of fluid is produced away from the medical connector and toward the patient as the connector closes. There are many different types of medical connectors, and the foregoing patents are cited merely to illustrate some ways in which fluid can be transferred through connectors. The methods, structures, and principles disclosed herein can be used in or adapted to function

with the connectors (and components thereof) disclosed in the foregoing patents as well as in many different types of medical connectors known or used in this field.

SUMMARY OF THE INVENTION

[0005] In some embodiments, a medical connector for use with a first and second medical implement is described including a housing having a first proximal end and a second distal end, each configured for attachment to standard luer connectors. In some embodiments, the connector further includes an inner rigid element extending within the housing having at least one opening on a side thereof. The inner rigid element may be substantially hollow in its interior with the said opening extending from an outer surface of the inner rigid element to the hollow interior. A substantially hollow flexible element may be positioned within the housing substantially surrounding the inner rigid element. The flexible element may include at least one inward projection on an inner wall thereof, wherein at least a portion of the inward projection may be shaped to cooperate with the opening in the inner rigid element such that when the connector is in a substantially closed position, wherein fluid is not permitted to flow through the connector, the portion of the inward projection is within the opening and when the connector is in a substantially open position, the portion of the inward projection is outside of the opening to permit a reduction in the inner volume of the flexible element and/or the interior of the inner rigid element when the connector is in the substantially closed position.

[0005a] In accordance with an aspect of the present invention there is provided a medical connector for use with a first and second medical implement, the medical connector comprising:

- a housing having a first proximal end and a second distal end;
- an inner rigid element positioned within the housing and including an inner surface defining a substantially hollow interior, a first inner opening on said inner surface, an outer surface, a first outer opening on said outer surface, and a first passage extending between said first inner opening and said first outer opening;
- a substantially hollow flexible element positioned within the housing, said flexible element comprising at least one inward projection on an inner wall thereof, at least a portion of said inward projection projecting through said first outer opening, said first passage, and said first inner opening, thereby occupying at least a portion of the substantially hollow interior of said inner rigid element when said connector is in a substantially closed position, and wherein said portion of said inward projection is positioned outside of said first

outer opening when said connector is in a substantially opened position, the movement of the inward projection out of the first outer opening and back into the first outer opening facilitating a change in an inner fluid volume of the connector when said connector is in said substantially closed position relative to said substantially open position.

[0005b] In accordance with a further aspect of the present invention there is provided a method of transferring fluid from a first medical implement to a second medical implement, the method comprising:

providing a medical connector having a housing with a proximal end and a proximal opening and a distal end and a distal opening, an inner rigid element positioned within said housing and including an inner surface defining a substantially hollow interior, a first inner opening on said inner surface, an outer surface, a first outer opening on said outer surface, a first passage extending between said first inner opening and said first outer opening, and a substantially hollow flexible element positioned within said housing, said flexible element comprising an orifice on a proximal surface, said orifice generally closed with said flexible element in a first position and generally open with said flexible element in a second position, and at least one inward projection on an inner wall thereof, at least a portion of said at least one inward projection projecting through said first outer opening, said first passage, and said first inner opening when said flexible element is in said first position, thereby occupying at least a portion of said substantially hollow interior of said inner rigid element;

coupling said distal end of said housing to a second medical implement;

coupling said proximal end of said housing to a first medical implement wherein a distal end of said first medical implement enters the proximal opening of said housing;

displacing said flexible element by distally delivering said first medical implement within said housing and pushing said flexible element into said second position, wherein said proximal surface of said flexible element is displaced from said proximal opening and said at least one inward projection of said flexible element is displaced from said substantially hollow interior of said inner rigid element; and

establishing fluid communication between said first medical implement and said second medical implement.

[0005c] In accordance with a further aspect of the present invention there is provided a medical connector for use with a first and second medical implement, the medical connector comprising:

a housing having a first proximal end and a second distal end;

an inner rigid element positioned within the housing and including at least one opening on a side thereof and a substantially hollow interior with a fluid flow path, said at least one opening extending from an outer surface of said inner rigid element to said hollow interior of said inner rigid element;

a substantially hollow flexible element positioned within the housing, said flexible element comprising at least one inward projection on an inner wall thereof, at least a portion of said inward projection being shaped to fit within said at least one opening in said inner rigid element when said connector is in a substantially closed position, wherein said portion of said inward projection is positioned within said opening and occupies at least a portion of the fluid flow path of the substantially hollow interior of said inner rigid element in said substantially closed position, and wherein said portion of said inward projection is positioned outside of said opening in a substantially opened position, thereby facilitating a change in an inner fluid volume of said connector when said connector is in said substantially closed position relative to the inner fluid volume of said connector when said connector is in said substantially open position.

[0005d] In accordance with a further aspect of the present invention there is provided a medical connector for use with a first and second medical implement, the medical connector comprising:

a housing having a first proximal end and a second distal end;

an inner rigid element positioned within the housing and including an inner surface, at least one inner opening on said inner surface, an outer surface, at least one outer opening on said outer surface, and a first passage extending between a first inner opening of said at least one inner opening and a first outer opening of said at least one outer opening, wherein the inner rigid element includes a substantially hollow interior defined at least in part by the inner surface and the first passage;

a substantially hollow flexible element positioned within the housing, said flexible element comprising at least one inward projection on an inner wall thereof, at least a portion of a first inward projection of said at least one inward projection projecting through said first outer opening in said inner rigid element and into said first passage when

said connector is in a substantially closed position, and wherein said portion of said first inward projection is positioned outside of said first outer opening and said first passage in a substantially open position, thereby facilitating a change in a volume of the substantially hollow interior of said inner rigid element when said connector is in said substantially closed position relative to the volume of the substantially hollow interior of said inner rigid element when said connector is in said substantially open position.

BRIEF DESCRIPTION OF THE DRAWINGS

[0006] Having thus summarized the general nature of the invention and some of its features and advantages, certain preferred embodiments and modifications thereof will become apparent to those skilled in the art from the detailed description herein having reference to the figures that follow, of which:

[0007] Figure 1 is a side view of a medical connector in a first position and a medical implement according to some embodiments of these inventions.

[0008] Figure 2 is a top perspective view of the medical connector of Figure 1.

[0009] Figure 3 is a bottom perspective view of the medical connector of Figure 1.

[0010] Figure 4 is an exploded perspective view of the medical connector of Figure

[0011] Figure 5 is a bottom perspective view of a component of a medical connector according to some embodiments of these inventions.

[0012] Figure 6A is a cross-sectional view of the medical connector component of Figure 5.

[0013] Figure 6B is a cross-sectional view of the medical connector component of Figure 6A rotated 90 degrees.

[0014] Figure 7A is a cross-sectional view of a component for a medical connector according to some embodiments of these inventions.

[0015] Figure 7B is a cross-sectional view of the medical connector component of Figure 7A rotated 90 degrees.

[0016] Figure 8A is a cross-sectional view of a medical connector in a first position and a medical implement according to some embodiments of these inventions.

[0017] Figure 8B is a cross-sectional view of the medical connector and medical implement of Figure 8A rotated 90 degrees.

[0018] Figure 9A is a cross-sectional view of a medical connector engaged with a medical implement according to some embodiments of these inventions.

[0019] Figure 9B is a cross-sectional view of the medical connector and medical implement of Figure 9A rotated 90 degrees.

DETAILED DESCRIPTION OF THE PREFERRED EMBODIMENT

[0020] While the description sets forth various embodiment specific details, it will be appreciated that the description is illustrative only and should not be construed in any way as limiting the invention. Furthermore, various applications of the invention, and modifications thereto, which may be apparent to those who are skilled in the art, are also encompassed by the general concepts described herein.

[0021] Figure 1 illustrates a male luer connector 10 with a luer end 12 and a luer lock 14 approaching a female connector 16. The female connector 16 has a proximal end 18,

a distal end 20, with a male luer 22 on its distal end. The distal end 20 may further include a luer lock. The female connector 16 includes a housing 24. Figure 2 illustrates a perspective view of the female connector 16. The proximal end 48 of a flexible element 26 is illustrated. The flexible element 26 may include an orifice 27 that is normally closed until a distally directed force is applied to flexible element 26. Figure 3 illustrates a perspective view of the connector 16 in which the male luer 22 on the distal end 20 of the connector is visible.

[0022] Figure 4 is an exploded perspective view of the connector 16 of Figure 2. Some of the internal components of connector 16 are illustrated, such as flexible element 26 and rigid element 28. In some embodiments of the assembled configuration, an inner rigid element 30 is provided and can fit within a cavity 32 inside of flexible element 26. Orifice 27 is shown closed in this exploded perspective view. In some embodiments, orifice 27 is open when flexible element 26 is separate from housing 24. In some embodiments, contact between the inner cavity of the housing 24 and portions of the proximal end 48 of flexible element 26 upon insertion of flexible element 26 into housing 24 may cooperate to substantially close orifice 27 such that the fluid flow path through connector 16 is impeded.

[0023] Figure 5 illustrates a perspective view of rigid element 28 having a proximal end 31 and a distal end 33. Distal end 33 may include radially projecting elements 35. Radial elements 35 interact with corresponding features in the internal wall of housing 24 to secure rigid element 28 within housing 24 upon assembly of the connector 16. Radial elements 35 extending along the longitudinal axis of connector 16 may interact with housing 24 to inhibit rotation of rigid element 28 inside of housing 24 when connector 16 is manipulated, for example when a female connector is attached to the distal end 20 of connector 16.

[0024] In some embodiments, inner rigid element 30 has multiple openings. For example, openings 34 can be used to permit fluid to flow into an internal passage or fluid-flow path 36 inside of inner rigid element 30. In some embodiments, two openings 34 are disposed on opposite sides of inner rigid element 30. Additional openings similar to opening 34 can also be provided. In some embodiments, an opening can be provided at the proximal end 31 of inner rigid element 30. In some embodiments, one or more of openings 34 and 38 are combined (*i.e.*, the same openings(s) are configured to receive fluid and to receive one or

more protrusions 52 (*see* Figure 7A). Inner rigid element 30 may be blunt, pointed, opened-ended, closed-ended, or shorter or longer, or wider or narrower than shown here. Inner rigid element 30 may have many different shapes. For example, it may be configured as a tube-like structure as shown, configured as a sleeve with one or more longitudinal openings or slits extending partially along the length of the sleeve or along the entire length of the sleeve, or the inner rigid element 30 may be eliminated entirely. Inner rigid element 30 may be in a fixed position inside of the housing 24 or it may be moveable or floating inside of the housing 24. In the absence of inner rigid element 30, one or more fluid openings may be provided at or near a distal region of the cavity inside the housing to convey fluid within the housing cavity to the male end of the connector.

[0025] In some embodiments, one or more openings 38 are provided in inner rigid element 30, and may be located in a direction distal from opening 34. As will be described below, in some embodiments, opening 38 is intended to receive a protrusion on an internal surface of flexible element 26 when the connector 16 is in the closed configuration (*see* Figure 8A). In some embodiments, opening 38 is adapted to receive fluid flow. Where opening 38 is used to facilitate fluid flow through inner rigid element 30, opening 34 may or may not be included.

[0026] Figures 6A and 6B illustrate orthogonal cross-sections of rigid element 28 taken in a vertical plane. In some embodiments, as illustrated, the proximal edges 40, 42 of openings 34, 38 can be flat and substantially horizontal, and the distal edges 44, 46 of openings 34, 38 can be slanted or beveled.

[0027] As illustrated, the fluid-flow path 36 may extend from the proximal end of the inner rigid element 30 along a generally axially-oriented linear path to the male end 22. In some embodiments, as illustrated, the fluid-flow path 36 in the distal region of the inner rigid element 30 is generally non-tortuous; for example, the fluid-flow path 36 may not turn in a direction that is perpendicular to or substantially non-parallel with the axis of the inner rigid element 30, and/or it may not include fluid-exiting side openings in the distal region of the inner rigid element 30. Such a fluid-flow path may provide a higher fluid flow rate and create less turbulence in the fluid flow (which can be especially advantageous when the fluid includes blood cells).

[0028] Figures 7A and 7B illustrate orthogonal cross-sections of flexible element 26 taken in a vertical plane. Flexible element 26 can be longitudinally compressed and/or moved by a force applied to the proximal end 48 toward the distal end 50. A plurality of inwardly projecting elements 52 are provided in an internal cavity 32 of flexible element 26. In some embodiments, there is one such protrusion 52. In the illustrated embodiment, there are two protrusions 52. In some embodiments, there can be multiple openings 38, some of which can be positioned along different regions of inner rigid element 30, and there can be additional corresponding protrusions 52 that can be designed to selectively fit within or be withdrawn from one or more openings 38. In some embodiments, as shown, the internal edges or faces 53 of the opposing protrusions 52 can be positioned and oriented to contact each other and/or be close to each other when the connector 16 is in a substantially closed position. The protrusions 52 can extend into the inner rigid element 30 at an intermediate position within the fluid-flow path 36 of the inner rigid element 30. In some embodiments, the wall of the inner rigid element 30 is not positioned between the opposing edges or faces 53 of the protrusions 52 in the substantially opened position. Openings 38 can have a variety of different shapes and sizes. For example, one or more of openings 38 can be round, square, rectangular, trapezoidal, elliptical, etc. Opening 38 can be larger than opening 34. In some embodiments, opening 38 can be approximately at least one-fifth, one-quarter, one-third, one-half, or more of the length of inner rigid element 30. Protrusions 52 can also have a variety of different shapes and sizes, which may correspond to or be different from the shapes and/or sizes of openings 38. As shown, the protrusions 52 can be substantially planar. In some embodiments, the volume of the one or more protrusions 52 can be approximately equivalent to or greater than the volume in the proximal region of the connector adapted to receive the luer 12.

[0029] In some embodiments, upper or proximal edges 54 of protrusions 52 can be slanted and/or beveled. Similarly, lower or distal edges 56 of protrusions 52 can be also slanted and/or beveled. Slanting or beveling these surfaces may facilitate fluid flow through the connector 16 and may minimize turbulence in the fluid flow. In general, the shape, materials, and structure of rigid element 28 and flexible element 26 can be selected to allow protrusions 52 to be positioned within openings 38 when the connector is closed, and

protrusions 52 can be completely or partially withdrawn from openings 38 when the connector is opened. When the connector 16 is in the substantially closed position, the inward protrusions 52 function so as to reduce the fluid space within the connector 16 and the fluid flow path as compared to when the connector 16 is in the substantially open position.

[0030] In some embodiments, flexible element 26 can be made of silicon, and the remaining components of connector 16 can be made of a polymer material such as polycarbonate. A proximal region 58 of flexible element 26 can include a portion with an increased wall thickness or a structure (or materials of composition) that contribute to the proximal region 58 being stiffer or harder than the portion of the flexible element 26 that flexes during compression. By providing increased stiffness or hardness for the proximal region 58, there is a lower likelihood that fluid within the valve will be forced back into the fluid path 32 inside of flexible element 26 as flexible element 26 expands to its original height when the valve is closed. Moreover, in some embodiments, a proximal portion 60 of fluid pathway 32 inside the flexible element 26 has a horizontal cross-sectional area that is substantially less than the horizontal cross-sectional area of a region in the fluid path 36 of element 28, so that fluid flow out of the distal end of the connector is encouraged and retrograde fluid flow toward the proximal end of the connector is discouraged.

[0031] In some embodiments, orifice 27 extends along an axis substantially perpendicular to inward projections 52, as shown in Figure 7A. In other embodiments, orifice 27 extends along substantially the same plane as projections 52.

[0032] As shown in Figures 7A and B, proximal portion 60 may include a non-rotationally symmetrical cross-sectional diameter. In some embodiments, the proximal portion 60 has smaller cross-sectional diameter in the plane perpendicular to orifice 27 and a larger cross-sectional diameter in the plane of orifice 27. In some embodiments, portions of proximal portion 60 have a substantially rectangular cross-sectional area.

[0033] Figure 8A illustrates a vertical cross-section of the male luer 10 and female connector 16 illustrated in Figure 1. In Figures 8A and 8B, a portion of rigid element 28 is positioned within the internal cavity 32 of flexible element 26. Inward protrusions 52 are positioned within openings 38, and more particularly, in the fluid flow path through connector 16. Fluid flow within connector 16 is substantially occluded. The

proximal end 48 of flexible element 26 may be swabbable with antiseptic in a sweeping motion across the proximal end 18 of the connector 16, and the proximal end 48 may extend above the housing, may be substantially flush with the housing, or may be recessed within the housing.

[0034] Figures 9A and 9B illustrate an embodiment of the female connector 16 after it is connected to the male luer connector 10 in orthogonal vertical cross-sections. In some embodiments, flexible element 26 can be compressed and/or moved by a distally directed force applied by the male luer 12. As shown, a portion of inner rigid element 30 can extend in a proximal direction beyond orifice 27 during compression. In some embodiments, inner rigid element 30 does not extend further in a proximal direction than the proximal end 48 of the flexible element 26 when compressed. In some embodiments, orifice 27 may automatically open to allow fluid flow through the connector 16 upon insertion of the male luer connector 10 into connector 16.

[0035] In Figures 9A and 9B, the medical connector 16 is substantially open to fluid flow between the male luer 10 and the distal end 20 of the female connector 16. As shown in Figure 9A, the protrusions 52 can be partially or completely withdrawn from the openings 38 so that the volume inside of the fluid path 36 during the open stage of the connector 16 is substantially larger than the fluid volume inside of the fluid path 36 when the connector 16 is closed (*see, e.g.*, Figure 8A). This can diminish, or eliminate, retrograde fluid flow from the patient toward the proximal end 18 of the connector 16, or even produce a positive flow of fluid upon closure in the direction of the distal end 20 of the connector 16 and toward the patient. In some embodiments, proximal region 58 resists compression to a greater extent than a region on flexible element 26 positioned distal from the region 58 during the insertion of the male luer connector 10 into the female connector 16. Proximal region 58 can substantially maintain its height, before and after compression and/or movement, as fluid flow is enabled through the connector 16, which may reduce any vacuum effect in this portion of flexible element 26.

[0036] The foregoing description is provided to illustrate certain examples. The inventive concepts, principles, structures, steps, and methods disclosed herein can be

applied to the devices and methods disclosed in the attached patents and in many other types of medical connectors.

THE CLAIMS ARE:

1. A medical connector for use with a first and second medical implement, the medical connector comprising:

a housing having a first proximal end and a second distal end;

an inner rigid element positioned within the housing and including an inner surface defining a substantially hollow interior, a first inner opening on said inner surface, an outer surface, a first outer opening on said outer surface, and a first passage extending between said first inner opening and said first outer opening;

a substantially hollow flexible element positioned within the housing, said flexible element comprising at least one inward projection on an inner wall thereof, at least a portion of said inward projection projecting through said first outer opening, said first passage, and said first inner opening, thereby occupying at least a portion of the substantially hollow interior of said inner rigid element when said connector is in a substantially closed position, and wherein said portion of said inward projection is positioned outside of said first outer opening when said connector is in a substantially opened position, the movement of the inward projection out of the first outer opening and back into the first outer opening facilitating a change in an inner fluid volume of the connector when said connector is in said substantially closed position relative to said substantially open position.

2. The connector of Claim 1, wherein said flexible element further comprises an orifice on a proximal end thereof.

3. The connector of Claim 2, wherein said orifice is naturally biased to an open position when said connector is in said substantially open position.

4. The connector of Claim 2, wherein said inner rigid element penetrates said orifice when said connector is in said substantially open position.

5. The connector of Claim 2, wherein said change of said inner fluid volume of said connector establishes a flow of fluid out of the distal end of said housing as said connector transitions from said substantially open position to said substantially closed position.

6. The connector of Claim 2, wherein said portion of said inward projection includes a slanted surface on a distal side thereof to facilitate the movement of said portion into and out of said first outer opening in said inner rigid element.

7. The connector of Claim 6, wherein a distal side of said first passage in said inner rigid element comprises a slanted portion cooperating with said distal side of said inward projection to further facilitate the movement of said portion into and out of said first outer opening in said inner rigid element.

8. The connector of Claim 1, wherein said inner rigid element includes a proximal end and a distal end, said proximal end being closer to said proximal end of said housing, said rigid element further comprising a second flow opening positioned between said first outer opening and said proximal end of said inner rigid element.

9. The connector of Claim 1, wherein said change of said inner fluid volume of said connector eliminates a flow of fluid into the distal end of said housing as said connector transitions from said substantially open position to said substantially closed position.

10. A method of transferring fluid from a first medical implement to a second medical implement, the method comprising:

providing a medical connector having a housing with a proximal end and a proximal opening and a distal end and a distal opening, an inner rigid element positioned within said housing and including an inner surface defining a substantially hollow interior, a first inner opening on said inner surface, an outer surface, a first outer opening on said outer surface, a first passage extending between said first inner opening and said first outer opening, and a substantially hollow flexible element positioned within said housing, said flexible element comprising an orifice on a proximal surface, said orifice generally closed with said flexible element in a first position and generally open with said flexible element in a second position, and at least one inward projection on an inner wall thereof, at least a portion of said at least one inward projection projecting through said first outer opening, said first passage, and said first inner opening when said flexible element is in said first position, thereby occupying at least a portion of said substantially hollow interior of said inner rigid element;

coupling said distal end of said housing to a second medical implement;

coupling said proximal end of said housing to a first medical implement wherein a distal end of said first medical implement enters the proximal opening of said housing;

displacing said flexible element by distally delivering said first medical implement within said housing and pushing said flexible element into said second position, wherein said proximal surface of said flexible element is displaced from said

proximal opening and said at least one inward projection of said flexible element is displaced from said substantially hollow interior of said inner rigid element; and

establishing fluid communication between said first medical implement and said second medical implement.

11. The method of transferring fluid of Claim 10, wherein said at least one inward projection is external to said inner rigid element when the flexible element is in said second position.

12. The method of transferring fluid of Claim 10, wherein a proximal end of said inner rigid element extends through said orifice of said flexible element in said second position.

13. The method of transferring fluid of Claim 10, further comprising said step of decoupling said housing and said second medical implement, whereby said flexible element returns to said first position and said at least one inward projection extends through said first outer opening, said first passage, and said first inner opening, thereby occupying said portion of said substantially hollow interior of said inner rigid element.

14. The method of transferring fluid of Claim 13, wherein a volume of said at least one inward projection projecting through said first outer opening, said first passage, and said first inner opening substantially eliminates a flow of fluid into said distal end of said housing as said flexible element transitions from said second position to said first position.

15. The method of transferring fluid of Claim 10, wherein said at least one inward projection comprises a slanted surface on a distal side thereof to facilitate said movement of said portion of said at least one inward projection into and out of said first outer opening in said inner rigid element.

16. The method of transferring fluid of Claim 15, wherein a distal side of said first passage in said inner rigid element comprises a slanted portion cooperating with said distal side of said at least one inward projection to further facilitate said movement of said portion of said at least one inward projection into and out of said first outer opening in said inner rigid element.

17. A medical connector for use with a first and second medical implement, the medical connector comprising:

a housing having a first proximal end and a second distal end;

an inner rigid element positioned within the housing and including at least one opening on a side thereof and a substantially hollow interior with a fluid flow path,

said at least one opening extending from an outer surface of said inner rigid element to said hollow interior of said inner rigid element;

a substantially hollow flexible element positioned within the housing, said flexible element comprising at least one inward projection on an inner wall thereof, at least a portion of said inward projection being shaped to fit within said at least one opening in said inner rigid element when said connector is in a substantially closed position, wherein said portion of said inward projection is positioned within said opening and occupies at least a portion of the fluid flow path of the substantially hollow interior of said inner rigid element in said substantially closed position, and wherein said portion of said inward projection is positioned outside of said opening in a substantially opened position, thereby facilitating a change in an inner fluid volume of said connector when said connector is in said substantially closed position relative to the inner fluid volume of said connector when said connector is in said substantially open position.

18. The connector of Claim 17, wherein said flexible element further comprises an orifice on a proximal end thereof.

19. The connector of Claim 18, wherein said orifice is naturally biased to an open position when said connector is in said substantially open position.

20. The connector of Claim 18, wherein said inner rigid element penetrates said orifice when said connector is in said substantially open position.

21. The connector of Claim 18, wherein said change in said inner fluid volume of said connector establishes a flow of fluid out of the distal end of said housing upon the removal of a medical implement from said connector.

22. The connector of Claim 18, wherein said portion of said inward projection includes a slanted surface on a distal side thereof to facilitate the movement of said portion of said inward projection into and out of said opening in said inner rigid element.

23. The connector of Claim 22, wherein a proximal side of said opening in said inner rigid element comprises a slanted portion cooperating with said distal side of said inward projection to further facilitate the movement of said portion of said inward projection into and out of said opening in said inner rigid element.

24. A medical connector for use with a first and second medical implement, the medical connector comprising:

a housing having a first proximal end and a second distal end;

an inner rigid element positioned within the housing and including an inner surface, at least one inner opening on said inner surface, an outer surface, at least one outer opening on said outer surface, and a first passage extending between a first inner opening of said at least one inner opening and a first outer opening of said at least one outer opening, wherein the inner rigid element includes a substantially hollow interior defined at least in part by the inner surface and the first passage;

a substantially hollow flexible element positioned within the housing, said flexible element comprising at least one inward projection on an inner wall thereof, at least a portion of a first inward projection of said at least one inward projection projecting through said first outer opening in said inner rigid element and into said first passage when said connector is in a substantially closed position, and wherein said portion of said first inward projection is positioned outside of said first outer opening and said first passage in a substantially open position, thereby facilitating a change in a volume of the substantially hollow interior of said inner rigid element when said connector is in said substantially closed position relative to the volume of the substantially hollow interior of said inner rigid element when said connector is in said substantially open position.

25. The connector of Claim 24, wherein said flexible element further comprises an orifice on a proximal end thereof.

26. The connector of Claim 25, wherein said orifice is naturally biased to an open position when said connector is in said substantially open position.

27. The connector of Claim 25, wherein said inner rigid element penetrates said orifice when said connector is in said substantially open position.

28. The connector of Claim 25, wherein said change in said volume of the substantially hollow interior of said inner rigid element establishes a flow of fluid out of the distal end of said housing upon the removal of a medical implement from said connector.

29. The connector of Claim 25, wherein said portion of said first inward projection includes a slanted surface on a distal side thereof to facilitate the movement of said portion of said first inward projection into and out of said first outer opening in said inner rigid element.

30. The connector of Claim 29, wherein a distal side of said first passage in said inner rigid element comprises a slanted portion cooperating with said distal side of said first inward projection to further facilitate the movement of said portion of said first inward projection into and out of said first outer opening in said inner rigid element.

1/10

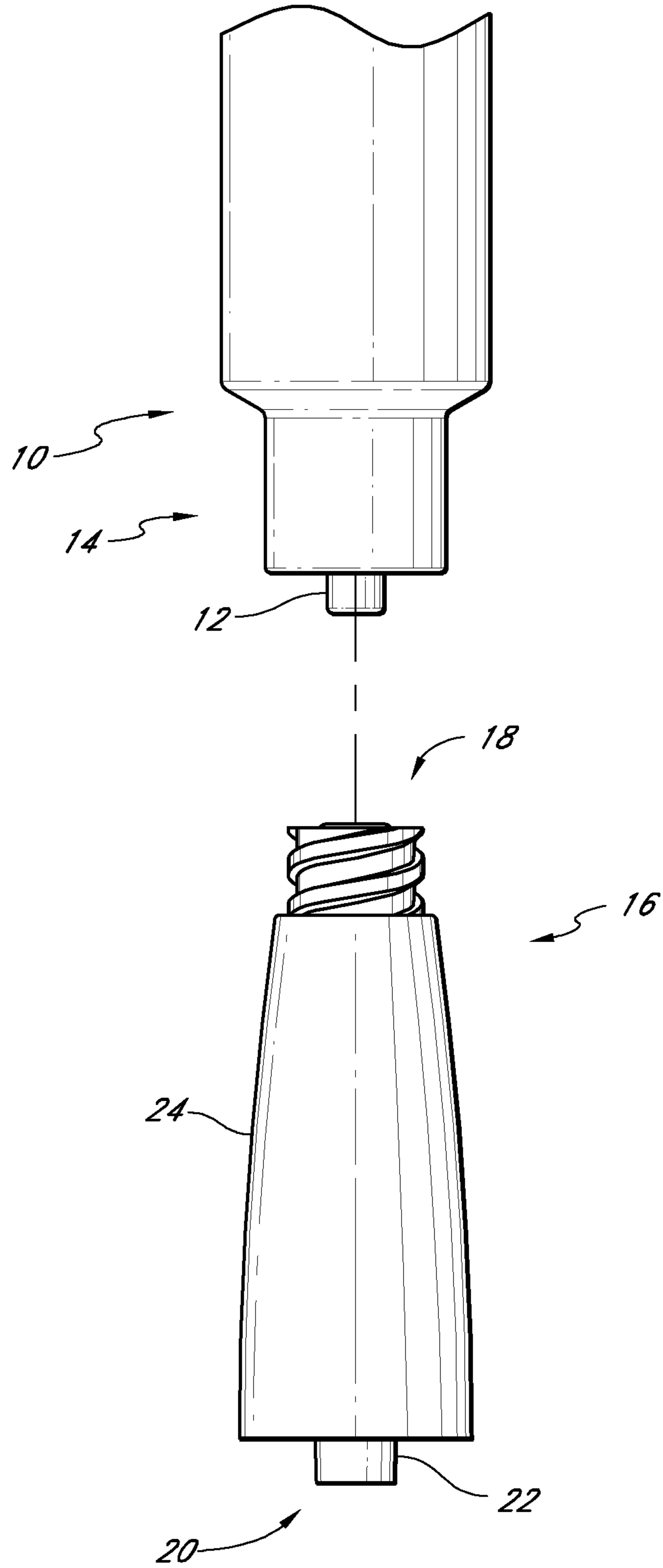

FIG. 1

2/10

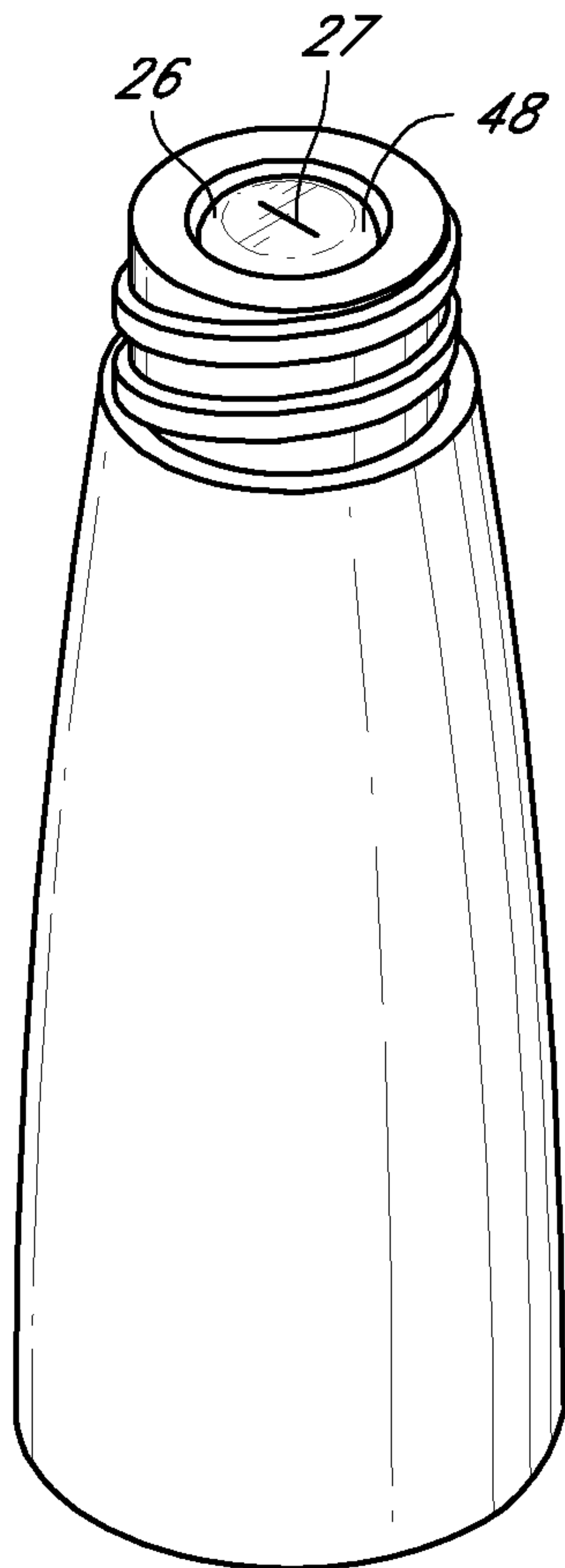

FIG. 2

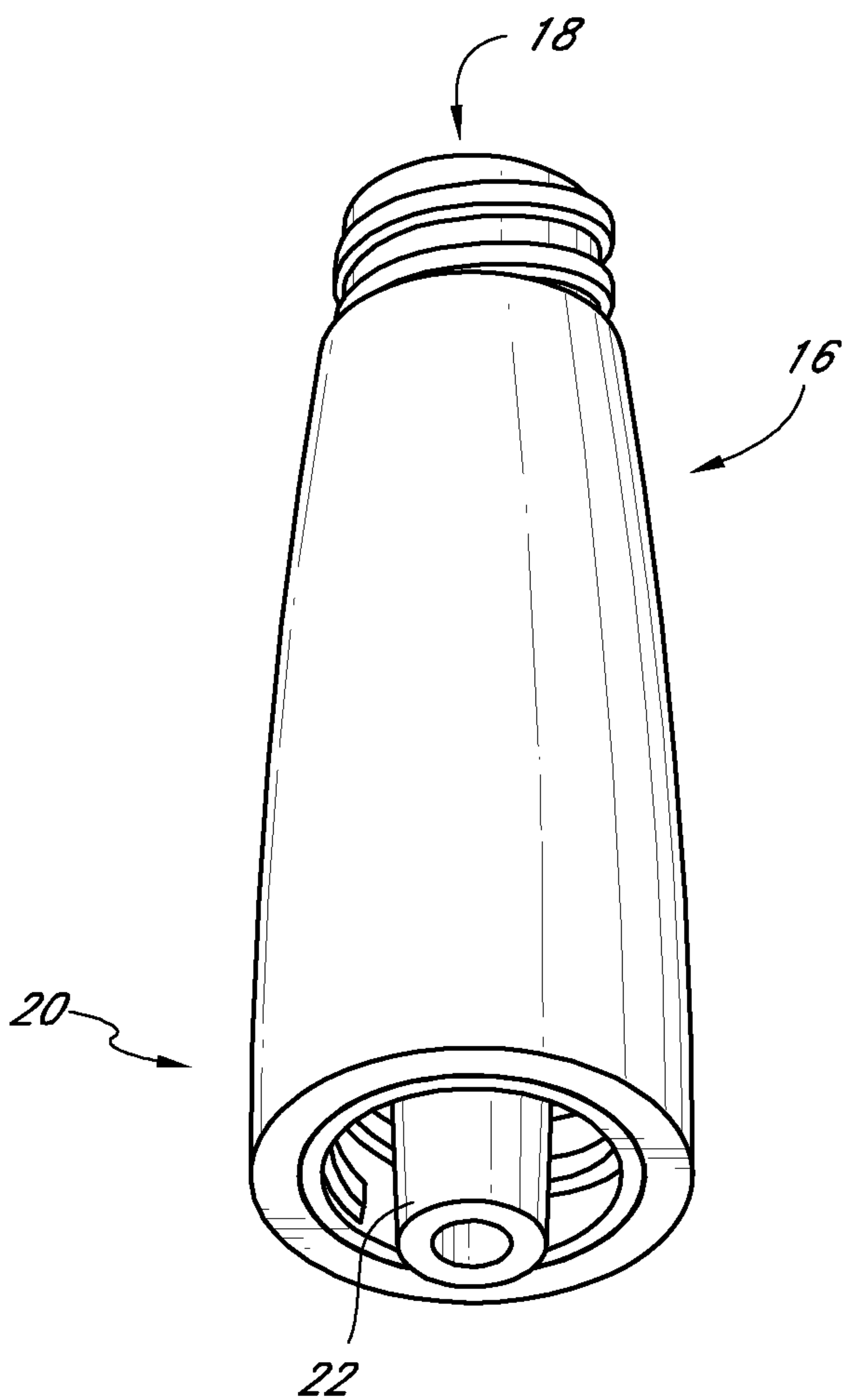

FIG. 3

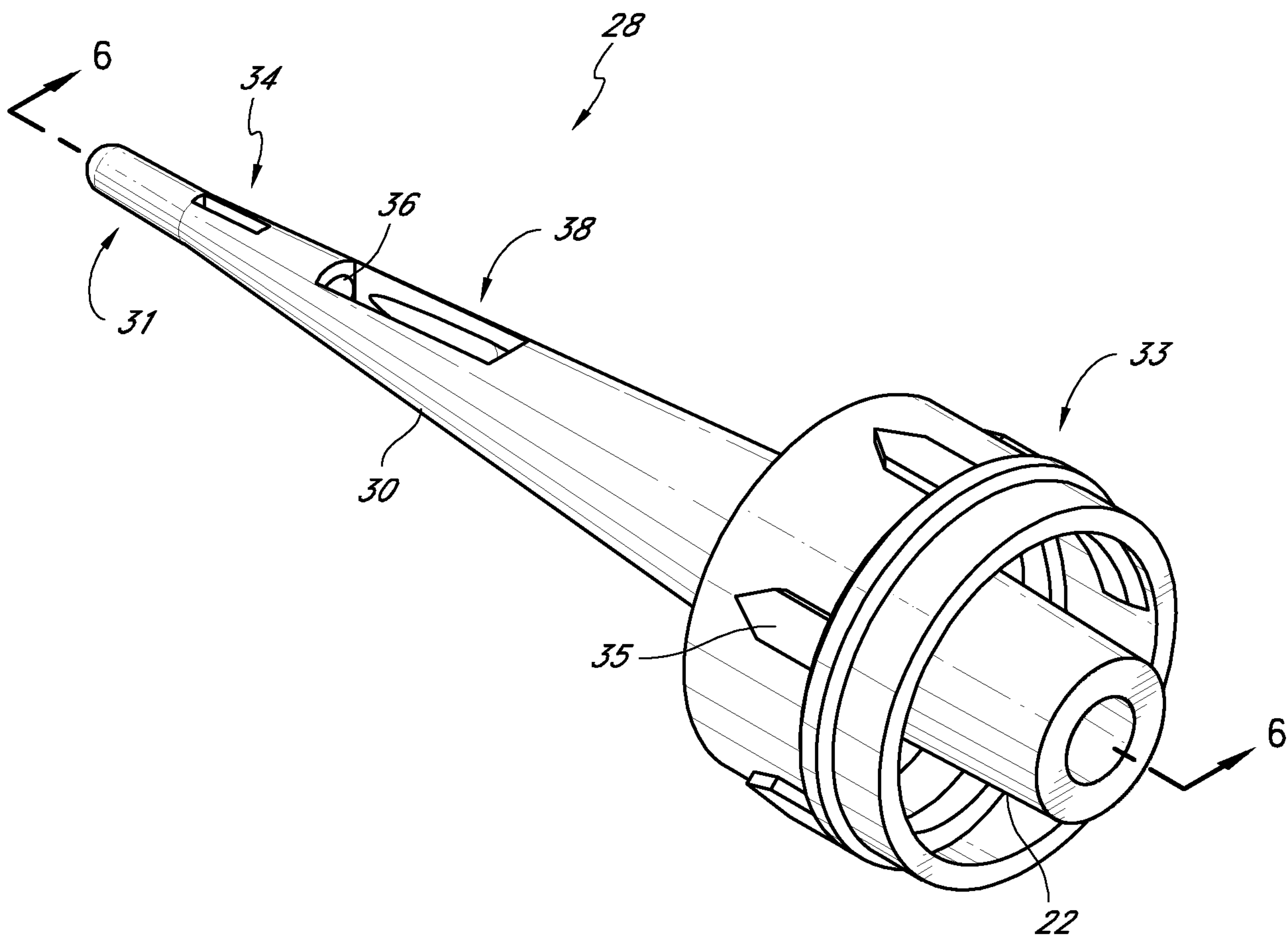

FIG. 5

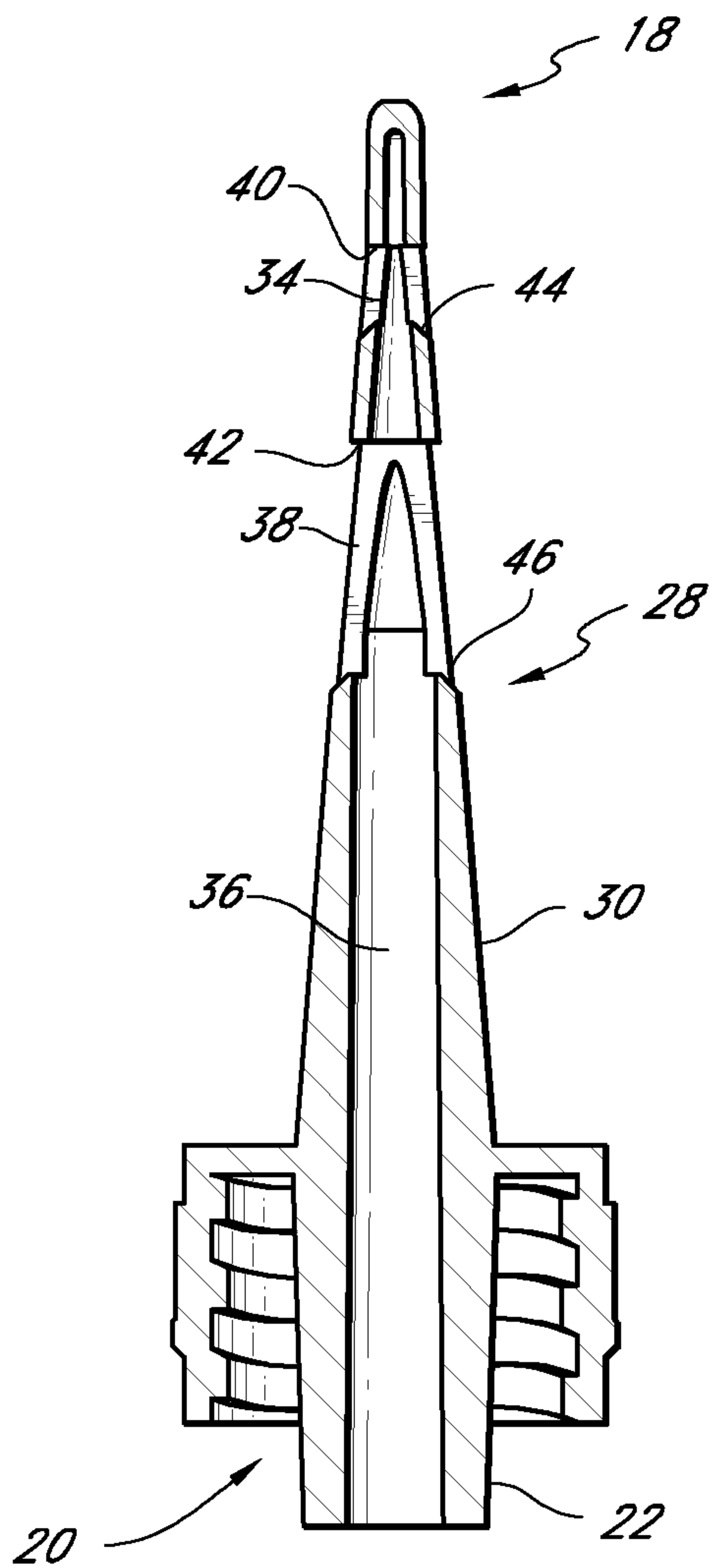

FIG. 6A

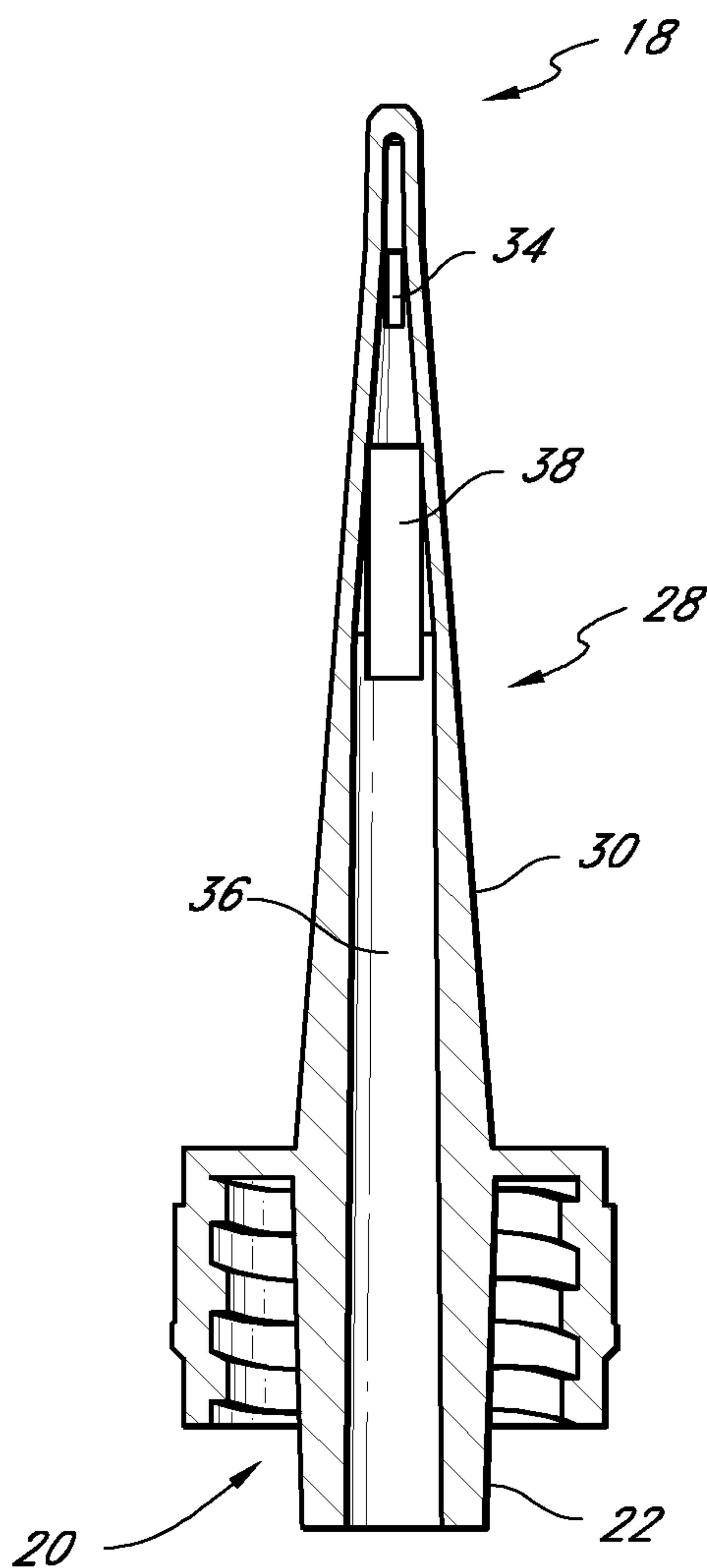

FIG. 6B

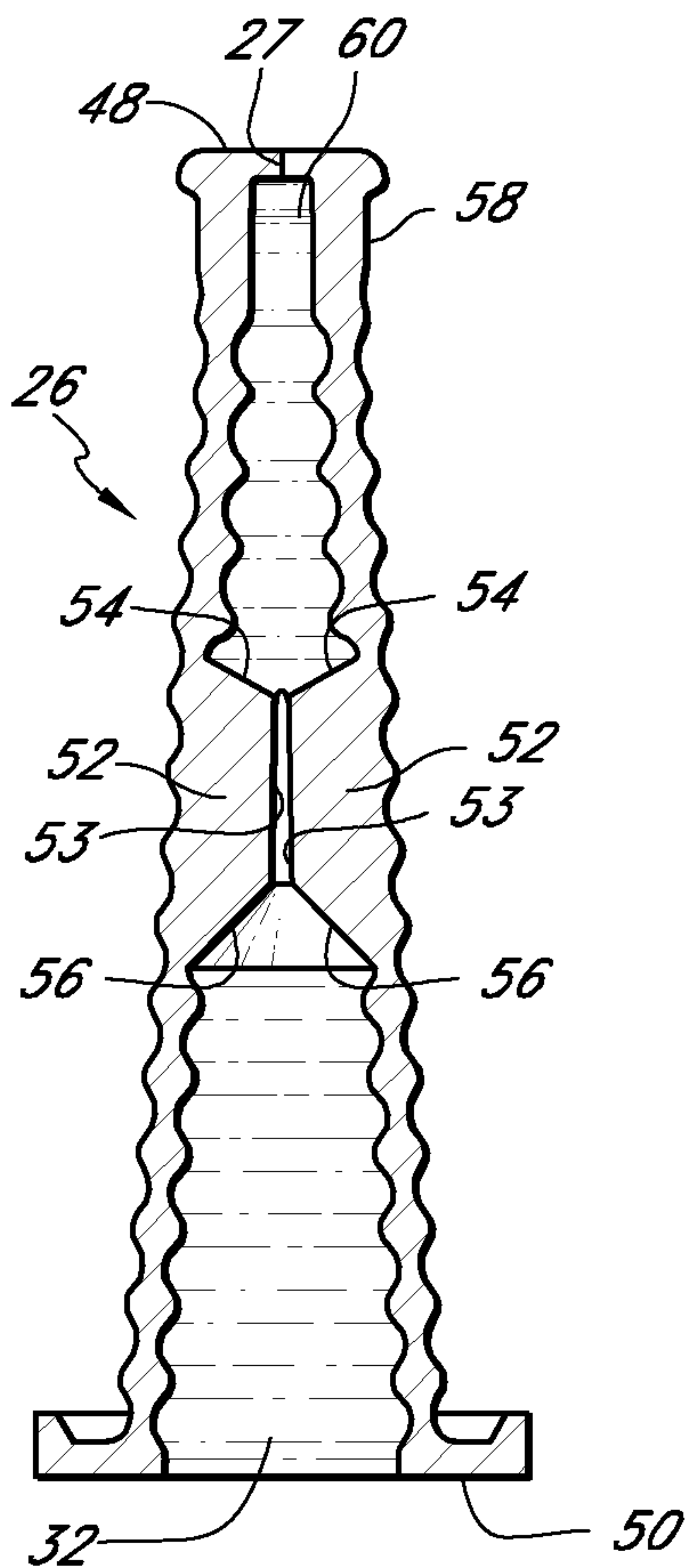

FIG. 7A

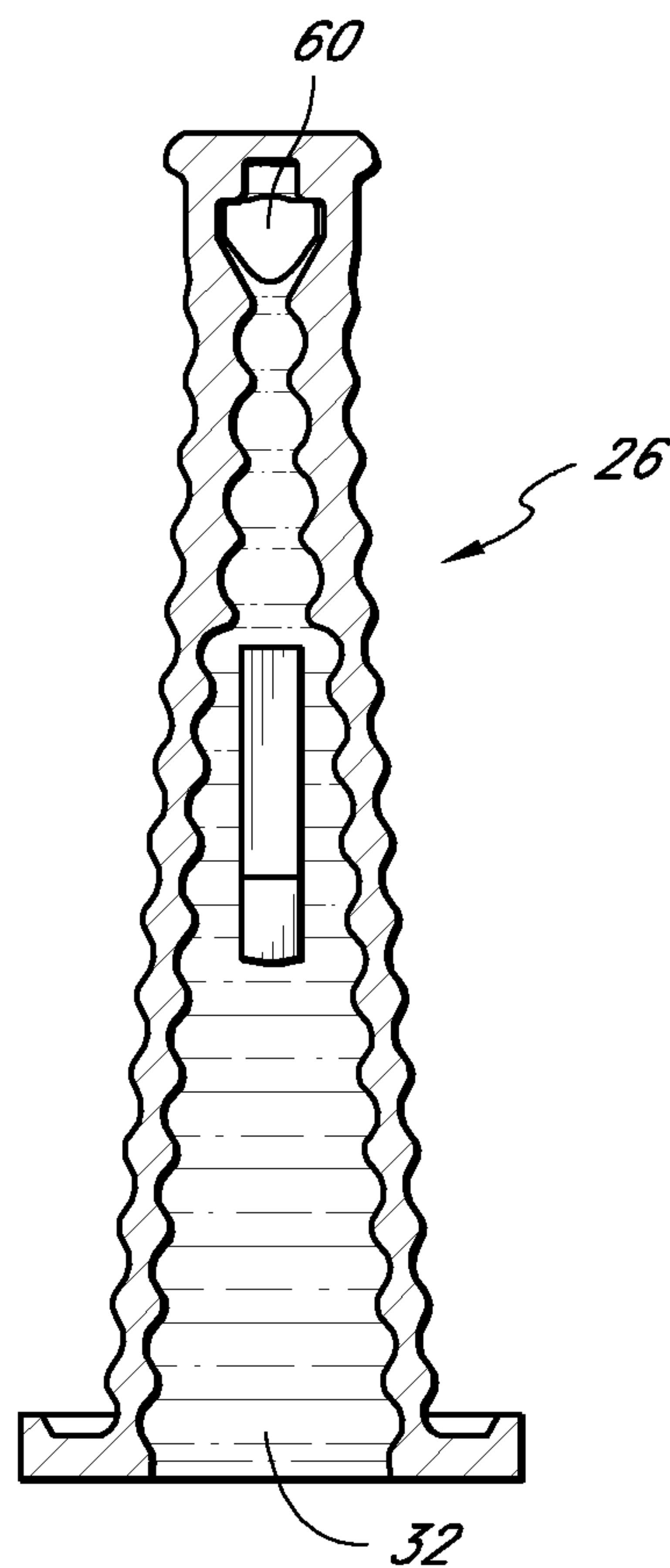

FIG. 7B

7/10

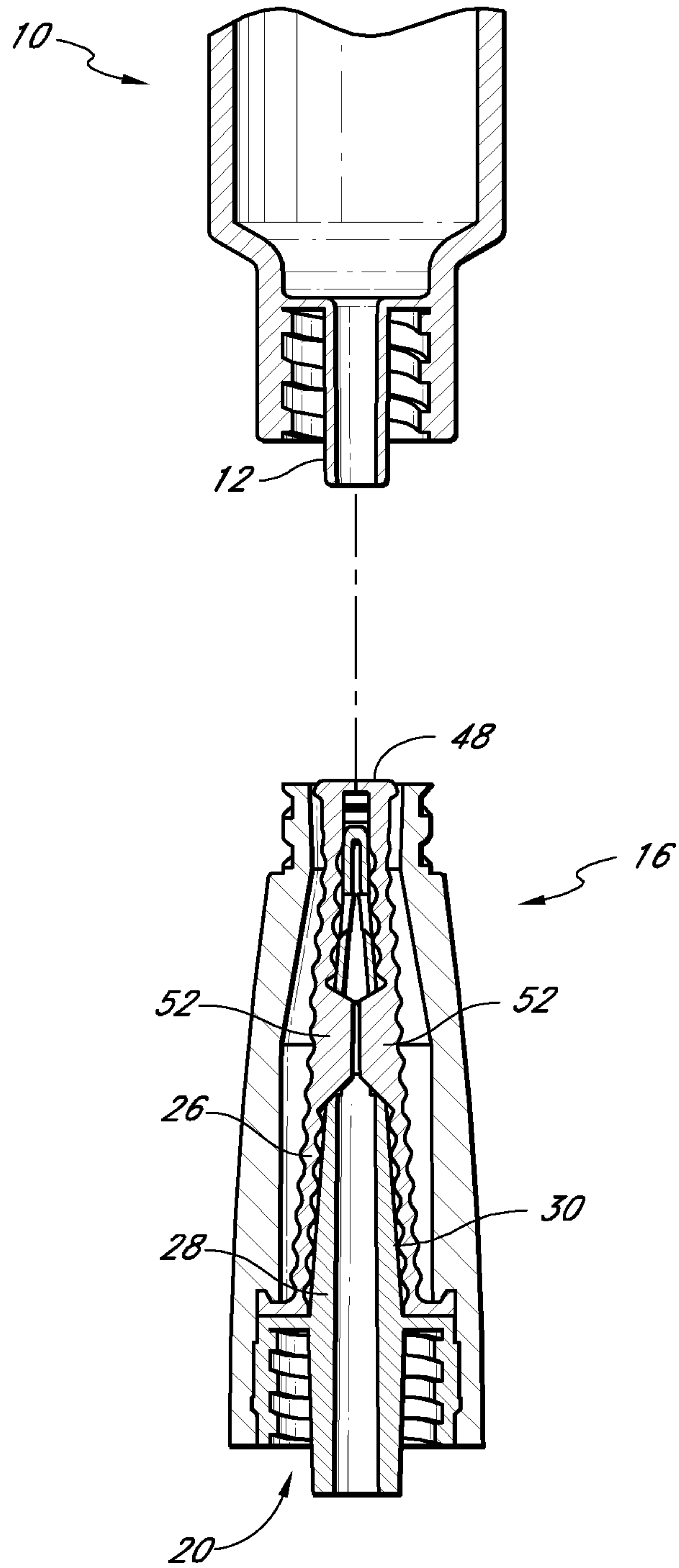

FIG. 8A

8/10

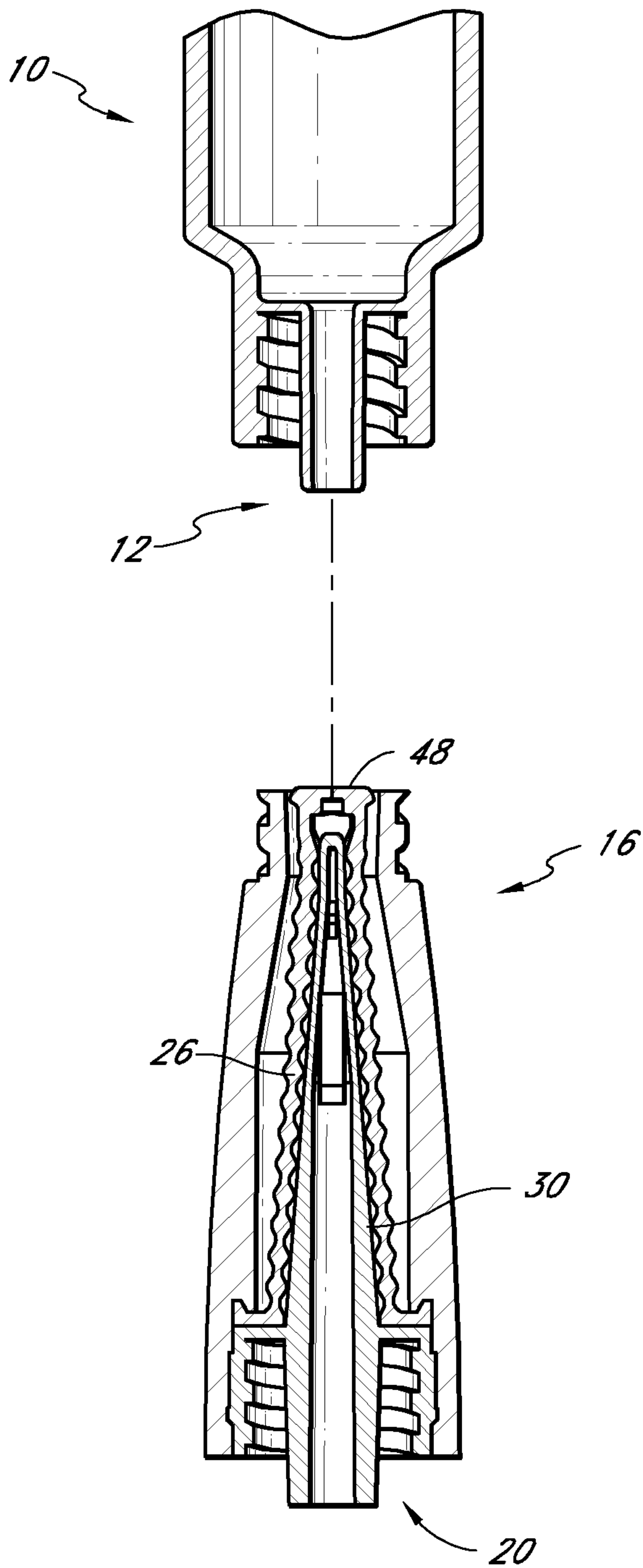

FIG. 8B

9/10

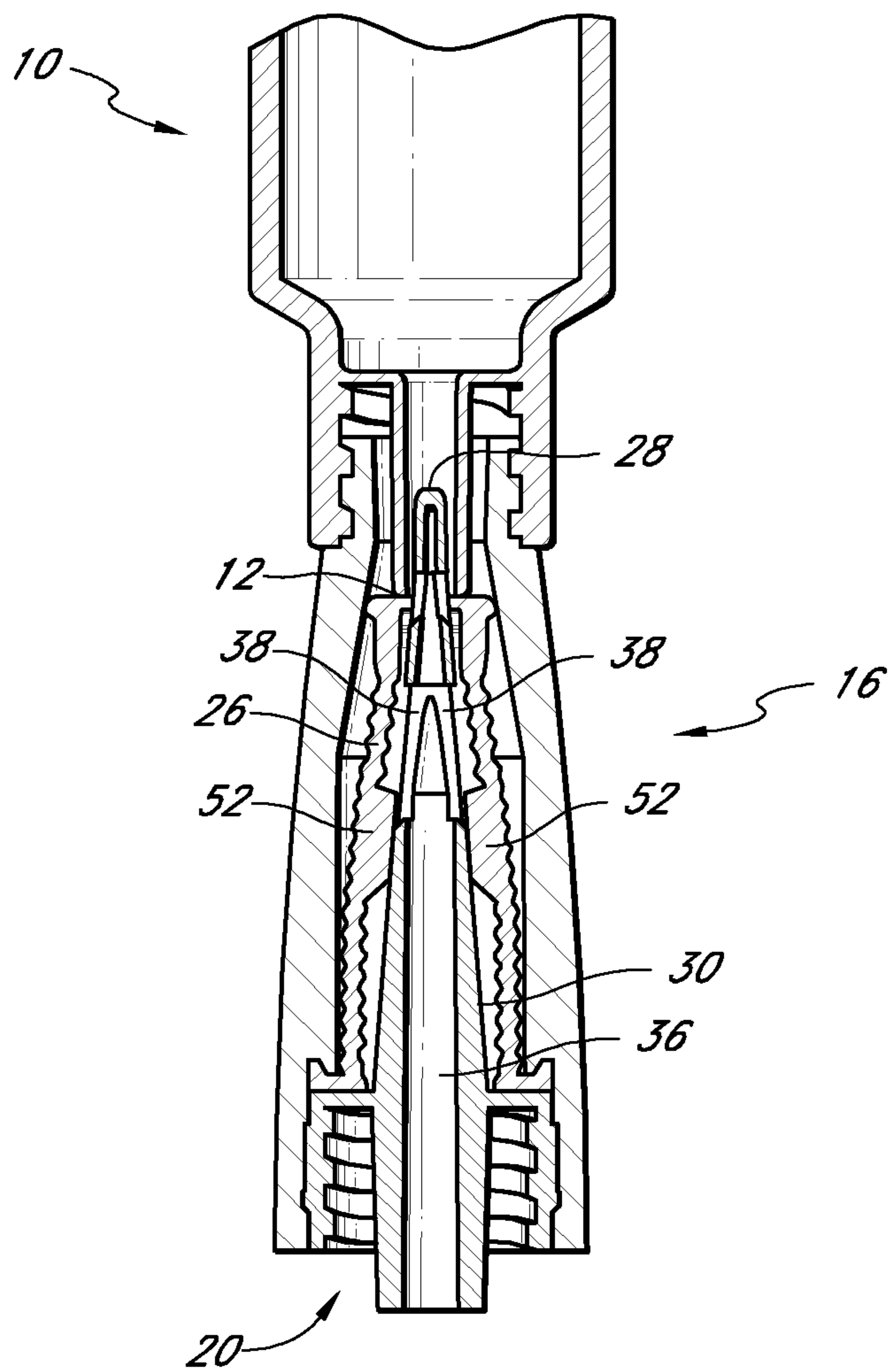

FIG. 9A

10/10

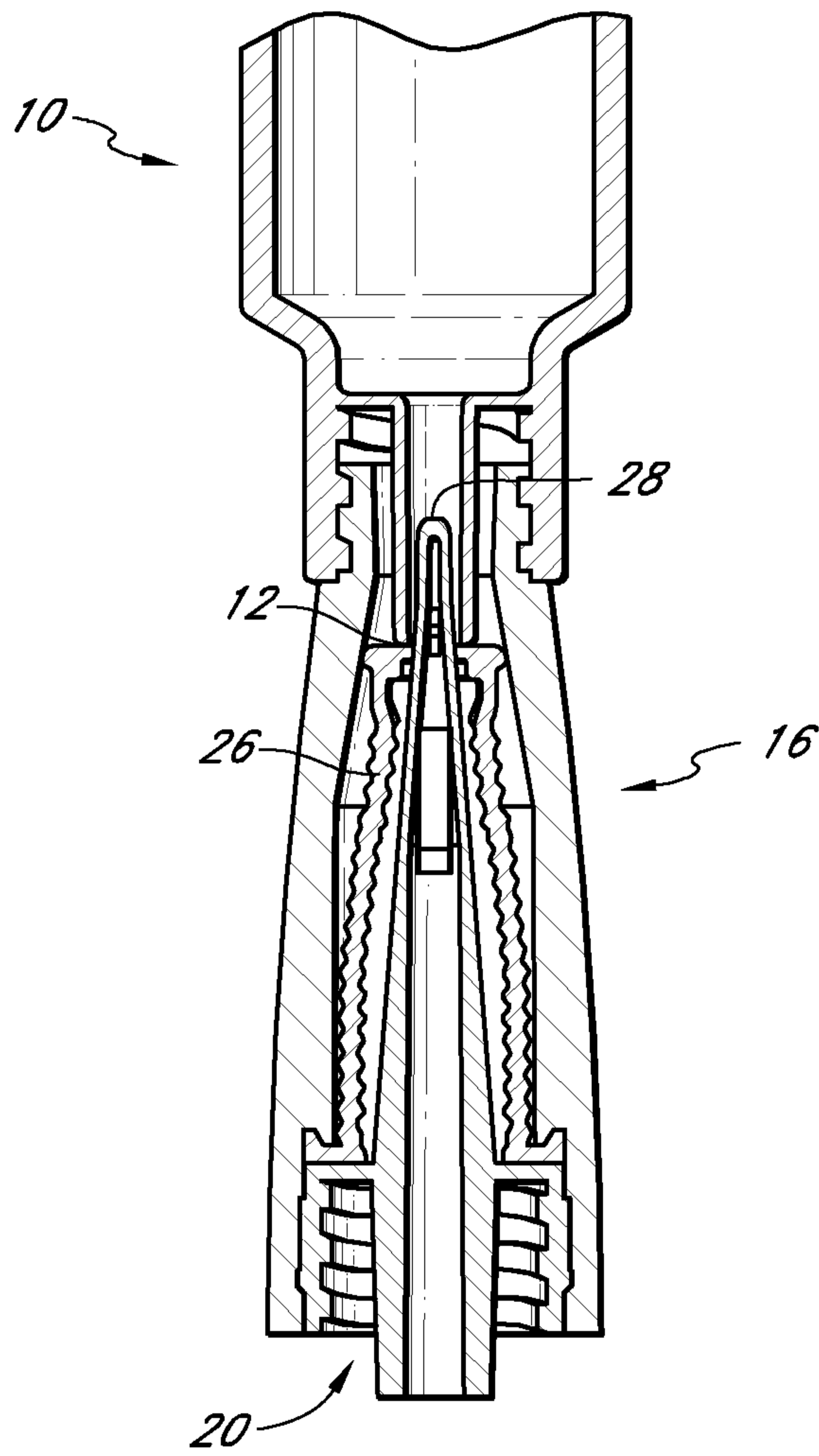

FIG. 9B

