

G. MERRIMAN.
DRIER.

APPLICATION FILED SEPT. 23, 1914.

1,146,894.

Patented July 20, 1915.

2 SHEETS—SHEET 1.

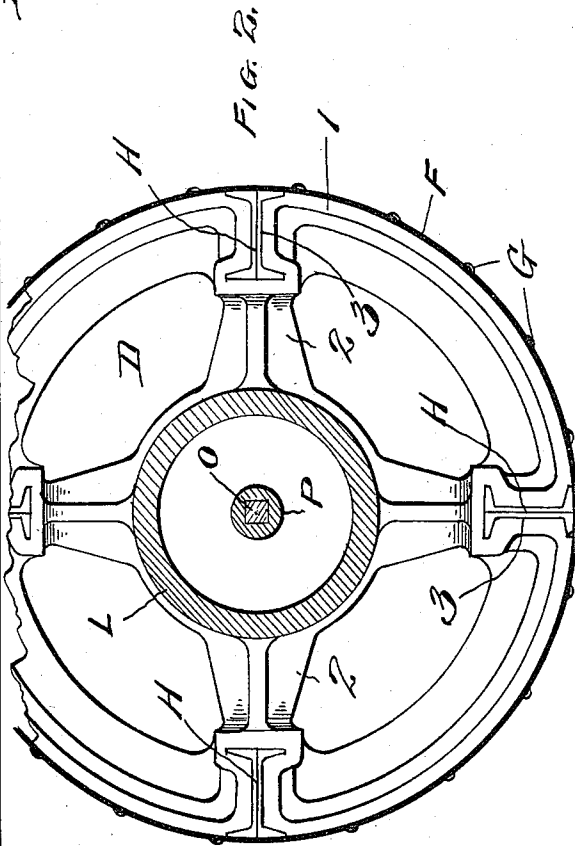
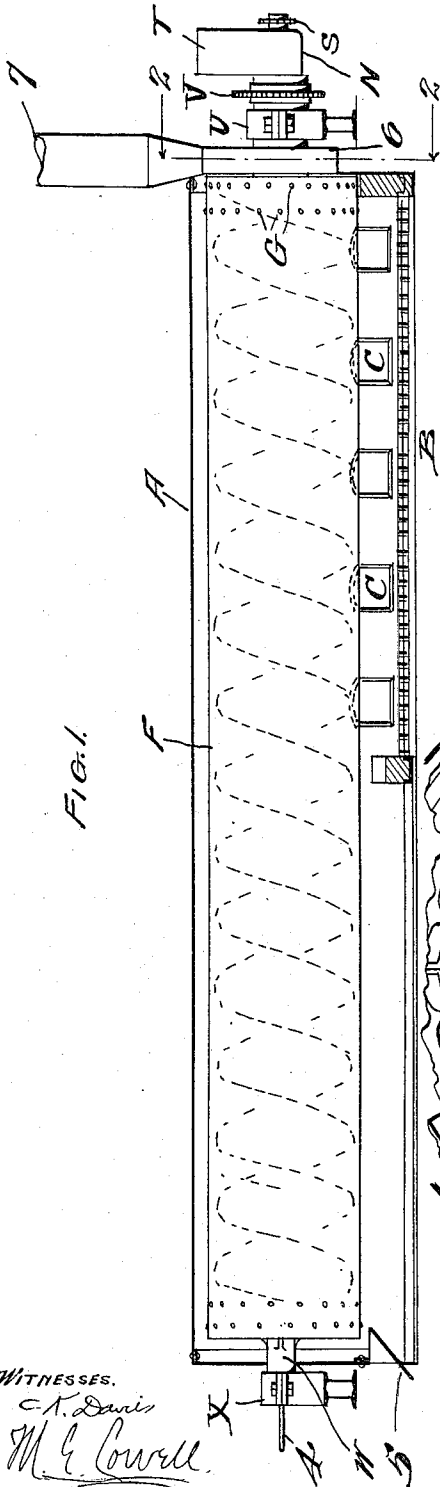

WITNESSES.
C. A. Davis
M. E. Cowell

INVENTOR.

George Merriman,
By J. E. Stebbins,

Attorney.

G. MERRIMAN.
DRIER.

APPLICATION FILED SEPT. 23, 1914.

1,146,894.

Patented July 20, 1915.

2 SHEETS—SHEET 2.

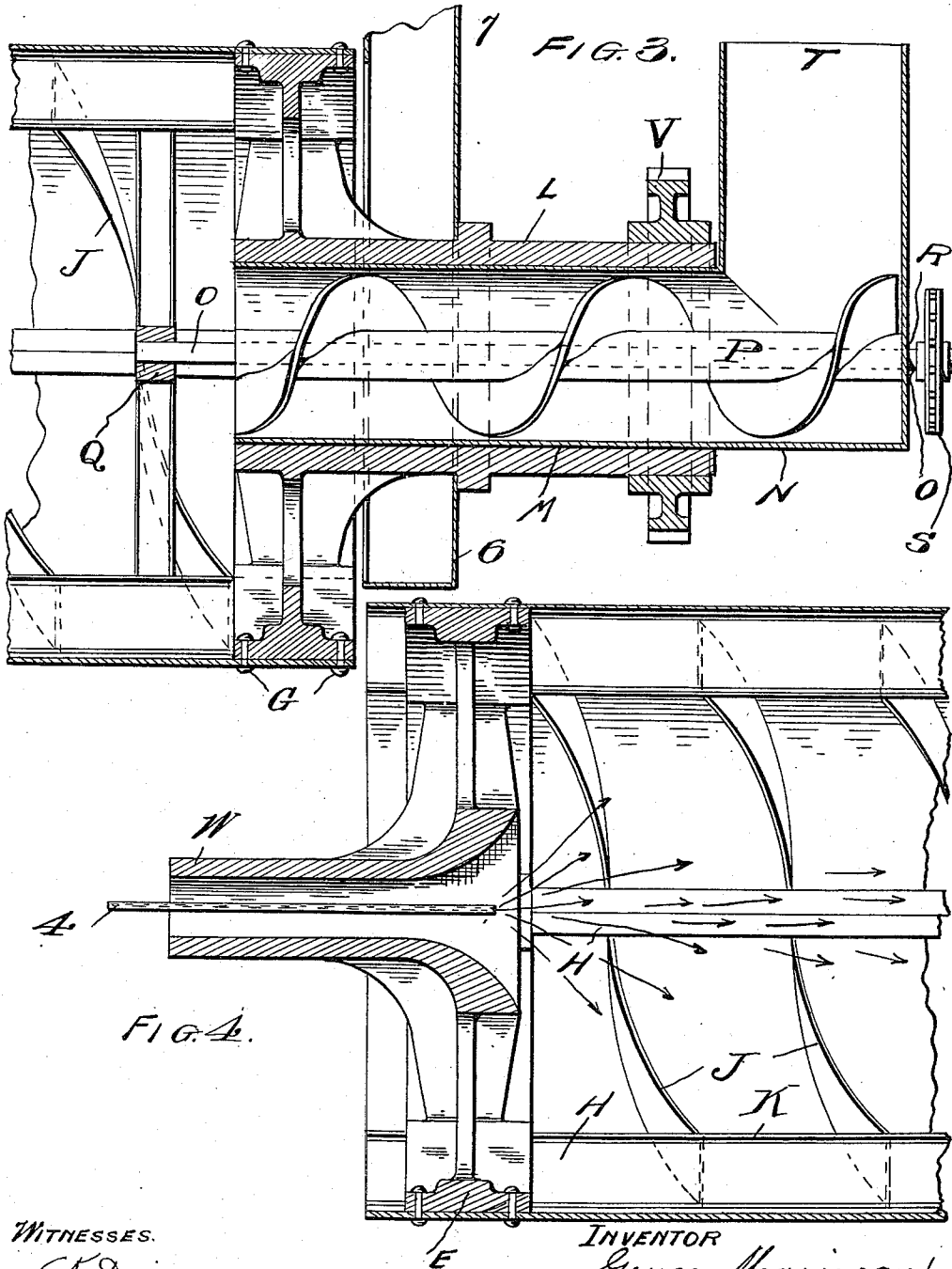

WITNESSES.
C. K. Davis
M. L. Lowell

INVENTOR
George Merriman,
By *F. E. Stebbins*
Attorney.

UNITED STATES PATENT OFFICE.

GEORGE MERRIMAN, OF TOLEDO, OHIO.

DRIER.

1,146,894.

Specification of Letters Patent.

Patented July 20, 1915.

Application filed September 23, 1914. Serial No. 863,137.

To all whom it may concern:

Be it known that I, GEORGE MERRIMAN, a citizen of the United States, residing at Toledo, in the county of Lucas and State of Ohio, have invented certain new and useful Improvements in Driers, of which the following is a specification.

The object of the invention is the provision of a drier of relative small dimensions, especially adapted for use on a one car asphalt plant for drying sand, stone or gravel, whereby the space occupied will not be excessive, and which shall be so constructed and arranged that heat can be applied to the exterior surface and also to the interior of the drier through which the sand is caused to pass.

The invention consists in certain novelties of construction and combinations of parts as herein set forth and claimed.

The accompanying drawings illustrate an example of the embodiment of the invention constructed according to the best mode of procedure I have so far devised for the purpose.

Figure 1 is a side view showing in elevation the rotatory drum and in section the fire box inclosing the drum. Fig. 2 is an enlarged sectional and end view of the trunnion and drum, the section being taken on line 2—2 of Fig. 1. Fig. 3 is an enlarged sectional view in elevation of the drum, trunnion, and gear wheel at the right in Fig. 1. Fig. 4 is an enlarged sectional view of the left hand end of the drum and trunnion.

The fire box A comprises a suitable base with a grate B, sides with a plurality of openings C therein, with doors, through which openings the fuel, such as wood, coal or coke, is applied to the grate, and a metallic top and ends to confine the heat in contact with the exterior surface of the drum.

The rotary drum is comprised of two cast spiders D and E with integral hollow trunnions or shafts. Each spider has a rim 1, spokes 2, slots 3 at the ends of the spokes adjacent to the rim, and a sheet metal cylindrical covering F riveted to the rims of both spiders by rivets G, as shown. Four I beams H, or double channel beams, have their ends located within the slots 3 so their flanges will bear against the interior surface of the sheet metal cylinder F and support the same. Between the webs of the beams H are secured in any suitable way oblique or sections of spirally bent plates J which consti-

tute, when assembled, a complete sand, stone or gravel advancing spiral from end to end of the drum broken only by the interposed I beams. The part of an I beam between the adjacent ends of two plates J forms a spill plate K, that is, the sand, stone or gravel is carried upwardly by the I beam web and flange and spilled over toward the center of the drum as the drum rotates.

The right hand spider D has a hollow trunnion L with a relatively large opening M within which is loosely disposed an elbow-shaped pipe N and within the same is a worm shaft O carrying a worm P, as shown. The worm shaft has an inner bearing Q in a spider carried by the drum, and an outer bearing at R. Outside of the pipe the shaft is provided with a gear wheel or sprocket wheel S which receives power from the engine on the car. The open feed end T of the pipe receives the sand, stone or gravel to be dried and the worm delivers it to the interior of the drum between the spokes. The trunnion L is supported by and rotates in a suitable box U, the power being applied to the gear or sprocket wheel V to rotate the entire drum.

The spider E has a hollow trunnion W supported in a box X outside the end of the fire box, as shown at the left in Fig. 1. Within the hollow trunnion or shaft W is an oil injector burner 4 of any desired species by which heat is applied to the sand on the interior of the drum. Below the trunnion W is a chute 5 through which the dried sand, stone or gravel is discharged from the interior of the drum.

At the right and surrounding the trunnion L is a smoke and gas breeching 6 having an opening facing the open end of the drum, the smoke stack 7 being a continuation of the breeching.

The drier operates as follows: A fire is made in the fire box, the oil injector actuated and the sprayed oil lighted, the drum and feed worm rotated, and sand, stone or gravel delivered to the feed pipe or chute. The sand, stone or gravel advanced by the worm is discharged into the interior of the drum and turned over and over by the spill plates and advanced by the spiral plates to the delivery chute. In passing through the drum the sand, stone or gravel is heated by coming in contact with the exterior wall of the drum heated from the outside, and by the oil fire within the interior. All moisture

is thus evaporated and passes with the exterior and interior products of combustion out of the stack.

Obviously, I have provided a very simple and effective interiorly oil and exteriorly fire box heated drier which occupies but small space and is especially adapted for use as a part of a car asphalt plant.

What I claim is:

1. The combination of a fire box substantially closed, a drier drum located and adapted to be rotated within the fire box, said fire box being adapted for use in applying heat to the exterior surface of the drum, and means for injecting and burning liquid fuel within the interior of the drum while being rotated.

2. The combination of a fire box substantially closed, a drier drum located and adapted to be rotated within the fire box, said fire box being adapted for use in applying heat to the exterior surface of the drum, and means for introducing liquid fuel and burning the same within the interior of the drum comprising a hollow trunnion and an injector extending into said hollow trunnion and in communication with the interior of the drum.

3. A drier drum comprising two spiders with hollow trunnions, flanged beams uniting the spiders, a metallic covering outside the flanged beams and spiders, deflecting plates between the beams, and a spiral conveyer located within one of the trunnions; the conveyer and one of the trunnions each having a gear wheel.

4. A drier drum comprising two spiders each having a rim and a trunnion and one of said trunnions being hollow, flanged beams uniting the spiders, a covering exterior to the flanged beams and secured to the rims of the spiders, and deflecting plates between the beams forming a spiral from end to end of the drum, the said hollow trunnion having a spiral conveyer located within the same.

5. A drier drum comprising two spiders each having a rim and a trunnion and one of said trunnions being hollow, flanged beams uniting the spiders, a covering exterior to the flanged beams and secured to the rims of the spiders, and deflecting plates between the beams forming a spiral from end to end of the drum, the said hollow trunnion having a pipe with an extension inlet chute within the trunnion and a spiral conveyer within the pipe.

6. A drum comprising two spiders each having a hollow trunnion and spokes and slotted rims, flanged beams within the slots in the spiders, a covering secured to the rims exterior to the beams, and deflecting plates between the beams; the trunnions having bearings engaging boxes, and one of said trunnions provided with a gear wheel.

7. A drum comprising two spiders each with a slotted rim, spokes and a trunnion, flanged beams within the slots in the rims, a metallic covering outside the flanged beams and secured to the rims of the spiders, and deflecting plates between the beams arranged to form a spiral from end to end of the drum; the flanged beams when the drum is rotated serving as spill plates.

8. The combination of a substantially closed fire box, a drum located within the fire box and having trunnions projecting outside the fire box, both of said trunnions being hollow, boxes for the trunnions outside the fire box, a gear wheel on one of the trunnions to rotate the drum, a spiral conveyer located within one of the said hollow trunnions for delivering material to the interior of the drum, and an oil injector located in the other hollow trunnion.

In testimony whereof I affix my signature in presence of two witnesses.

GEORGE MERRIMAN.

Witnesses:

SOL. D. TUCKER,
GUS MUNZESHEIMER.