

(No Model.)

S. T. WILLIAMS.  
HOUSING FOR ROLLING MILLS.

No. 522,641.

Patented July 10, 1894.

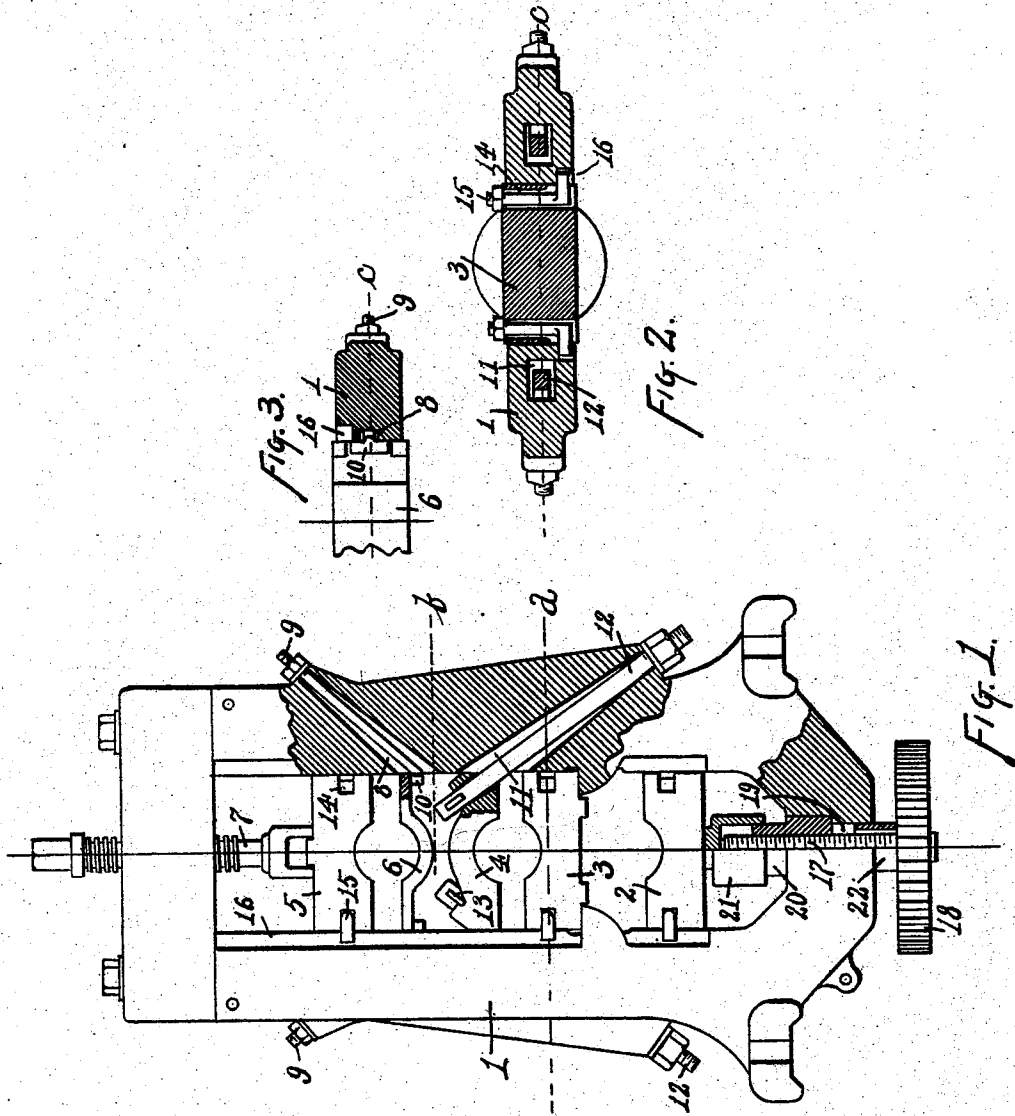

WITNESSES:  
P. P. Sheehan.  
Louise Conboy.

Samuel J. Williams  
INVENTOR.  
By James W. See.  
ATTORNEY.

# UNITED STATES PATENT OFFICE.

SAMUEL T. WILLIAMS, OF MUSCATINE, IOWA.

## HOUSING FOR ROLLING-MILLS.

SPECIFICATION forming part of Letters Patent No. 522,641, dated July 10, 1894.

Application filed July 27, 1893. Serial No. 481,676. (No model.)

### *To all whom it may concern:*

Be it known that I, SAMUEL T. WILLIAMS, of Muscatine, Muscatine county, Iowa, have invented certain new and useful Improvements in Rolling-Mill Housings, of which the following is a specification.

This invention pertains to improvements in housings for rolling-mills and relates to the means for carrying and holding down the rolls, for adjusting the roll-boxes lengthwise of the rolls, and for protecting the lower screw.

My improvements will be readily understood from the following description taken in connection with the accompanying drawings, in which—

Figure 1, is an elevation of the inner face of a rolling-mill housing exemplifying my improvements, portions appearing in vertical section in the plane of line "c" of Figs. 2 and 3; Fig. 2, a sectional plan of the same in the plane of line "a" of Fig. 1; and Fig. 3, a section in the plane of line "b" of Fig. 1, viewed upwardly.

In the drawings:—1, indicates the housing proper, whose general form is as usual: 2, the lower roll-box: 3, the intermediate roll-box: 4, strap for the intermediate roll-box: 5, top roll-box: 6, strap for the top roll-box: 7, top screw: 8, holes through the cheeks of the housing, extending from the inner faces of the housing-cheeks, at about the level of strap 6, diagonally upward: 9, bolts extending through the holes 8 and having adjusting nuts upon their upper ends: 10, T-shaped heads upon the lower ends of bolts 9, these heads bearing against the inner faces of the housing cheeks and coming up against the under surface of strap 6, the holes for the bolts 9 being enlarged at their lower ends so as to permit the bolts to swing: 11, holes through the housing cheeks, extending from about the level of strap 4 diagonally downward: 12, bolts disposed in these holes and having adjusting nuts on their lower ends, the upper ends of the bolts projecting through the wings of strap 4: 13, cotters through bolts 12 over the strap 4: 14, holes through the roll-boxes horizontally, near to and parallel with the inner faces of the housing cheeks: 15, hook-bolts in these holes in the boxes, the hooks engaging the inner face of the housing and the other end of the bolts having adjusting nuts

coming against the outer face of the boxes: 16, rabbets upon the inner corners of the housing-cheeks, the hook-bolts 15 engaging the housings at these rabbets: 17, the lower screw of the housing: 18, the usual gear thereon: 19, a vertical hole in the base of the housing, concentric with screw 17, and larger than the screw, and counterbored at its upper end: 20, the screw-box for the lower screw, threaded onto the screw 17 and having its lower end fitting the counterbore in the housing and having its upper end, preferably, of less diameter, this screw-box forming the nut in which the screw works: 21, a cap placed over the upper end of screw 17 and having its bore engaging the upper end of the screw-box, the roof of this cap being pinched between box 2 and the upper end of the screw: and 22, a thimble surrounding the lower portion of the screw, below the screw-box, and projecting up into the hole 19.

Bolts 12 serve in drawing down the strap 4 upon the journal of the intermediate roll. The removal of cotters 13 permits of the ready removal of these bolts and of the strap.

Bolts 9 serve in supporting strap 6 and in thus carrying the top roll and the nuts upon these bolts permit of easy and delicate adjustment. Hook-bolts 15 serve in adjusting the roll-boxes in the housings endwise of the rolls and thus serve in delicately adjusting the rolls endwise. These hook-bolts are easily removed, as are also the roll-boxes.

Cap 21 serves in protecting the upwardly projecting portion of the lower screw from the dirt to which it is exposed at this point. Thimble 22 protects the lower portion of this screw.

I claim as my invention—

1. In a rolling-mill housing, the combination, substantially as set forth, with the housing, and roll-boxes and straps mounted to slide and be guided vertically therein, of diagonally arranged bolts extending through the housing-cheeks and engaging under one of the straps and provided with adjusting nuts at their upper ends, and serving to rigidly support such strap.

2. In a rolling-mill housing, the combination, substantially as set forth, with the housing, and the roll-boxes and straps mounted to slide and be guided vertically therein, of

bolts passing diagonally through the cheeks of the housing and engaging with their inner upper ends over one of the straps and provided at their lower ends with adjusting nuts, and serving to prevent the rising of such strap in its guide in the housing.

3. In a rolling-mill housing, the combination, substantially as set forth, with the housing, and the roll-boxes and straps mounted to slide and be guided vertically therein, of bolts disposed diagonally through the cheeks of the housing and through one of said straps and having adjusting nuts on their outer lower ends, and cotters through the inner upper ends of said bolts over one of said straps.

4. In a rolling-mill housing, the combination, substantially as set forth, with the housing and roll-boxes mounted therein, of hook-bolts passing horizontally through the roll-boxes and having their hooks engaging one face of the housing and provided upon their other ends with adjusting nuts seating against the roll-boxes.

5. In a rolling-mill housing, the combination, substantially as set forth, with the housing and the roll-boxes mounted therein, of a screw mounted in the housing under the

lower roll-box, a cap surrounding the upper end of the screw and having its roof pinched between the screw and the lower roll-box, and a boss or hub mounted in the housing concentric with the screw and projecting up into said cap around the screw.

6. In a rolling-mill housing, the combination, substantially as set forth, with the housing and the lower boxes mounted therein, of a screw mounted in the housing under the lower roll-box, and a thimble surrounding the screw below the housing and projecting up into a recess in the housing around the screw.

7. The combination, substantially as set forth, of a rolling-mill housing provided in its base with a hole counterbored at its upper end, a screw-box seated in said counterbore and projecting upwardly therefrom, a screw threaded into the screw-box and projecting upwardly through the same, and a cap disposed over the upper end of the screw and having its wall encircling the upwardly projecting portion of the screw-box.

SAMUEL T. WILLIAMS.

Witnesses:

W. H. THOMPSON,  
HOWARD K. WILLIAMS.