

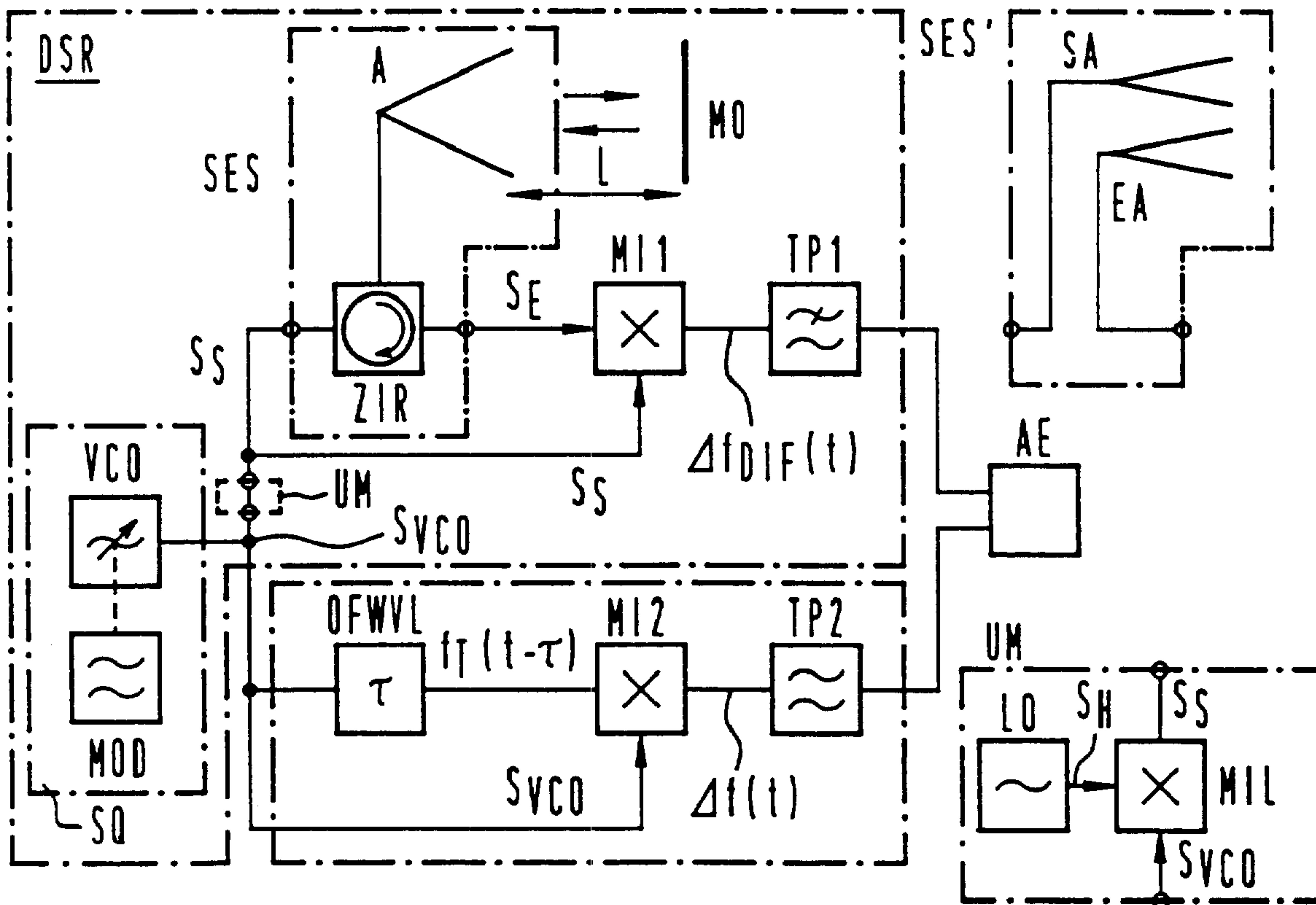

(86) Date de dépôt PCT/PCT Filing Date: 1996/09/06
 (87) Date publication PCT/PCT Publication Date: 1997/03/13
 (45) Date de délivrance/Issue Date: 2001/08/07
 (85) Entrée phase nationale/National Entry: 1998/03/05
 (86) N° demande PCT/PCT Application No.: DE 96/01673
 (87) N° publication PCT/PCT Publication No.: WO 97/09637
 (30) Priorité/Priority: 1995/09/07 (195 33 124.9) DE

(51) Cl.Int.⁶/Int.Cl.⁶ G01S 13/08, G01S 13/34
 (72) Inventeur/Inventor:
MAGORI, Valentin, DE
 (73) Propriétaire/Owner:
SIEMENS AKTIENGESELLSCHAFT, DE
 (74) Agent: FETHERSTONHAUGH & CO.

(54) Titre : DISPOSITIF DE TELEMETRIE
 (54) Title: APPARATUS FOR DISTANCE MEASUREMENT



(57) Abrégé/Abstract:

A distance measuring device wherein a reference unit is juxtaposed with a continuous wave radar. The reference unit comprises a surface wave element for generating a signal delayed relative to the transmission signal. A mixed signal is formed from the delayed signal and the transmission signal with a mixer, this mixed signal being utilized in combination with the measured signal stemming from the continuous wave radar for determining the distance.

ABSTRACT

A distance measuring device wherein a reference unit is juxtaposed with a continuous wave radar. The reference unit comprises a surface wave element for generating a signal delayed relative to the transmission signal. A mixed signal is formed from the delayed signal and the transmission signal with a mixer, this mixed signal being utilized in combination with the measured signal stemming from the continuous wave radar for determining the distance.

APPARATUS FOR DISTANCE MEASUREMENT

Background of the InventionField of the Invention

The present invention is directed generally to the field of an apparatus for distance measurement. More specifically, the present invention is directed to a radar distance measuring device.

A continuous wave radar, which is also referred to as FMCW radar is known from the Prior Art of Meinke, Gundlach, Taschenbuch der Hochfrequenztechnik, 5th Edition, Springer-Verlag, Chapter S 3. The abbreviation FM stands for frequency modulation and CW stands for continuous wave. Figure 1 shows such a continuous wave radar. A modulator MOD generates a modulating signal that is supplied to a voltage-controlled oscillator VCO. An optimally linearly frequency-modulated signal should be adjacent at the output of the voltage-controlled oscillator VCO. Insofar as the frequency-voltage characteristic of the voltage-controlled oscillator VCO exhibits a non-linearity, referenced NLIN in the f-u diagram, the modulating signal stemming from the modulator MOD is to be correspondingly pre-distorted, as indicated with the signal curve VNLIN in the u-t diagram of the modulator MOD. When the voltage-controlled oscillator VCO exhibits a linear characteristic LIN, a linear characteristic is to be selected for the modulator MOD. The linearly frequency-modulated signal stemming from the voltage-controlled oscillator VCO is conducted over a circulator ZIR and beamed out by an antenna A.

The beamed-out signal is reflected by a test subject MO located at the distance I from the antenna A and is received by the antenna A. This received signal passes via the circulator ZIR onto a mixer MI that mixes this received signal with the transmission signal present at the moment. The difference frequency $\Delta f_{DIF}(t)$ is a measure for the distance L of the test subject MO from the antenna A. Measuring errors arise, however, when the frequency-modulated transmission signal derived from the voltage-controlled oscillator does not exhibit a linear f-t characteristic.

10

A correction of the non-linearity of the f-u characteristic of the voltage-controlled oscillator VCO is not always possible or involves a high outlay of equipment.

An object of the invention is to provide an apparatus for distance measurement wherein a potential non-linearity in the frequency-modulated output signal of the voltage-controlled oscillator is present without influencing the measuring precision.

When the isolation of the circulator is too low, a further antenna can be provided that provides for the reception of the reflected signal.

20

When transmission power is to be prevented from also being adjacent at the mixer, a circulator can be connected between the signal source, the mixer and the antenna.

Another aspect of the invention has the advantage that a major part of the sensor components can be operated in a lower-frequency range with reference to the transmission frequency. This is more flexible in practice.

20365-3811

Yet another aspect of the invention likewise serves for improved manipulation when the signal source generates a signal whose frequency is higher than the frequency at which the signal processing should take place.

5 A further aspect of the invention serves for the suppression of noise sources. Additionally, adjacent apparatus for distance measurement can be distinguished from one another with this development.

In accordance with the present invention, there is
10 provided an apparatus for distance measurement, comprising: a signal source for generating a frequency-modulated signal; a transmission/reception stage and a first mixer; the first mixer connected to the transmission/-reception stage and to the signal source; a reference unit comprising a surface wave
15 element and a second mixer for delaying the signal coming from the signal source and mixing it with an undelayed signal; an evaluation unit receives the signal formed by the mixers; and wherein the evaluation unit a) determines frequency
characteristics of the signal from the second mixer from said
20 signal dependent on the time for arbitrarily prescribed test subject distances, and b) determines the test subject distance with best coincidence by a comparison of these frequency characteristics to a signal from the first mixer by correlation of evaluation according to the least error square.

25 In accordance with the present invention, there is provided an apparatus for distance measurement, comprising: a signal source for generating a frequency-modulated signal; a transmission/reception stage and a first mixer; the first mixer arranged for mixing a signal coming from the
30 transmission/reception stage with the signal generated by the signal source; a reference unit comprising a surface wave

20365-3811

element and a second mixer for delaying the signal from the signal source in terms of time and mixing it with the undelayed signal; an evaluation unit arranged to receive signals formed by the mixers and wherein the evaluation unit is configured for

5 a) sampling a signal from the first mixer at points in time of specific phase angles of the signal from the second mixer to provide sampled values, b) digitizing the sampled values and storing them with identification of the points in time of the occurrence of the respective samples, and c) acquiring a signal

10 that would have resulted from a linear frequency modulation, acquiring said signal by reading out the values with a constant clock rate.

In accordance with the present invention, there is provided an apparatus for distance measurement, comprising: a

15 signal source for generating a frequency-modulated signal; a transmission/reception stage and a first mixer; the first mixer connected to the transmission/reception stage and to the signal source; a reference unit comprising a surface wave element and a second mixer for delaying the signal coming from the signal

20 source in terms of time and mixing it with the undelayed signal; an evaluation unit arranged to receive the signals formed by the mixers; and wherein the evaluation unit is configured for a) acquiring and storing the signals from the mixers with a constant sampling rate; b) calculating points in

25 time with predetermined phase angles of the signal from the second mixer; c) determining the corresponding values of the signal from the first mixer at the points in time; and d) acquiring a further signal that would have resulted from a linear frequency modulation, acquiring said further signal by

30 reading out the values with a constant clock rate.

In accordance with the present invention a method for distance measurement comprising the steps of: generating a

20365-3811

frequency-modulated signal; transmitting the generated signal and receiving a part of the signal reflected by a test subject; mixing the received signal with the generated signal to form a measured signal; mixing the generated signal with a signal
5 delayed in time relative thereto to form a reference signal; determining a frequency characteristic of the reference signal dependent on the time for arbitrarily prescribed test subject distances; and comparing the frequency characteristics to a measured signal and determining the test subject distance of
10 best coincidence by correlation or evaluation according to the least square error.

In accordance with the present invention a method for distance measurement comprising the steps of: generating a frequency-modulated signal; transmitting the generated signal
15 and receiving a part of the signal reflected by a test subject; mixing the received signal with the generated signal to form a measured signal; mixing the generated signal with a signal delayed in time relative thereto to form a reference signal; sampling a measured signal at points in time of specific phase
20 angles of the reference signal; digitizing the sampled values and storing the values together with the points in time of the occurrence of the samples; and acquiring a signal that would have resulted for a linear frequency modulation by readout of the values with a constant clock rate.

25 In accordance with the present invention a method for distance measurement comprising the steps: generating a frequency-modulated signal; transmitting the generated signal and receiving a part of the signal reflected by a test subject; mixing the received signal with the generated signal to form a
30 measured signal; mixing the generated signal with a signal delayed in time relative thereto to form a reference signal; acquiring the measured signal and the reference signal with a

20365-3811

constant sampling rate and storing the measured and reference signals; calculating points in time of predetermined phase angles of the reference signal; determining the corresponding values of the measured signal at these points in time; and
 5 acquiring a further signal that would have resulted for a linear frequency modulation by readout of the values with a constant clock rate.

Brief Description of the Drawings

The invention is explained in greater detail below
 10 with reference to the Figures wherein

Figure 1 illustrates a continuous wave radar as known from the Prior Art;

Figure 2 illustrates the basic structure of the inventive apparatus for distance measurement;

15 Figure 3 illustrates a further embodiment of the inventive apparatus for distance measurement.

Detailed Description of the Preferred Embodiments

According to Figure 2, the inventive apparatus for distance measurement comprises a signal source SQ that contains
 20 a modulator MOD and a voltage-controlled oscillator VCO. The voltage-controlled oscillator VCO generates a not necessarily linearly frequency-modulated signal S_{VCO} with the frequency

$f_{VCO}(t)$:

$$f_{VCO}(t) = f_c + \dot{\omega} \cdot t$$

25 linear tuning having the characteristic

$$\dot{\omega} = \frac{\Delta f_c}{T} \quad \text{for } 0 < t < T$$

whereby

f_c = carrier frequency

$\dot{\omega}$ = variation of the frequency dependent on the time

Δf_c = frequency shift

T = period of a tuning event.

The converter UM shown at the lower right in Figure 2 is not subsequently used. Therefore the following is: The transmission signal S_S with the momentary frequency $f_T(t)$ that is adjacent at the input of the circular ZIR is the same as the signal with the frequency $f_{VCO}(t)$, i. e.: $f_T(t) = f_{VCO}(t)$ and $S_{VCO} = S_S$. This frequency-modulated signal with the momentary frequency $f_T(t)$ is adjacent at a transmission/-reception unit SES that comprises the circulator ZIR and an antenna A. The signal beamed out by the antenna A and reflected at the test subject MO is received by the antenna A and conducted to a first mixer MI1 via the circulator ZIR. The transmission signal S_S with the momentary frequency $f_T(t)$ is additionally adjacent at this first mixer MI1. The difference frequency $\Delta f_{DIF}(t)$ formed by the first mixer MI1 from the two frequencies $f_T(t-t_L)$ and $f_T(t)$ is supplied to an evaluation unit AE via a first low-pass filter TPl. A reference unit REF, also referred to as reference branch, is juxtaposed with this unit referred to as continuous wave radar DSR or as measuring branch, as well. The reference unit REF is supplied with the frequency-modulated signal S_{VCO} having the momentary frequency

$f_T(t)$ ($=f_{VCO}(t)$) that is generated by the voltage-controlled oscillator VCO. The reference unit REF comprises a surface wave element OFW that forwards the frequency-modulated signal to a second mixer MI2 delayed by the time duration τ . This forms the difference frequency $\Delta f(t)$ from the two frequencies $f_T(t-T)$ and $f_T(t)$. The difference frequency $\Delta f_{DIF}(t)$ that stems from the continuous wave radar as well as the difference frequency $\Delta f(t)$ that stems from the reference unit REF are both conducted to the evaluation unit AE. The phase shift ϕ_{DSR} at the output of the continuous wave radar DSR derives as:

$$\phi_{DSR}(t) = \frac{t_L \cdot \Delta f_{DIF}(t)}{2\pi} \quad (1)$$

whereby

t_L = signal running time on the measuring path.

The phase shift ϕ_{REF} at the output of the reference unit REF derives as

$$\phi_{REF}(t) = \tau \cdot \frac{\Delta f(t)}{2\pi} \quad (2)$$

whereby

τ = delay duration of the delay line.

The following relationships exist between the signals in the reference branch REF and the signals in the measuring branch DSR:

The delay duration τ referred to the difference frequency $\Delta f(t)$ at the output of the second mixer MI2 is equal to the signal running time t_L referred to the difference

frequency $\Delta f_{DIF}(t)$ at the output of the first mixer MI1.

Accordingly, the signal running time t_L derives as:

$$t_L = \frac{\phi_{DSR}(t)}{\phi_{REF}(t)} \cdot \tau \quad (3)$$

The signal running time t_L on the measuring path derives from the measured phase curves on the measuring branch DSR and on the reference branch REF and from the exactly known delay duration τ of the surface wave element OFW. This relationship can be interpreted by microprocessors, particularly digital signal processors, in the evaluation unit AE. This interpretation can take place in various ways:

1st Possibility:

Based on the signal from the second mixer MI2 with the difference frequency $\Delta f(t)$ between input and output signal of the reference branch, the frequency characteristic thereof can be determined dependent on the time. Since the curve of the signal stemming from the first mixer MI1 with the difference frequency $\Delta f_{DIF}(t)$ follows the same characteristic, a mixed signal for an arbitrarily variable test subject distance L can thus be synthesized. That distance L for which the best coincidence between the signals derived can be found by a comparison of the signals calculated in this way with that of the measuring path on the basis of correlation or evaluation according to the least error square between the two signals. This means that the actual subject distance corresponds to the value for the distance L given best coincidence.

A coincidence or, respectively, a best similarity for a plurality of distances derived given a plurality of detected subjects.

2nd Possibility:

When tuning (sweeping) the signal source SQ, a quasi-periodic with many periods (given a long delay duration τ) is present in the reference branch REF as a signal with the difference frequency $\Delta f(t)$. Sampling pulses are generated from this signal at specific phase angles (preferably zero-axis crossings), these sampling pulses determine the points in time at which the signal with the difference frequency $\Delta f_{DIF}(t)$ stemming from the measuring branch DSR is sampled. The sampled values are digitized and loaded into a memory together with the points in time of the occurrence of the samples. The same signal curve derives as memory content that would have derived with a constant sampling or read-in rate given time-linear frequency modulation. Given readout of the memory with a constant clock rate, accordingly, a signal results that would also have been derived from a linear frequency modulation (FM).

Given an analog storing, for example in a bucket brigade memory, an analogous procedure would lead to analogous results.

3rd Possibility:

The measured as well as the reference signal can, further, be read into a memory with a constant sampling rate. Points in time with predetermined phase angles (preferably zero-axis crossings, i. e. 180°) are calculated from the stored

reference signal. The corresponding values of the measured values are read out at exactly these points in time. When these values are read out with a constant clock rate, then a signal as would result from exactly linear frequency modulation is calculated.

The further processing of the signals obtained in this way can then also be implemented with those methods that are employed for the processing of the signals given an exactly linearly frequency modulated signal source SQ.

10 A converter UM, as shown at the lower right in Figure 2, can be inserted at the location referenced UM at the left in Figure 2. The converter UM comprises a local oscillator LO that generates a signal S_H with a frequency f_H that is higher than the frequency $f_{VCO}(t)$ that stems from the voltage-controlled oscillator VCO. This signal S_H with the frequency $f_H(t)$ is stepped up at a mixer MIL with the signal stemming from the voltage-controlled oscillator VCO. The reception signal is stepped down homodyne into the base band with the transmission signal. The reference branch REF is operated at
20 the intermediate frequency at which the voltage-controlled oscillator VCO generates the frequency-modulated signal with the frequency $f_{VCO}(t)$.

Both a monostatic arrangement SES as well as a bistatic antenna arrangement SES' can be employed for the transmission/reception stage SES of the measuring branch DSR. Given the monostatic arrangement SES, the transmission signal and the reception signal are separated by the circulator ZIR

or by a directional coupler following the common transmission and reception antenna SA. In the bistatic antenna arrangement SES' a transmission antenna SA and a reception antenna EA are provided.

Insofar as the sampling of the measured signal ensues at every zero point of the reference signal, the delay duration τ for both the direct sampling as well as for the computational sampling must be at least as long as the signal running time t_L in order to satisfy the sampling theorem of Shannon.

10 When other evaluation methods are selected, the delay duration τ can also be shorter than the maximum signal running time t_L .

When only a real signal is needed, the mixers shown in Figure 2 can be implemented as simple mixers. When a complex signal is needed, the mixers MI1, MI2 and MI3 in both the measuring branch and in the reference branch can be implemented as IQ mixers.

20 Complex signals can also be computationally acquired with Hilbert transformation from the real time signal. IQ mixers can then be omitted.

The apparatus for distance measurement shown in Figure 3 differs from the apparatus for distance measurement shown in Figure 2 in that the signal source SQ generates a frequency-modulated signal $S_{VCO} = S_S$ with the momentary frequency $f_T(t)$ that is higher in frequency than the frequency $f_{LHF}(t)$ of the signal S_{LHF} stemming from the local oscillator LO2. Specifically, the momentary frequency $f_T(t)$ of the frequency-

modulated signal S_S corresponds to the transmission frequency. The mixers MI4 and MI3 mix the frequency-modulated transmission signal S_S having the momentary frequency $f_T(t)$ or, respectively, reception signal S_E having the momentary frequency $f_T(t-\tau)$ with the signal S_{LHF} down onto a lower frequency $\Delta f_4(t)$ or, respectively, $\Delta f_3(t)$. The frequency $\Delta f_4(t)$ of the signal S_4 at the output of the fourth mixer MI4 is the difference from the momentary frequency $f_T(t)$ and $f_{LHF}(t)$. The difference frequency $\Delta f_3(t)$ of the signal S_3 at the output of the third mixer MI3 is the difference frequency from the frequencies $f_T(t-t_L)$ and $f_{LHF}(t)$.

In the embodiment shown in Figure 3, the transmission/reception stage SES can be replaced by a bistatic transmission/reception stage SES' according to Figure 2. This has the advantage that the attenuation between signal source SQ and mixer MI3 is increased. Further, the transmission power can be increased as a result thereof.

The voltage-controlled oscillator VCO generates the frequency-modulated signal in the output frequency range of the measuring branch DSR. Both the transmission signal as well as the reception signal of the measuring branch DSR are mixed with the same local oscillator LO2 onto the intermediate frequency (ZF) level at which the reference branch REF is also operated.

The mixers MI1 through MI4 can be simple mixers for generating a real signal or can also be IQ mixers for generating a complex signal.

Complex signals can also be computationally acquired from the real time signal by Hilbert transformation.

For a sampling of the measured signal at every zero location of the reference signal, the delay duration τ both the direct sampling as well as for the computational sampling must be at least as long as the signal running time t_L in order to satisfy the sampling theorem.

The evaluation of the measured signal and of the reference signal in the evaluation unit AE can ensue in the same way as described under the first embodiment according to Figure 2.

10 Given the embodiment shown in Figure 3, the average momentary frequency $f_T(t)$ typically lies at 24 GHz. The local oscillator LO2 generates a signal of the frequency $f_{LHF}(t) = 21.5$ GHz. Of course, the arrangement is not limited to these frequencies.

 Problems can arise given simultaneous operation of a plurality of distance measuring apparatus by a plurality of users. When a first distance measuring apparatus emits in the reception range of a second distance measuring apparatus, then this leads to disturbances that also achieve stronger reception
20 levels in the side lobes than the comparatively weak radar echos. An arbitrarily selected, irregular modulation signal curve can be prescribed for suppressing these disturbances.

 Further possibilities for improving the immunity to interference are:

1. The modulation signal stemming from the modulator MOD can be varied according to a fixed pattern.

2. The modulation signal stemming from the modulator

MOD can be varied with the assistance of a random generator.

3. The switching of the curve of the modulating voltage can be undertaken after "negotiation" with the interfering transmitter that itself is likewise interfered with. Suitable functions for different users are those that correlate as slightly as possible with one another.

20365-3811

CLAIMS:

1. An apparatus for distance measurement, comprising:
a signal source for generating a frequency-modulated
signal;
- 5 a transmission/reception stage and a first mixer;
the first mixer connected to the transmission/-
reception stage and to the signal source;
- a reference unit comprising a surface wave element
and a second mixer for delaying the signal coming from the
10 signal source and mixing it with an undelayed signal;
- an evaluation unit receives the signal formed by the
mixers; and
- wherein the evaluation unit a) determines frequency
characteristics of the signal from the second mixer from said
15 signal dependent on the time for arbitrarily prescribed test
subject distances, and b) determines the test subject distance
with best coincidence by a comparison of these frequency
characteristics to a signal from the first mixer by correlation
of evaluation according to the least error square.
- 20 2. An apparatus for distance measurement, comprising:
a signal source for generating a frequency-modulated
signal;
- a transmission/reception stage and a first mixer;
- the first mixer arranged for mixing a signal coming
25 from the transmission/reception stage with the signal generated
by the signal source;

20365-3811

a reference unit comprising a surface wave element and a second mixer for delaying the signal from the signal source in terms of time and mixing it with the undelayed signal;

5 an evaluation unit arranged to receive signals formed by the mixers and

wherein the evaluation unit is configured for a) sampling a signal from the first mixer at points in time of specific phase angles of the signal from the second mixer to
10 provide sampled values, b) digitizing the sampled values and storing them with identification of the points in time of the occurrence of the respective samples, and c) acquiring a signal that would have resulted from a linear frequency modulation, acquiring said signal by reading out the values with a constant
15 clock rate.

3. An apparatus for distance measurement, comprising:

a signal source for generating a frequency-modulated signal;

a transmission/reception stage and a first mixer;

20 the first mixer connected to the transmission/reception stage and to the signal source;

a reference unit comprising a surface wave element and a second mixer for delaying the signal coming from the signal source in terms of time and mixing it with the undelayed
25 signal;

an evaluation unit arranged to receive the signals formed by the mixers; and

20365-3811

wherein the evaluation unit is configured for a) acquiring and storing the signals from the mixers with a constant sampling rate; b) calculating points in time with predetermined phase angles of the signal from the second mixer; 5 c) determining the corresponding values of the signal from the first mixer at the points in time; and d) acquiring a further signal that would have resulted from a linear frequency modulation, acquiring said further signal by reading out the values with a constant clock rate.

10 4. An apparatus according to any one of claims 1 through 3, wherein a local oscillator and further mixer are connected between the signal source and the transmission/reception stage; the local oscillator generates a signal with a frequency that is higher than the frequency from the signal source; and 15 wherein a further mixer is provided for mixing the signal of the signal source with the signal of the local oscillator.

5. A method for distance measurement comprising the steps of:

generating a frequency-modulated signal;

20 transmitting the generated signal and receiving a part of the signal reflected by a test subject;

mixing the received signal with the generated signal to form a measured signal;

25 mixing the generated signal with a signal delayed in time relative thereto to form a reference signal;

determining a frequency characteristic of the reference signal dependent on the time for arbitrarily prescribed test subject distances; and

20365-3811

comparing the frequency characteristics to a measured signal and determining the test subject distance of best coincidence by correlation or evaluation according to the least square error.

5 6. A method for distance measurement comprising the steps of:

generating a frequency-modulated signal;

transmitting the generated signal and receiving a part of the signal reflected by a test subject;

10 mixing the received signal with the generated signal to form a measured signal;

mixing the generated signal with a signal delayed in time relative thereto to form a reference signal;

15 sampling a measured signal at points in time of specific phase angles of the reference signal;

digitizing the sampled values and storing the values together with the points in time of the occurrence of the samples; and

20 acquiring a signal that would have resulted for a linear frequency modulation by readout of the values with a constant clock rate.

7. A method for distance measurement comprising the steps:

generating a frequency-modulated signal;

25 transmitting the generated signal and receiving a part of the signal reflected by a test subject;

20365-3811

mixing the received signal with the generated signal to form a measured signal;

mixing the generated signal with a signal delayed in time relative thereto to form a reference signal;

5 acquiring the measured signal and the reference signal with a constant sampling rate and storing the measured and reference signals;

calculating points in time of predetermined phase angles of the reference signal;

10 determining the corresponding values of the measured signal at these points in time; and

acquiring a further signal that would have resulted for a linear frequency modulation by readout of the values with a constant clock rate.

FETHERSTONHAUGH & CO.

OTTAWA, CANADA

PATENT AGENTS

FIG 1

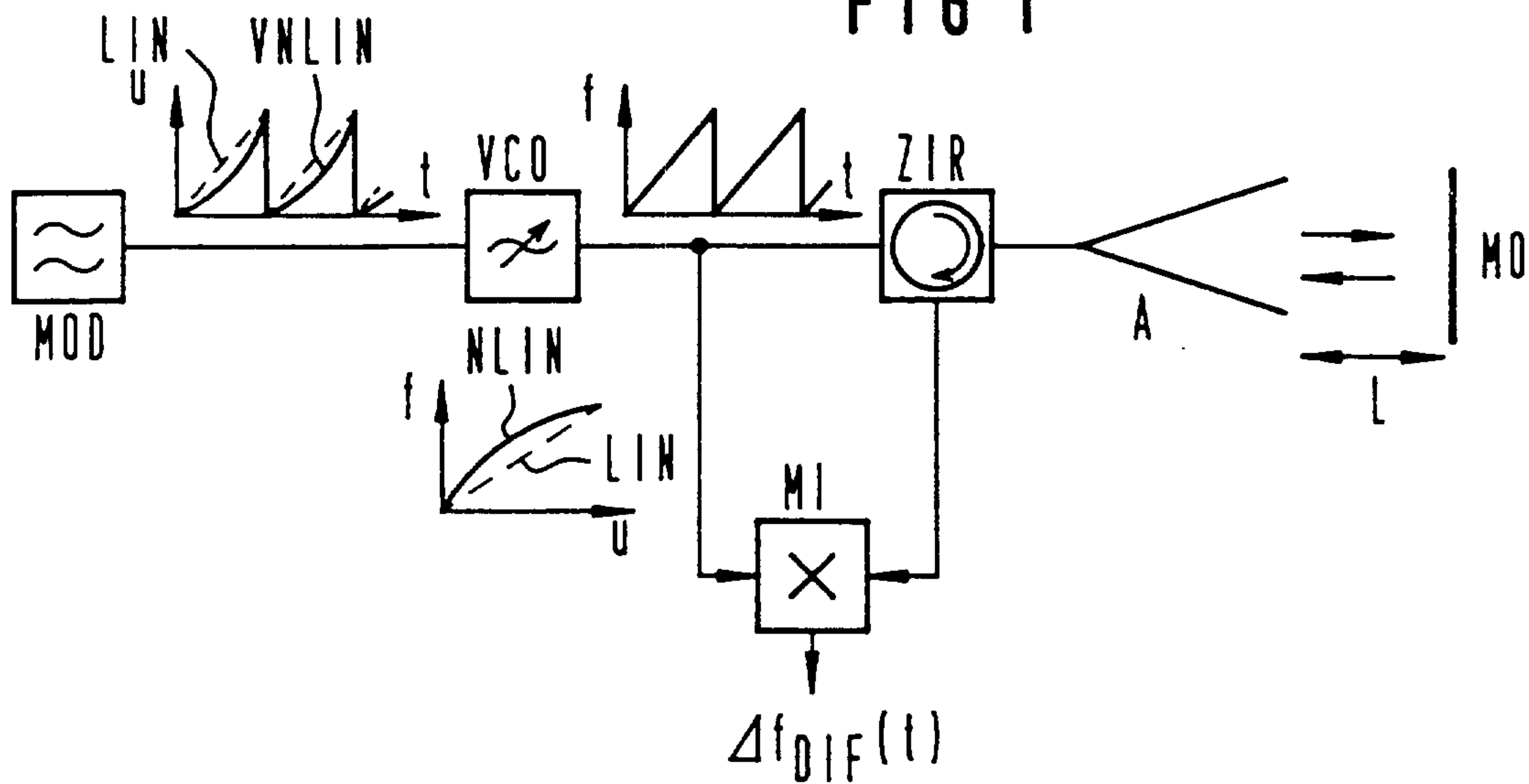

FIG 2

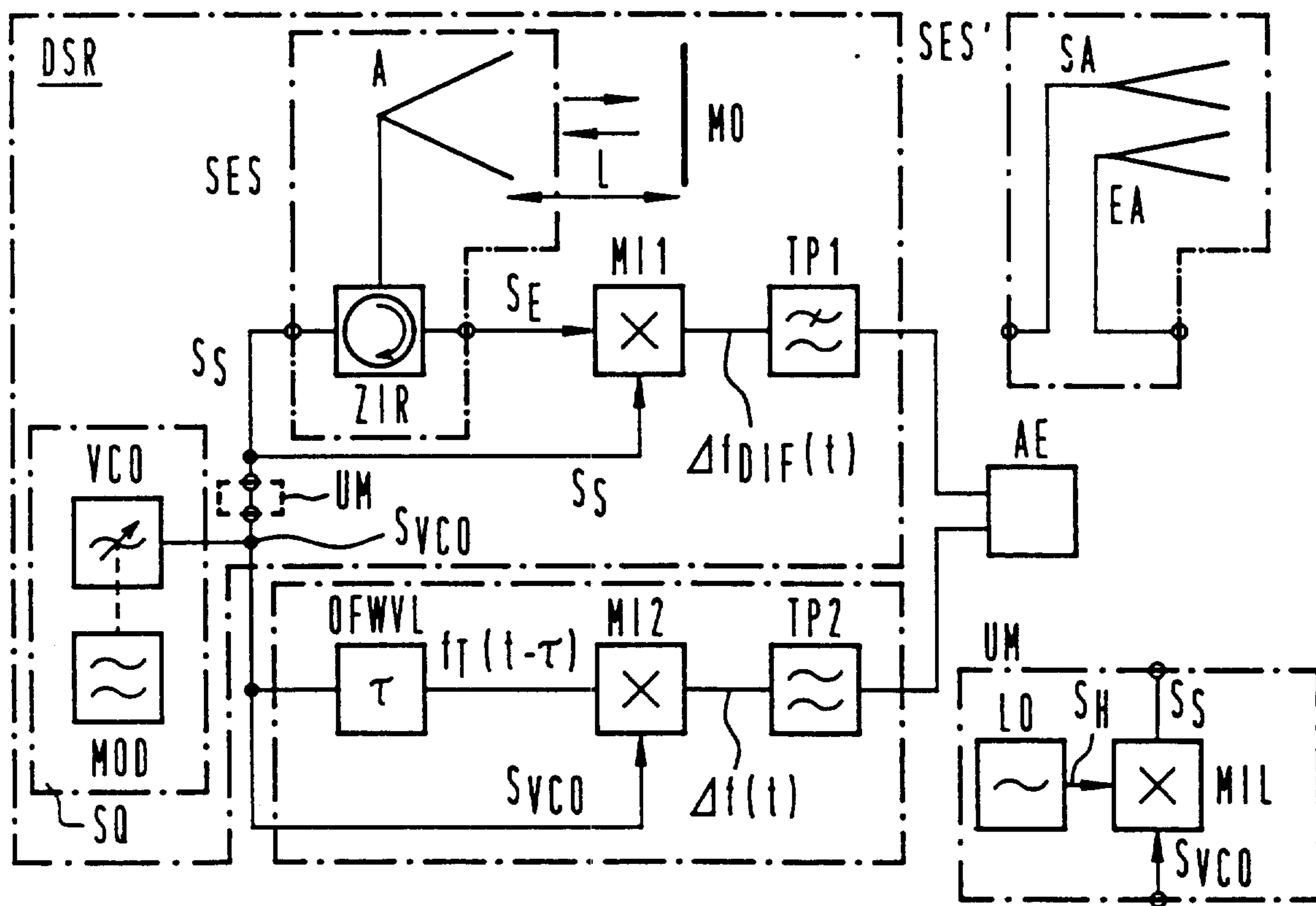
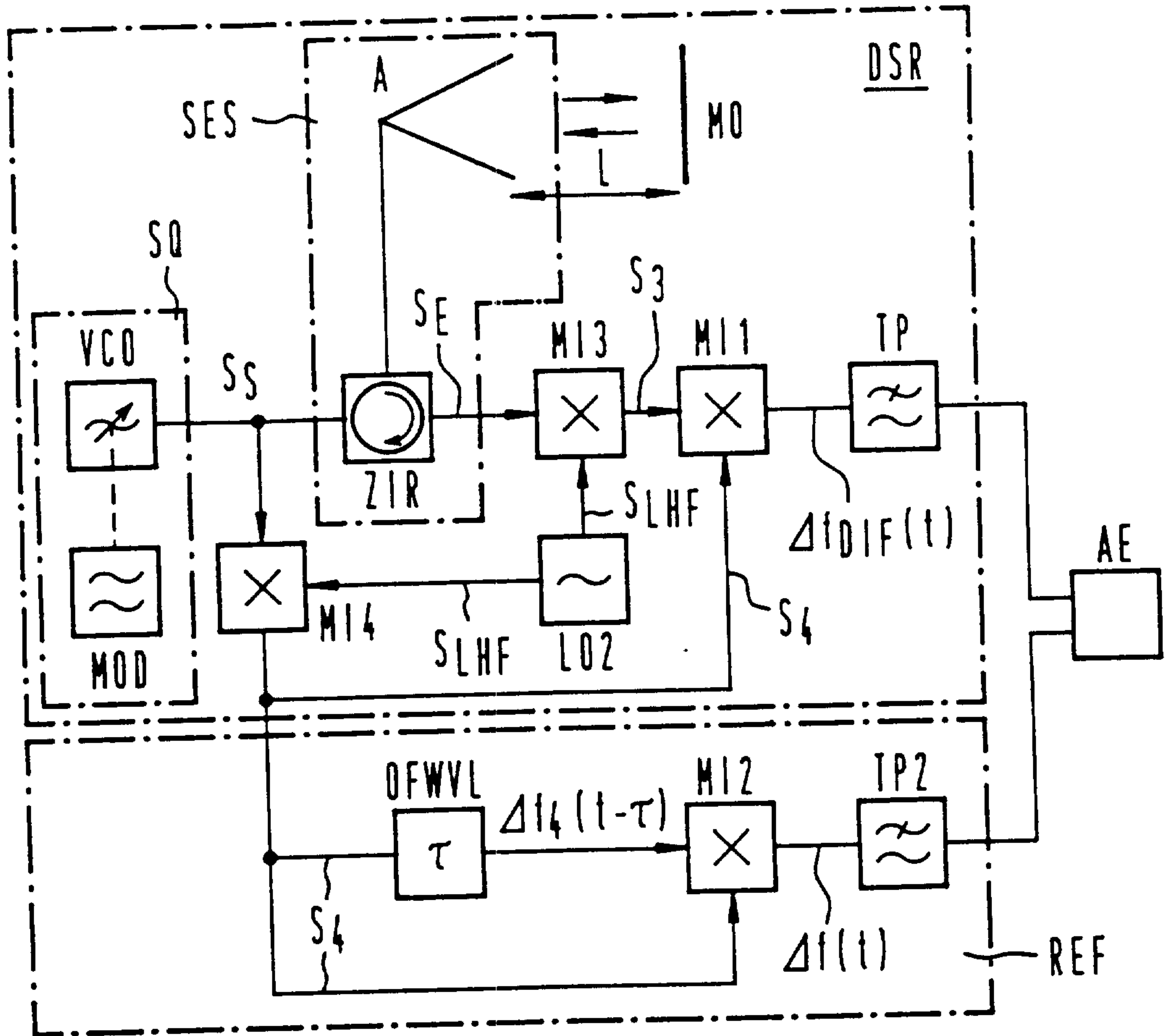

FIG 3



Patent Agents
Fetherstonhaugh & Co.

