

**(12) STANDARD PATENT APPLICATION** (11) Application No. **AU 2006200942 A1**  
**(19) AUSTRALIAN PATENT OFFICE**

(54) Title  
**Filters**

(51) International Patent Classification(s)  
**B01D 25/00** (2006.01) **B01D 29/50** (2006.01)  
**B01D 29/31** (2006.01)

(21) Application No: **2006200942** (22) Date of Filing: **2006.03.03**

(30) Priority Data

(31) Number (32) Date (33) Country  
**248/MUM/2005** **2005.03.04** **IN**

(43) Publication Date: **2006.09.28**

(43) Publication Journal Date: **2006.09.28**

(71) Applicant(s)  
**Fleetguard Filters PVT LTD**

(72) Inventor(s)  
**Sudhakar, Pathak Rahul;Babanrao, Padwal Prasad;Shrikrishna, Kulkarni Vivek;Ganesh, Khandkar Arun;Thomas, Payyapilly Antony**

(74) Agent / Attorney  
**Mills Oakley Patent Attorneys, St James Building 4th Floor 121 William Street, Melbourne, VIC, 3000**

2006200942 03 Mar 2006

## ABSTRACT

5 A filter assembly including a housing, said housing defining an inner surface; a filter  
element located in said housing, said filter element being resiliently spaced apart from  
said inner surface of said housing by a spring element, said filter element defining an  
operative bottom surface; said operative bottom surface of said filter element and said  
inner surface of said housing defining a space; fitment means for fitting said filter  
element within said housing; and at least one compressibly resilient element located in  
10 said space in the operative configuration of said filter assembly.

10

2006200942 03 Mar 2006

**AUSTRALIA**

---

**Patents Act 1990**

---

**COMPLETE SPECIFICATION**

**Invention Title: FILTERS**

2006200942 03 Mar 2006

**Field of the invention:**

This invention relates to filters. In particular, this invention relates to a filter assembly.

**Background of the invention:**

- 5 Filter assemblies are used to filter different types of fluids, such as lubricating oils, fuels, hydraulic oils, coolants, and the like in various engines and other equipment.

10 These filter assemblies preferably consists of a filter element fitted inside a casing and the entire assembly is fitted on a filter head. Dirty fluid enters a filtering chamber housing the filter element through one or more inlets, passes through the filter element, gets filtered, and the filtered fluid exits the assembly through an outlet. Due to the accumulation of dirt in the filter element, fluid permeability of the filter element decreases with time, and eventually it needs to be replaced.

- 15 There are mainly two types of filter assemblies. In one, the filter element is hermetically sealed inside its chamber, and the whole assembly is disposable after use. This type of filter assembly is normally known as "Spin on filter assembly." In the other type, only the filter element is removed from the casing at the end of use and replaced with a new one. This type of filter is normally known as "Cartridge" filter.

20

**Prior Art**

It has been disclosed, but we do not concede it to be part of the common general knowledge, to have a vertical section of typical "spin on" type engine lubricating oil filter assembly as shown in Figure 1 of the accompanying drawings. Dirty oil enters through  
25 the oil inlet (10) into the assembly, passes through the filter element (12) gets filtered and passes through the perforated center tube (14) and exits the assembly through outlet (16). In this example, the cylindrical filter element is made of pleated filter paper bonded to metallic top cap (18) and bottom cap (20). The filter element is fitted inside a metallic shell (22), which is seamed with a nut plate (24) and retainer (26). The retainer (26) is  
30 welded to the nut plate (24). A spring (28) keeps the filter element (12) tightly seated

2006200942 03 Mar 2006

against the nut plate (24) through an inner seal (30) thereby preventing dirty oil mixing with the filtered oil. The outlet (16) is threaded and is used to fit the filter assembly onto the filter head, which is part of the engine oil circuit. A rubber gasket (32) provides a tight seal between the filter assembly and the filter head to prevent oil leakage.

5

Sudden start-and-stop or sudden acceleration and deceleration occur during the operation of the engine. As a result the filter assembly is subjected to several cycles of hydraulic pressure impulses during its usage period. These hydraulic pressure impulses cause fatigue on various parts of the filter assembly leading to failure. As seen in figure 1, parts especially vulnerable to fatigue failure are the seam (34), rubber gasket (30), inner seal (28) and the shell (22).

10

This invention seeks to overcome the limitations of the prior art.

15 An object of this invention is to safeguard the filter assembly from the hydraulic pressure impulses caused due to sudden, start, stop, acceleration, deceleration occurring during engine operation.

Another object of this invention is to provide a filter assembly, which reduces the fatigue in the various part of the engine.

20

Another object of this invention is to provide a shock absorbing means thus reducing the hydraulic pressures acting on the filter components.

25 **Summary of the invention:**

In accordance with this invention there is provided a filter assembly including:

30

- i. a housing, said housing defining an inner surface;
- ii. a filter element located in said housing, said filter element being resiliently spaced apart from said inner surface of said housing by a spring element, said filter element defining an operative bottom surface;

2006200942 03 Mar 2006

- iii. said operative bottom surface of said filter element and said inner surface of said housing defining a space;
- iv. fitment means for fitting said filter element within said housing;
- v. at least one compressibly resilient element located in said space in the operative configuration of said filter assembly;

5

Preferably, said compressible resilient element is in the shape of a doughnut.

Preferably, the compressible resilient element contains any compressible fluid such as air, nitrogen, inert gas and the like.

10

Preferably, said compressible resilient element is of a material selected from a group of materials consisting of sponge, fibre or foam with impermeable skin in a single layer or in multi layers.

15

Preferably, said compressible resilient element may be made from a material which is at least one selected from a group of materials consisting of natural rubber, thermoplastic elastomers, natural leather, synthetic leather, metallic foils, plastic foils, metallic films, plastic films, fabrics, coated fabrics, or a combination thereof.

20

Preferably, said compressible resilient element occupies 0.5% to 80% of the free volume inside the housing

Preferably, said compressible resilient element has an internal pressure ranging from 0.1Kg/cm<sup>2</sup> to 10 Kg/cm<sup>2</sup>.

25

Preferably, said compressible resilient element is provided with any desired geometric or non-geometric shape to fit inside the space defined by the operative bottom surface of the filter element and the inner surface of the housing.

30

2006200942 03 Mar 2006

Preferably, said filter assembly is subjected to hydraulic pressure impulses up to 50 bars (i.e 51 Kg/cm<sup>2</sup>).

**Brief description of the accompanying drawings:**

- 5 The invention will be described in detail with reference to a preferred embodiment. Reference to this embodiment does not limit the scope of the invention.

In the accompanying drawings:

- Figure 1 illustrates a vertical sectional elevation of the filter assembly according to the prior art, as describer herein before;
- 10 Figure 2 illustrates a vertical sectional elevation of the filter assembly according to an embodiment of this invention;
- Figure 3 illustrates a plan view of the compressible resilient element;
- Figure 4 illustrates sectional elevation as seen in the direction of line A-A' as shown in figure 3; and
- 15 Figure 5 illustrates an isometric view of the compressible resilient.

**Detailed description of the invention with reference to the accompanying drawings:**

The invention will now be explained with reference to Figures 2 to 5 of the accompanying drawings.

20

In the accompanying drawings Figure 2 illustrates a vertical sectional view of a filter assembly in accordance with an exemplified embodiment of the invention. The filter assembly helps placing various filter components the filter assembly includes:

- 25 (i) a housing (36) which house various filter components, operative top end of the housing which is open and operative bottom end is closed, said housing defining an inner surface.
- (ii) a spring element (38) is placed within the housing on the inner surface of the housing (36). The spring element (38) accommodate a filter element (40) in a manner such that filter element (40) is
- 30 placed on the spring element.

2006200942 03 Mar 2006

- (iii) a filter element (40) for filtering the oil entering said filter assembly adapted to be located within the housing (36). The filter element (40) is resiliently spaced apart from the inner surface of the housing (36) by a spring element (38). The filter element (40) has an operative bottom surface. The operative bottom surface of the filter element (40) and the inner surface of housing (36) define a space.

The filter element (40) includes:

- 10 (a) an operatively bottom end cap (42) which is fitted over the spring element (38) in a manner such that a space (43) is defined between bottom end cap (42) of the filter element (38) and the operative bottom end of the housing (36).
- 15 (b) a perforated tube (44) is mounted centrally over the bottom end cap (42).
- (c) plurality of filter paper elements (46) are mounted on the bottom end cap (42) in a manner such that at least one filter paper element (46) is placed on either side of the perforated tube (44).
- 20 (d) an operatively top end cap (48) is fitted to the operative top end of the filter element (40) in a manner such that it covers the operative top end of the filter element.
- (e) at least one compressible resilient element (50) which is located in the space (43) defined between said operative bottom end of said filter element (40) and inner surface of the housing (36).
- 25 (f) fitment means (52) for fitting the various components of the filter assembly;
- (g) a plurality of sealing means for sealing the operative top end of said housing, said sealing means may include rubber
- 30

gaskets (54), seam joints (56), retainers (58), nut plates (60), inner sealing element (62) and the like.

Figure 3, figure 4 and figure 5 respectively illustrates a plan view, a sectional elevation as seen in the direction of line A-A' as shown in figure 3 and an isometric view of the compressible resilient element. The compressible resilient element (50) is in the shape of a doughnut. The ring member (64) of the doughnut shaped compressible resilient means may be filled with any compressible fluid such as air, nitrogen, inert gas and the like. The compressible resilient element (50) may be made from a material selected from a group of materials, which include sponge, fibre or foam with impermeable skin in a single layer or in multi layers. The compressible resilient element (50) may be made from a material which may be one selected from a group of material such as natural rubber, thermoplastic elastomers, natural leather, synthetic leather, metallic foils, plastic foils, metallic films, plastic films, fabrics, coated fabrics, or a combination thereof. The compressible resilient element (50) occupies 0.5% to 80% of the free volume inside the housing and having an internal pressure ranging from 0.1Kg./cm<sup>2</sup> to 10 Kg./cm<sup>2</sup>. Although the compressible resilient element (50) as shown in the preferred embodiment is in the shape of a doughnut, it is possible that the element (50) may be of any desired geometric or non geometric shape. Inclusion the compressible resilient element (50) inside the filter assembly reduces the magnitude of the hydraulic pressure impulse by 10% to 90% thereby reducing the stress on the pressure-sensitive parts of the filter assembly, such as the housing inner seal, gasket seam joints, welded joints, crimped joints etc. which in turn increases the impulse fatigue resistance of the filter assembly up to 15 times.

#### 25 Construction of the Doughnut-shaped Elements:

The element (50) is imagined to be consisting of two symmetrical halves joined to each other, the plane of symmetry being the plane passing through the centre of the thickness of the outer and inner rims and parallel to them. A compression-moulding die is made to mould the symmetrical half. Such halves are compression moulded from nitrile-rubber compound. Then a 0.2 mm thick annular ring having the dimensions to match the outer

2006200942 03 Mar 2006

rim and another one to match the dimensions of the inner ring are cut from a sheet of uncured nitrile rubber compound and the same are placed over the respective rims of one half. Another symmetrical half is joined face-to-face to it such that the uncured rubber rings are sandwiched between the inner and outer rims of the two halves. This assembly  
5 is then cured by applying pressure at a particular temperature in a mould whereupon the uncured nitrile rubber compound cures and bonds the two halves. The finished doughnut-shaped element is obtained by demoulding.

The invention is further illustrated in the form of examples. However, these examples  
10 should not be construed as limiting the scope of the invention.

#### Example 1

In an embodiment of the invention spin-on type fuel filters, similar to that shown in the accompanying drawings, were manufactured incorporating one hollow, doughnut-shaped,  
15 compressible and resilient element, where the spin-on filter had overall height of 137.8 mm, inside diameter of 92.4 mm, housing thickness of 0.71 mm, nut plate thickness of 3.05 mm and inner free volume of 760 ml (including the volume occupied by the doughnut-shaped, compressible and resilient element). The doughnut-shaped, compressible resilient means were filled with air at 1 atm pressure (i.e. 1.03325 Kg/cm<sup>2</sup>  
20 which is equivalent to 14.508 psi). The filters made as per prior art and those made as per the present invention were mounted on a dynamic impulse test stand and subjected to the same hydraulic pulse at various levels and a comparative evaluation has been carried out.

The results have been tabulated in table 1.  
25

2006200942 03 Mar 2006

Table 1.

Sample no.	Hydraulic pulse flow in terms of adjustable valve opening (%)	Pressure experienced by filter as per prior art (psi)	Pressure experienced by filter as per present invention (psi)
1	20	100	97
2	30	120	114
3	40	140	132
4	50	160	508
5	60	175	160

**Example 2**

In an embodiment of the invention spin-on type fuel filters, similar to that shown in the attached drawing, were manufactured incorporating two hollow, doughnut-shaped, compressible resilient means, dimensions of the filter assembly are the same as mentioned in example 1. The doughnut-shaped compressible resilient means were filled with air at 1 atm pressure (i.e 1.03325 kg/cm<sup>2</sup> which is equivalent to 14,508 psi). The filters made as per prior art and those made as per the present invention were mounted on a dynamic impulse test stand and subjected to the same hydraulic pulse at various levels and a comparative evaluation has been carried out.

The results have been tabulated in table 2.

2006200942 03 Mar 2006

Table 2.

Sample no.	Hydraulic pulse flow in terms of adjustable valve opening (%)	Pressure experienced by filter as per prior art (psi)	Pressure experienced by filter as per present invention (psi)
1	20	100	92
2	30	120	108
3	40	140	121
4	50	160	137
5	60	175	148

**Example 3**

- 5 In an embodiment of the invention spin-on type fuel filters, similar to that shown in the attached drawing, were manufactured incorporating two hollow, doughnut-shaped, compressible resilient means, dimensions of the filter assembly are the same as mentioned in example 1. The doughnut-shaped compressible resilient means were filled with air at 1 atm pressure (i.e. 1.03325 kg/cm<sup>2</sup> which is equivalent to 14.508 psi). The
- 10 filters made as per prior art and those made as per the present invention were mounted on a dynamic impulse test stand and subjected to the same hydraulic pulse at various levels and a comparative evaluation has been carried out.

The results have been tabulated in table 3.

15

2006200942 03 Mar 2006

Table 3

Sample no.	Hydraulic pulse flow in terms of adjustable valve opening (%)	Pressure experienced by filter as per prior art (psi)	Pressure experienced by filter as per present invention (psi)
1	20	100	87
2	30	120	102
3	40	140	118
4	50	160	130
5	60	175	140

While considerable emphasis has been placed herein on the various components of the preferred embodiment and the interrelationships between the component parts of the preferred embodiment, it will be appreciated that many alterations can be made and that many modifications can be made in the preferred embodiment without departing from the principles of the invention. These and other changes in the preferred embodiment as well as other embodiments of the invention will be apparent to those skilled in the art from the disclosure herein, whereby it is to be distinctly understood that the foregoing descriptive matter is to be interpreted merely as illustrative of the invention and not as a limitation.

15

20

25

2006200942 03 Mar 2006

The claims defining the invention are as follows:

1. A filter assembly including:
- i. a housing, said housing defining an inner surface;
  - 5 ii. a filter element located in said housing, said filter element being resiliently spaced apart from said inner surface of said housing by a spring element, said filter element defining an operative bottom surface;
  - 10 iii. said operative bottom surface of said filter element and said inner surface of said housing defining a space;
  - iv. fitment means for fitting said filter element within said housing; and
  - v. at least one compressibly resilient element located in said space in the operative configuration of said filter assembly.
- 15 2. A filter assembly as claimed in claim 1, wherein said compressible resilient element is in the shape of a doughnut.
3. A filter assembly as claimed in claim 1 or 2, wherein the compressible resilient element contains a compressible fluid such as air, nitrogen, inert gas and the like.
- 20 4. A filter assembly as claimed in claim 1, 2, or 3 wherein the said compressible resilient element is made of a material selected from a group of materials consisting of sponge, fibre and foam with impermeable skin in a single layer or in multi layers.
- 25 5. A filter assembly as claimed in claim 1, 2, or 3, wherein the said compressible resilient element is made of a material which is at least one selected from a group of materials consisting of natural rubber, thermoplastic elastomers, natural leather, synthetic leather, metallic foils, plastic foils, metallic films, plastic films, fabrics and coated fabrics.
- 30

2006200942 03 Mar 2006

6. A filter assembly as claimed in any one of the preceding claims, wherein the said compressible resilient element occupies 0.5% to 80% of the free volume inside the housing.

5 7. A filter assembly as claimed in any one of the preceding claims, wherein said compressible element has an internal pressure substantially in the range of 0.1Kg./cm<sup>2</sup> to 10 Kg./cm<sup>2</sup>.

8. A filter assembly as claimed in any one of the preceding claims, wherein said  
10 compressible resilient element has a geometric or non-geometric shape to fit inside the housing of said filter assembly.

9. A filter assembly as claimed in any one of the preceding claims, wherein said filter assembly is subjected to hydraulic pressure impulses up to 50 bars/51Kg./cm<sup>2</sup>.

15

10. A filter assembly as claimed in claim 1, as described herein with reference to the accompanying drawings.

11. A compressibly resilient element in the shape of a doughnut for locating inside  
20 said filter assembly as claimed in any one of the preceding claims.

12. A filter assembly substantially as herein described with reference to the accompanying drawings.

25

2006200942 03 Mar 2006

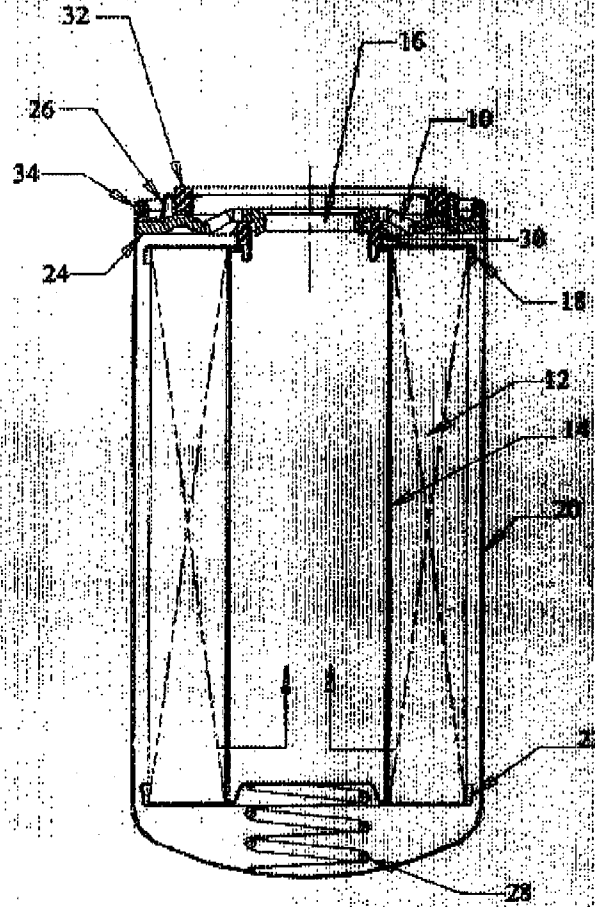

FIGURE 1

2006200942 03 Mar 2006

2/3

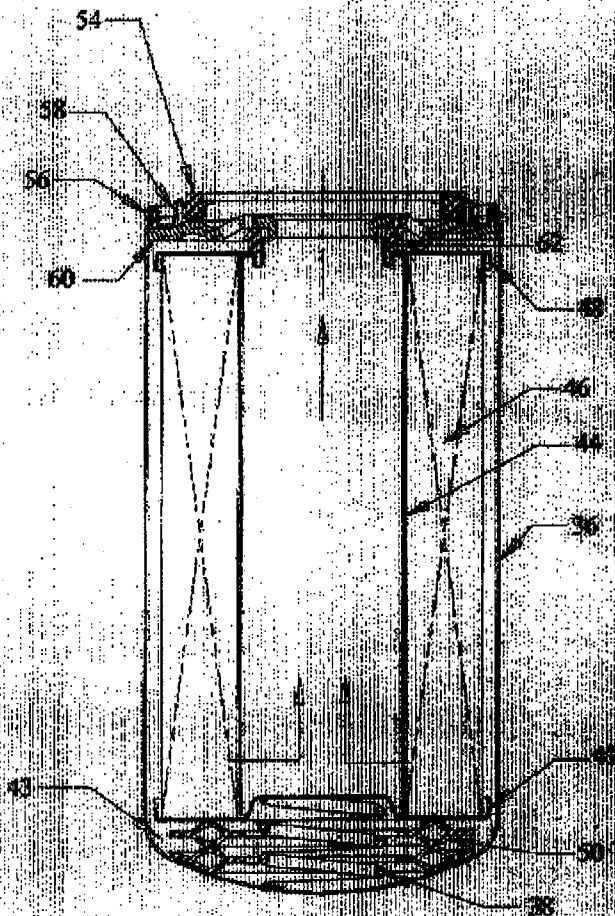

FIGURE 2

2006200942 03 Mar 2006

