



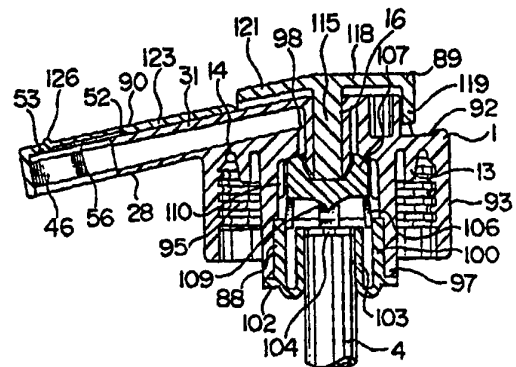
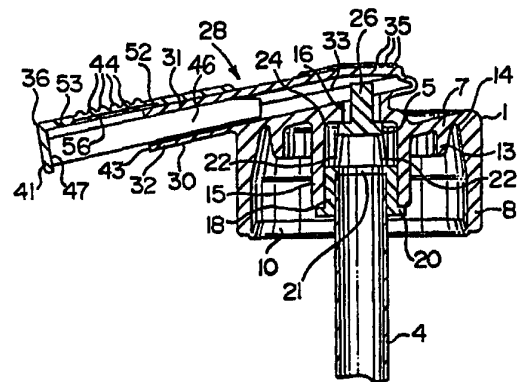
INTERNATIONAL APPLICATION PUBLISHED UNDER THE PATENT COOPERATION TREATY (PCT)

<p>(51) International Patent Classification <sup>6</sup> : <b>B67D 1/04, B65D 83/16</b></p>	<p><b>A1</b></p>	<p>(11) International Publication Number: <b>WO 95/31398</b> (43) International Publication Date: 23 November 1995 (23.11.95)</p>
<p>(21) International Application Number: PCT/IB95/00321 (22) International Filing Date: 4 May 1995 (04.05.95) (30) Priority Data: 2,123,446 12 May 1994 (12.05.94) CA U 95 00067 21 March 1995 (21.03.95) HU  (71) Applicant (for all designated States except US): ADVANCED JET TECHNOLOGIES INCORPORATED [CA/CA]; Suite 205, 4360 Côte de Liesse, Montreal, Quebec H4N 2P9 (CA). (72) Inventor; and (75) Inventor/Applicant (for US only): LINDMAYER, Stephen, I. [CA/CA]; 4390 Gilles Street, Pierrefonds, Quebec H9H 2N4 (CA).</p>	<p>(81) Designated States: AM, AT, AU, BB, BG, BR, BY, CA, CH, CN, CZ, DE, DK, EE, ES, FI, GB, GE, HU, JP, KE, KG, KP, KR, KZ, LK, LR, LT, LU, LV, MD, MG, MN, MW, MX, NO, NZ, PL, PT, RO, RU, SD, SE, SI, SK, TJ, TT, UA, US, UZ, VN, European patent (AT, BE, CH, DE, DK, ES, FR, GB, GR, IE, IT, LU, MC, NL, PT, SE), OAPI patent (BF, BJ, CF, CG, CI, CM, GA, GN, ML, MR, NE, SN, TD, TG), ARIPO patent (KE, MW, SD, SZ, UG).  <b>Published</b> <i>With international search report.</i> <i>With amended claims.</i></p>	

(54) Title: CONTAINER COVER AND DISPENSING DEVICE

(57) Abstract

A cover and dispensing device for use on a container (3) of liquid under pressure, comprises cap (1) for mounting on the open top end (2) of the container (3), a tubular nozzle (28) having an open outer end (43) for discharging the liquid, a channel (16, 98) between the nozzle (28) and the container (3) inside with an open bottom end for receiving fluid from the container (3), a valve seat (24) and a valve body (5, 88, 130) for closing and opening the way of liquid through the channel. The said nozzle (28) is on the upper side of the cap (1) integral with the circular top wall (7) of the cap (1), and the cap (1) has a cylindrical side wall (8) making the sealing engagement on the open top end (2) of the container (3). The said circular top wall (7) has a central opening (16) with a plunger (26) of the valve body (5, 88, 130) in it. The valve seat (24) is on the inner surface of the top wall (7) around the inner end of the central opening (16) and the valve body sealing against the valve seat (24) is arranged below the inner surface of the top wall (7). The nozzle (28) leads into the central opening (16) or into an annular groove (98) surrounding the central opening (16). They can adjust the plunger (26) with pressing the nozzle's (28) resilient inner end covering the plunger (26), or pressing directly the plunger (26) in the case of preferred embodiment with said annular groove (98).



**FOR THE PURPOSES OF INFORMATION ONLY**

Codes used to identify States party to the PCT on the front pages of pamphlets publishing international applications under the PCT.

AT	Austria	GB	United Kingdom	MR	Mauritania
AU	Australia	GE	Georgia	MW	Malawi
BB	Barbados	GN	Guinea	NE	Niger
BE	Belgium	GR	Greece	NL	Netherlands
BF	Burkina Faso	HU	Hungary	NO	Norway
BG	Bulgaria	IE	Ireland	NZ	New Zealand
BJ	Benin	IT	Italy	PL	Poland
BR	Brazil	JP	Japan	PT	Portugal
BY	Belarus	KE	Kenya	RO	Romania
CA	Canada	KG	Kyrgystan	RU	Russian Federation
CF	Central African Republic	KP	Democratic People's Republic of Korea	SD	Sudan
CG	Congo	KR	Republic of Korea	SE	Sweden
CH	Switzerland	KZ	Kazakhstan	SI	Slovenia
CI	Côte d'Ivoire	LI	Liechtenstein	SK	Slovakia
CM	Cameroon	LK	Sri Lanka	SN	Senegal
CN	China	LU	Luxembourg	TD	Chad
CS	Czechoslovakia	LV	Latvia	TG	Togo
CZ	Czech Republic	MC	Monaco	TJ	Tajikistan
DE	Germany	MD	Republic of Moldova	TT	Trinidad and Tobago
DK	Denmark	MG	Madagascar	UA	Ukraine
ES	Spain	ML	Mali	US	United States of America
FI	Finland	MN	Mongolia	UZ	Uzbekistan
FR	France			VN	Viet Nam
GA	Gabon				

- 1 -

Container Cover and Dispensing Device

This invention relates to a container cover and dispensing device.

More specifically, the invention relates to a bottle cover and dispensing device for use on a container for liquid  
5 under pressure such as a cola or other carbonated soft drink.

In general, carbonated beverages are available in small glass or plastic bottles or in metal cans for immediate consumption, or in a variety of large glass or plastic bottles.  
10 Larger bottles are intended to store some of the beverage after the bottle has been opened and some of the contents removed. Often the beverage remains in a previously opened bottle for days at a time, and the carbonation often dissipates leaving the drink "flat". Moreover, the mere act of pouring a soft drink from a bottle /particularly  
15 by children/ can be awkward and messy.

Accordingly, a need exists for a cover and dispensing device which facilitates dispensing of carbonated or other beverages under pressure, and which reduces the loss of  
20 pressure on already opened containers, i.e. containers from which some of the contents have been dispensed.

An object of the present invention is to meet the above defined need by providing a relatively simple and inexpensive container cover and dispensing device, which makes  
25 it easy to dispense a liquid under pressure, without moving the bottle containing the liquid.

A second object of the invention is to provide a device

which, once placed on the container remains in position and reduces the likelihood of loss of pressure until all of the liquid has been dispensed.

Another object of the invention is to provide a device  
5 which makes it difficult to dispense the liquid in a container unintentionally which is important in households with young children.

Accordingly, the invention relates to a cover and dispensing device for use on a container of liquid under pressure  
10 comprising cap means for mounting on the open top end of the container, said cap means including cylindrical side wall and circular top wall for mounting in sealing engagement on the open top end of the container; preferably sleeve means extending downwardly from said top wall, said  
15 sleeve means having an open bottom end for receiving fluid from the container, an open top end for discharging fluid from the container and valve seat in said open top end; and valve means preferably in said sleeve means; said valve means including tubular body fixed in said sleeve means;  
20 head on said body normally sealing against said valve seat; plunger extending upwardly from said head through top wall; and resilient cage defining a section of the valve body beneath said head, whereby, when said plunger is pressed downwardly, the cage is deformed to move said head away  
25 from valve seat permitting the discharge of fluid through cage and from the container, or the said valve means including a resilient plate shape normally sealing against the valve seat and when the plunger is pressed downwardly,

said plate shape is deformed moving away from the valve seat.

The invention will be described in greater detail with reference to the accompanying drawings, which illustrate preferred embodiments of the invention, and wherein:

Figure 1 is a side view of a container cover and dispensing device in accordance with the present invention on the top end of a container;

Figure 2 is a side view of the device of Fig. 1 on a larger scale;

Figure 3 is a top view of the device of Figs. 1 and 2;

Figure 4 is a cross section taken generally along line IV-IV of Fig. 3 showing the device in the closed and open positions;

Figure 5 is a cross section similar to Fig. 4 showing the device in the open position;

Figure 6 is a perspective view of a valve body used in the device of Figs. 1 to 5;

Figure 7 is a top view of the device of Figs. 1 to 5 with the cover removed;

Figure 8 is a top view of a cover used on the device of Figs. 1 to 5;

Figure 9 is a side view of the cover of Fig. 8;

Figure 10 is an end view of the cover of Figs. 8 and 9 as seen from the right of Fig. 9;

Figure 11 is a bottom view of the cover of Figs. 8 to 10;

Figure 12 is a cross section taken generally along

line XII-XII of Fig. 8;

Figure 13 is a cross section taken generally along  
line XIII-XIII of Fig. 11;

Figure 14 is a side view of a second embodiment of a  
5 cover and dispensing device in accordance with the present  
invention;

Figure 15 is a top view of the device of Fig. 14;

Figure 16 is a cross sectional view of the device of  
Figs. 14 and 15, and the top end of a bottle;

10 Figure 17 is a side view of a third embodiment of  
the cover and dispensing device of the present invention;

Figure 18 is an end view of the device of Fig. 17 as  
seen from the left of such figure; and

15 Figure 19 is a schematic side view of a fourth  
embodiment of the device of the present invention on a bottle  
mounted in a stand;

Figure 20 is an exploded cross-sectional view of a  
fifth embodiment of the container cover and dispensing device;

20 Figure 21 is a cross-sectional view of the device of  
Fig. 20 in assembled condition;

Figure 22 is a top view of a valve body used in the  
device of Figs. 20 and 21;

Figure 23 is a side view of the valve body of Fig.  
22;

25 Figure 24 is a bottom view of the valve body of  
Figs. 22 and 23;

Figure 25 is a top view of a cap used in the device of Figs. 20 and 21;

Figure 26 is a bottom view of the cap of Fig. 25;

Figure 27 is a side view of the cap of Figs. 25 and 26, the bottom end of the valve body and the top end of a tube used in the device of Figs. 20 and 21; and

Figure 28 is a front view of the cap, valve body and tube of Fig. 27.

Figure 29 is a cross-sectional view of a sixth embodiment of the cover and dispensing device;

Figure 30 is the device of Fig.29. supplied with a press-arm means;

Figure 31 is a cross-sectional view of the cap used in the device of Fig.29.

Figure 32 is a top view of the cap of Fig.31;

Figure 33 is a cross-sectional view of the valve body used in the device of Fig.29;

Figure 34 is a top view of the valve body of Fig.33;

Figure 35 is a cross-sectional view of the plunger and the top plate used in the device of Fig.29;

Figure 36 is a bottom view of the top plate of Fig.35;

Figure 37 is a cross-sectional view of the embodiment of Fig.29. with latch means instead of thread in inner side of the side wall.

Wherever possible the same reference numerals have been used to identify the same or similar elements in the various figures of the drawings. In many cases, elements have been omitted from figures of the drawings to simplify illustration of the invention. In the following detailed description, the only container described for use with the device of the present invention is a plastic soft drink bottle. However, it will be appreciated that the device can be used on other containers for pressurized liquid.

With reference to Figs. 1 to 5, the basic elements of a cover device in accordance with the present invention include a cap 1 for mounting in sealing engagement on the open top end of a bottle 3, a tube 4 extending between the bottom of the bottle 3 and the cap 1, and a valve body 5 (Figs. 4 to 6) mounted in the cap 1.

The cap 1 is defined by a circular, slightly concave top wall 7, and a cylindrical side wall 8 integral with the top wall 7 and extending downwardly therefrom. The cap 1 is retained on the bottle 3 by a thin, upwardly and inwardly inclined, annular skirt or flange 10 on the bottom end of the side wall 8. The flange 10 engages a shoulder 11 on the top end of the bottle 2. A seal between the cap 1 and the bottle 2 is achieved by means of an annular wall 13 parallel to and substantially shorter than the side wall 8. As best shown in Fig. 4, when the cap 1 is placed on a bottle 2 the top end of the bottle extends into an inverted V-shaped recess 14 between



- 7 -

the wall 8 and the sleeve 13. Thus, a seal is achieved between the top end of the bottle 2 and the cap 1.

A sleeve 15 (Fig. 4 and 5) extends downwardly around a central opening 16 in the top wall 7 of the cap 1. The sleeve 15 defines a valve casing for the valve body 5. As best shown in Fig. 6, the valve body 5 includes a tubular, cylindrical bottom section 18 which is retained in the sleeve 15 by friction. An annular flange 20 on the bottom end of the section 18 limits upward movement of the valve body 5 in the sleeve 15. The top end of the tube 4 extends into the bottom section 18 of the valve body 5 and abuts an annular, inwardly extending flange or shoulder 21 at the upper end of such bottom section. Three narrow, resilient arms 22 extend upwardly and inwardly from the upper end of the bottom section 18 and support a disc 23 of smaller diameter than the bottom section 18. The disc 23 normally rests against a shoulder 24 around the opening 16 (Figs. 4 and 5) in the top wall 7 of the cap which defines a valve seat. The valve body is formed of a material such as a rubber, which is sufficiently resilient and flexible that the arms 22 are relatively easy to bend and the disc 23 seals tightly against the shoulder 24. The disc 23 is moved away from the valve seat by a plunger 26 extending upwardly from the center of the disc 23 through the opening 16. The plunger 26 is smaller in diameter than the opening 16 so that fluid can escape through the opening when the valve is open.

Fluid escaping through the opening 16 is discharged from the device via a downwardly inclined dispensing nozzle

generally indicated at 28 integral with the cap 1. The nozzle 28 (Figs. 7, 15 and 18) includes a elongated, generally rectangular cross section body 30 defined by a top wall 31, a bottom wall 32 and side walls 33. The side walls 33 are generally V-shaped in cross section to facilitate flexing of the nozzle in the manner of an accordion. Small, generally U-shaped ridges 35 extend upwardly from the top wall 31 near the semicircular inner end thereof. The ridges 35 define finger grips for the user, i.e. prevent sliding of a fingertip from the top wall 31 when the device is being used. The valve is opened during a dispensing operation by pressing down on the top wall 31 against the plunger 26 to flex the arms 22 and thus move the disc 23 away from the valve seat (shoulder 24). The liquid in the bottle 3 is propelled therefrom by its own pressure, i.e. by the carbonation pressure.

In the first embodiment of the invention, the nozzle 28 is closed by a cover 36 when the device is not in use. The cover 36 not only closes the nozzle 28, but prevents an unauthorized or accidental dispensing operation, for example by a child. As best shown in Figs. 8 to 13, the cover 36 includes an elongated, rectangular body 38 with an open bottom end which is defined by a rectangular top wall 39, side walls 40 and an outer end wall 41. The end wall 41 is wider than the side walls 40 for closing the outer, discharge end 43 of the nozzle 28. A plurality of small ribs 44 extend transversely of the top and side walls of the cover 36 facilitating fingertip gripping and moving of the cover. The cover 36 is slidably mounted on the nozzle body 30 by means of

a pair of slides defined by elongated arms 46 connected at one end to the interior surface 47 of the cover end wall 41. The arms 46 extend from the end wall 41 to a location beyond the other, open end 48 of the cover, so that, when the cover 36 is in the closed position (shown in solid lines in Fig. 4), the inner, free ends of the arms 46 bear against the upper, inner end of the top wall 31 of the nozzle 28. Thus, the arms 46 prevent downward movement of the top wall 31 and consequently of the plunger 26 and opening of the valve.

10           The cover 36 is maintained on the nozzle 28 by a stop defined by a small transversely extending projection 52 (Figs. 4, 5, 7, 15 to 18) on the outer top end of the nozzle 28. In the closed position (Fig. 4) of the cover 36, the projection 52 rests in a small, straight groove 53 extending  
15 transversely of the inner surface 54 (Figs. 5 and 11 to 13) of the top wall 39 of the cover near the outer end wall 41. The projection 52 and the recess 53 act as a lock for releasably latching the cover 36 in the closed position. By applying downward and outward pressure to ribs 44, the cover 36 is  
20 caused to move outwardly. When the cover 36 moves outwardly, the projection 52 enters an elongated rectangular recess 56 in the inner surface 54 of the cover 36 for free sliding movement of the cover. The upper, inner end 57 of the recess 56 acts as a stop for limiting movement of the cover 36 to the open  
25 position (see Fig. 4 in phantom outline and Fig. 5 in solid lines). Square recesses 58 (Figs. 10 and 11) are provided at the sides of the top end of the surface 54 so that the cover 36 can pass over the ends of the ridges 35 when moving to the

closed position.

A second embodiment of the invention (Figs. 14 to 16) includes the same elements as described above in connection with Figs. 1 to 13, and a pair of arcuate walls 60 extending upwardly from opposite sides of the top wall 7 of the cap 1. The walls 60 define barriers which limit ready access to the nozzle 28 to locations immediately in front of and immediately behind the nozzle. This arrangement further reduces the likelihood of accidental or unauthorized opening of the valve, and as shown in Figs. 14 to 16, can be used without the cover 36. As shown in Fig. 14, the dispensing device can be used with a short tube or straw 61 on an accordion-type bottle 62, which includes pleats 63 in the side wall 64 thereof, whereby the bottle collapses as the contents are discharged therefrom.

With reference to Figs. 17 and 18, a third embodiment of the invention, which is similar to the first two embodiments, includes a thin, annular skirt 66 extending downwardly from the bottom end of the sidewall 8 of the cap, for sealing engagement with a neck of a bottle (not shown). The skirt 66, which includes a plurality of V-shaped grooves 67 therein, replaces the flange 10 used in the first two embodiments of the invention.

A cover and dispensing device in accordance with the present invention can also be used for downward dispensing of the contents of a bottle 3 in which case the tube 4 can be omitted. As shown in Fig. 19, the bottle 3 can be mounted in an inverted position on an L-shaped stand 70 of the type

including a bracket 71 for holding the bottle 3. The nozzle 73 of the cover and dispensing device is inclined downwardly (rather than upwardly) when the bottle and the device are in the inverted position. When a drinking glass 74 or other  
5 container for receiving some of the contents of the bottle 3 is pressed against an arcuate arm 76 of a resilient lever 77, the other arm 79 of the lever 77 rotates downwardly against one end 80 of a second lever 82. The lever 82 is pivotally mounted on a horizontal arm 83 of the stand 70 for rotation  
10 around a horizontal axis 84, whereby an outer free end 85 thereof presses upwardly against the top wall of the cap 1 to open the valve, initiating a dispensing operation. As long as pressure is applied to the bottom end of the lever 77, liquid will be dispensed from the bottle 3 (of course, until the  
15 bottle is empty). When the lever 77 is released by removal of the glass 74, the levers 77 and 82 return to the rest position, and the valve again closes, terminating the dispensing operation.

With reference to Figs. 20 to 28, a fifth embodiment  
20 of the cover device of the present invention includes a cap 1 for mounting on the top end of a bottle, a tube 4 (Figs. 20 and 21), a valve body 88, a plunger assembly 89 separate from the valve body 88, and a cover 90 slidable on the nozzle 28 of the cap 1 for closing the nozzle.

25 Like the cap of Figs. 1 to 5, the cap 1 is defined by a circular top wall 92, and a cylindrical side wall 93 integral with the top wall 92 and extending downwardly therefrom. Threads 95 are provided on the interior of the

side wall 93 for mounting the cover device on a plastic soft drink bottle. A seal between the cap 1 and the bottle is achieved by an annular wall 13 parallel to and substantially shorter than the side wall 93. As with the above described first embodiment of the invention, when the cap 1 is placed on a bottle, the top end of the bottle extends into an inverted V-shaped recess 14 between the wall 93 and the sleeve 13.

A sleeve 97 extends downwardly around a central opening 98 in the top wall 92 of the cap 1. The sleeve 97 defines a valve casing for a valve body 88. As best shown in Figs. 20 and 22 to 25, the valve body 88 includes a tubular, cylindrical lower section 100, which is retained in the sleeve 97 by friction. A shoulder 101 in the sleeve 97 and an annular flange 102 extending outwardly from the middle of the lower section 100 limit movement of the valve body into the sleeve 97. The end 103 of the lower section 100 beneath the flange 102 has a thinner wall than the top end above the flange 102, so that the bottom end of the valve body can be rolled upwardly and inwardly for receiving the top end of the tube 4. Lugs 104 extend outwardly from the bottom end of the lower section, so that when the bottom end 103 is rolled up into the center of the lower section 100, the lugs 104 define stops for limiting movement of the tube into the valve body.

Four narrow, resilient arms 106 extend upwardly and inwardly from the top end of the lower section 100 of the valve body 88 and support a generally button-shaped head 107. A small pointed projection 109 is provided on the bottom center of the head 107 for directing liquid outwardly from the

top of the straw 4 through the gap between the arms 106. The head 107 is centered and guided by four longitudinally extending ribs 110 in the top end of the sleeve 97. A tube 112 extends downwardly from the center of a raised portion 113 of the top wall 92 of the cap through the opening 98 for  
5 slidably receiving the plunger 115 of the plunger assembly 89. The bottom ends of the tube 112 and of the plunger 115 are seated in a central recess 116 in the head 107 of the valve body 88. As shown in Fig. 21, the plunger 115 is longer than  
10 the sleeve 112 so that the top end of the plunger extends upwardly beyond the top end of the raised central portion 113 of the top wall 92.

The plunger assembly 89 includes the plunger 115, a generally circular top plate 118 and a skirt 119 extending  
15 downwardly from all but one side of the top plate 118. One side 121 of the top plate 118 is inclined downwardly and extends outwardly over the top wall 31 of the nozzle 28. The inclined side 121 of the top wall 118 is parallel to and spaced apart from the top wall 31 of the nozzle 28, so that  
20 the plunger 115 can be moved downwardly to open the valve when pressure is exerted on the top wall 118. When the device is in use, the cover 90 (Fig. 21) is in an extended position so that liquid can be dispensed through the valve and the nozzle 28. Upon completion of a dispensing operation, the  
25 carbonation in the beverage returns the plunger assembly to the elevated, rest position. The cover 90 is slid upwardly on the nozzle 28, whereby the top wall 123 of the cover slides between that side 121 of the top wall 118 and the top wall 31

of the nozzle 28 to prevent downwardly movement of the plunger assembly 89.

While the nozzle 28 shown in Fig.28 includes vertical partitions 125, it will be appreciate that such parti-  
5 tions can be omitted. The cover 90 is slidably mounted on the nozzle 28 in essentially the same manner as in the other embodiments of the invention. As shown in Fig.21. arms 46 are provided on the cover 90 for sliding in the nozzle 28. Movement of the cover 90 is controlled  
10 by a projection 52 and the recesses 53 and 56. A rib 126 extends transversely of the top of the cover 90 facilitating fingertip movement of the cover.

With reference to Figs.29 to 37, a sixth embodiment of the cover device of the present invention includes a cap  
15 1 for mounting on the top end 2 of a bottle 3, a valve body 130, /Fig.33 and 34/ a plunger 26 with a top plate 118 separate from the valve body 130, where the top plate 118 is turnable to prevent the pressing of the plunger 26. The nozzle 28 leads into an annular groove 98  
20 surrounding the central opening 16, similarly to the fifth embodiment /Fig.31/. The inner surface of the top wall 7 defines a valve seat 24 around the said groove 98 and sleeve 112 extends downwardly as the continuation of the opening 16, which sleeve 112 comprises the bottom  
25 end of the plunger 26. The valve body 130 has a central recess 116 containing the end of the sleeve 112 and the plunger 26. Around the central recess 116 a valve surface 131 seals against the annular groove 98 and the



said valve seat 24, and an circular recess 133 surrounds them having an opening 135 in it to the opposite side of valve body 130 into downwardly extending sleeve 136 to retain the tube 4. The collar 132  
5 of the valve body 130 covers the whole inner surface of the top wall 7 inside of the cylindrical side wall 8.

On the top wall 31 of the nozzle 28 is projected an upwardly frame 144 to control the horizontal turning of the top plate 118 by a tongue 155 extending into said  
10 frame 144 and in the middle two stop means 142 and opposite with the frame 144 a deep-recess 141 with two half-recess 143 left and right side of it. On the bottom side of the top plate 118 are two lugs 154 and opposite with the tongue 155 an inwardly bulge 156. In the middle-  
15 position of the top plate 118 the lugs 154 are unhibited and the bulge 156 seats in the deep-recess 141, consequently the top plate 118 may press down for functioning the valve body 130. Turning on the top plate 118 to left or right about angular  $30^{\circ}$ , the lugs 154 are rested on  
20 the stop means 142 and the bulge 156 in one of the half-recess 143 hindering by them the pressing of the top plate 118 to prevent unauthorised operations.

An further preferred embodiment is shown on the Fig.30 of the device of our invention provided with an press-arm 160 over the nozzle 28. The press-arm 160 replaces  
25 the top plate 118, is conjoined with a hook 165 to a loop 127 can find on the opposite side of the cap 1 to the nozzle 28. The said press-arm 160 is elongated to

the discharge end 43 of the nozzle 28 and its outer closing wall 162 closes the nozzle 28 to prevent liquid drops. Pressing down the press-arm 160 they operate the plunger 26 and open the valve for liquid-flow, simultaneously the closing wall 162 moves down and the opening 161 comes before the discharge end 43. The lower edge 166 of the closing wall extending below the nozzle 28 is keeping the press-arm 160 in the closed position.

A preferred embodiment of the device of our invention in the inner side of the side wall 8 the inner thread is replaced with circular shoulder 170 with upwardly edge /Fig.37/, effected an without special tools non-releasable binding with the annular flange 11 of the outer side of the top end 2 of the bottle 3, accordingly to health hygenic inquires to prevent the unauthorised refilling of the container 3.

## C l a i m s

1. A cover and dispensing device for use on a container of liquid under pressure comprising cap means for mounting on the open top end of the container, a tubular nozzle means having an open outer end for discharging liquid, a channel between the nozzle and the container inside with an open bottom end for receiving fluid from the container, a valve seat means and valve body means for closing and opening the way of liquid through the said channel, characterized in that, the nozzle/28/ is on the upper side of the cap/1/ integral with circular top wall/7/ of the cap/1/, the cap/1/ includes cylindrical side wall/8/ making the sealing engagement on the open top end/2/ of the container/3/, and the said circular top wall/7/ has a central opening/16/ with an plunger/26/ of the valve body/5,88,130/ in it, where the valve seat/24/ is on the inner surface of said top wall/7/ around the inner end of central opening/16/ and the valve body /5, 88,130/ is arranged below the said inner surface of the top wall/7/ seals against the valve seat/24/.
2. The device according to claim 1, including a tube/4/ retained in a tubular cylindrical bottom section/18, 100,136/ of valve body/5,88,130/, and extending downwardly into liquid of the container/3/ for conveying the liquid into the nozzle/28/.

3. The device according to claim 1, wherein the nozzle/28/ extending upwardly on the top of the cap/1/ and from the bottle/3/, i.e. using the bottle/3/ inversely the nozzle /28/ extends downwardly.
4. The device according to any of the claims 1 - 3, wherein the top wall/7/ is provided downwardly with annular wall/13/ parallel to and substantially shorter than the side wall/8/ with them the said annular wall/13/ composes an inverted V-shaped recess/14/ to seal the top end/2/ of the bottle/3/ and with a sleeve/15/ as the downwardly extending of the inner open end of the central opening /16/ retained the valve body/5,88/ in it by friction.
5. The device according to claim 4, wherein the tubular nozzle/28/ has a top wall/31/ with resilient inner end covering the plunger/26/, whereby said inner end can be pressed against the plunger/26/ to open the valve means/5/.
6. The device according to claim 5, wherein the valve body/5/ has a tubular, cylindrical bottom section/18/ and an smaller diameter upper section including disc/23/ defining as the valve head and carrying the plunger/26/, and a plurality of resilient arms/22/ extend between said disc/23/ and the bottom section/18/ defining a cage-shape, and a flange/20/ on the bottom end to limit the upward movement, and inwardly shoulder/21/ to stop the tube/4/ on the upper end of the bottom section/18/.
7. The device according to claim 6, including a cover/36/ slidable on the top wall/31/ of the nozzle/28/ between

- a latch position when the cover/36/ preventing movement the resilient inner end of the nozzle/28/ and a release position permitting depression against the plunger/26/, having an outer end wall/41/ on the free end to close the discharge end/43/ of the nozzle/28/ in the latched position.
8. The device according to claim 4, wherein the inner end of the nozzle/28/ leads into an annular groove/98/ surrounding the central opening/16/, the valve head/107/ of the valve body/88/ seals against the inner end of said annular groove/98/ and has on its top an central recess /116/ comprising the short sleeve wall/112/ of the central opening/16/ and the bottom end of plunger/115/, the valve head/107/ is conjoined with resilient arms/106/ to the tubular cylindrical lower section/100/ resting on the bottom end of the sleeve/97/ of the groove/98/.
9. The device according to claim 8, wherein the sleeve/97/ of the groove/98/ has inner annular shoulder/101/ to rests the upper edges of the lower section/100/ of the valve body/88/ and the valve body/88/ is supplied with a thinner wall end/103/ may turn back inwardly the cylindrical section/100/ defining an inner case with the lugs/104/ extending inwardly in the rolled state stoping the tube/4/.
10. The device according to any of the claims 1 - 3, wherein the inner end of the nozzle/28/ leads into the annular groove/98/ surrounding the central opening/16/, and a valve body/130/ with his valve surface/131/ seals against the said groove/98/ and the valve seat/24/ around it, which valve body/130/ has a central recess/116/ compris-

ing the sleeve/112/ of the central opening/16/ and the bottom end of plunger/26/, surrounding with the said valve surface/131/ and as larger rounds with an circular recess/133/ and an collar /132/, the recess/133/ is supplied with an opening/135/ and with a sleeve/136/ under the opening/135/ on the opposite side of the valve body/130/, defined as the continuation downwardly of the opening/135/ for the tube/4/.

11. The device according to claim 10, wherein the plunger /26/ has a top plate/118/ with lugs/154/ seating on the stop means/142/ of the top wall/31/ of the nozzle/28/, and with bulge/156/ seating in one of half-recess/143/ on the nozzle/28/ in the latch position and with the bulge/156/ in the deep-recess/141/ and the lugs/154/ unhibited in the release position, preferably supplied with handle/153/ to check the top plate/118/ between the two position limited by an upwardly frame/144/ on the top wall/31/ of the nozzle/28/ comprises a horizontal extending tongue/155/ of top plate/118/ on the opposite side of the handle/153/.
12. The device according to claim 10, wherein the plunger /26/ is provided with a press-arm/160/ fixed one end of it with a hook/165/ to a loop/127/ of the cap/1/ and with other end defined closing wall/162/ closing the discharge end/43/ of nozzle/28/, and in pressed position an opening/161/ of the closing wall/162/ stands before the discharge end/43/ allowing the free outflow of the liquid.

13. The device according to any of the claims 1 - 11, wherein a pair of arcuate walls/60/ extending upwardly from opposite side of the top wall/7/.
14. The device according to any of the claims 1 - 13, includes a thin annular skirt/66/ extending downwardly from the bottom end of the side wall/8/ for sealing engagement with the neck/2/ of the bottle/3/, having a plurality of V-shaped grooves/67/ therein.
15. The device according to any of the claim 1 - 14, wherein the side wall/8/ has inner thread for sealing engagement with the open top end/2/ of the bottle/3/.
16. The device according to any of the claim 1 - 14, wherein the side wall/8/ has inner circular latch means /170/ preferably with upwardly edge against the annular flange/11/ of the outer side of the top end/2/ of the bottle/3/ making non-releasable binding with it.

## AMENDED CLAIMS

[received by the International Bureau on 6 October 1995 (06.10.95); original claim 1 amended; remaining claims unchanged (5 pages)]

1. A cover and dispensing device for use on a container of liquid under pressure comprising cap means for mounting on the open top end of the container, a tubular nozzle means having an open outer end for discharging liquid, a channel between the nozzle and the container inside with an open bottom end for receiving fluid from the container, a valve seat means and valve body means for closing and opening the way of liquid through the said channel, characterized in that, the nozzle/28/ is on the upper side of the cap/1/ integral with circular top wall/7/ of the cap/1/, the cap/1/ includes cylindrical side wall/8/ making the sealing engagement on the open top end/2/ of the container/3/, and the said circular top wall/7/ has a central opening/16/ with a plunger/26/ of the valve body/5,88,130/ in it, where the valve seat/24/ is on the inner surface of said top wall/7/ around the inner end of central opening/16/ and the valve body/5,88,130/ is arranged below the said inner surface of the top wall/7/ seales against the valve seat/24/, wherein the functions to seal the valve seat/24/ and to retain and seal the straw-tube/4/ are contracted in the same structural unit of the cap/1/, i.e. in the valve body/5,88,130/,



which may open by the plunger/26/ and will be closed -- without any spring means -- by effect of inner gaspressure of liquid content of the container/3/.

2. The device according to claim 1, including a tube/4/ retained in a tubular cylindrical bottom section/18, 100,136/ of valve body/5,88,130/, and extending downwardly into liquid of the container/3/ for conveying the liquid into the nozzle/28/.
3. The device according to claim 1, wherein the nozzle/28/ extending upwardly on the top of the cap/1/ and from the bottle/3/, i.e. using the bottle/3/ inversely the nozzle /28/ extends downwardly.
4. The device according to any of the claims 1 - 3, wherein the top wall/7/ is provided downwardly with annular wall/13/ parallel to and substantially shorter than the side wall/8/ with them the said annular wall/13/ composes an inverted V-shaped recess/14/ to seal the top end/2/ of the bottle/3/ and with a sleeve/15/ as the downwardly extending of the inner open end of the central opening /16/ retained the valve body/5,88/ in it by friction.
5. The device according to claim 4, wherein the tubular nozzle/28/ has a top wall/31/ with resilient inner end covering the plunger/26/, whereby said inner end can be pressed against the plunger/26/ to open the valve means/5/.
6. The device according to claim 5, wherein the valve body/5/ has a tubular, cylindrical bottom section/18/ and an smaller diameter upper section including disc/23/ de-

fining as the valve head and carrying the plunger/26/, and a plurality of resilient arms/22/ extend between said disc/23/ and the bottom section/18/ defining a cage-shape, and a flange/20/ on the bottom end to limit the upward movement, and inwardly shoulder/21/ to stop the tube/4/ on the upper end of the bottom section/18/.

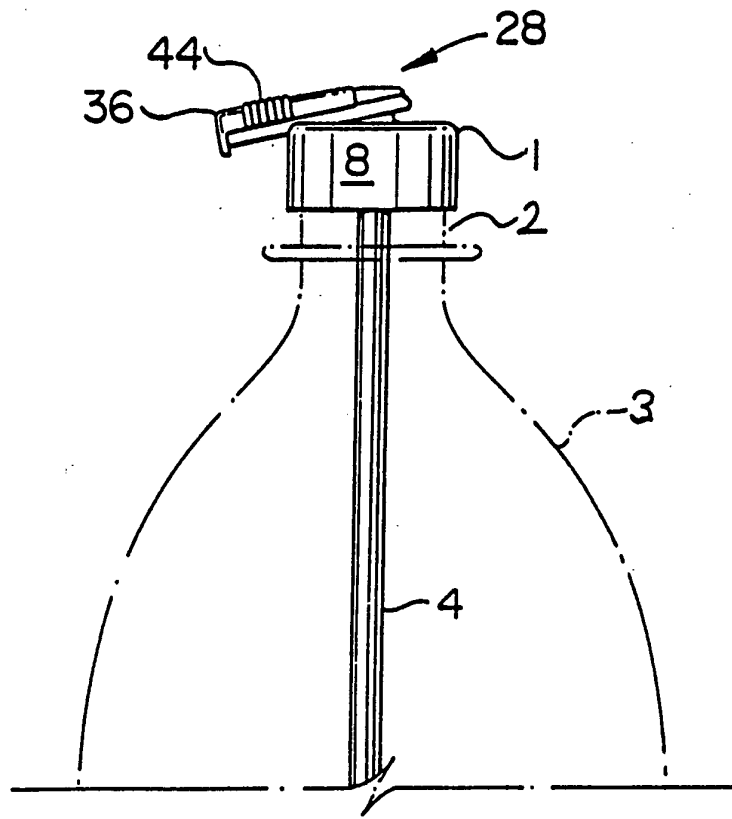
7. The device according to claim 6, including a cover/36/ slidable on the top wall/31/ of the nozzle/28/ between a latch position when the cover/36/ preventing movement the resilient inner end of the nozzle/28/ and a release position permitting depression against the plunger/26/, having an outer end wall/41/ on the free end to close the discharge end/43/ of the nozzle/28/ in the latched position.
8. The device according to claim 4, wherein the inner end of the nozzle/28/ leads into an annular groove/98/ surrounding the central opening/16/, the valve head/107/ of the valve body/88/ seals against the inner end of said annular groove/98/ and has on its top an central recess /116/ comprising the short sleeve wall/112/ of the central opening/16/ and the bottom end of plunger/115/, the valve head/107/ is conjoined with resilient arms/106/ to the tubular cylindrical lower section/100/ resting on the bottom end of the sleeve/97/ of the groove/98/.
9. The device according to claim 8, wherein the sleeve/97/ of the groove/98/ has inner annular shoulder/101/ to rests the upper edges of the lower section/100/ of the valve body/88/ and the valve body/88/ is supplied with a thin-

- ner wall end/103/ may turn back inwardly the cylindrical section/100/ defining an inner case with the lugs/104/ extending inwardly in the rolled state stoping the tube/4/.
10. The device according to any of the claims 1 - 3, wherein the inner end of the nozzle/28/ leads into the annular groove/98/ surrounding the central opening/16/, and a valve body/130/ with his valve surface/131/ seals against the said groove/98/ and the valve seat/24/ around it, which valve body/130/ has a central recess/116/ comprising the sleeve/112/ of the central opening/16/ and the bottom end of plunger/26/, surrounding with the said valve surface/131/ and as larger rounds with an circular recess/133/ and an collar /132/, the recess/133/ is supplied with an opening/135/ and with a sleeve/136/ under the opening/135/ on the opposite side of the valve body/130/, defined as the continuation downwardly of the opening/135/ for the tube/4/.
11. The device according to claim 10, wherein the plunger /26/ has a top plate/118/ with lugs/154/ seating on the stop means/142/ of the top wall/31/ of the nozzle/28/, and with bulge/156/ seating in one of half-recess/143/ on the nozzle/28/ in the latch position and with the bulge/156/ in the deep-recess/141/ and the lugs/154/ unhibited in the release position, preferably supplied with handle/153/ to check the top plate/118/ between the two position limited by an upwardly frame/144/ on the top wall/31/ of the nozzle/28/ comprises a horizon-

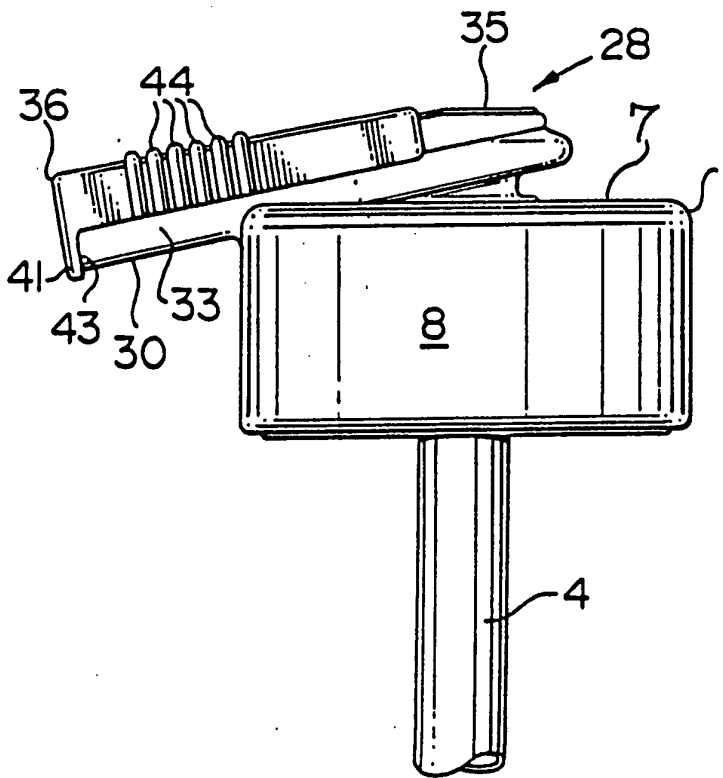
tal extending tongue/155/ of top plate/118/ on the opposite side of the handle/153/.

12. The device according to claim 10, wherein the plunger /26/ is provided with a press-arm/160/ fixed one end of it with a hook/165/ to a loop/127/ of the cap/1/ and with other end defined closing wall/162/ closing the discharge end/43/ of nozzle/28/, and in pressed position an opening/161/ of the closing wall/162/ stands before the discharge end/43/ allowing the free outflow of the liquid.
13. The device according to any of the claims 1 - 11, wherein a pair of arcuate walls/60/ extending upwardly from opposite side of the top wall/7/.
14. The device according to any of the claims 1 - 13, includes a thin annular skirt/66/ extending downwardly from the bottom end of the side wall/8/ for sealing engagement with the neck/2/ of the bottle/3/, having a plurality of V-shaped grooves/67/ therein.
15. The device according to any of the claim 1 - 14, wherein the side wall/8/ has inner thread for sealing engagement with the open top end/2/ of the bottle/3/.
16. The device according to any of the claim 1 - 14, wherein the side wall/8/ has inner circular latch means /170/ preferably with upwardly edge against the annular flange/11/ of the outer side of the top end/2/ of the bottle/3/ making non-releasable binding with it.

1/17

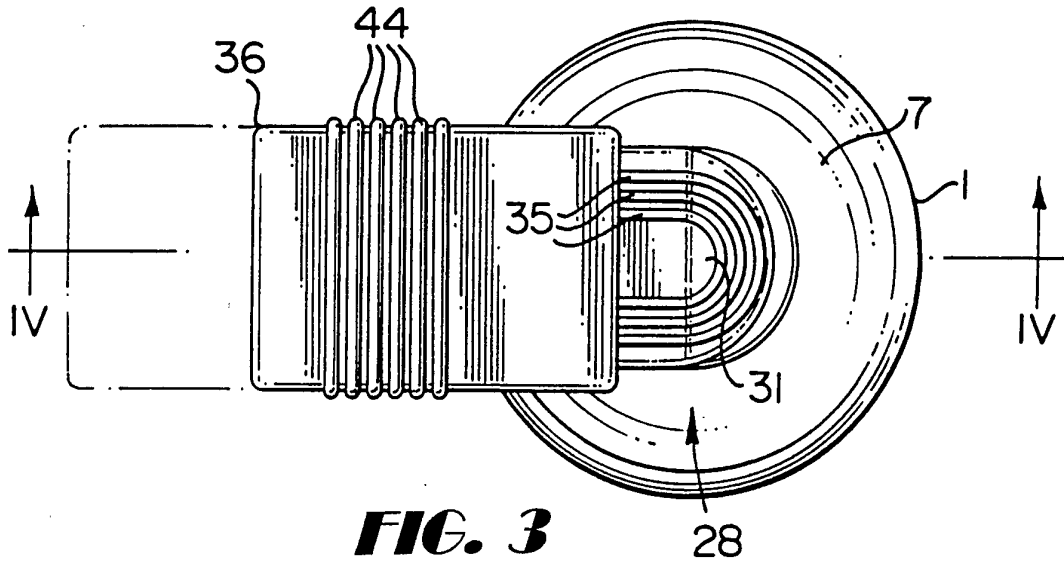


**FIG. 1**

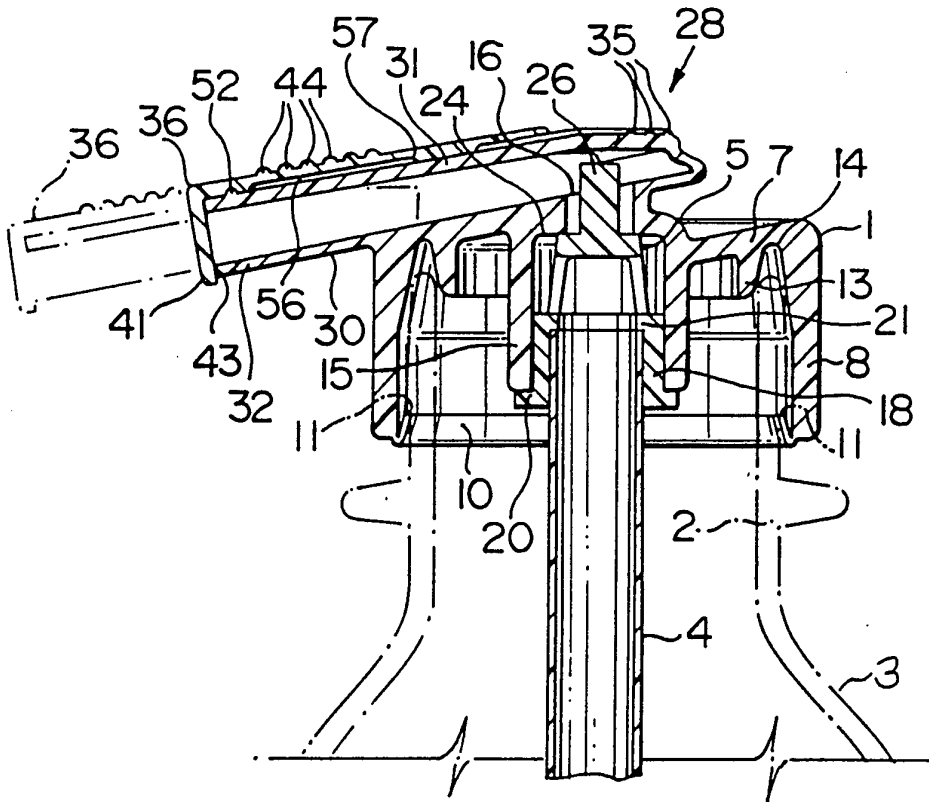


**FIG. 2**

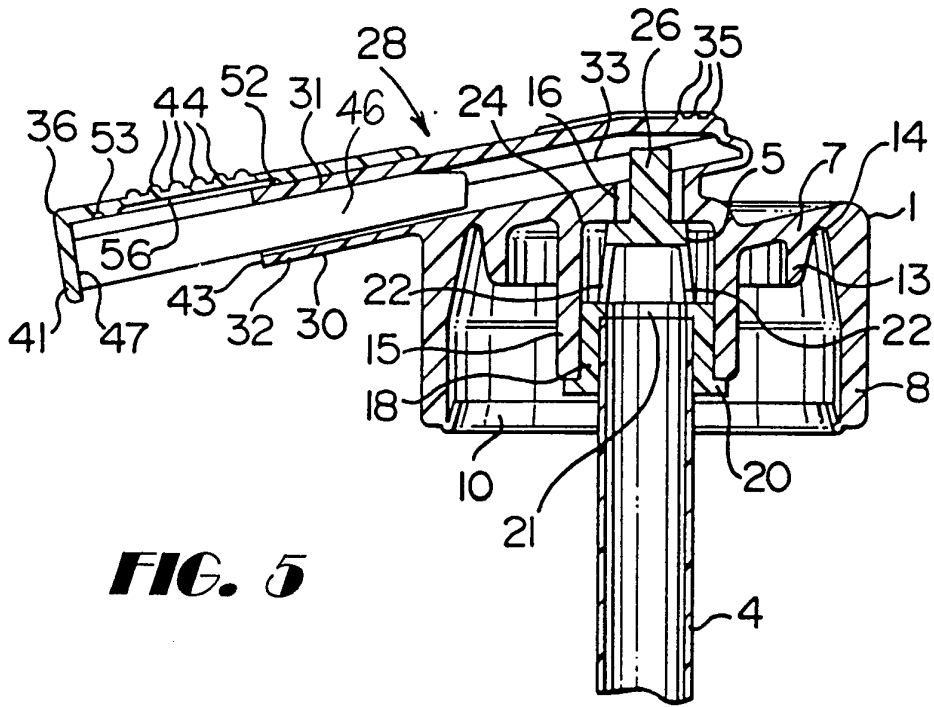
2/17



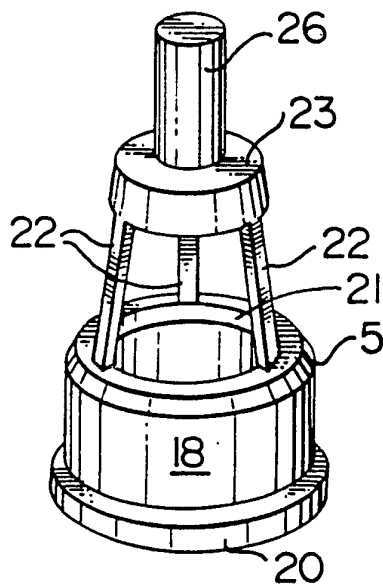
**FIG. 3**



**FIG. 4**

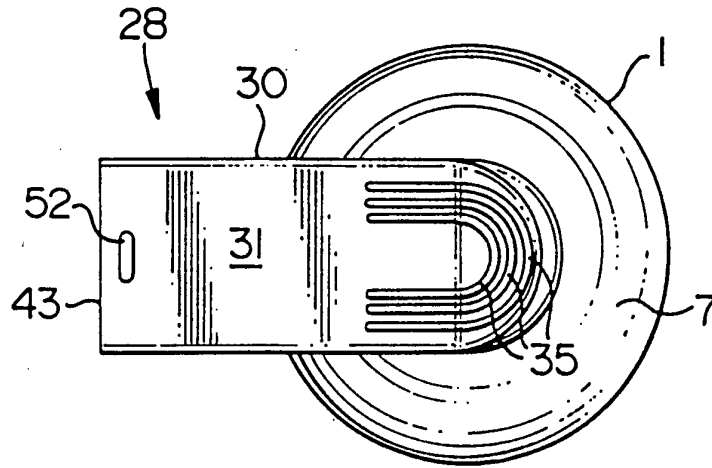


**FIG. 5**

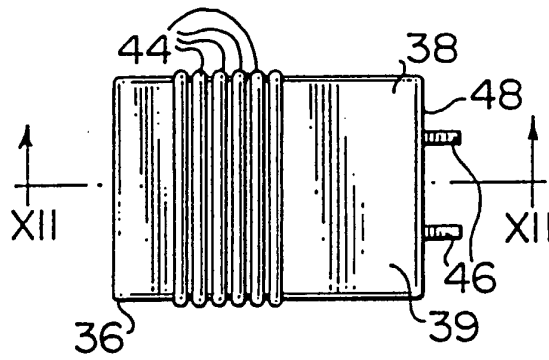


**FIG. 6**

4/17



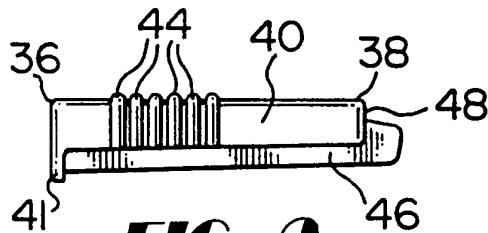
**FIG. 7**



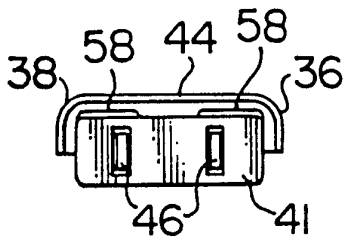
**FIG. 8**



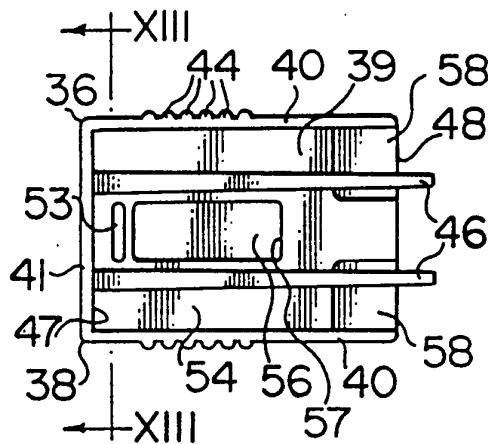
5/17



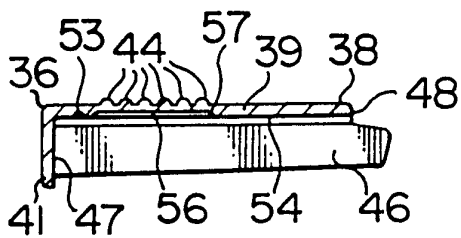
**FIG. 9**



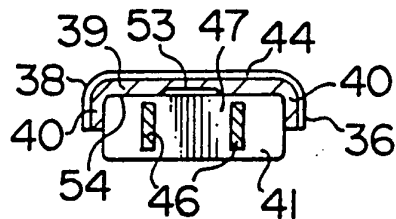
**FIG. 10**



**FIG. 11**

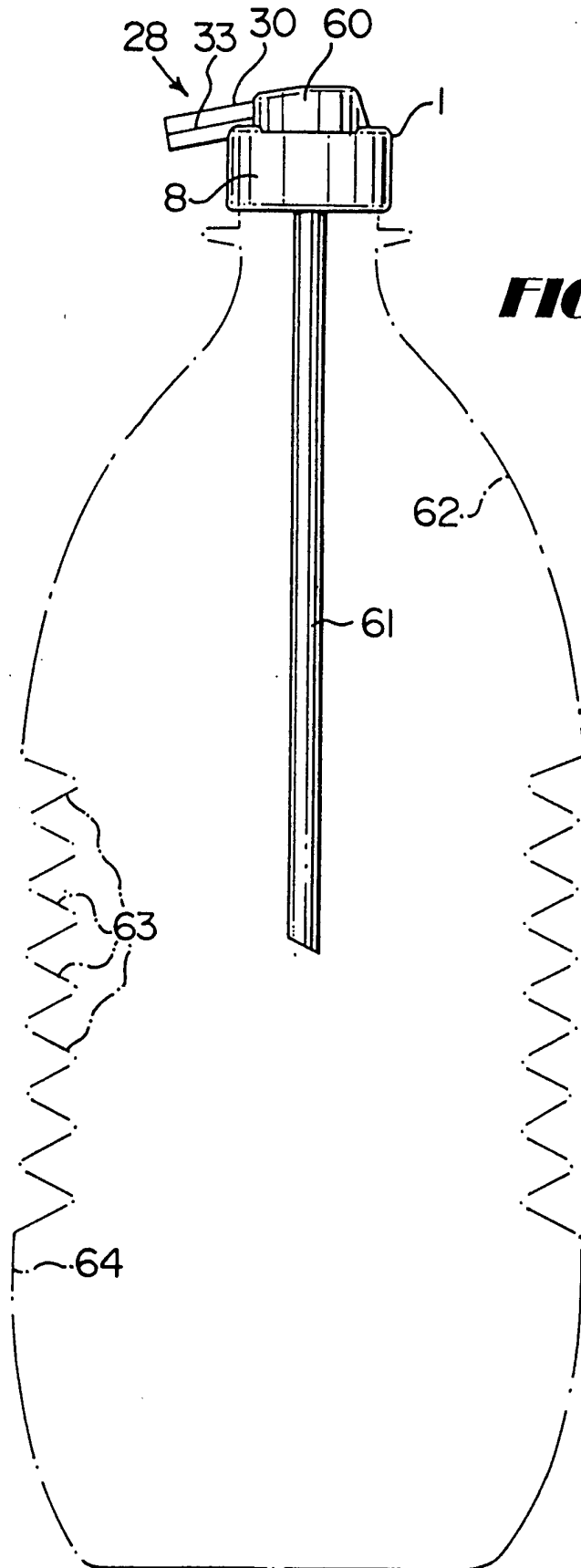


**FIG. 12**

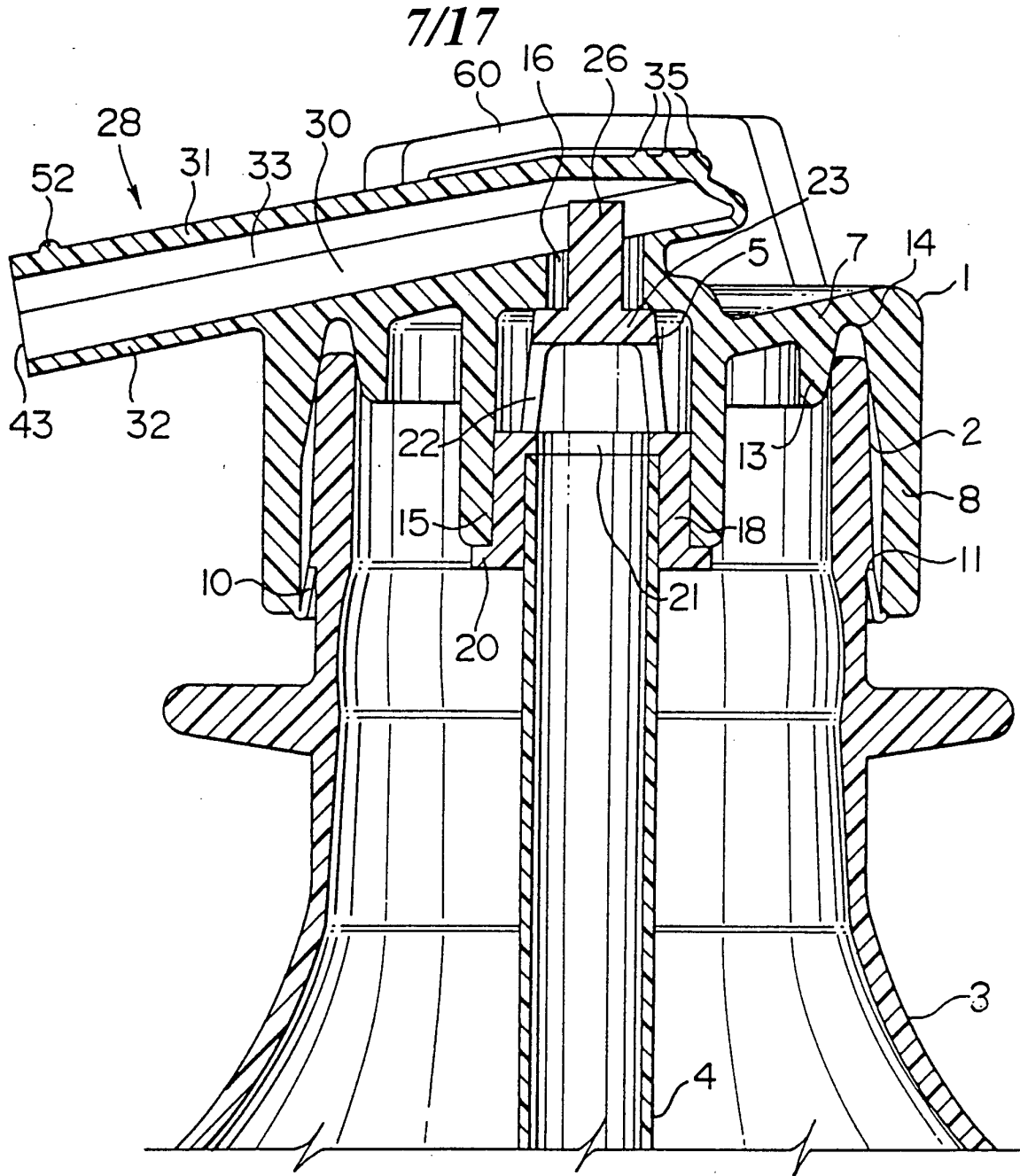


**FIG. 13**

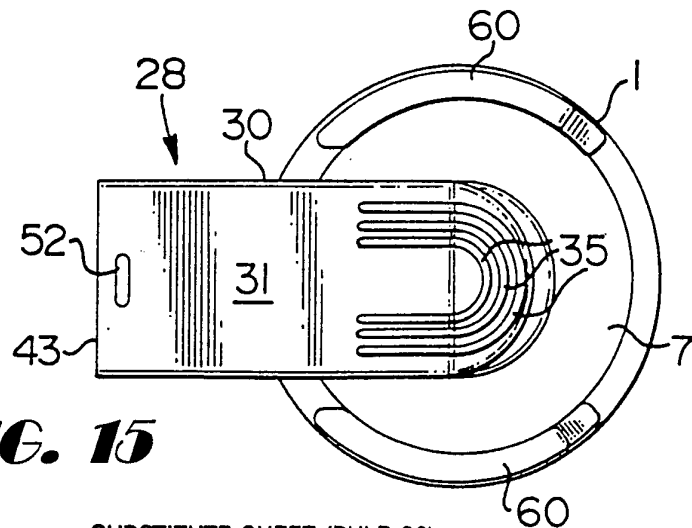
6/17



**FIG. 14**

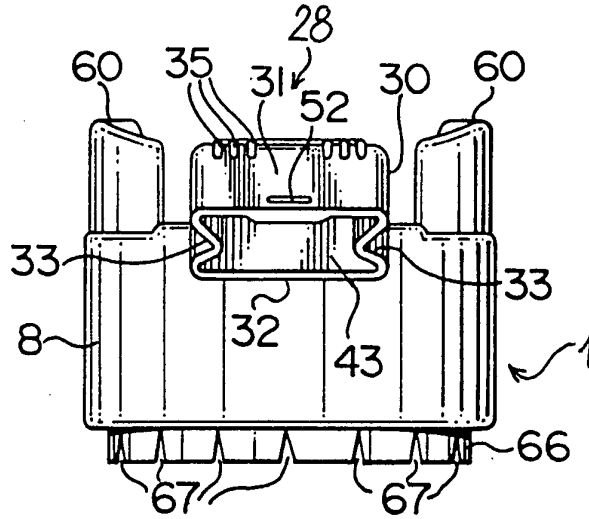


**FIG. 16**

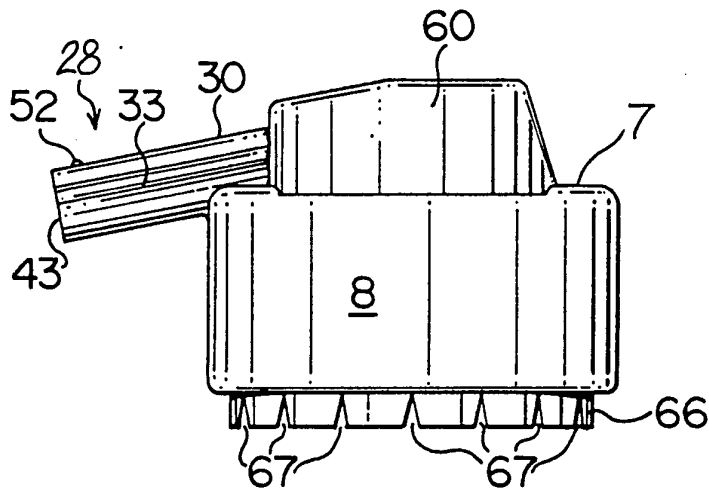


**FIG. 15**

8/17

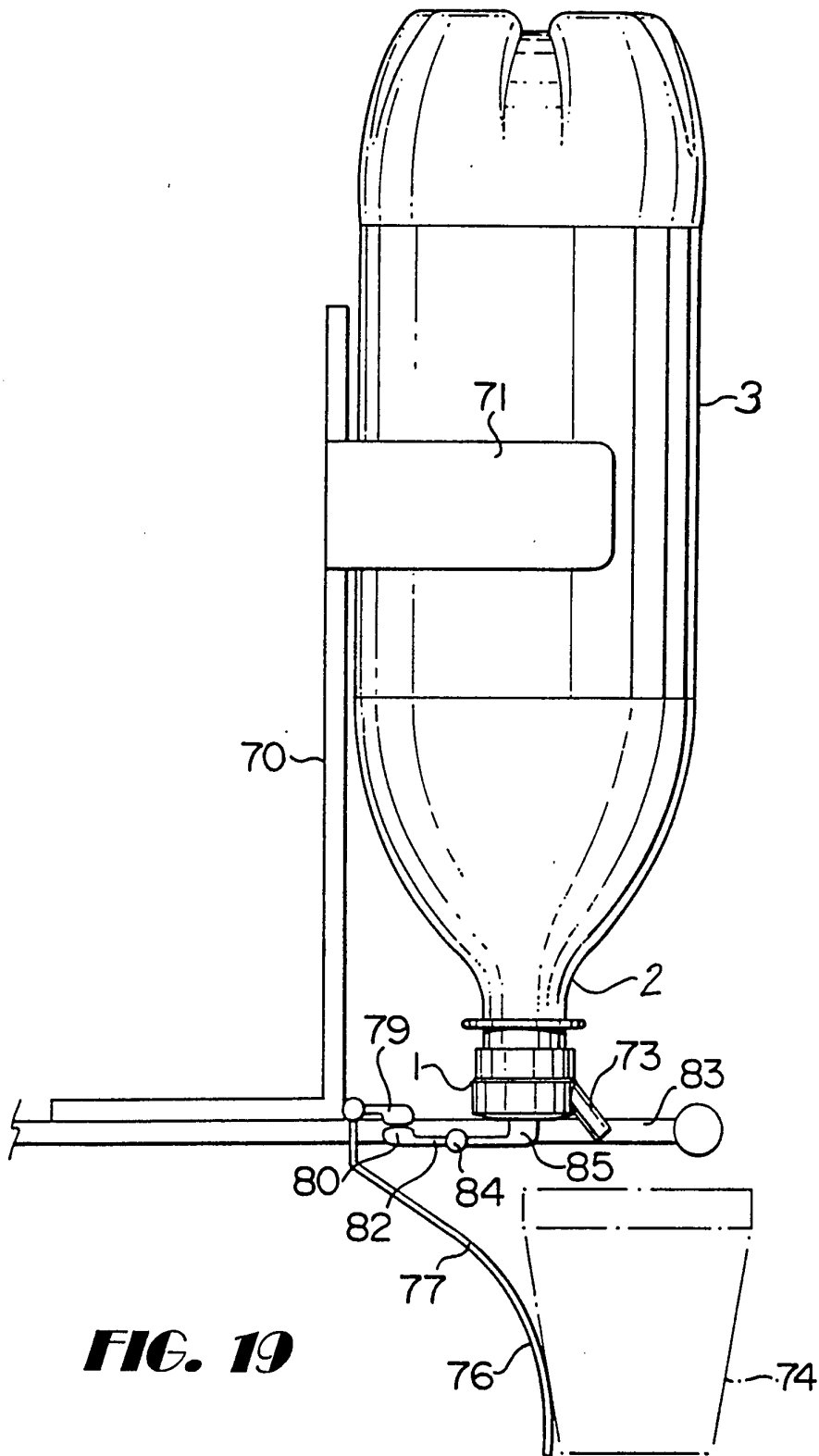


**FIG. 18**



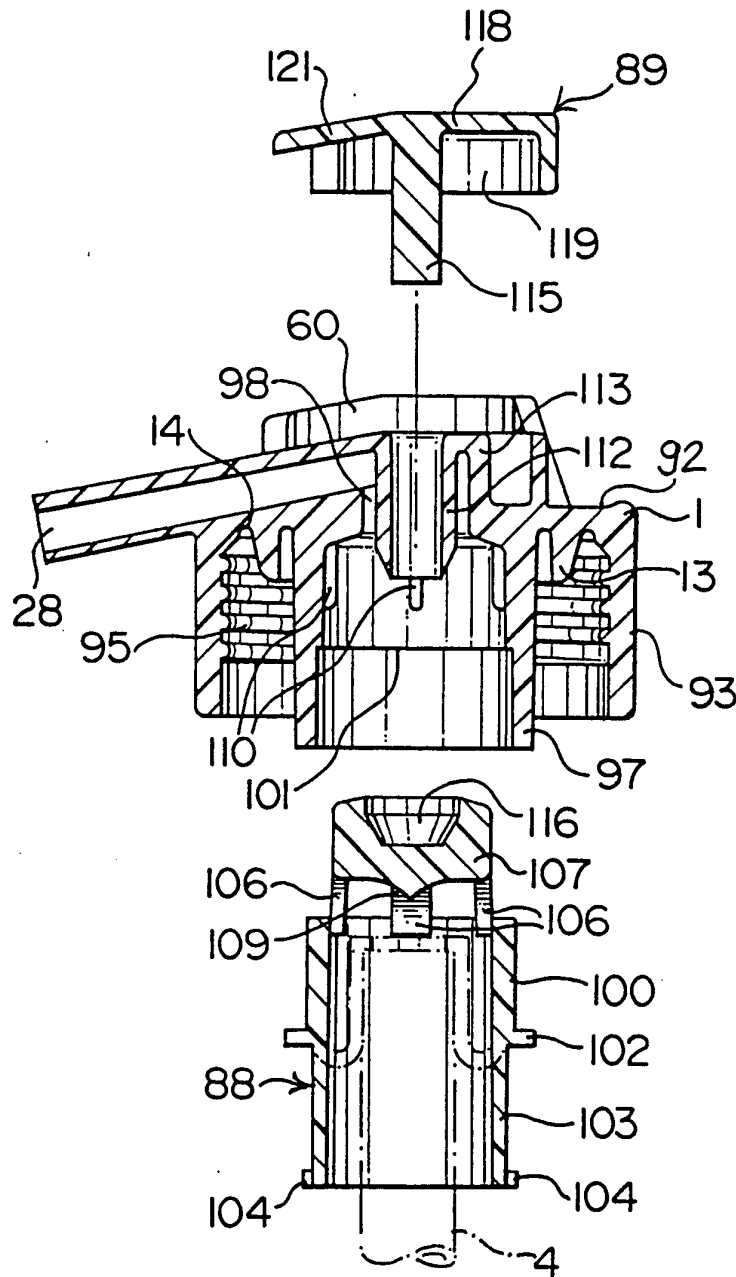
**FIG. 17**

9/17



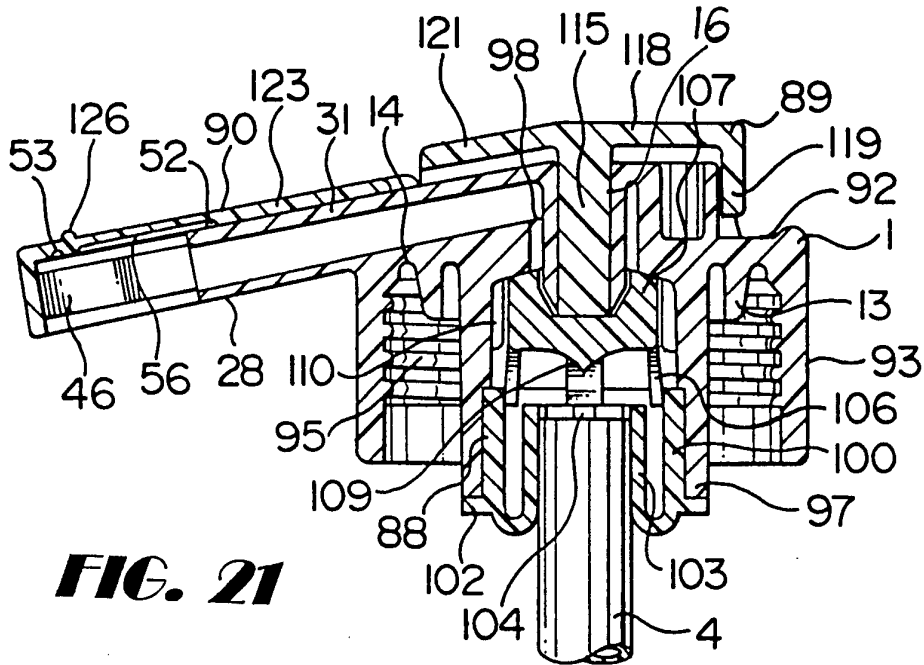
**FIG. 19**

10/17

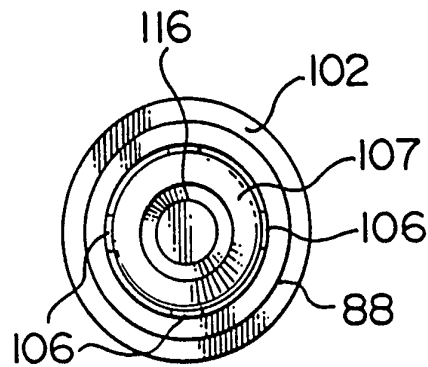


**FIG. 20**

11/17

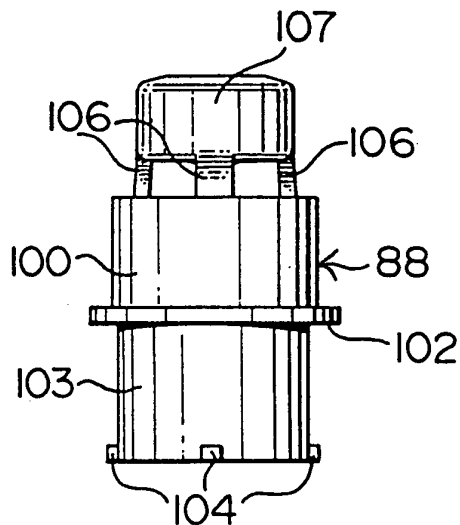


**FIG. 21**

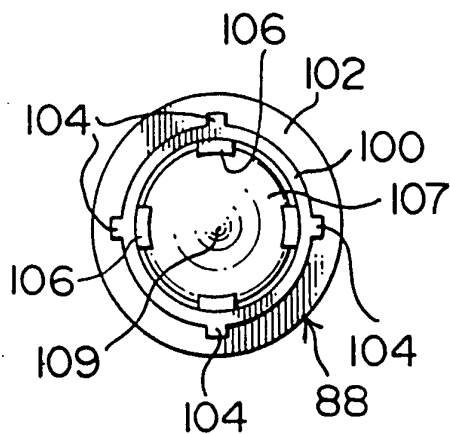


**FIG. 22**

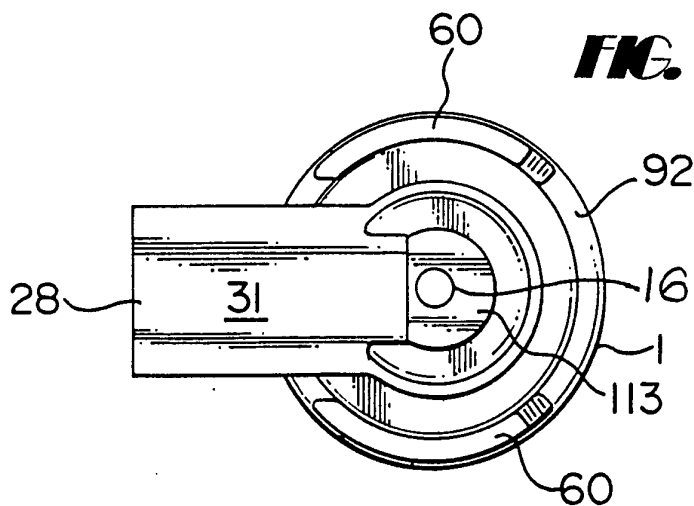
12/17



**FIG. 23**



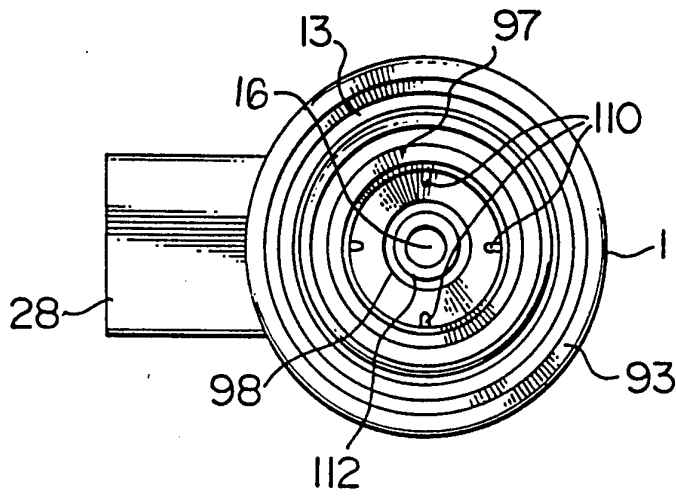
**FIG. 24**



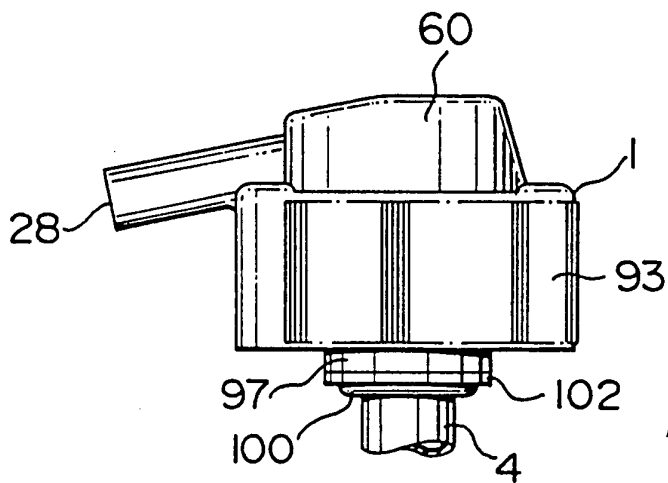
**FIG. 25**



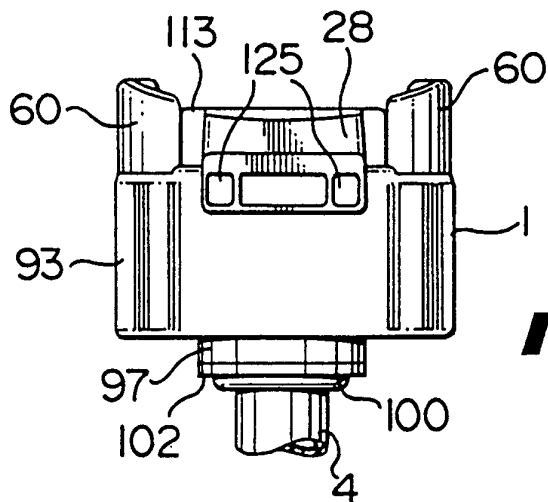
13/17



**FIG. 26**

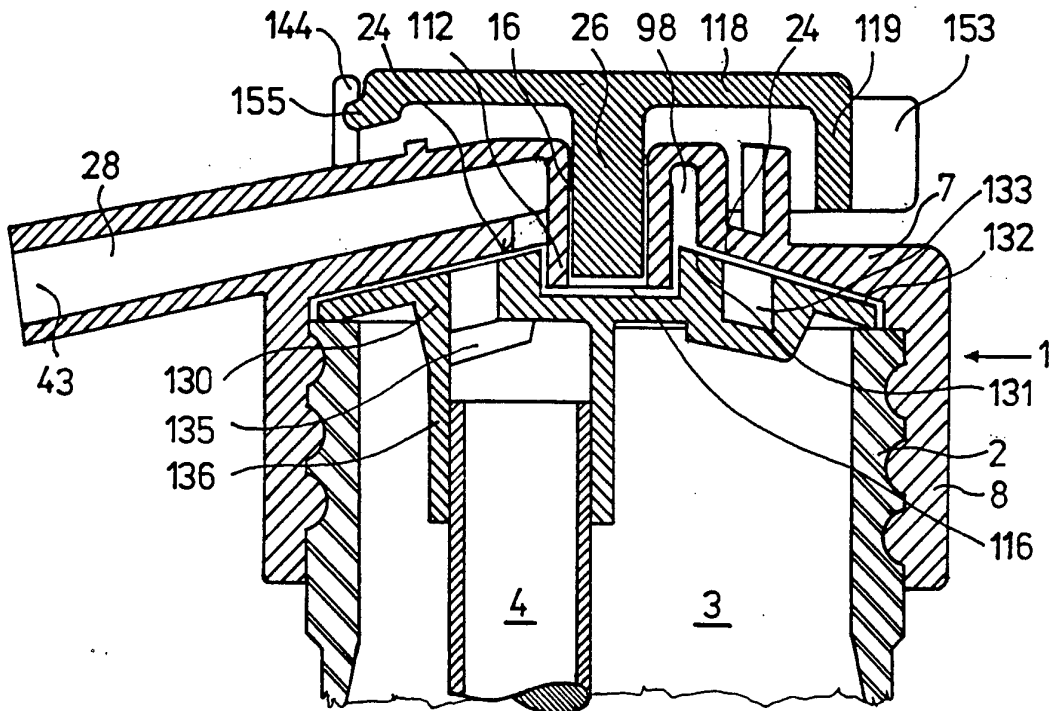


**FIG. 27**

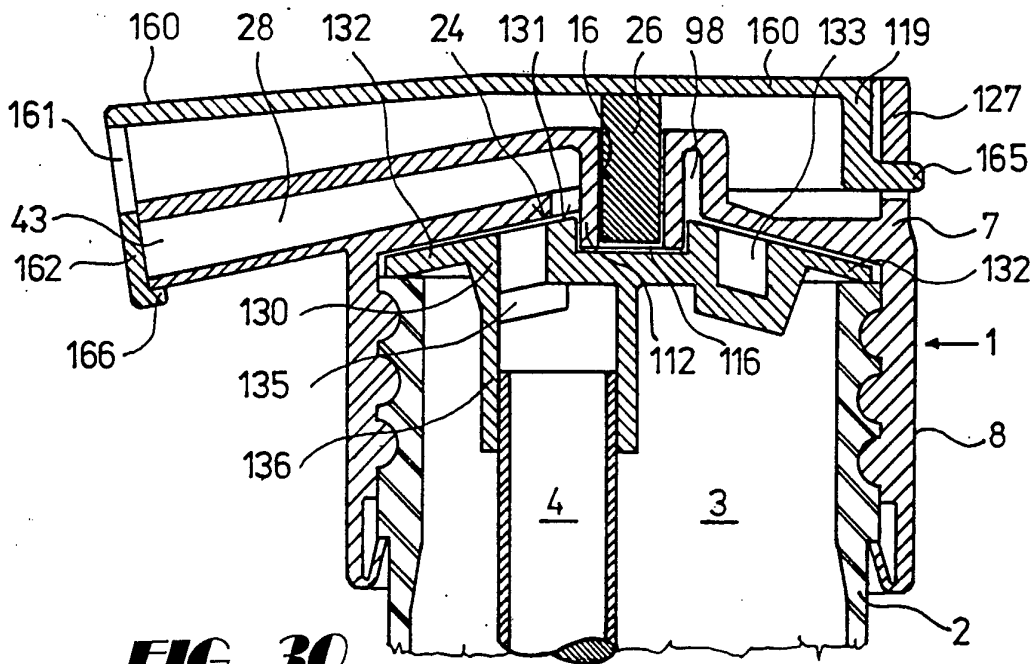


**FIG. 28**

14/17

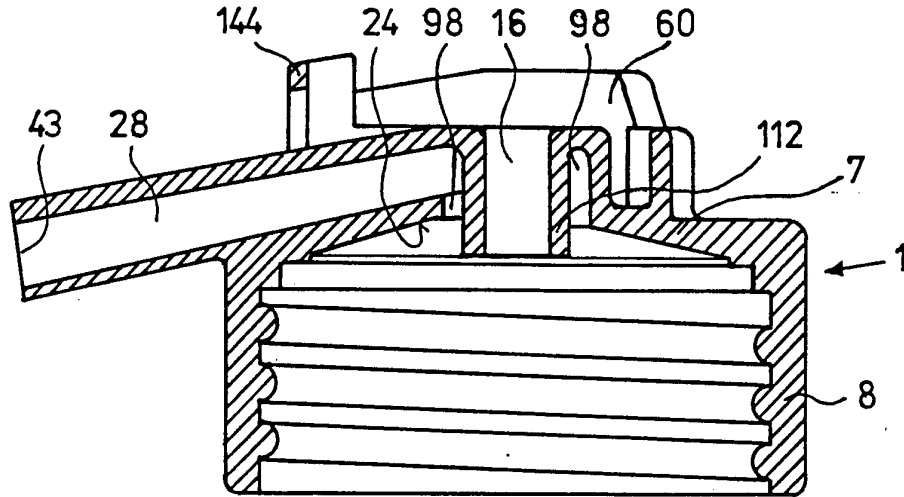


**FIG. 29**

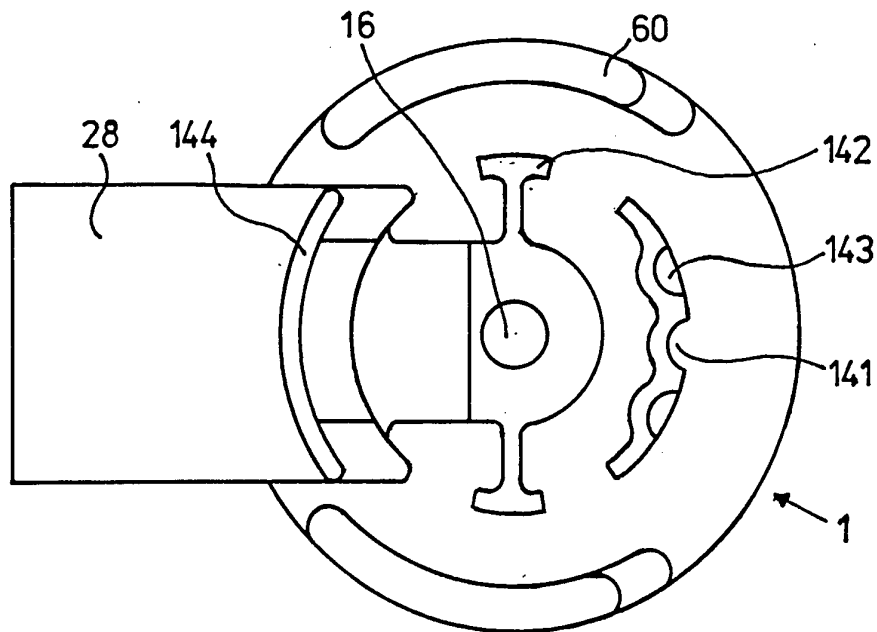


**FIG. 30**

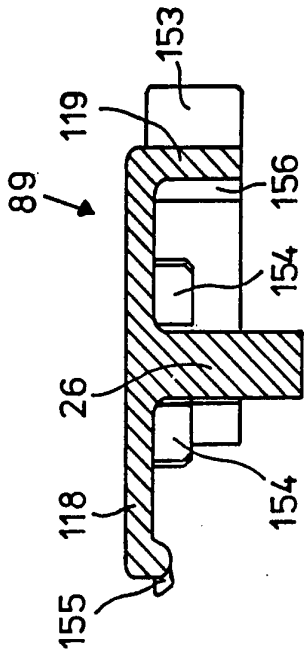
15/17



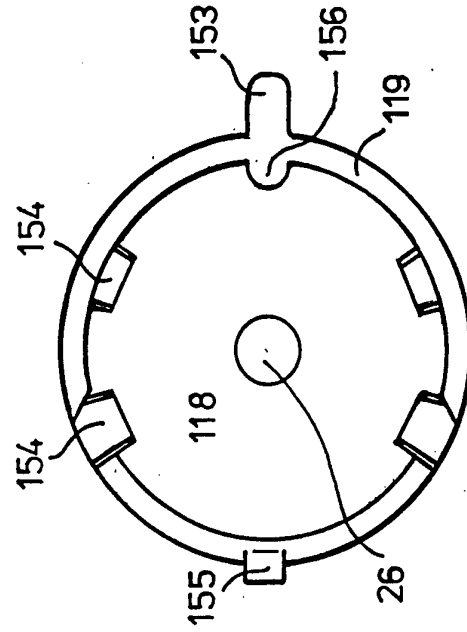
**FIG. 31**



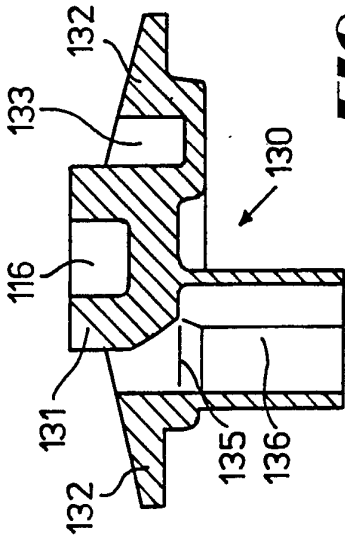
**FIG. 32**



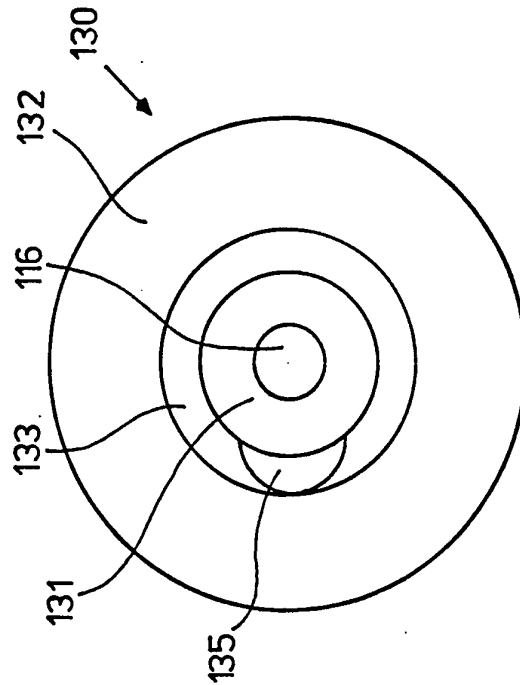
**FIG. 35**



**FIG. 36**

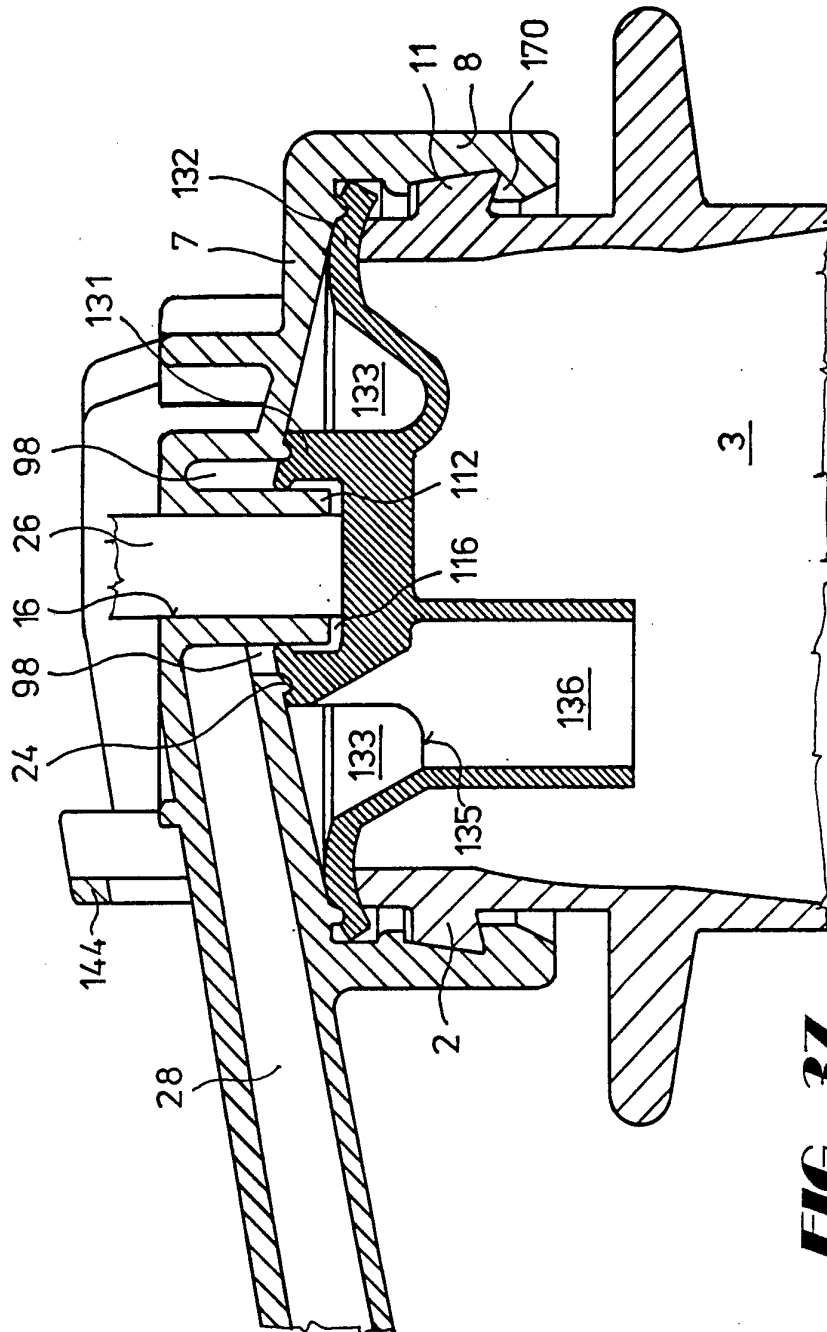


**FIG. 33**



**FIG. 34**

17/17



**FIG. 37**

# INTERNATIONAL SEARCH REPORT

International Application No

PCT/IB 95/00321

A. CLASSIFICATION OF SUBJECT MATTER  
 IPC 6 B67D1/04 B65D83/16

According to International Patent Classification (IPC) or to both national classification and IPC

**B. FIELDS SEARCHED**

Minimum documentation searched (classification system followed by classification symbols)  
 IPC 6 B67D B65D

Documentation searched other than minimum documentation to the extent that such documents are included in the fields searched

Electronic data base consulted during the international search (name of data base and, where practical, search terms used)

**C. DOCUMENTS CONSIDERED TO BE RELEVANT**

Category *	Citation of document, with indication, where appropriate, of the relevant passages	Relevant to claim No.
X	FR,A,1 380 581 (GIROUD) 12 March 1965  see page 1, column 1, line 28 - page 2, column 1, line 8; figure 1 ---	1-3, 14-16
A	FR,A,2 537 092 (PELECQ) 8 June 1984 ---	
A	FR,A,1 389 863 (RINGENBACH) 11 June 1965 ---	
A	WO,A,92 00231 (MCKESSON CORP.) 9 January 1992 ---	
A	EP,A,0 420 561 (LAWSON MARDON GROUP) 3 April 1991 -----	

Further documents are listed in the continuation of box C.

Patent family members are listed in annex.

\* Special categories of cited documents :

- "A" document defining the general state of the art which is not considered to be of particular relevance
- "E" earlier document but published on or after the international filing date
- "L" document which may throw doubts on priority claim(s) or which is cited to establish the publication date of another citation or other special reason (as specified)
- "O" document referring to an oral disclosure, use, exhibition or other means
- "P" document published prior to the international filing date but later than the priority date claimed

- "T" later document published after the international filing date or priority date and not in conflict with the application but cited to understand the principle or theory underlying the invention
- "X" document of particular relevance; the claimed invention cannot be considered novel or cannot be considered to involve an inventive step when the document is taken alone
- "Y" document of particular relevance; the claimed invention cannot be considered to involve an inventive step when the document is combined with one or more other such documents, such combination being obvious to a person skilled in the art.
- "&" document member of the same patent family

Date of the actual completion of the international search

7 August 1995

Date of mailing of the international search report

14. 08. 95

Name and mailing address of the ISA

European Patent Office, P.B. 5818 Patentlaan 2  
 NL - 2280 HV Rijswijk  
 Tel. ( + 31-70) 340-2040, Tx. 31 651 cpo nl,  
 Fax: ( + 31-70) 340-3016

Authorized officer

J.-P. Deutsch

# INTERNATIONAL SEARCH REPORT

Information on patent family members

International Application No

PCT/IB 95/00321

Patent document cited in search report	Publication date	Patent family member(s)	Publication date
FR-A-1380581	12-03-65	NONE	
FR-A-2537092	08-06-84	NONE	
FR-A-1389863	11-06-65	NONE	
WO-A-9200231	09-01-92	AU-A- 8181991	23-01-92
EP-A-420561	03-04-91	GB-A- 2237605	08-05-91