

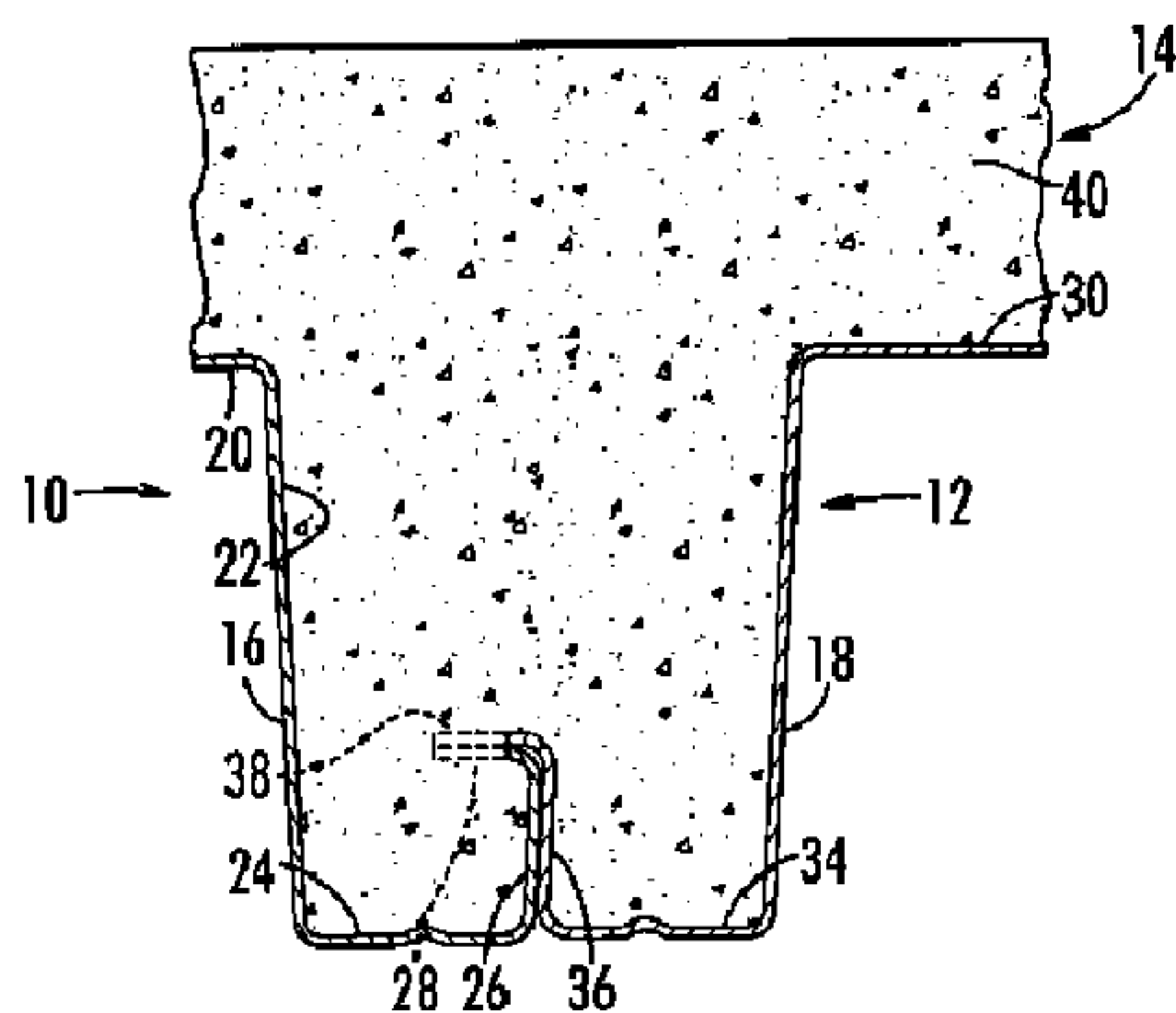

(86) Date de dépôt PCT/PCT Filing Date: 2007/10/15  
 (87) Date publication PCT/PCT Publication Date: 2009/04/23  
 (45) Date de délivrance/Issue Date: 2013/04/30  
 (85) Entrée phase nationale/National Entry: 2010/04/14  
 (86) N° demande PCT/PCT Application No.: US 2007/081441  
 (87) N° publication PCT/PCT Publication No.: 2009/051589

(51) Cl.Int./Int.Cl. *E04B 5/40* (2006.01),  
*E04B 1/16* (2006.01)  
 (72) Inventeur/Inventor:  
COLLINS, HARRY, US  
 (73) Propriétaire/Owner:  
CONSOLIDATED SYSTEMS, INC., US  
 (74) Agent: R. WILLIAM WRAY & ASSOCIATES

(54) Titre : SYSTEME DE PONT COMPOSITE  
 (54) Title: COMPOSITE DECK SYSTEM



**A**

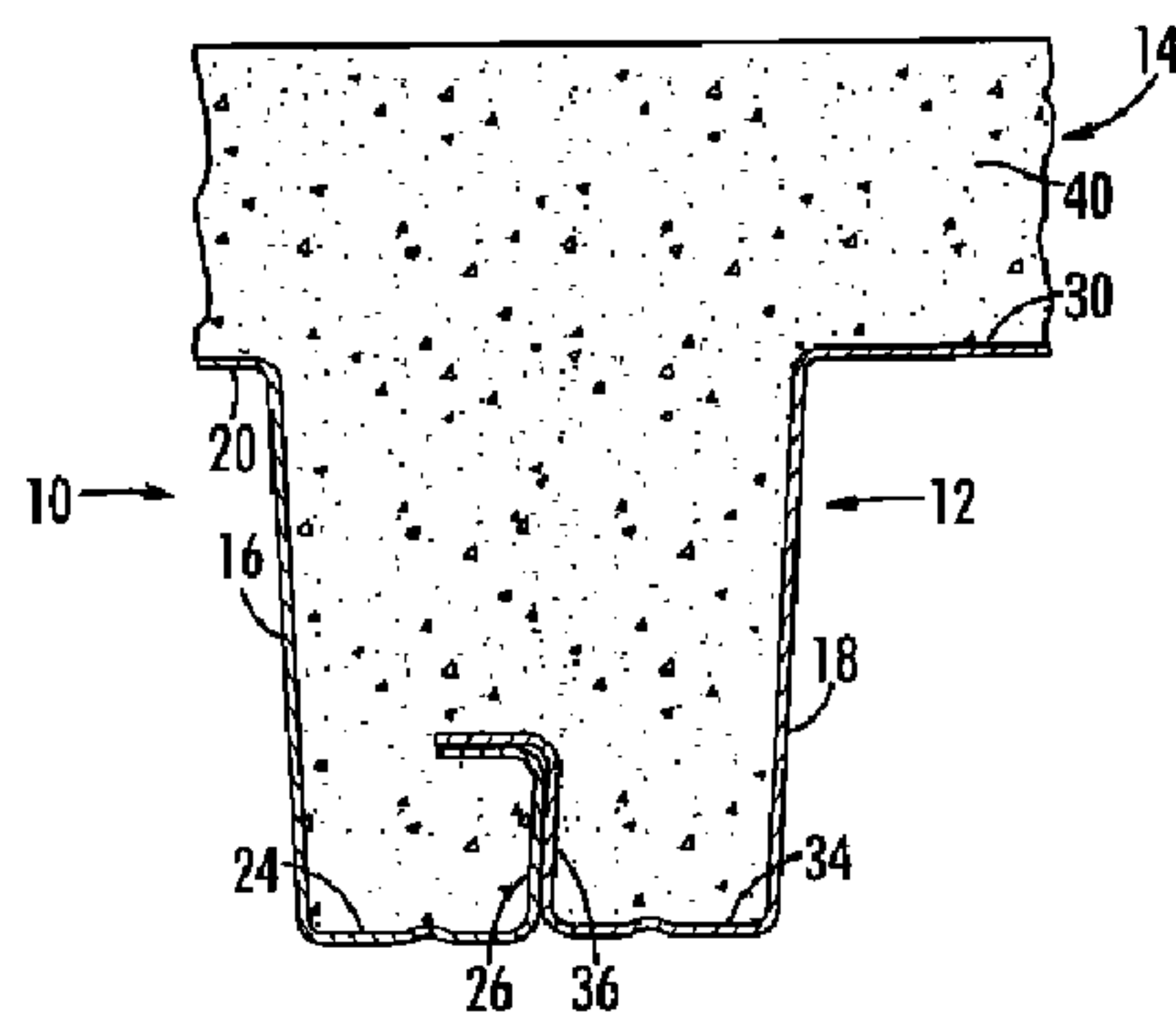

**B**

(57) Abrégé/Abstract:

A composite deck system having a deck component and a concrete component. The deck component of the present invention includes deck sections, each having a longitudinally-extending rib with spaced apart sidewalls connected to a top wall. At the

(57) **Abrégé(suite)/Abstract(continued):**

opposing ends of the sidewalls can be included side edges or webs having upturned flanges with an opening or openings along the flanges that are dimensioned to facilitate composite action between the deck sections and the concrete. The system includes a first deck section, as described, adjacent to a second deck section, wherein the side edges of the first and second deck sections are in juxtaposed relation. These deck sections can be combined with concrete to form a composite deck.

(12) INTERNATIONAL APPLICATION PUBLISHED UNDER THE PATENT COOPERATION TREATY (PCT)

(19) World Intellectual Property Organization  
International Bureau(43) International Publication Date  
23 April 2009 (23.04.2009)

PCT

(10) International Publication Number  
**WO 2009/051589 A1**(51) International Patent Classification:  
*E04B 1/16* (2006.01)

(21) International Application Number:

PCT/US2007/081441

(22) International Filing Date: 15 October 2007 (15.10.2007)

(25) Filing Language: English

(26) Publication Language: English

(63) Related by continuation (CON) or continuation-in-part (CIP) to earlier application:

US 11/333,839 (CIP)  
Filed on 17 January 2006 (17.01.2006)(71) Applicant (for all designated States except US): **CONSOLIDATED SYSTEMS, INC.** [US/US]; 650 Rosewood Drive, Columbia, South Carolina 29201 (US).

(72) Inventor; and

(75) Inventor/Applicant (for US only): **COLLINS, Harry** [US/US]; 2400 Devine Street, Suite K, Columbia, South Carolina 29205 (US).(74) Agents: **HARDAWAY, John B., III** et al.; Nexsen Pruet Adams Kleemeier LLC, P.O. Drawer 10648, Greenville, South Carolina 29603 (US).

(81) Designated States (unless otherwise indicated, for every kind of national protection available): AE, AG, AL, AM, AT, AU, AZ, BA, BB, BG, BH, BR, BW, BY, BZ, CA, CH, CN, CO, CR, CU, CZ, DE, DK, DM, DO, DZ, EC, EE, EG, ES, FI, GB, GD, GE, GH, GM, GT, HN, HR, HU, ID, IL, IN, IS, JP, KE, KG, KM, KN, KP, KR, KZ, LA, LC, LK, LR, LS, LT, LU, LY, MA, MD, ME, MG, MK, MN, MW, MX, MY, MZ, NA, NG, NI, NO, NZ, OM, PG, PH, PL, PT, RO, RS, RU, SC, SD, SE, SG, SK, SL, SM, SV, SY, TJ, TM, TN, TR, TT, TZ, UA, UG, US (patent), UZ, VC, VN, ZA, ZM, ZW.

(84) Designated States (unless otherwise indicated, for every kind of regional protection available): ARIPO (BW, GH, GM, KE, LS, MW, MZ, NA, SD, SL, SZ, TZ, UG, ZM, ZW), Eurasian (AM, AZ, BY, KG, KZ, MD, RU, TJ, TM), European (AT, BE, BG, CH, CY, CZ, DE, DK, EE, ES, FI, FR, GB, GR, HU, IE, IS, IT, LT, LU, LV, MC, MT, NL, PL,

[Continued on next page]

(54) Title: COMPOSITE DECK SYSTEM

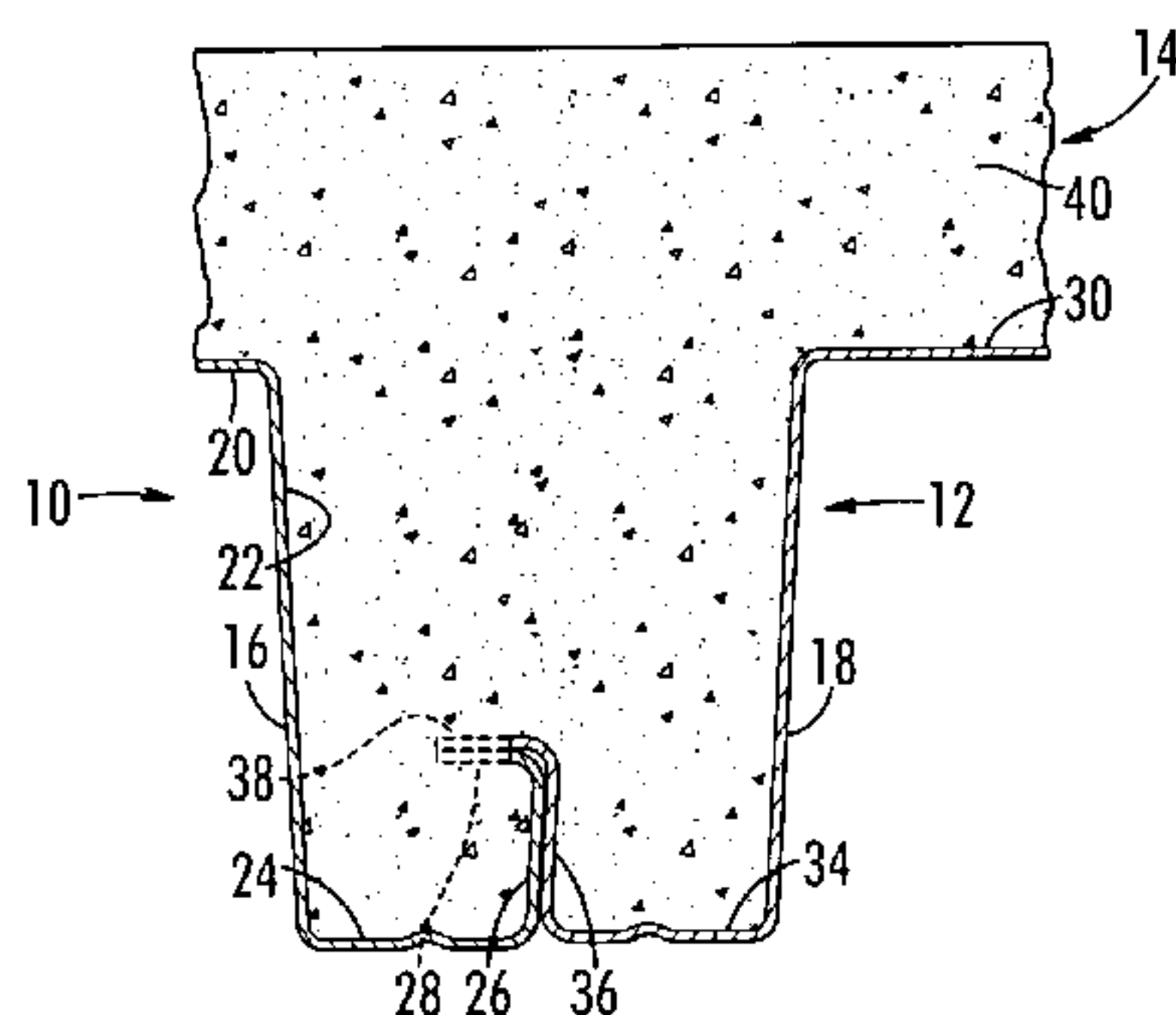

FIG. 1A

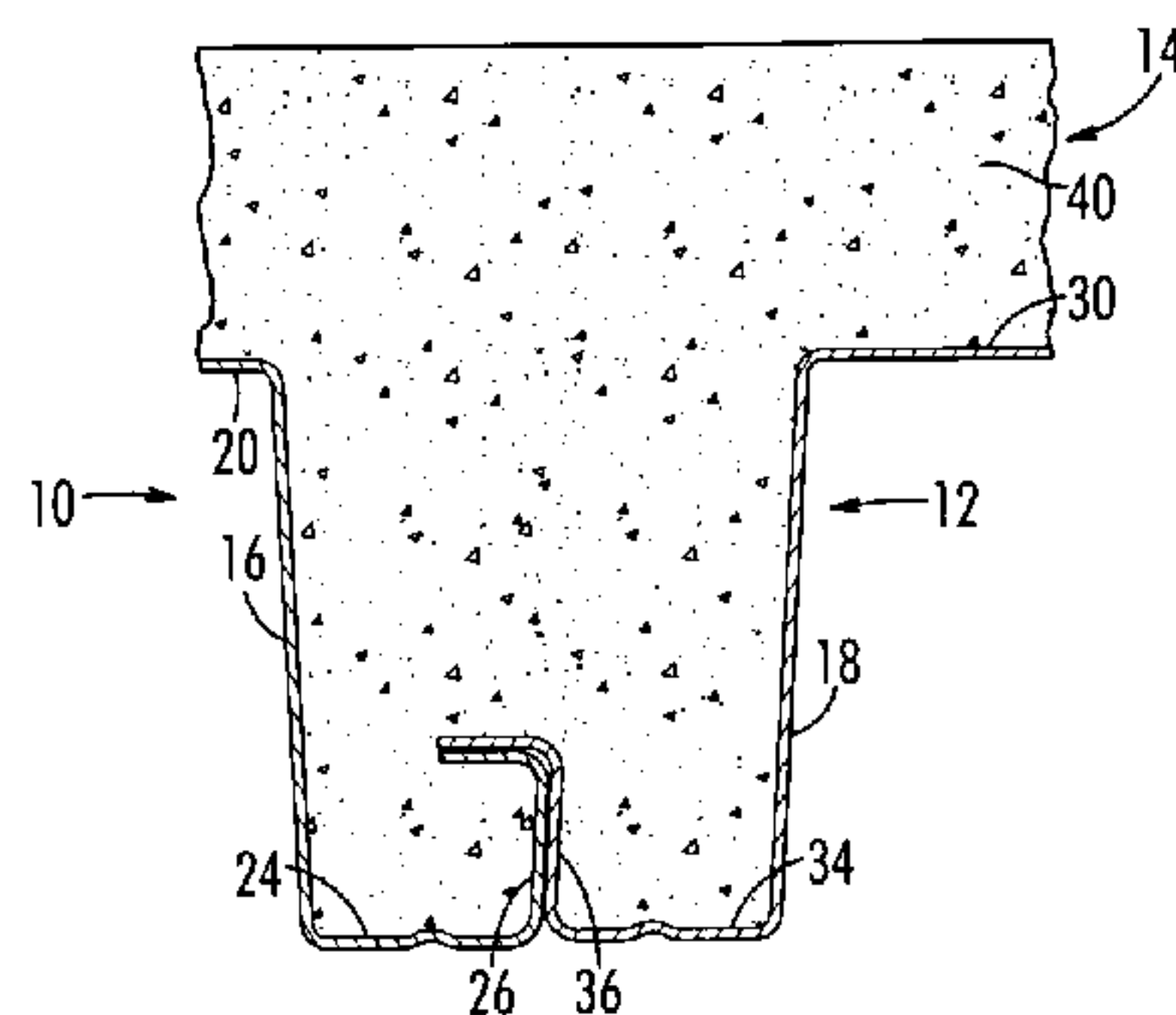

FIG. 1B

(57) Abstract: A composite deck system having a deck component and a concrete component. The deck component of the present invention includes deck sections, each having a longitudinally-extending rib with spaced apart sidewalls connected to a top wall. At the opposing ends of the sidewalls can be included side edges or webs having upturned flanges with an opening or openings along the flanges that are dimensioned to facilitate composite action between the deck sections and the concrete. The system includes a first deck section, as described, adjacent to a second deck section, wherein the side edges of the first and second deck sections are in juxtaposed relation. These deck sections can be combined with concrete to form a composite deck.

WO 2009/051589 A1

**WO 2009/051589 A1**



PT, RO, SE, SI, SK, TR), OAPI (BF, BJ, CF, CG, CI, CM,  
GA, GN, GQ, GW, ML, MR, NE, SN, TD, TG).

**Published:**

— *with international search report*

**Declarations under Rule 4.17:**

- *as to applicant's entitlement to apply for and be granted a patent (Rule 4.17(ii))*
- *of inventorship (Rule 4.17(iv))*

**TITLE****COMPOSITE DECK SYSTEM****BACKGROUND OF THE INVENTION**

[0001] The present invention relates to composite decks.

5 [0002] The use of metal decks or sheets to act compositely with concrete slabs is known. These structures are commonly referred to as "composite decks," and are often used in the construction of floors. Composite decks are more efficient than non-composite decks because they make use of the strength of both the steel and the concrete components, resulting in lighter, more cost-effective floors. 10 Because composite decks are widely used in construction applications, there is a great demand that these components be both structurally sound and economical. Thus, the functionality and durability of composite decks are of utmost significance.

[0003] In order to ensure that a composite deck will function properly and will have a long lifespan, the interaction between the concrete and the metal decks or 15 sheets must remain in tact. The less separation that occurs between the metal sheet and the concrete interface, the more stable and stronger the composite deck will be. Accordingly, the "co-action" or "composite action" between the metal deck and the concrete can determine the overall success of the composite deck.

[0004] Various means have been employed to enhance composite action 20 between metal decks and concrete. For example, embossments along the metal sheets have been used. Altering the dimension and stiffness of the deck profile has also been used. Additionally, the use of steel wires welded to the web of decks has been used to enhance composite action. The gain of composite action produced by these means, however, is often negated by the loss of flexibility in construction 25 design necessitated by these types of devices. Furthermore, composite action between the deck and the concrete of these devices is not ideal and can still be improved.

[0005] Accordingly, there exists a need for a composite deck system that can exhibit improved composite action between the metal deck component and concrete, 30 and that can provide greater overall flexibility in construction applications.

**SUMMARY OF THE INVENTION**

[0006] The following presents a simplified summary of the invention in order to provide a basic understanding of some aspects of the invention. This summary is not an extensive overview of the invention. It is not intended to identify key or critical 35 elements of the invention or to delineate the scope of the invention. Its sole purpose

is to present some concepts of the invention in a simplified form as a prelude to the more detailed description that is presented later.

**[0007]** The present invention includes a composite deck system having a deck component and a concrete component. The deck component of the present invention includes deck sections, each having a longitudinally-extending rib with spaced apart sidewalls connected to a top wall. At the opposing ends of the sidewalls can be included side edges or webs having upturned flanges with an opening or openings along the flanges that are dimensioned to facilitate composite action between the deck sections and the concrete. As used herein, "composite action" refers to the interaction between a deck and concrete. The system includes a first deck section, as described, adjacent to a second deck section, wherein the side edges of the first and second deck sections are in juxtaposed relation. These deck sections can be combined with concrete to form a composite deck.

**[0008]** A feature of the present invention is the use of a composite deck system that employs deck sections having side edges with upturned flanges in juxtaposed relation, whereby the flanges have an opening or openings dimensioned to achieve composite interaction between the decks and poured-in place concrete. In particular, the deck flanges can include a wide variety of openings, such as notches or perforations. These openings can act in concert with the side edges to achieve enhanced composite action between the decks and the concrete. When the concrete component is added to the deck sections, the openings can create both vertical and horizontal locking with the concrete in relation to the orientation of the decks. With improved compatibility between the decks and the concrete comes greater flexibility in the construction applications employing the composite decks. For example, the composite deck system of the present invention can allow for longer and wider deck spans. Moreover, the strength provided by the composite deck system of the present invention can allow for other structural components, such as columns or beams, to be eliminated and/or spaced further apart. This additional flexibility, therefore, can offer different aesthetic environments. Additionally, with fewer structural components needed, the costs and installation times of construction can be reduced.

**[0009]** Another feature of the present invention includes the use of a deck component having side edges with upturned flanges. This feature can further enhance the vertical locking between the deck sections and the concrete. Furthermore, the upturned flanges can act as a pillar, thereby enhancing the load

carrying capacity of the composite deck system. In particular, this feature can provide restraint to the vertical component of the strain differential between the decks and the concrete under the superimposed load condition.

5 [0010] Other features and advantages of the present invention will be apparent to those skilled in the art from a careful reading of the Detailed Disclosure of the Preferred Embodiments presented below and accompanied by the drawings.

#### **BRIEF DESCRIPTION OF THE DRAWINGS**

In the drawings,

10 [0011] FIG. 1A illustrates a plan view of deck sections including a concrete component according to a first embodiment of the composite deck system of the present invention;

[0012] FIG. 1B illustrates a plan view of deck sections in combination with a concrete component according to a first embodiment of the composite deck system of the present invention;

15 [0013] FIG. 2 illustrates an end view of a deck section of a first embodiment of the composite deck system of the present invention;

[0014] FIG. 3A illustrates a perspective view of adjacent deck sections of a first embodiment of the composite deck system of the present invention;

20 [0015] FIG. 3B illustrates an end view of the adjacent deck sections of FIG. 3A of a first embodiment of the composite deck system of the present invention;

[0016] FIG. 4A illustrates a plan view of deck sections including a concrete component according to an alternative embodiment of the composite deck system of the present invention;

25 [0017] FIG. 4B illustrates a plan view of deck sections including a concrete component according to an alternative embodiment of the composite deck system of the present invention;

[0018] FIG. 5 illustrates a top plan view of adjacent deck sections according to a first embodiment of the composite deck system of the present invention;

30 [0019] FIG. 6A illustrates a cross-sectional view of adjacent deck sections taken at line 6A-6A of FIG. 5 of a first embodiment according to a first embodiment of the composite deck system of the present invention;

[0020] FIG. 6B illustrates a cross-sectional view of adjacent deck sections taken at line 6B-6B of FIG. 5 of a first embodiment according to a first embodiment of the composite deck system of the present invention;

[0021] FIG. 7A illustrates a perspective view of adjacent deck sections of an alternative embodiment of the composite deck system of the present invention;

[0022] FIG. 7B illustrates an end view of the adjacent deck sections of FIG. 4A of an alternative embodiment of the composite deck system of the present invention;

[0023] FIG. 8A illustrates a perspective view of adjacent deck sections of an alternative embodiment of the composite deck system of the present invention;

[0024] FIG. 8B illustrates an end view of the adjacent deck sections of FIG. 5A of an alternative embodiment of the composite deck system of the present invention;

[0025] FIG. 9 illustrates a perspective view of adjacent deck sections of an alternative embodiment of the composite deck system of the present invention;

[0026] FIG. 10 illustrates a perspective view of adjacent deck sections of an alternative embodiment of the composite deck system of the present invention;

[0027] FIG. 11 illustrates a perspective view of adjacent deck sections of an alternative embodiment of the composite deck system of the present invention;

[0028] FIG. 12 illustrates an end view of adjacent deck sections of an alternative embodiment of the composite deck system of the present invention;

[0029] FIG. 13 illustrates a perspective view of adjacent deck sections of an alternative embodiment of the composite deck system of the present invention;

[0030] FIG. 14 illustrates a perspective view of adjacent deck sections of an alternative embodiment of the composite deck systems of the present invention.

#### **DETAILED DESCRIPTION OF THE PREFERRED EMBODIMENTS**

[0031] As illustrated in FIGS. 1A-1B, the present invention includes a composite deck system **10** including a deck component **12** and a concrete component **14**. The deck component **12** can include a first deck section **16** and a second deck section **18** that are adjacent along their longitudinal axes. Additional deck sections can be employed depending on the required width of the composite deck system and the dimensions of the deck sections. The decks employed can be made of metal, such as steel. If steel is used, the thickness of the steel will depend on the application of the resulting composite deck. Generally, the first deck section **16** and the second deck section **18** include longitudinally-extending, protruding ribs **50**, as shown in FIG. 2. The illustration of the ribs **50** is made merely for completeness to place the deck sections into context; therefore, the shape of the ribs **50** can vary depending on structural and/or aesthetic preferences. Although

alternative methods can be employed to construct the composite deck system **10** of the present invention, one method includes pouring the concrete in place after aligning and connecting the deck sections **16**, **18** and securing the deck sections **16**, **18** to a structure, such as load bearing element.

5           **[0032]** In a first embodiment, the first deck section **16** includes a first top surface **20** connected to a first side wall **22** and a first side edge **24**, which is in a plane approximately parallel to the plane of the first top surface **20**, and which has a first upturned flange **26** with a first opening **28**. The second deck section **18** is approximately identical to the first deck section **16**, and includes a second top surface **30** connected to a second side wall **32** and a second side edge **34**, which is in a plane approximately parallel to the plane of the second top surface **30**, and which has a second upturned flange **36** with a second opening **38** that is in juxtaposed relation to the first upturned flange **26**. The concrete component includes a concrete layer **40** that is positioned on the first and second deck sections **16**, **18**,  
10           whereby the concrete layer **40** surrounds the deck sections, including the first and second upturned flanges **26**, **36**.

**[0033]** As discussed, a feature of the present invention includes the use of deck sections having side edges with flanges that include an opening or openings. These openings can act in concert with the side edges to achieve enhanced  
20           composite action between the deck sections **16**, **18** and concrete. Using the first embodiment as an example, when the concrete component **14** is added to the deck sections **16**, **18**, the openings **28**, **38** can create both vertical and horizontal locking with the concrete **40** in relation to the orientation of the decks. In particular, the flanges can distribute the strain interaction in a regular and nearly continuous  
25           manner thereby minimizing the end slip phenomenon that is common to many composite deck systems. Further, when the flanges are confined within the concrete **40** thereby stiffening the deck at the point of the interaction, this feature enables the deck to resist the strain to near bearing type capacity.

**[0034]** With improved compatibility between the decks and the concrete **40**  
30           comes greater flexibility in the construction applications employing the composite deck system **10**. For example, the composite deck system **10** of the present invention can allow for longer and wider deck spans. Moreover, the strength provided by the composite deck system **10** of the present invention can allow for other structural components, such as columns and beams, to be eliminated and/or  
35           spaced further apart. This additional flexibility, therefore, can offer different aesthetic

environments. Additionally, with fewer structural components needed, the costs and installation times of construction can be reduced.

5 [0035] Another feature of the present invention includes the use of a deck component having side edges with upturned flanges. This feature can further enhance the vertical locking between the deck sections and the concrete. Furthermore, the upturned flanges can act as a pillar, thereby enhancing the load carrying capacity of the composite deck system 10. In particular, this feature can provide restraint to the vertical component of the strain differential between the decks and the concrete 40 under the superimposed load condition.

10 [0036] The particular shapes and dimensions of the first and second upturned flanges 26, 36, as well as the openings along the flanges can vary. In the first embodiment, shown in FIGS. 3A-3B, the first and second upturned flanges 26, 36, can be approximately perpendicular to the first and second side edges 24, 34 of the deck sections 16, 18. As further illustrated, the flanges 26, 36 can generally have an inverted L-shape with first and second base member 29, 39 connected to a first and second protruding rim 27, 37, respectively, and can extend longitudinally along the length of the deck sections 16, 18. The plane of the first and second rims 27, 37 is approximately parallel to the plane of the first and second side edges 24, 34. Additionally, the angle A between the first flange 26 and the first side edge 24 is about 90°, and the angle B between the second flange 36 and the second side edge is about 90°. The second flange 36 can be dimensioned to overlap the first flange 26 so that the flanges are juxtaposed. When the composite deck is formed, the deck sections 16, 18 can be aligned so that the first and second flanges 26, 36 are engaged or nested.

25 [0037] Depending on the application of the composite deck system 10, each deck section can include a flange as presently described along one side edge or along both side edges. In the case that the deck section is being used as a central section and will include adjacent deck sections on either side, the deck section can include a flange on both of its side edges, as shown in FIG. 2. Further, if the flanges employ the shape of the first embodiment, the deck section will have a nesting flange 51 along one side edge, and an overlapping flange 53 along the opposing side edge.

30 [0038] In addition to the L-shape, the first and second flanges 26, 36 can also include an opening. As shown, each of the flanges includes an opening 28, 38. In particular, the opening can be a notch that is roughly rectangular in shape and that is included along the edge of the flange rims 27, 37. If both the first and second

35

flanges **26, 36** include an opening, the openings **28, 38** can be approximately the same size and be in approximately the same location, whereby when the first flange **26** and the second flange **36** are aligned, the openings **28, 38** are matched. As used herein, "matched openings" refers to openings that are of about the same shape and dimension and are positioned in about the same location along juxtaposed first and second flanges. Alternatively, there can be one opening along one or both of the first and second flange rims **27, 37**, as well as one or both of the first and second base members **29, 39**, or there can be a plurality of openings along one or both of the first and second flanges **26, 36**, as well as one or both of the first and second base members **29, 39**.

**[0039]** Alternative embodiments are also contemplated by the present invention. These embodiments are shown in FIGS. 4A-14. In the first alternative embodiment, shown in combination with a concrete component in FIGS. 4A-4B, and shown in detail in FIGS. 5A-6B, the first and second upturned flanges **26, 36**, can be approximately perpendicular to the first and second side edges **24, 34** of the deck sections **16, 18**. As further illustrated, the flanges **26, 36** can generally have an inverted L-shape with first and second base member **29', 39'** connected to a first and second protruding rim **27', 37'**, respectively, and can extend longitudinally along the length of the deck sections **16, 18**. In particular, the first flange **26** can include a first and second cut, **28'**, and the second flange **36** can include a third and fourth cut **38'**, respectively. Between the cuts **28', 38'**, the flanges **26, 36** include a first fold **21** and a second fold **23**, respectively, along the longitudinal edges. As shown, second fold **23** covers the first fold **21**, so that the folds are nested. The plane of the first and second rims **27', 37'** is approximately parallel to the plane of the first and second side edges **24, 34**. Additionally, the angle A between the first flange **26** and the first side edge **24** is about 90°, and the angle B between the second flange **36** and the second side edge is about 90°. The second flange **36** can be dimensioned to overlap the first flange **26** so that the flanges are juxtaposed. When the composite deck is formed, the deck sections **16, 18** can be aligned so that the first and second flanges **26, 36** are engaged or nested.

**[0040]** In another alternative embodiment shown in FIGS. 7A-7B, the first and second flanges **26, 36** are shaped similarly to the flanges of the first embodiment, except that the first and second flanges **26, 36** are at different angles with relation to the side edges **24, 34**. In particular, angle A between the first flange **26** and the first side edge **24** is greater than about 90°, and the angle B between the second flange

**36** and the second side edge **34** is less than about  $90^\circ$ . Additionally, because the angles of the flanges are distinct, the planes of the first and second rims **27**, **37** are no longer parallel with the plane of the first and second side edges **24**, **34**, and are instead an angle to the planes of the first and second side edges **24**, **34**. Alternatively, there can be one opening along one or both of the first and second flange rims **27**, **37**, as well as one or both of the first and second base members **29**, **39**, or there can be a plurality of openings along one or both of the first and second flanges **26**, **36**, as well as one or both of the first and second base members **29**, **39**.

**[0041]** FIGS. 8A-8B illustrate another alternative embodiment. As shown, the flanges **26**, **36** of this embodiment are similar to the embodiment of FIGS. 7A-7B, except that the openings **28**, **38** are not notches along the edges of the flange rims **27**, **37**, but rather are openings within the flange rims **27**, **37** that can be circular in shape. Again, angle A between the first flange **26** and the first side edge **24** is greater than about  $90^\circ$ , and the angle B between the second flange **36** and the second side edge is less than about  $90^\circ$ . Alternatively, there can be one opening along one or both of the first and second flange rims **27**, **37**, as well as one or both of the first and second base members **29**, **39**, or there can be a plurality of openings along one or both of the first and second flanges **26**, **36**, as well as one or both of the first and second base members **29**, **39**.

**[0042]** Yet another alternative embodiment is illustrated in FIG. 9. As shown, the flanges **26**, **36** are similar to the embodiment described in FIGS. 8A-8B, except the shape of the openings **28**, **38** can be rectangular. Alternatively, there can be one opening along one or both of the first and second flange rims **27**, **37**, as well as one or both of the first and second base members **29**, **39**, or there can be a plurality of openings along one or both of the first and second flanges **26**, **36**, as well as one or both of the first and second base members **29**, **39**.

**[0043]** FIG. 10 illustrates an alternative embodiment that is distinct from the embodiment previously described in that the flanges **26**, **36** do not include a first and second flap **27**, **37** along their respective top edges. Accordingly, there is no overlap of the second flange **34** onto the first flange **24**, and each flange is generally upturned at about  $90^\circ$ , as shown in FIG. 12. Moreover, the openings **28**, **38** can be included along what were previously referred to as base members **29**, **39**. In particular, the openings can be rectangular shaped. Alternatively, there can be one opening along one or both of the first and second base members **29**, **39**, or there can

be a plurality of openings along one or both of the first and second base members **29, 39**.

**[0044]** FIGS. 11 and 13 illustrate alternative embodiments that are similar to that of FIG. 10. In particular, the flanges **26, 36** shown in FIG. 11 are similar to those described and shown in FIG. 10, except the openings **28, 38** are notches along the  
5 respective top, longitudinal edges of the flanges **26, 36**. Furthermore, this embodiment shows that the positioning of the openings **28** of the first flange **26** need not match the openings **38** of the second flange **36**. As shown in FIG. 11, opening **38** is eclipsed by flange **26**. FIG. 13 illustrates flanges **26, 36** similar to those  
10 described and shown in FIG. 10, except the openings **28, 38** are circular in shape.

**[0045]** Although particular shapes and positions have been described and shown with respect to the openings **28, 38**, any geometric shape can be employed along any area of the flanges **26, 36**. Furthermore, the frequency of openings along the flanges can also be varied. For example, the flanges **26, 36** can be perforated  
15 throughout so as to provide a polka-dot type pattern **70**, as shown in FIG. 11. Additionally, it should be understood that the deck section shown in FIG. 2 can include any of the alternative flange embodiment as described, and does not necessarily need to include a nesting flange and an overlapping flange.

20

## WHAT IS CLAIMED IS:

1. A composite deck system, comprising:
  - a first deck section having a first side wall connected to a first top surface, said first side wall including a first side edge having a first upturned flange, wherein said first upturned flange includes a first opening;
  - a second deck section adjacent to said first deck section having a second sidewall connected to a second top surface, said second side wall including a second side edge with a second upturned flange, wherein said second upturned flange is adjacent to said first upturned flange, and wherein said second upturned flange includes a second opening; and
  - a concrete layer positioned on said first top surface and said second top surface and surrounding said first upturned flange and said second upturned flange, where said first and said second openings allow said concrete layer to flow between said first deck section and said second deck section through said first and said second openings so that, upon curing, said concrete layer acts in concert with said first and said second side edges to lock said first and said second deck sections together vertically and horizontally.
2. The composite deck system as recited in claim 1, wherein said first opening and said second opening are circular.
3. The composite deck system as recited in claim 1, wherein said first opening and said second opening are rectangular.
4. The composite deck system as recited in claim 1, wherein said first opening and said second opening are formed in a geometrical shape.

5. The composite deck as recited in claim 1, wherein said first upturned flange and said second upturned flange are perforated.

6. The composite deck system as recited in claim 1, wherein said first upturned flange is a nesting flange, and wherein said second upturned flange is an overlapping flange.

7. The composite deck system as recited in claim 1, wherein said first upturned flange includes a first base member connected to a first rim, and wherein said second upturned flange includes a second base member connected to a second rim.

8. The composite deck system as recited in claim 7, wherein the plane of said first rim and the plane of said second rim are each about parallel with the plane of said first side edge and the plane of said second side edge, respectively, wherein an angle A, defined between said first base member and said first side edge is about  $90^\circ$ , and wherein an angle B, defined between said second base member and said second side edge is about  $90^\circ$ .

9. The composite deck system as recited in claim 7, wherein the plane of said first rim and the plane of said second rim are each at an angle with the plane of said first side edge and the plane of said second side edge, wherein an angle A, defined between said first base member and said first side edge is greater than about  $90^\circ$ , and wherein an angle B, defined between said second base member and said second side edge is less than about  $90^\circ$ .

10. A composite deck system having a deck component and a concrete component, said deck component comprising:

a first deck section having a first side wall connected to a first top surface, said first side wall including a first side edge having a first upturned flange, wherein said first upturned flange includes a first opening; and

a second deck section adjacent to said first deck section having a second sidewall connected to a second top surface, said second side wall including a second side edge with a second upturned flange, wherein said second upturned flange is adjacent to said first upturned flange, and wherein said second upturned flange includes a second opening, said first and said second openings being left open to allow a concrete layer, when said concrete layer is applied to said deck component, to flow between said first deck section and said second deck section through said first and said second openings so that, upon curing, said concrete layer acts in concert with said first and said second side edges to lock said first and said second deck sections together vertically and horizontally.

11. The composite deck system as recited in claim 10, wherein said first opening and said second opening are circular.

12. The composite deck system as recited in claim 10, wherein said first opening and said second opening are rectangular.

13. The composite deck system as recited in claim 10, wherein said first opening and said second opening are formed in a geometrical shape.

14. The composite deck system as recited in claim 10, wherein said first upturned flange and said second upturned flange are perforated.

15. The composite deck system as recited in claim 10, wherein said first upturned flange is a nesting flange, and wherein said second upturned flange is an overlapping flange.

16. The composite deck system as recited in claim 15, wherein said first upturned flange includes a first base member connected to a first rim, and wherein said second upturned flange includes a second base member connected to a second rim.

17. The composite deck system as recited in claim 10, wherein the plane of said first rim and the plane of said second rim are each about parallel with the plane of said first side edge and the plane of said second side edge, respectively, wherein an angle A, defined between said first base member and said first side edge is about  $90^\circ$ , and wherein an angle B, defined between said second base member and said second side edge is about  $90^\circ$ .

18. The composite deck system as recited in claim 10, wherein the plane of said first rim and the plane of said second rim are each at an angle with the plane of said first side edge and the plane of said second side edge, respectively, wherein an angle A, defined between said first base member and said first side edge is greater than about  $90^\circ$ , and wherein an angle B, defined between said second base member and said second side edge is less than about  $90^\circ$ .

19. A composite deck system, comprising:

a first deck section having a first side wall connected to a first top surface, said first side wall including a first side edge having a first upturned flange, wherein said first upturned flange includes a first base that is adjacent to said first side edge, and wherein said first base includes a first opening; and

a second deck section adjacent to said first deck section having a second sidewall connected to a second top surface, said second side wall including a second side edge with a second upturned flange, wherein said second upturned flange is adjacent to said first upturned flange, and wherein said second upturned flange includes a second base that is about perpendicular to said second side edge, and wherein said second base includes a second opening, said first and said second openings remaining open to provide communication between said first and said second deck sections so that, when a concrete layer is applied to said deck component, said concrete layer will extend from said first and said second deck sections through said first and said second openings, and, upon curing, act in concert with said first and said second side edges to lock said first and said second deck sections together both vertically and horizontally.

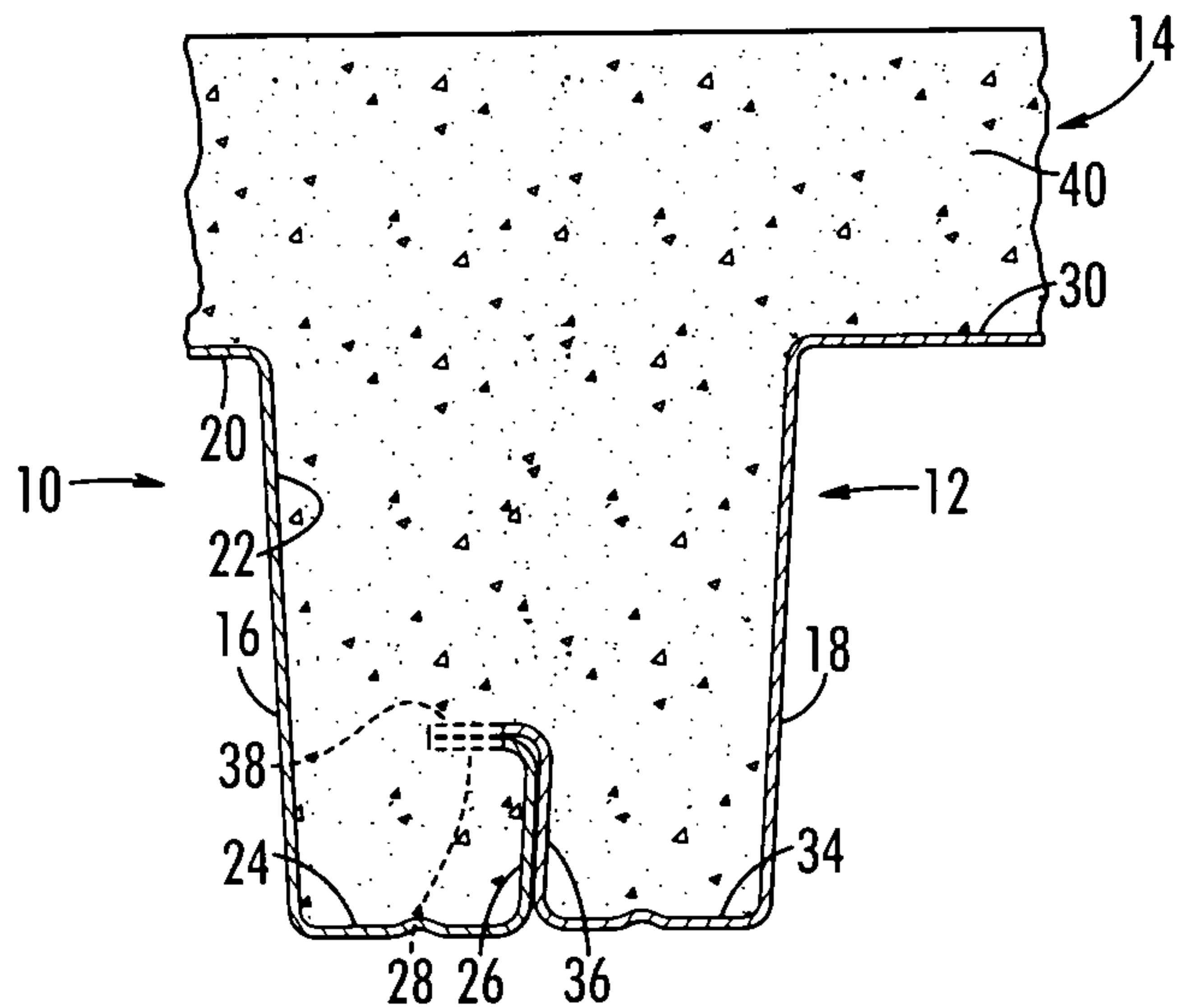

FIG. 1A

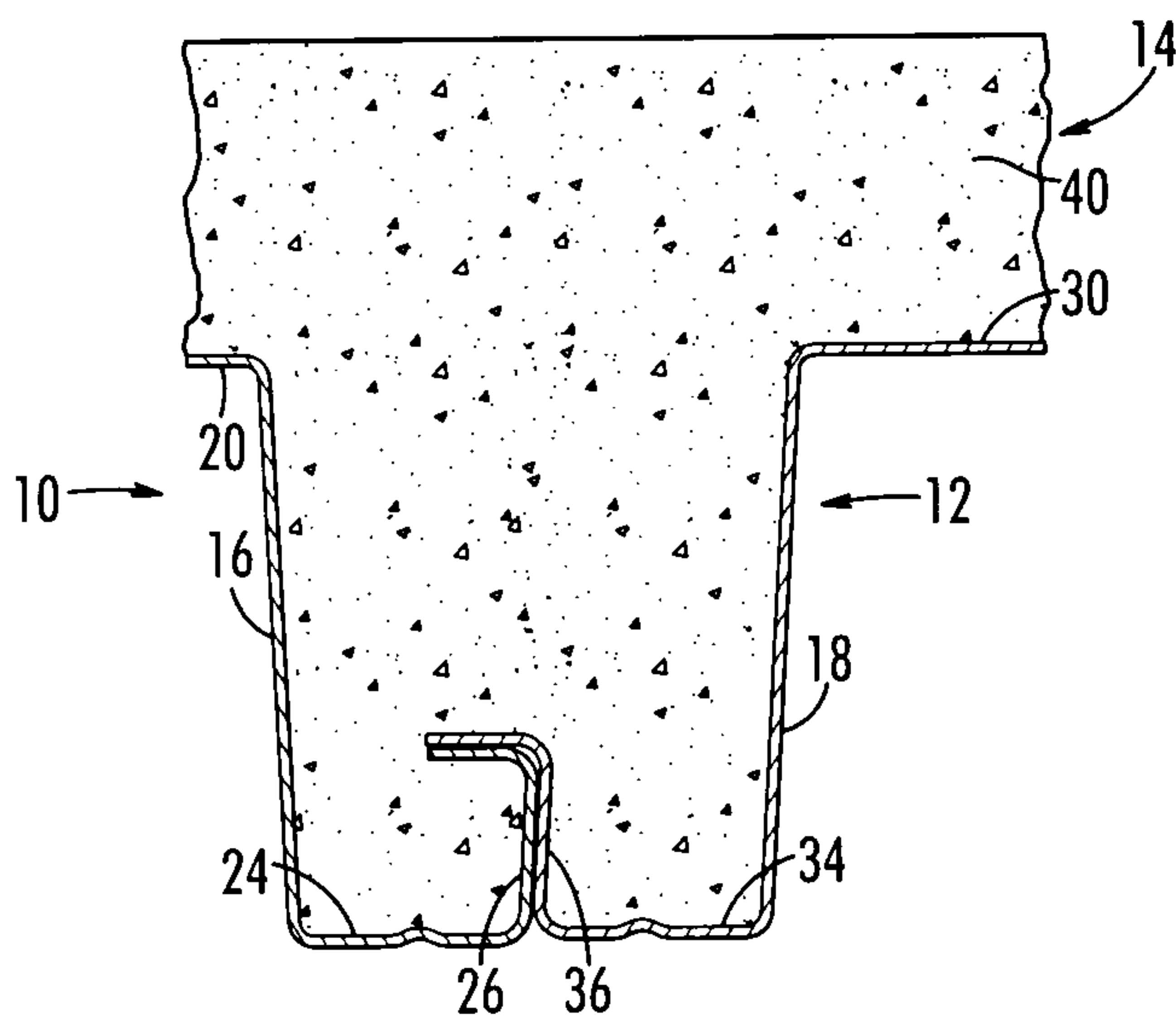

FIG. 1B

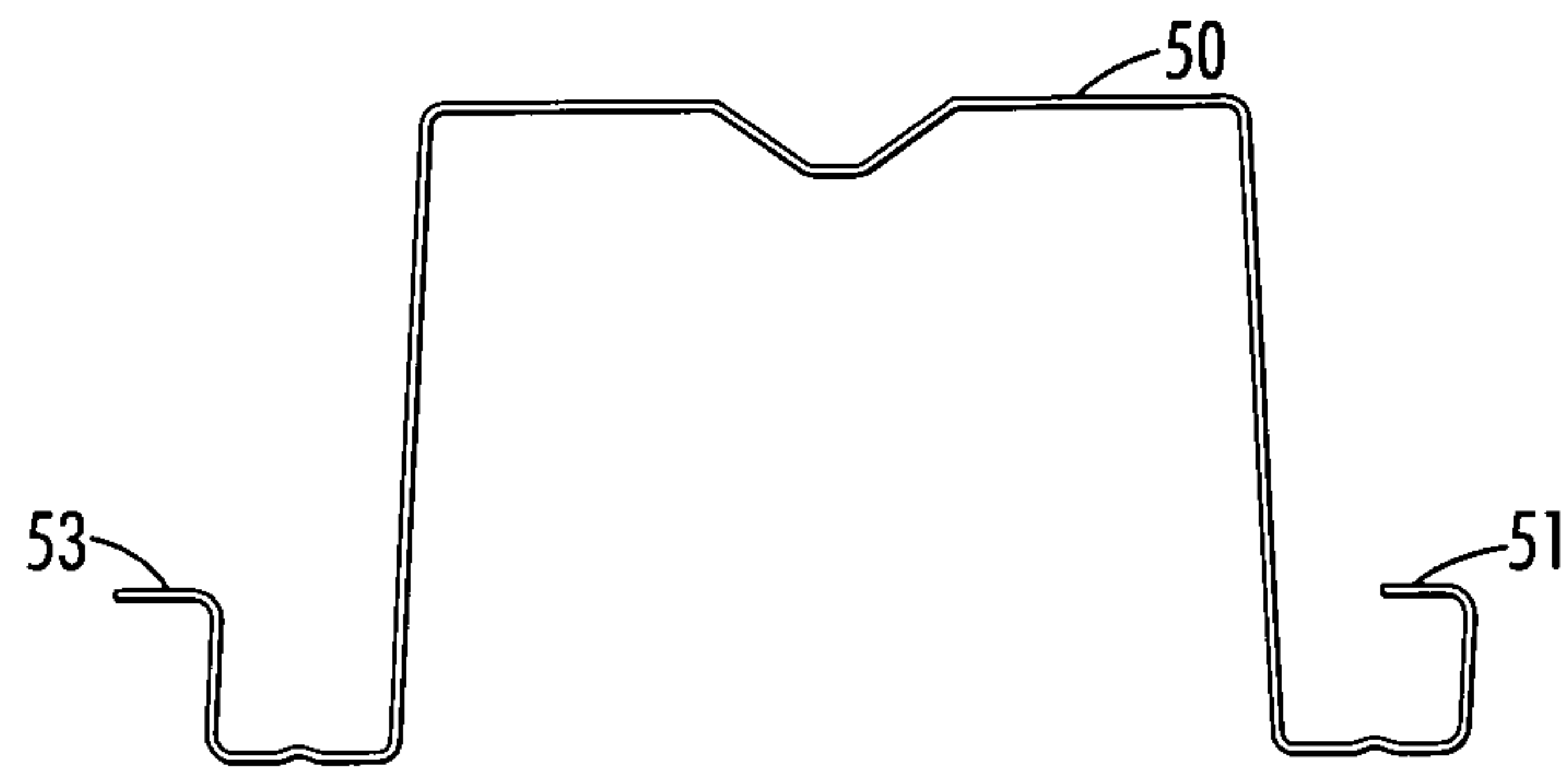

FIG. 2

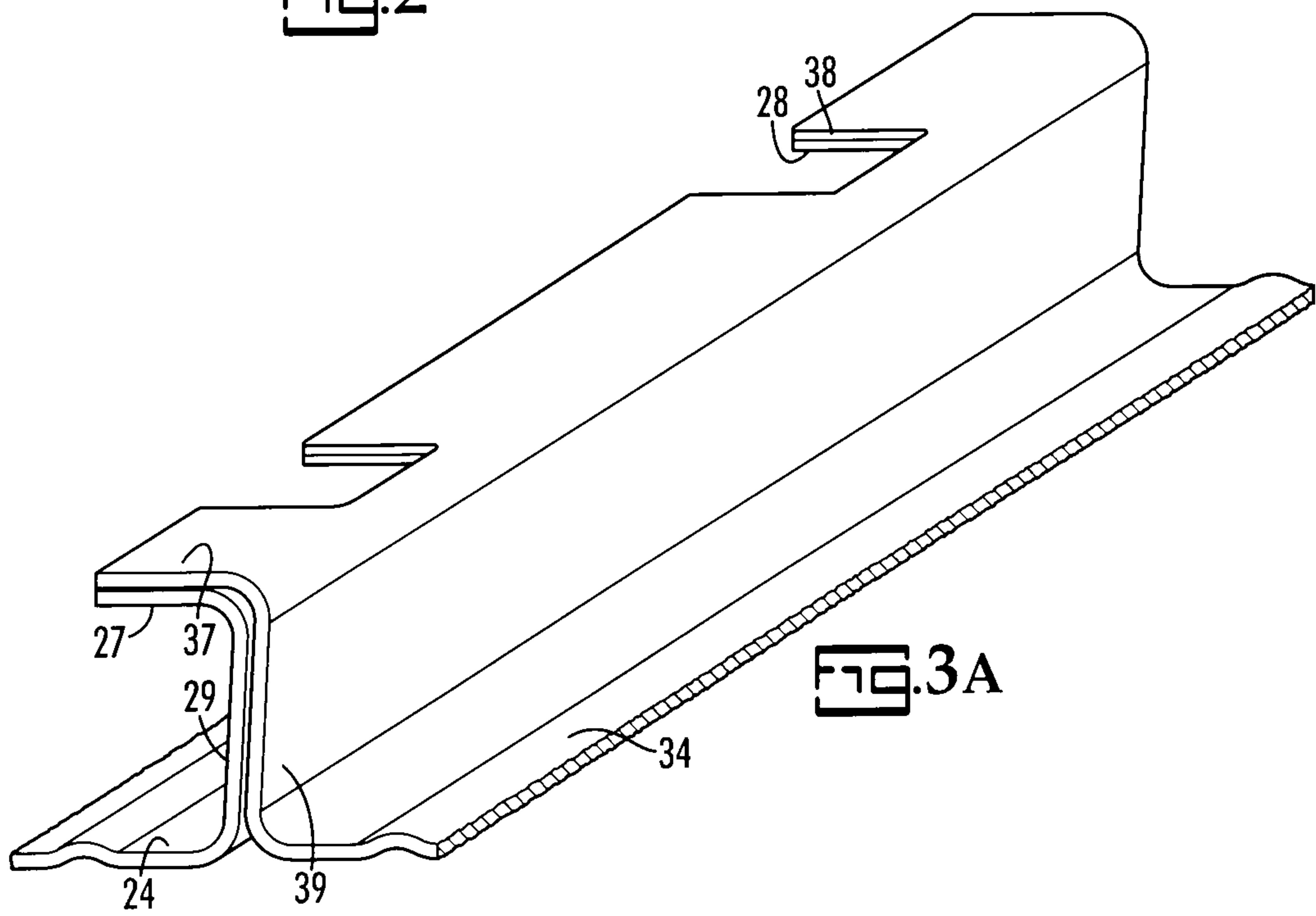

FIG. 3A

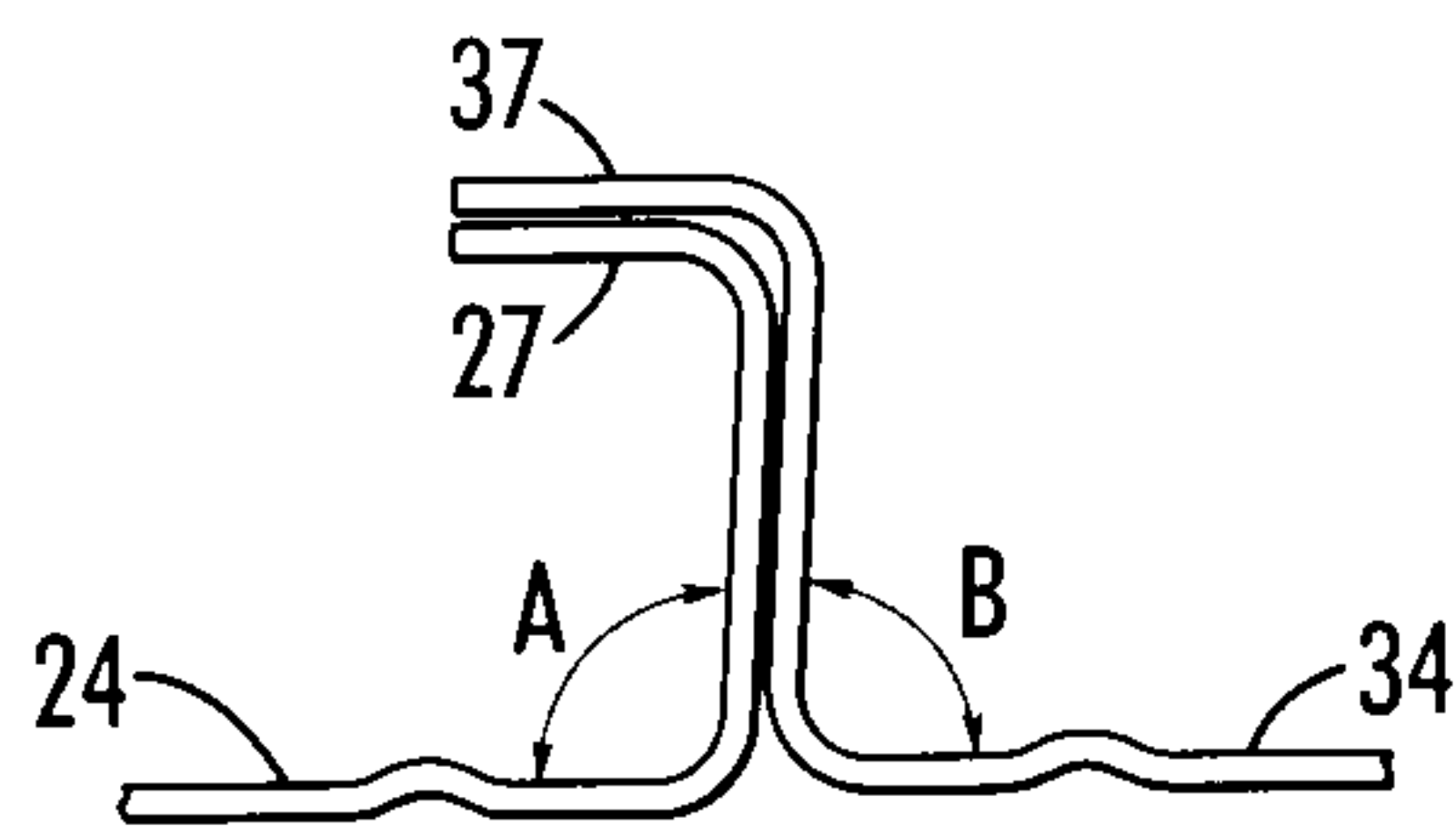

FIG. 3B

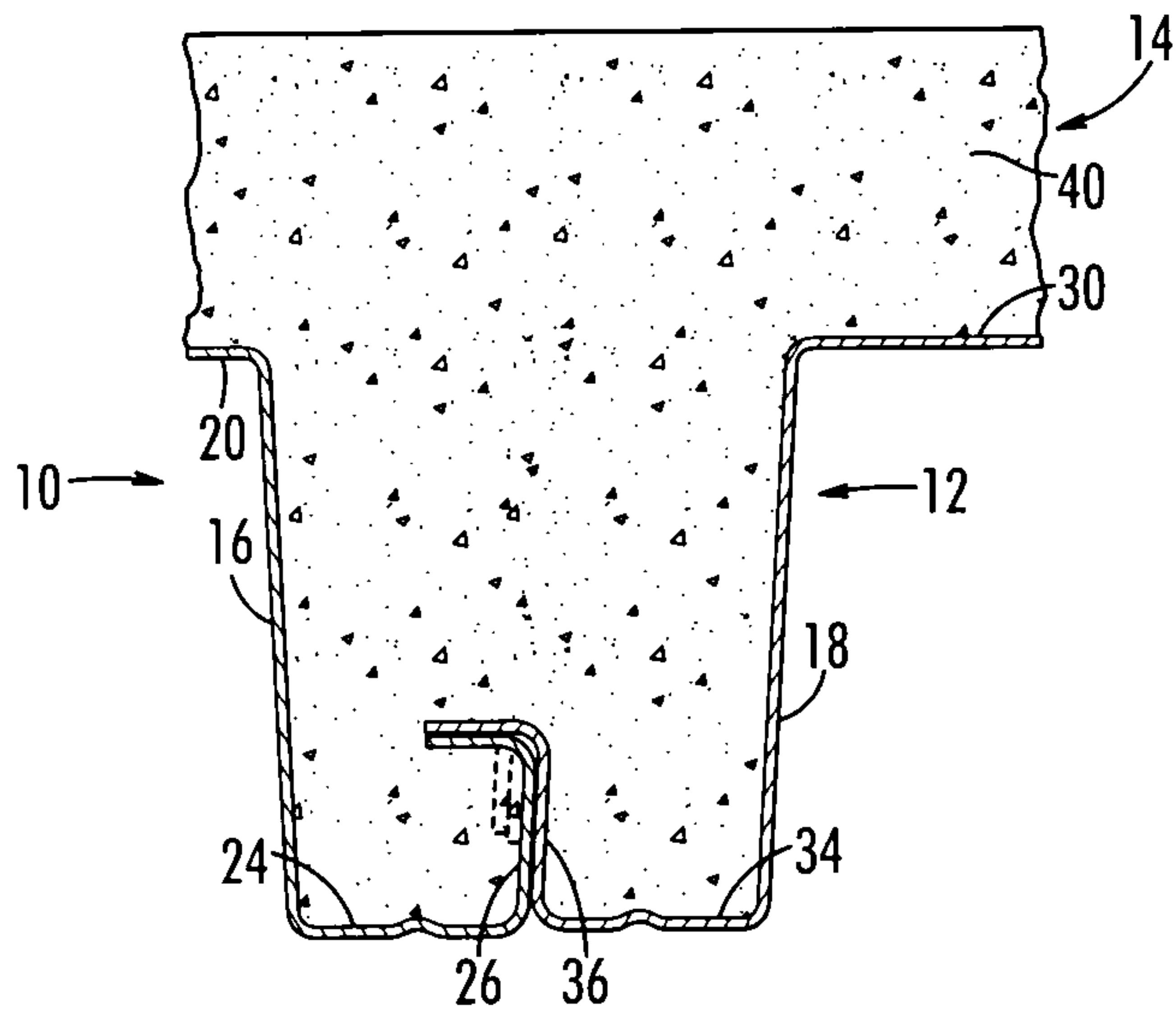

FIG. 4A

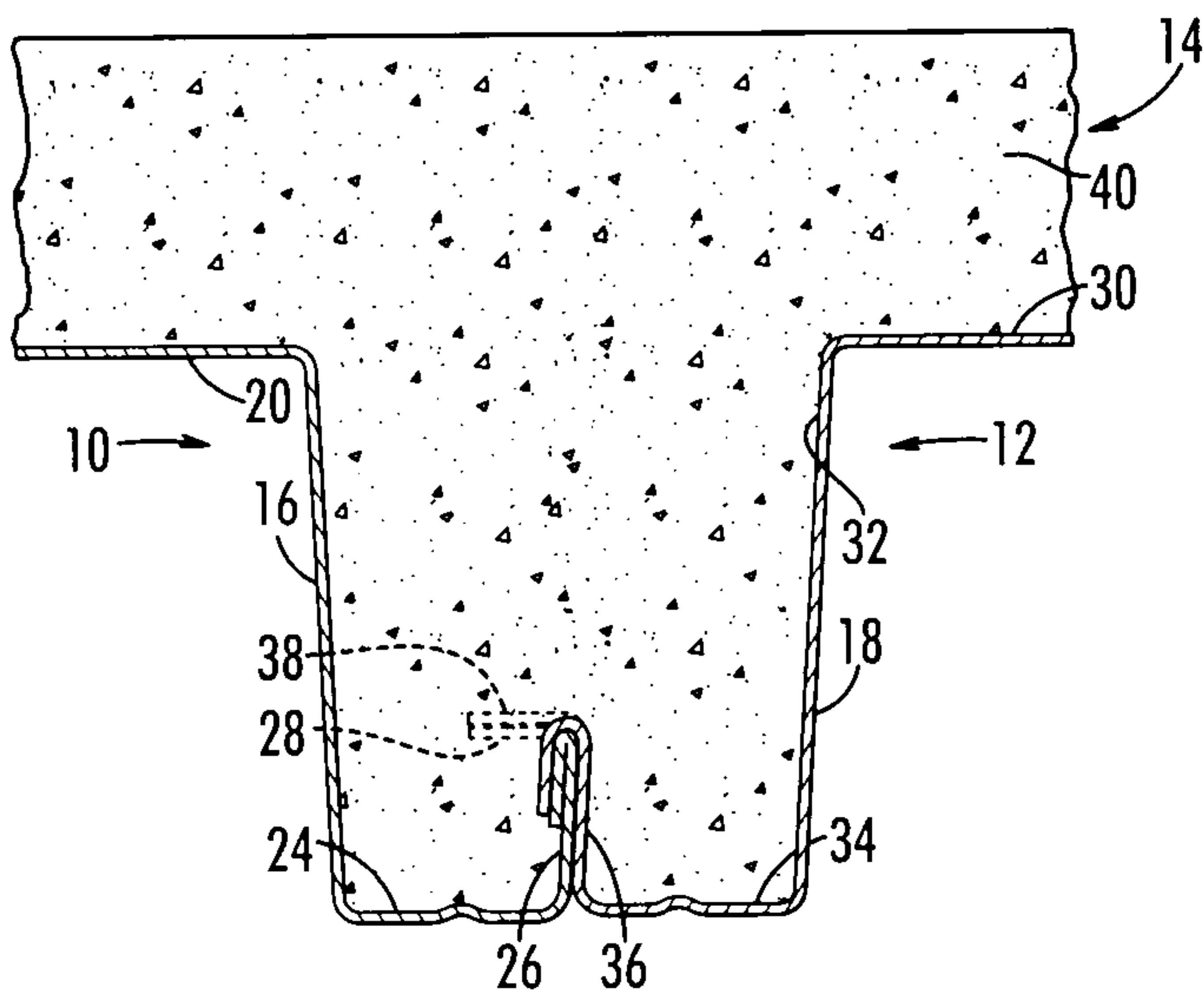
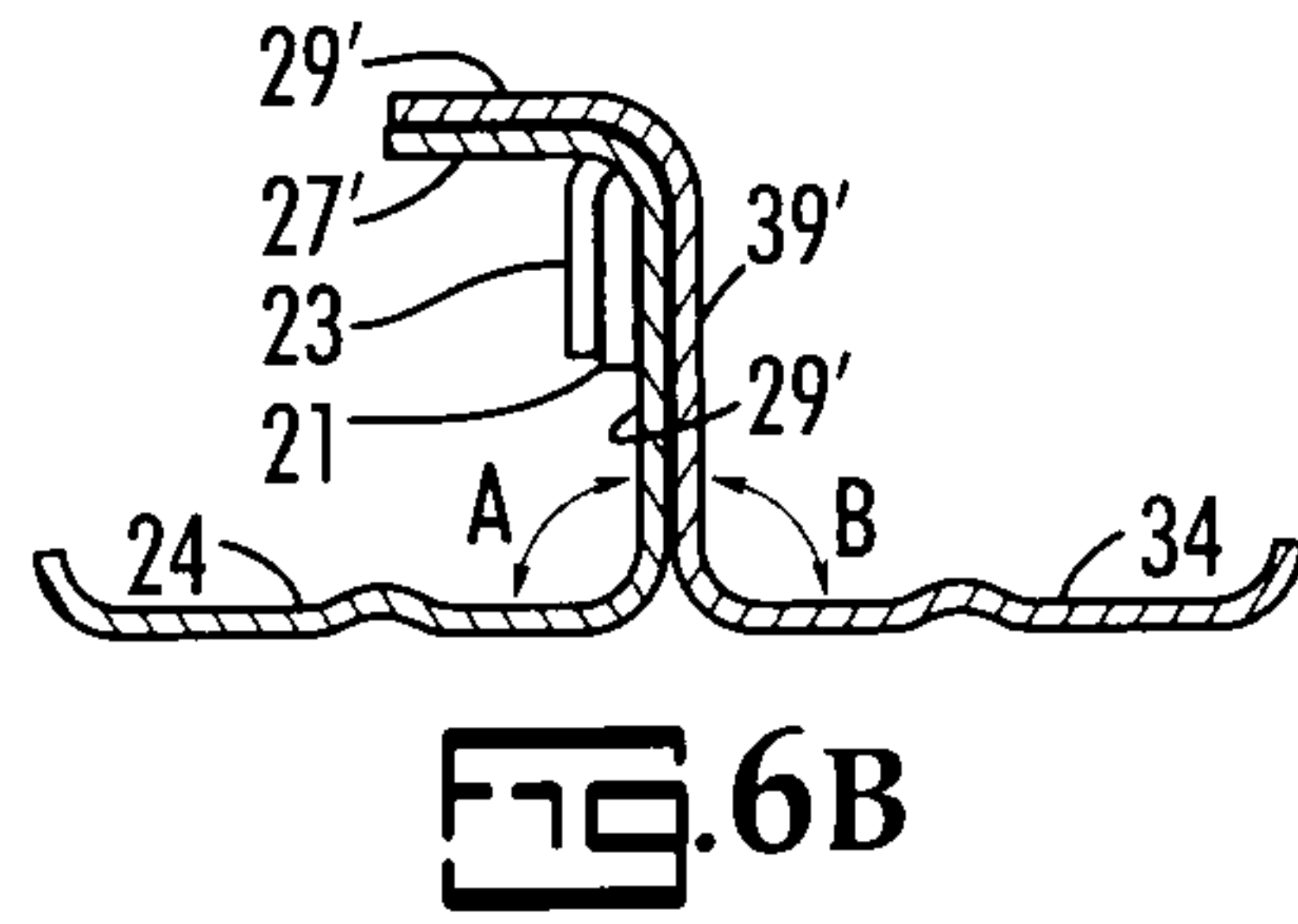
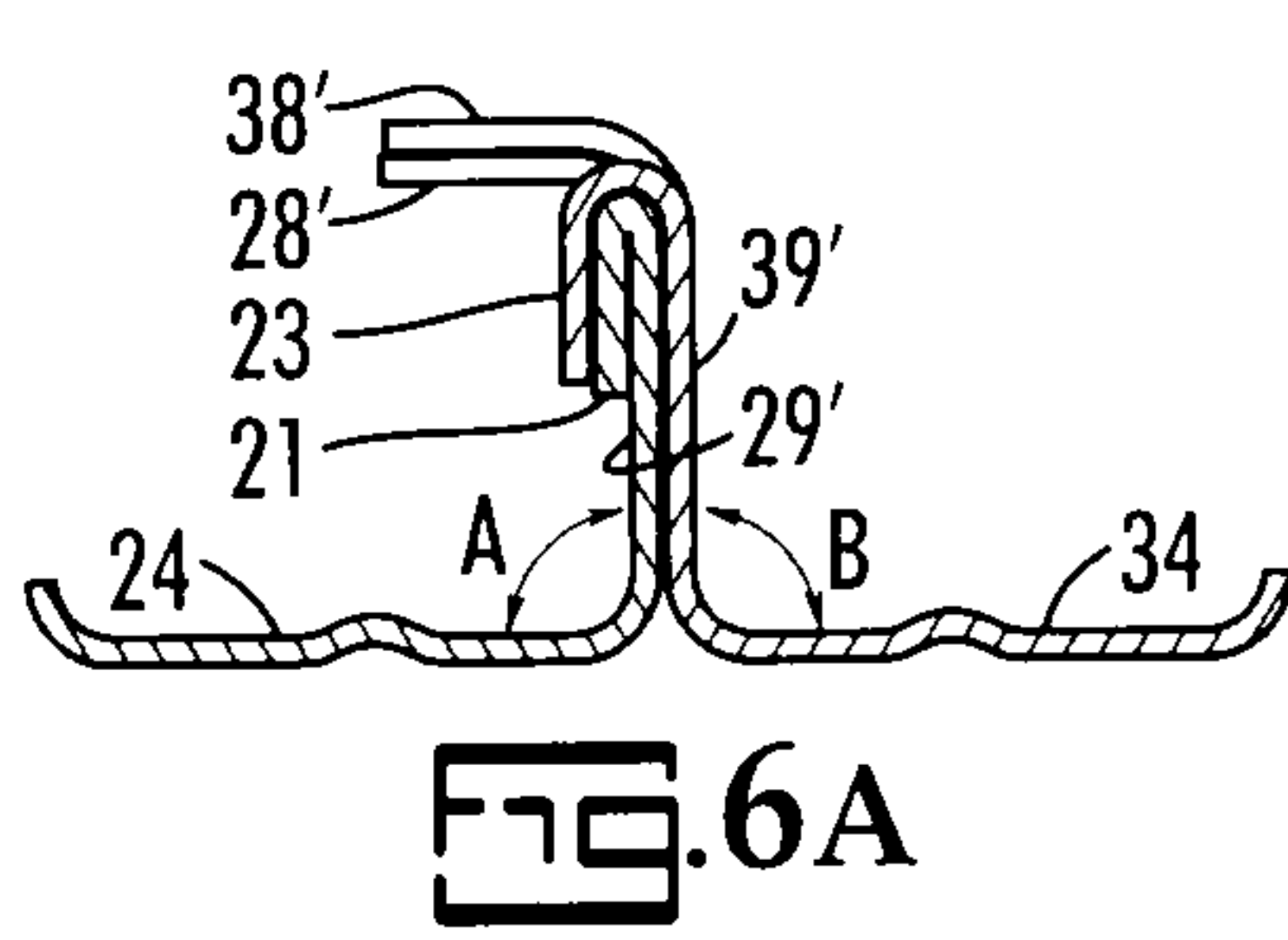
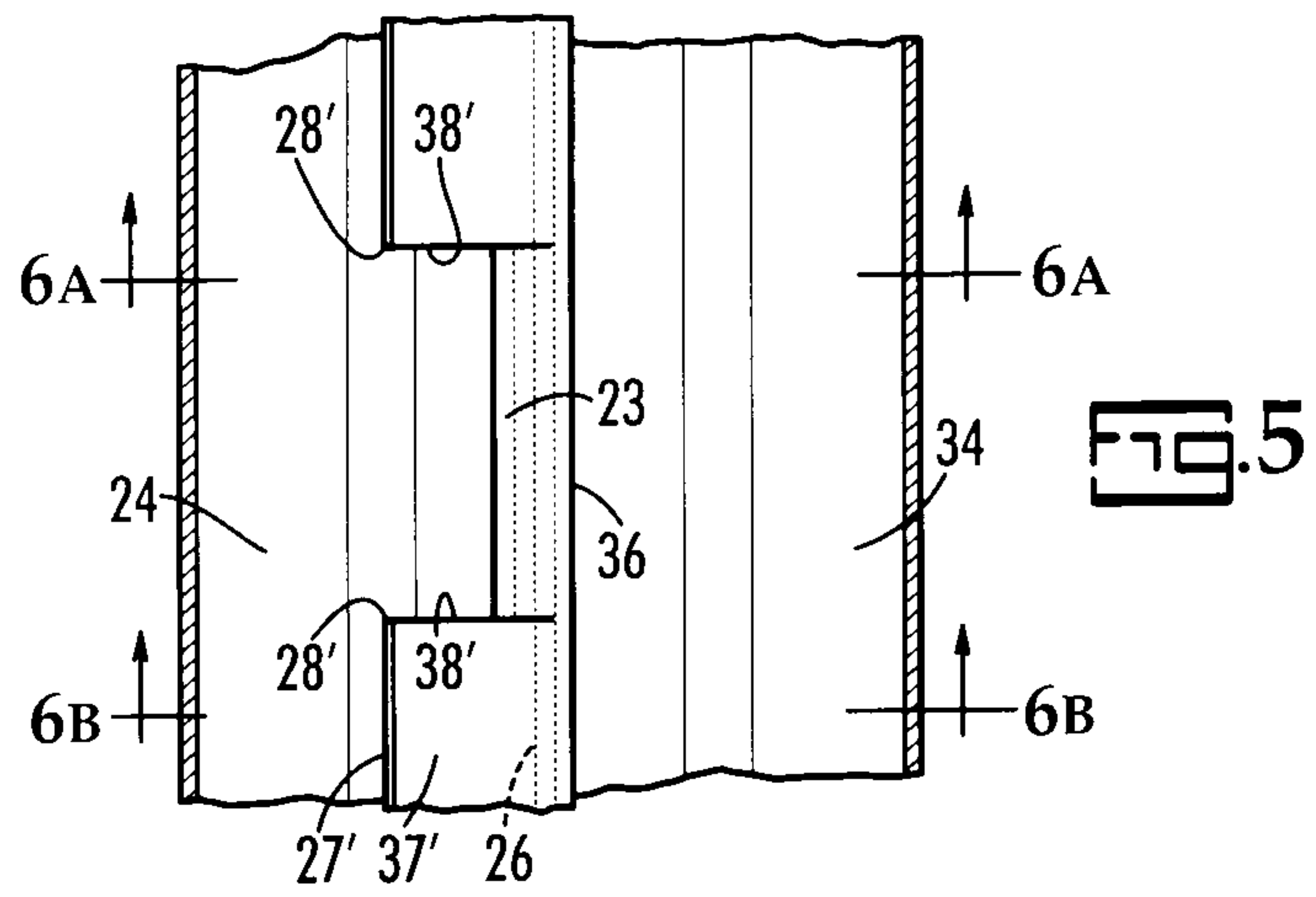

FIG. 4B



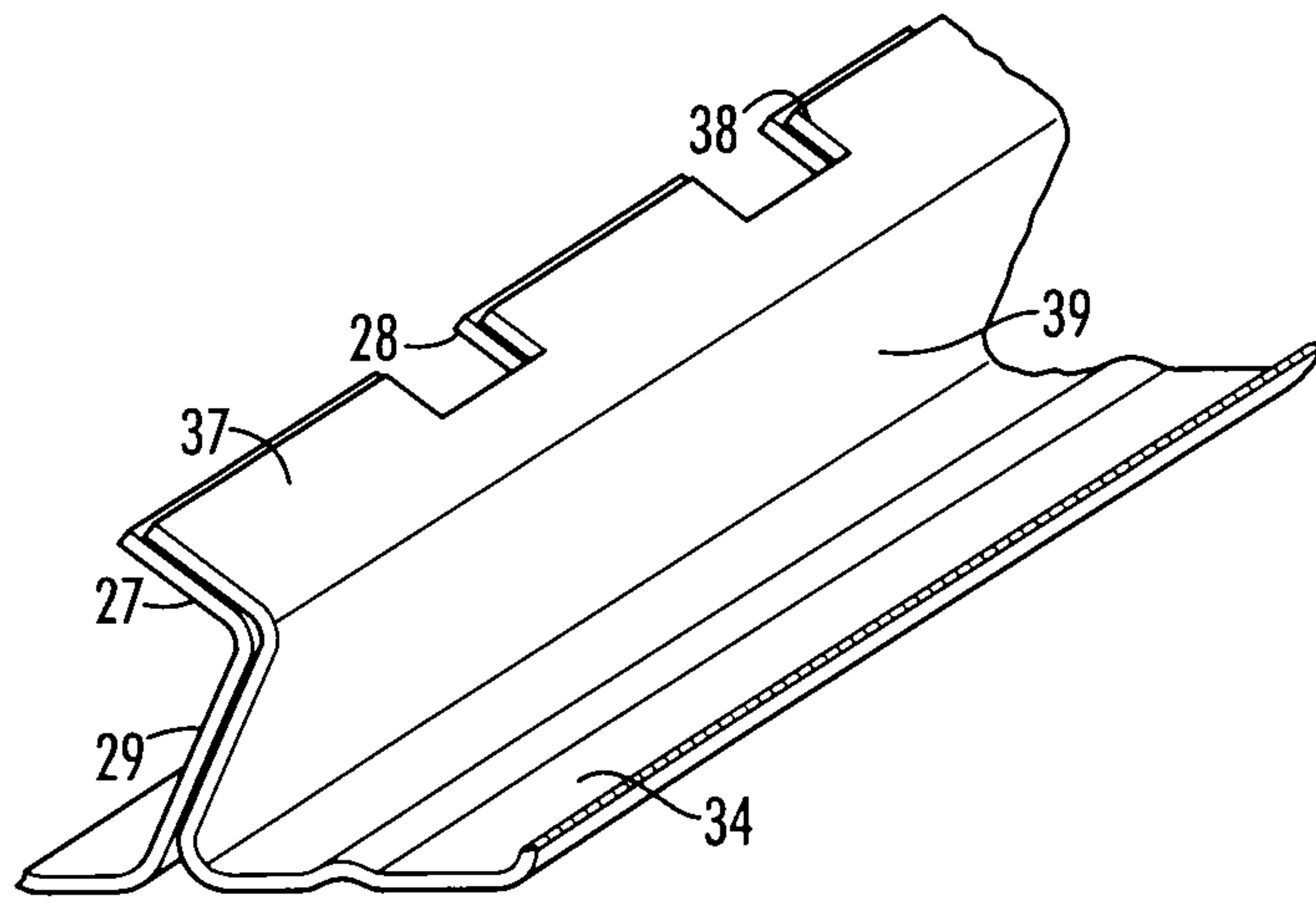

FIG. 7A

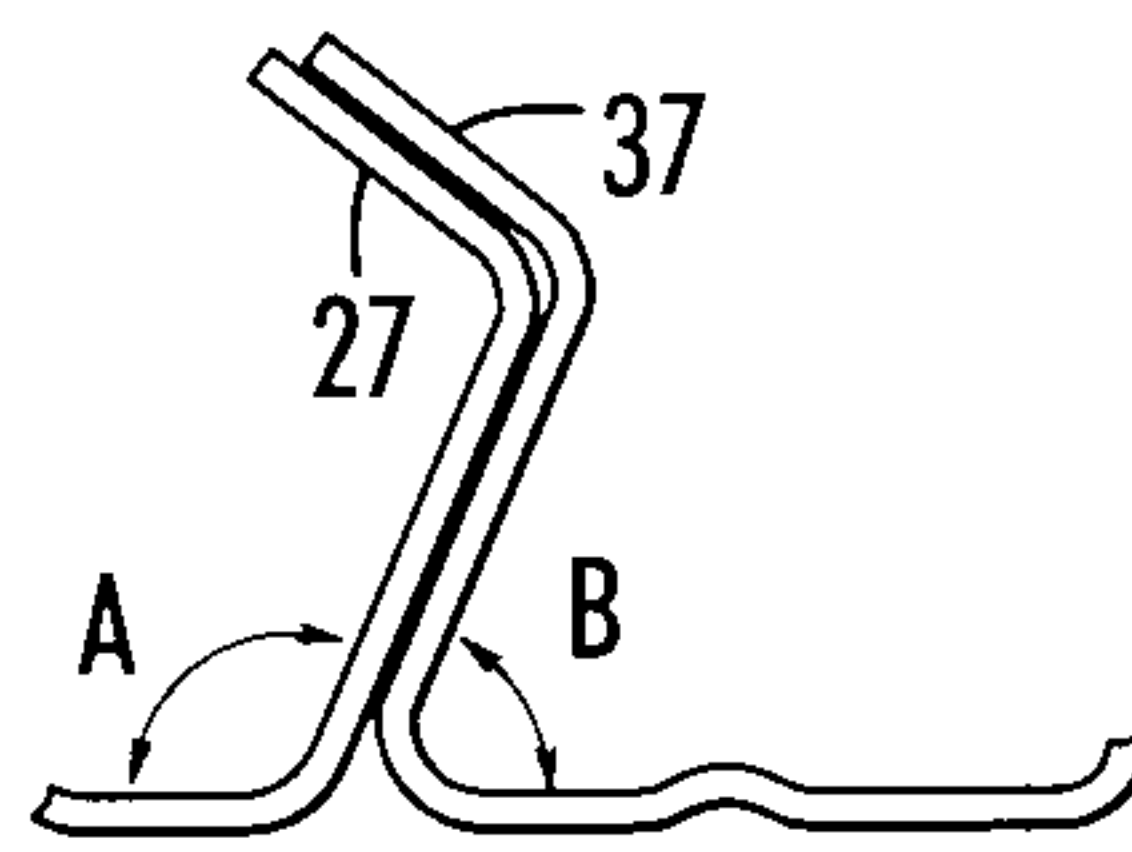
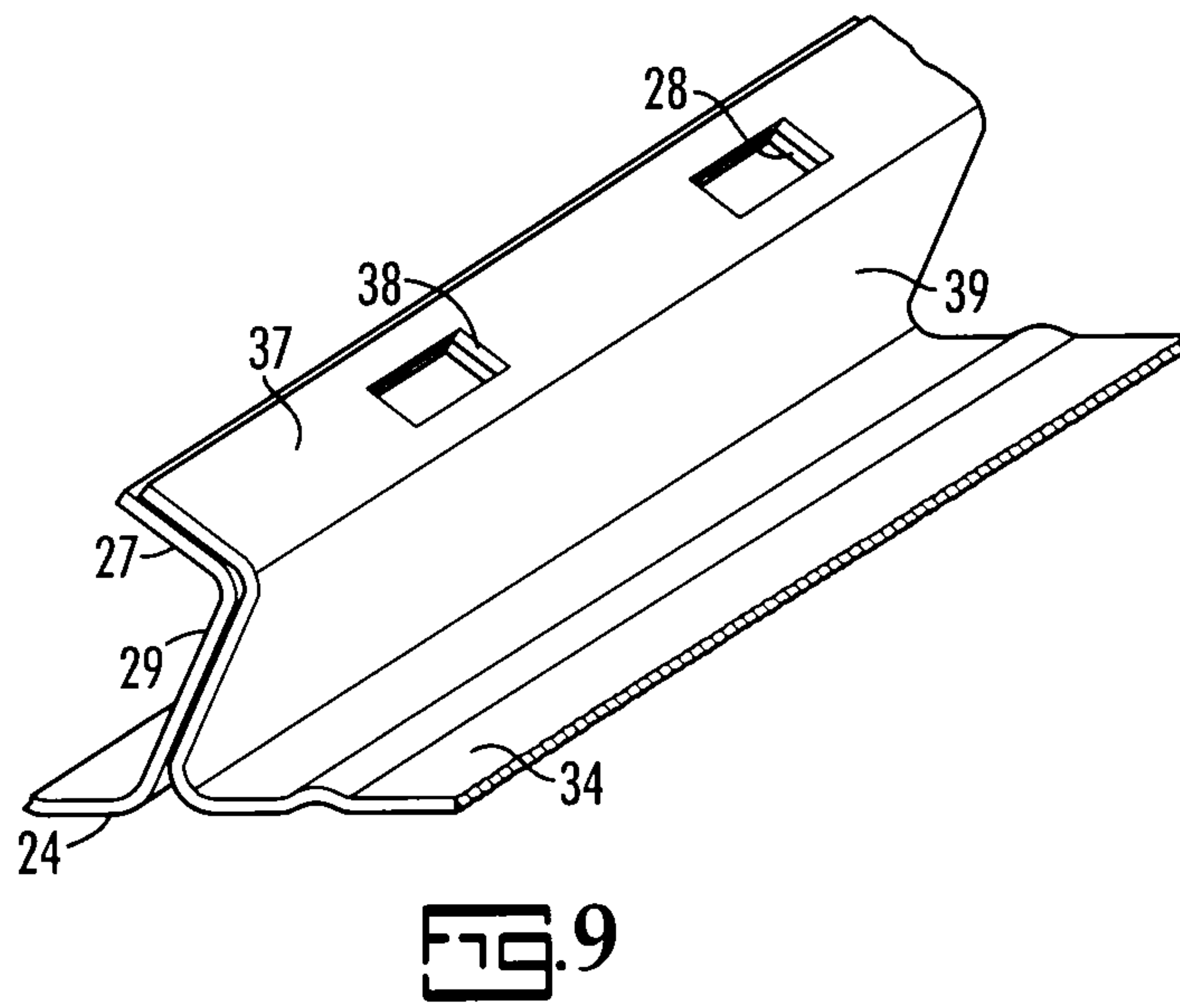
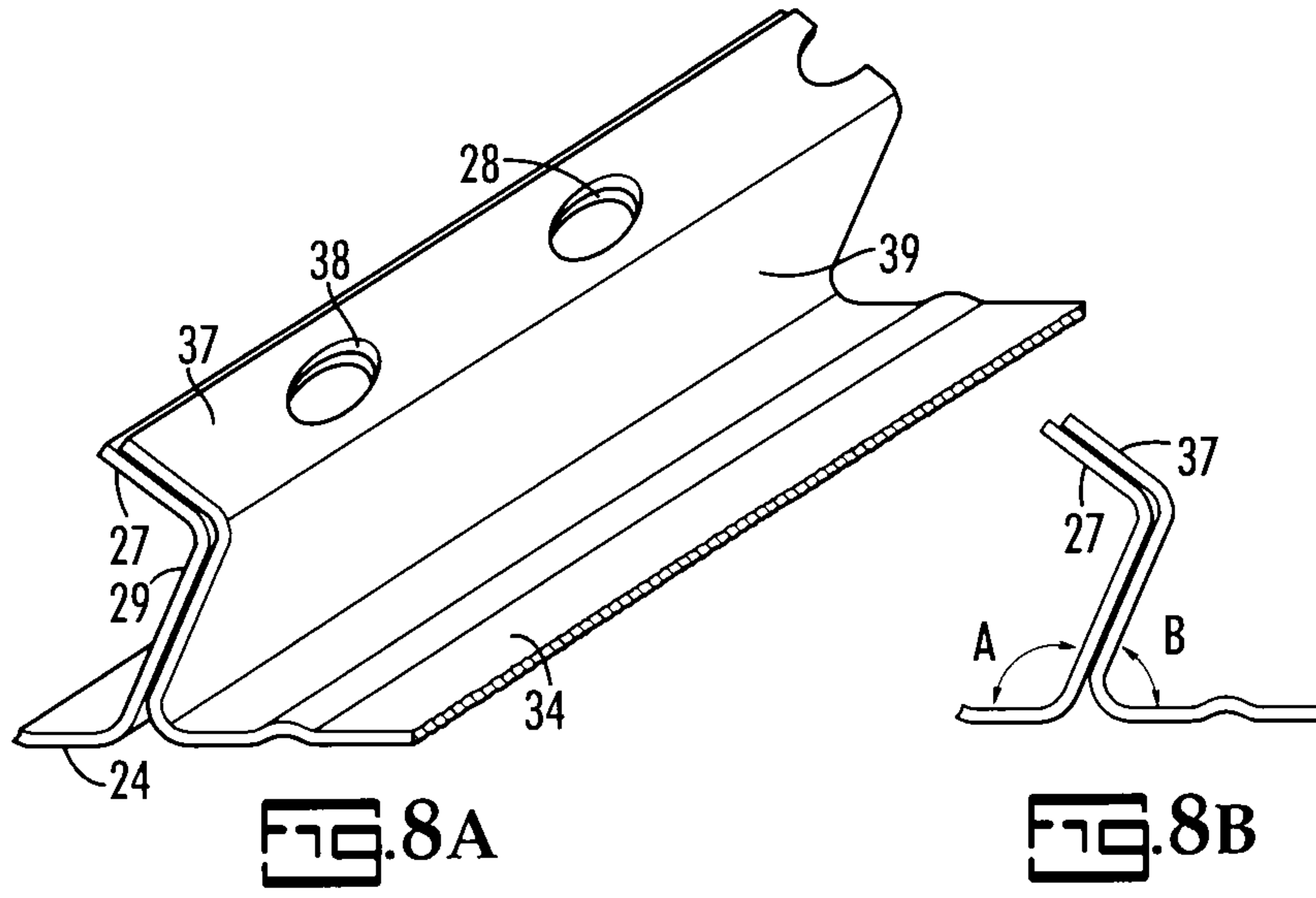
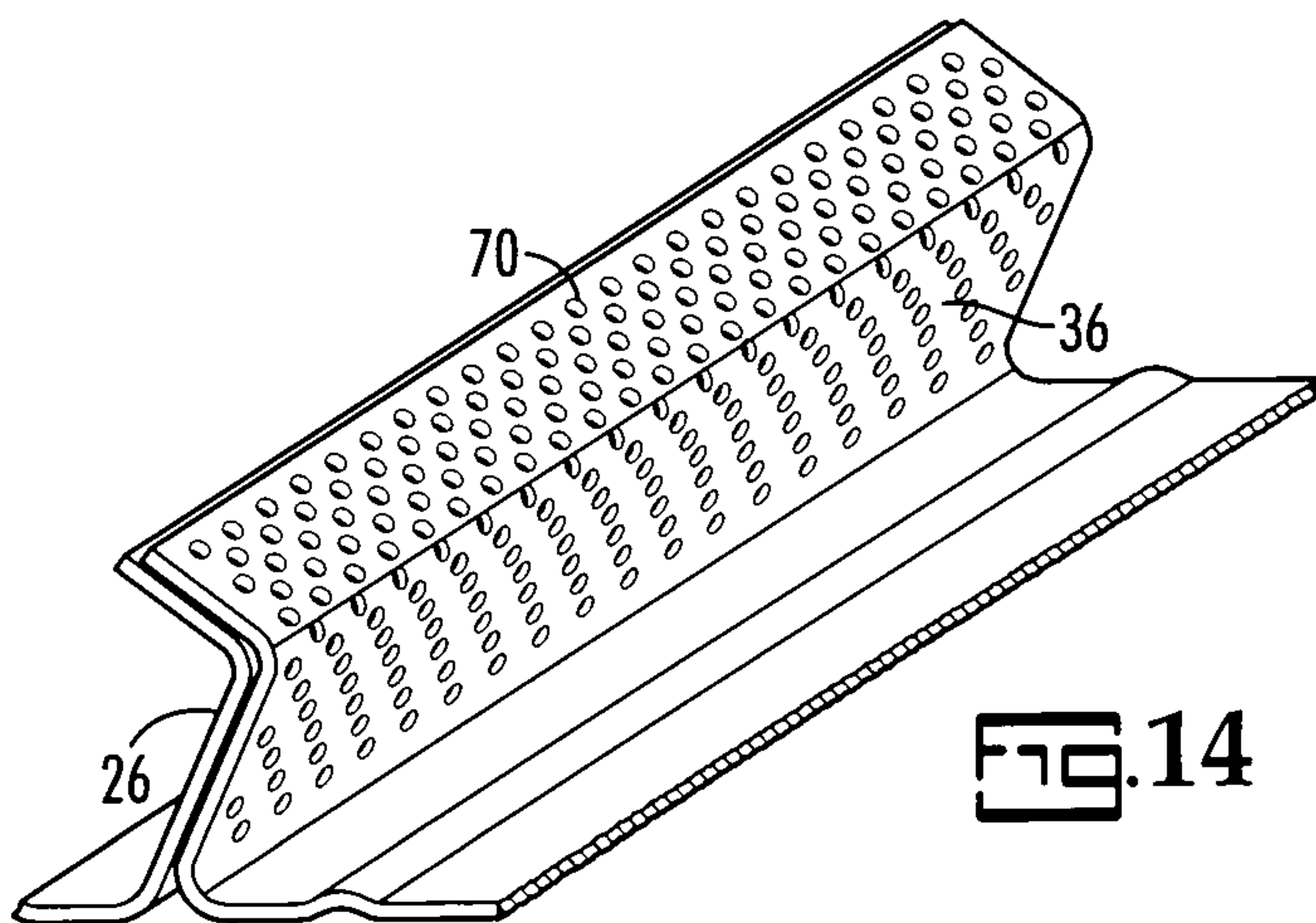
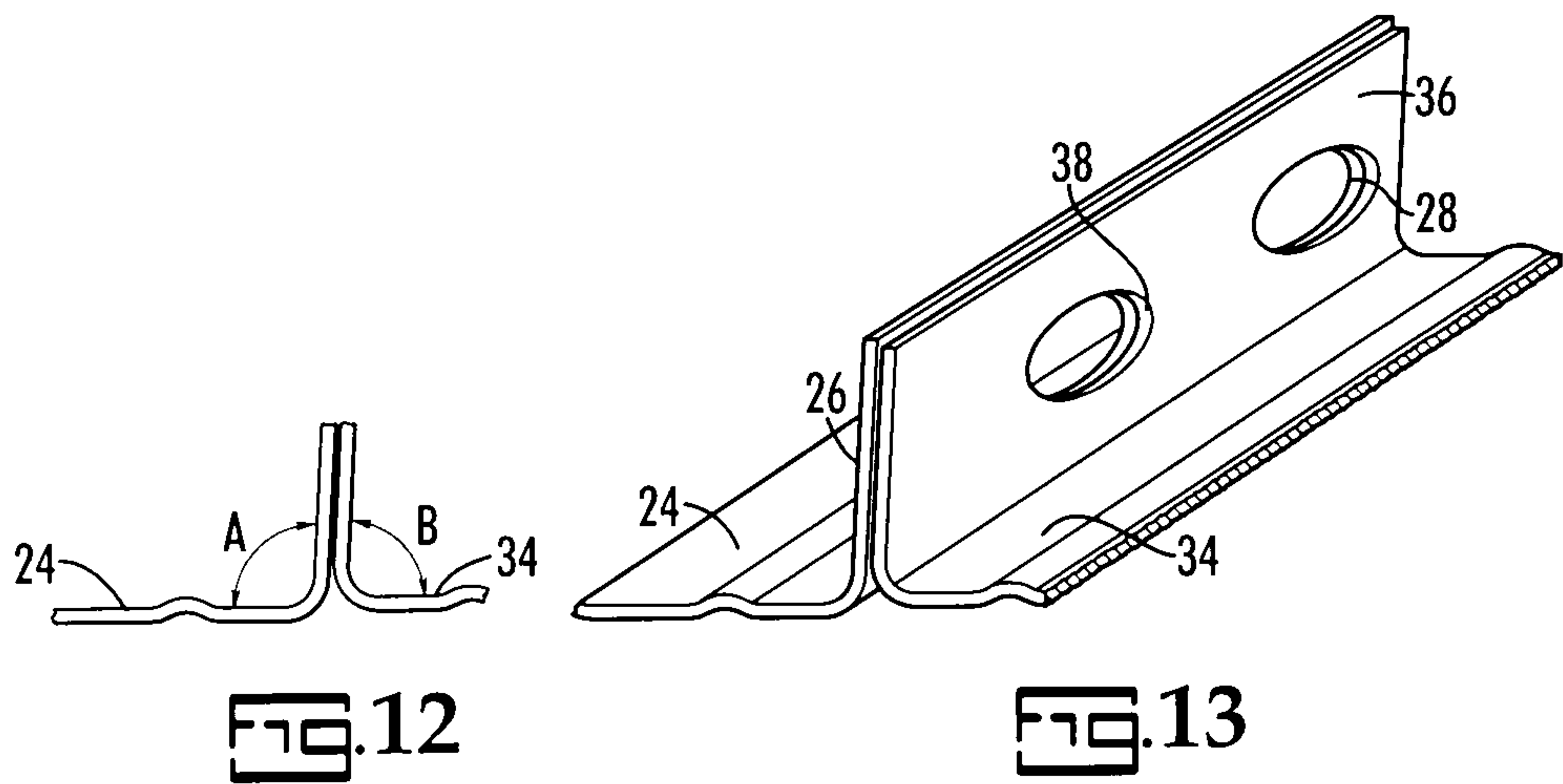
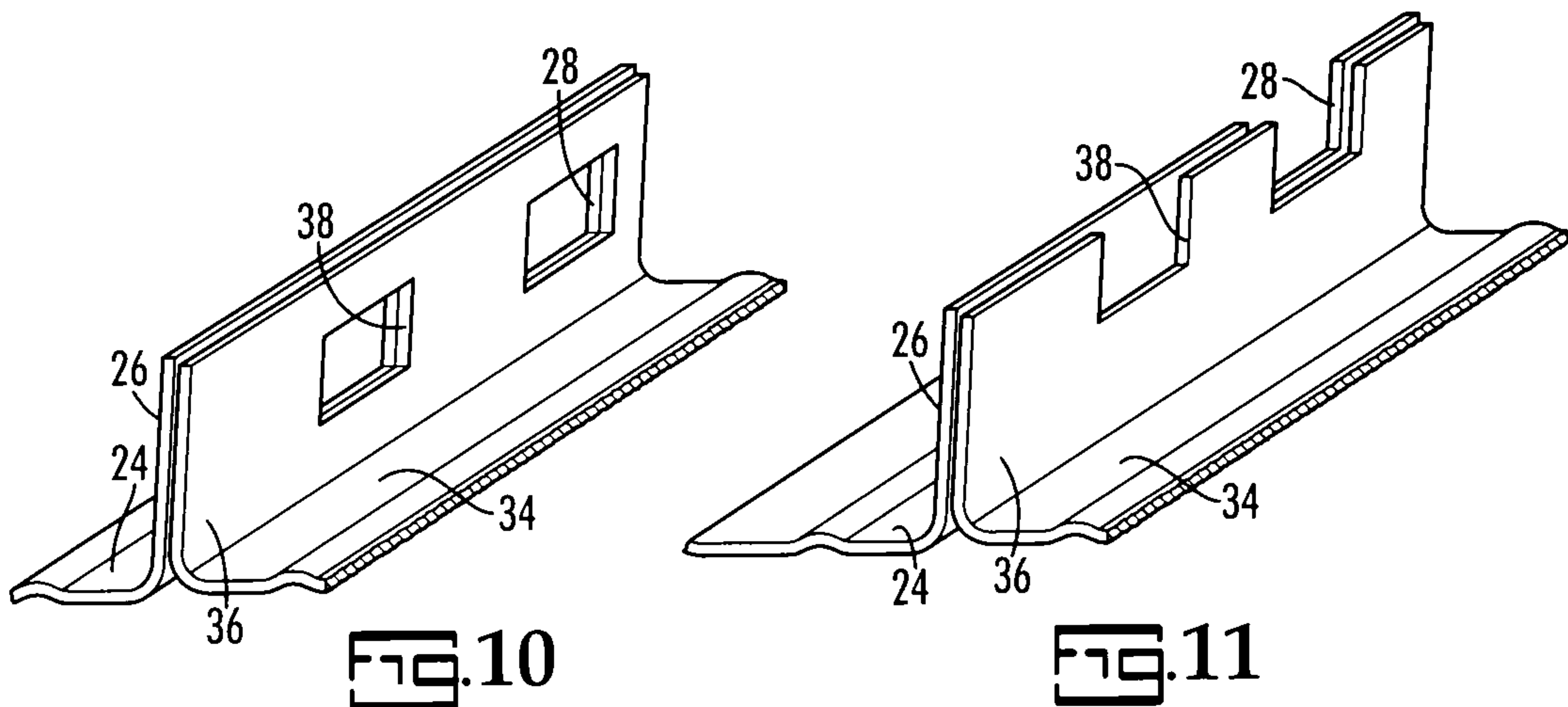
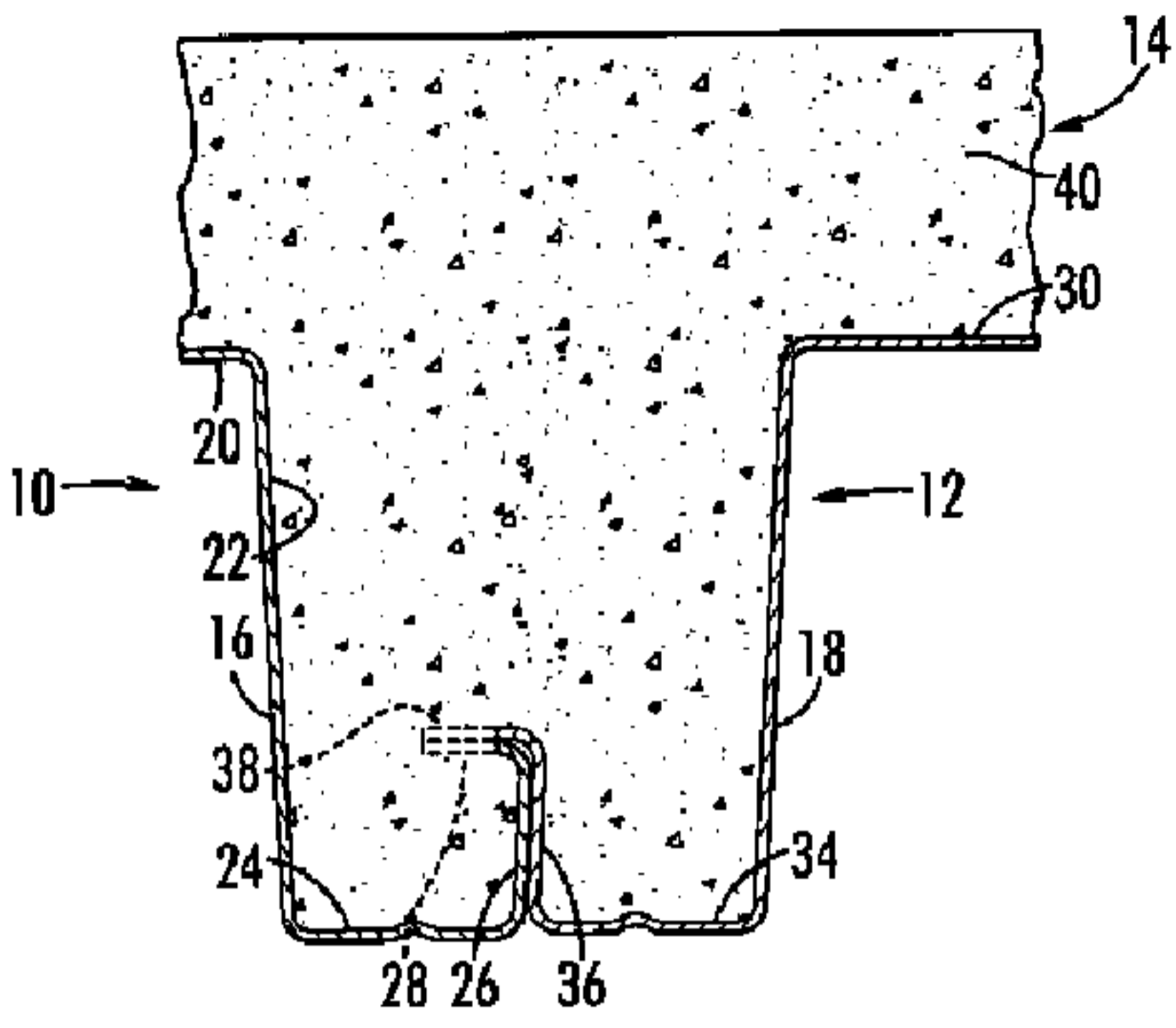

FIG. 7B







**A**

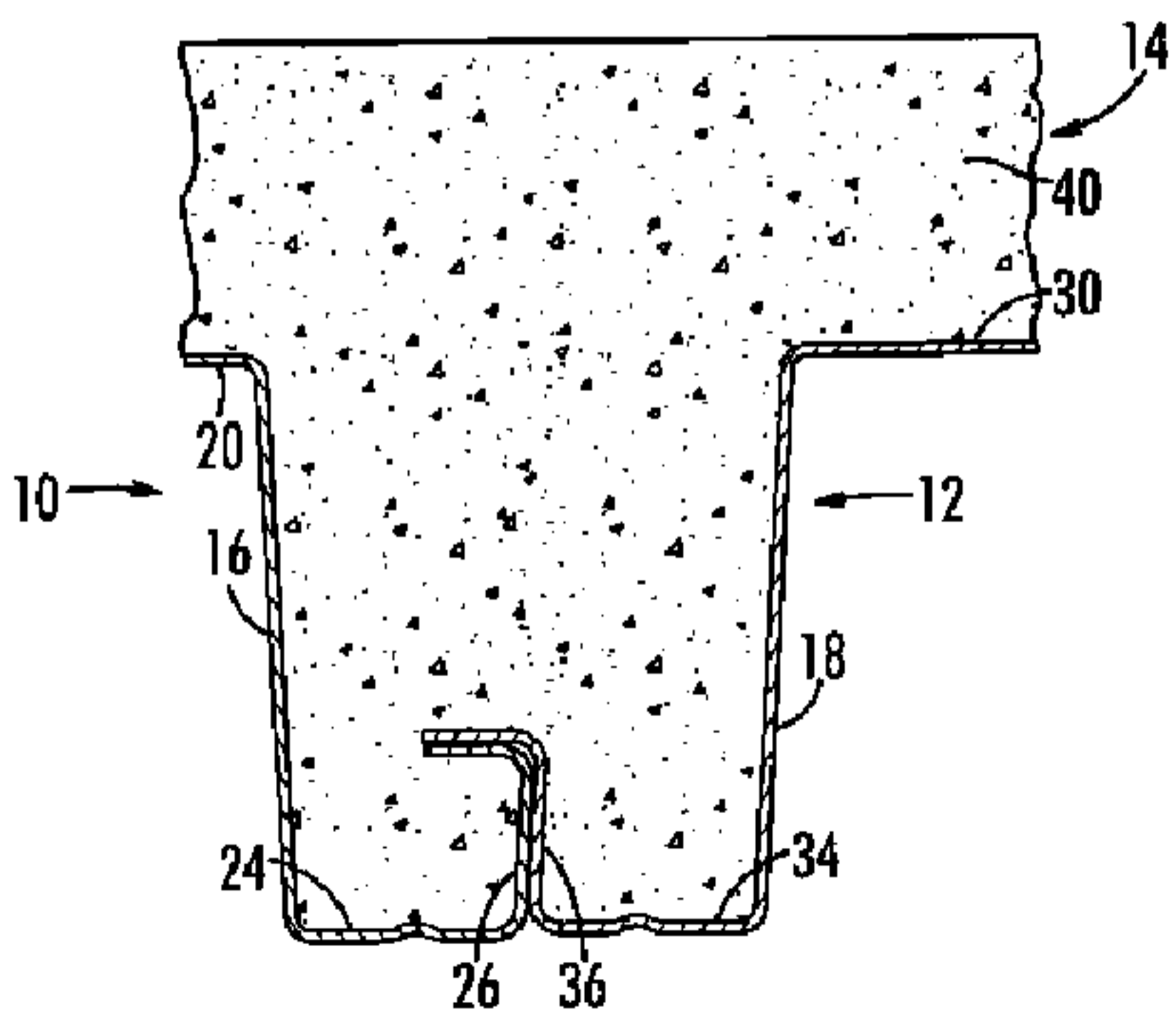

**B**